

---

# **Service Manual**

## **Flo-Gard® 6301**

---

### **Dual Channel Volumetric Infusion Pump**

**Product Code: 2M8064**

## Change Record Page

Specification number: 7-19-01-729

Original issue: 04/93

Rev A: 05/95

<b>Page</b>	<b>Revision</b>
Cover	A
(Back of cover blank)	
Title Page	A
Change Record Page	A
iii - viii	A
1-1 – 1-20	A
2-1 – 2-4	A
3-1 – 3-4	A
4-1 – 4-8	A
5-1 – 5-20	A
6-1 – 6-38	A
7-1 – 7-16	A
8-1 – 8-48	A
9-1 – 9-2	A
10-1 – 10-40	A
(Backs of 10-3 – 10-40 blank)	
A-1 – A-2	A
B-1	A
(Back of B1 blank)	
(Inside of Back cover blank)	
Back cover	A

A zero in the revision column indicates original issue.

# Table of Contents

<b>General Description</b>	<b>1-1</b>
1.1 Introduction	1-1
1.2 Device Overview	1-1
1.2.1 Principal Features	1-1
1.2.2 Nurse Call	1-2
1.3 Technical Specifications	1-3
1.4 Controls and Indicators	1-4
1.5 Configuration Option Feature	1-12
1.5.1 Reviewing the Configuration Option Settings	1-12
1.5.2 Modifying the Configuration Option Settings	1-13
1.6 Alarms	1-17
1.7 Alerts	1-19
<b>Hospital Service Procedures</b>	<b>2-1</b>
2.1 Replacement Of Main Power Fuse	2-1
2.2 Cleaning	2-1
2.3 Battery Charging	2-3
2.4 Preventive Maintenance	2-3
<b>Problem Checklist</b>	<b>3-1</b>
<b>Theory of Operation</b>	<b>4-1</b>
4.1 CPU System	4-1
4.1.1 CPUs	4-1
4.1.2 Programmable Timer Module (PTM)	4-2
4.1.3 Watchdog Function	4-2
4.1.4 I/O Controllers	4-3
4.1.5 Multiplexer	4-3
4.1.6 Universal Pulse Processor	4-3
4.1.7 Communication Controller	4-4
4.1.8 Air Sensor Circuit	4-4
4.1.9 Occlusion Sensors	4-4
4.1.10 Tube Misloading Detectors	4-5
4.1.11 Slide Clamp Detectors	4-5
4.1.12 Battery Low Alert/Alarm Detector	4-5
4.1.13 Interlock Switches	4-5
4.1.14 Panel Lock Circuit	4-6
4.1.15 Keypad	4-6
4.1.16 Displays	4-6
4.1.17 Motor Driver	4-6

4.1.18 Motor Rotation Detectors . . . . .	4-7
4.2 DC Power Supply and Power Control Circuit . . . . .	4-7
<b>Troubleshooting . . . . .</b>	<b>5-1</b>
5.1 Introduction . . . . .	5-1
5.2 Failure Identification Codes . . . . .	5-1
5.3 Automatic Test Modes . . . . .	5-2
5.3.1 Automatic Test Mode 1: Calibration Mode 1 . . . . .	5-2
5.3.2 Automatic Test Mode 2: Calibration Mode 2 . . . . .	5-4
5.3.3 Automatic Test Mode 3: Manufacturing Test Mode . . . . .	5-5
5.3.4 Automatic Test Mode 4: Aging Mode . . . . .	5-5
5.3.5 Automatic Test Mode 5: Display Check Mode . . . . .	5-6
5.3.6 Automatic Test Mode 6: Time Information Display Mode . . . . .	5-6
5.3.7 Automatic Test Mode 7: Pumping Sensor Monitoring Mode . . . . .	5-6
5.3.8 Automatic Test Mode 8: Air Sensor Test Mode . . . . .	5-6
5.3.9 Automatic Test Mode 9: Elapsed Time Test Mode . . . . .	5-7
5.3.10 Automatic Test Mode 0: Downstream Occlusion Test Mode . . . . .	5-7
5.4 Failure Identification Code Troubleshooting Table . . . . .	5-8
5.5 Troubleshooting Chart . . . . .	5-16
<b>Disassembly and Calibration . . . . .</b>	<b>6-1</b>
6.1 Introduction . . . . .	6-1
6.2 Preparation for Maintenance . . . . .	6-1
6.2.1 Tools and Test Equipment . . . . .	6-1
6.2.2 Recording the Configuration Option Settings . . . . .	6-2
6.3 Disassembly/Reassembly . . . . .	6-3
6.3.1 Separation of Front and Rear Housings . . . . .	6-3
6.3.2 Separation of Printed Circuit Boards . . . . .	6-5
6.3.3 Replacement of Front Panel Film . . . . .	6-7
6.3.4 Replacement of Pump Door Cover . . . . .	6-7
6.3.5 Replacement of Pump Door Latch . . . . .	6-8
6.3.6 Replacement of Pump Door or Pump Door Assembly . . . . .	6-8
6.3.7 Replacement of Door Latch Pin . . . . .	6-9
6.3.8 Replacement of Pump Head Assembly . . . . .	6-9
6.3.9 Replacement of Upstream Occlusion Sensor . . . . .	6-10
6.3.10 Replacement of Downstream Occlusion Sensor Assembly . . . . .	6-11
6.3.11 Installation of Air Sensor Assembly . . . . .	6-11
6.3.12 Replacement of Force Sensing Resistor* ( <i>FSR</i> **)	
Devices for Tube Misloading Sensors . . . . .	6-12
6.3.13 Replacement of Pump Motor . . . . .	6-14
6.3.14 Replacement of Safety/Slide Clamp Assembly . . . . .	6-16
6.3.15 Spring Retainer Removal . . . . .	6-17
6.3.16 Spring Retainer Installation . . . . .	6-18
6.3.17 Replacement of Back Plate . . . . .	6-18
6.3.18 Replacement of Battery . . . . .	6-19

\* Interlink Electronics  
\*\*Interlink Electronics



6.3.19 Replacement of Power Supply Board . . . . .	6-20
6.3.20 Replacement of CPU/Display Board . . . . .	6-21
6.3.21 Replacement of Audible Alarm/Alert Board . . . . .	6-21
6.3.22 Replacement of Backup Audible Alarm/Alert Board . . . . .	6-22
6.3.23 Replacement of Terminal Board . . . . .	6-22
6.3.24 Replacement of Power Transformer . . . . .	6-22
6.3.25 Replacement of the PANEL LOCK Switch . . . . .	6-23
6.3.26 Replacement of Lithium Backup Battery . . . . .	6-24
6.3.27 Tube Guide Shim Installation . . . . .	6-24
6.3.28 LCD Cushion Installation . . . . .	6-26
6.3.29 Software Installation . . . . .	6-27
<b>6.4 Calibration . . . . .</b>	<b>6-29</b>
6.4.1 DC Line Voltages . . . . .	6-29
6.4.2 Air Sensor Calibration . . . . .	6-32
6.4.3 Downstream Occlusion Sensor Calibration . . . . .	6-34
6.4.4 Upstream Occlusion Sensor Calibration . . . . .	6-35
6.4.5 Slide Clamp Sensor Calibration . . . . .	6-36
6.4.6 Slide Shaft Sensor Calibration . . . . .	6-37
6.4.7 A/D Convertor Reference Voltage Calibration . . . . .	6-38
<b>Checkout . . . . .</b>	<b>7-1</b>
7.1 Introduction . . . . .	7-1
7.2 Maintenance Flowchart . . . . .	7-1
7.3 Operational Checkout . . . . .	7-3
7.3.1 Administration Set Placement . . . . .	7-3
7.3.2 Functional Testing . . . . .	7-3
7.3.3 Door Open Alarm Testing . . . . .	7-5
7.3.4 Air Alarm Testing . . . . .	7-6
7.3.5 Drive Defect Test/Occlusion Check . . . . .	7-7
7.3.6 Downstream Occlusion Testing . . . . .	7-7
7.3.7 Upstream Occlusion Testing . . . . .	7-8
7.3.8 Battery Check . . . . .	7-9
7.3.9 Panel Lock Test . . . . .	7-10
7.3.10 Safety Clamp Test . . . . .	7-10
7.3.11 Alarm Volume . . . . .	7-11
7.3.12 Slide Clamp Test . . . . .	7-11
7.3.13 Electrical Safety Tests . . . . .	7-12
7.3.14 Accuracy Tests . . . . .	7-13
<b>Illustrated Parts Breakdown . . . . .</b>	<b>8-1</b>
<b>Warranty and Service Information . . . . .</b>	<b>9-1</b>
9.1 Warranty Information . . . . .	9-1
9.2 Service Information . . . . .	9-1
9.3 General Information . . . . .	9-2

**Diagrams . . . . . 10-1**  
**Data Sheet, Flo-Gard® 6301**  
**Volumetric Infusion Pump (2M8064) . . . . . A-1**  
**Multiple Key Combinations . . . . . B-1**

# List of Illustrations

Figure 1-1. Front View of Pump . . . . .	1-5
Figure 1-2. Pump with Door Open . . . . .	1-8
Figure 1-3. Rear View of Pump . . . . .	1-10
Figure 6-1. Adhesive Application . . . . .	6-25
Figure 6-2. Pressure Application Points . . . . .	6-25
Figure 6-3. LCD Cushion Placement . . . . .	6-27
Figure 6-4. Calibration Equipment Setup . . . . .	6-30
Figure 7-1. Maintenance Flowchart . . . . .	7-2
Figure 8-1. Front Housing Assembly - External . . . . .	8-3
Figure 8-2. Front Housing Assembly - Internal . . . . .	8-5
Figure 8-3. Rear Housing Assembly - Internal . . . . .	8-7
Figure 8-4. Rear Housing Assembly - External . . . . .	8-9
Figure 8-5. Pump Head Door Assembly . . . . .	8-13
Figure 8-6. Pump 1 Base Plate Assembly with FSRs . . . . .	8-15
Figure 8-7. Pump 1 Base Plate Assembly-Rear . . . . .	8-17
Figure 8-8. Pump 1 Base Plate Assembly with Pump Mechanism . . . . .	8-19
Figure 8-9. Safety/Slide Clamp Assembly 1 . . . . .	8-23
Figure 8-10. Pump Head 2 Door Assembly . . . . .	8-25
Figure 8-11. Pump 2 Base Plate Assembly with FSRs . . . . .	8-27
Figure 8-12. Pump 2 Base Plate Assembly - Rear . . . . .	8-29
Figure 8-13. Pump 2 Base Plate Assembly with Pump Mechanism . . . . .	8-31
Figure 8-14. Safety/Slide Clamp Assembly 2 . . . . .	8-35
Figure 8-15. Power Supply Board Component and Solder Sides . . . . .	8-37
Figure 8-16. Display PCB - Component Side . . . . .	8-39
Figure 8-16. Display PCB - Solder Side . . . . .	8-40
Figure 8-17. CPU PCB - Component Side . . . . .	8-42
Figure 8-17. CPU PCB - Solder Side . . . . .	8-43
Figure 8-18. Terminal PCB . . . . .	8-44
Figure 8-19. Backup Buzzer Board . . . . .	8-45
Figure 8-20. Audible Alarm PCB . . . . .	8-46
Figure 10-1. System Block Diagram . . . . .	10-3
Figure 10-2. Rear Housing Wiring Diagram . . . . .	10-4
Figure 10-3. Front Housing Wiring Diagram . . . . .	10-5
Figure 10-4. CPU Board Block Diagram . . . . .	10-6
Figure 10-5. Power Supply Section . . . . .	10-7
Figure 10-6. DC Power Supply . . . . .	10-8
Figure 10-7. Power Supply Control . . . . .	10-9
Figure 10-8. Power Supply Control - Hybrid Circuit . . . . .	10-10
Figure 10-9. Master CPU Block Diagram . . . . .	10-11

Figure 10-10. Master CPU Schematic . . . . .	10-12
Figure 10-11. UPP, RTC and SRAM Block (P/O CPU Board) . . . . .	10-13
Figure 10-12. Alarm Control Circuit . . . . .	10-14
Figure 10-13. Address Decoder . . . . .	10-15
Figure 10-14. Serial Communication Block . . . . .	10-16
Figure 10-15. Slave CPU Block Diagram . . . . .	10-17
Figure 10-16. Slave CPU Schematic . . . . .	10-18
Figure 10-17. Slave RAM and Programmable Timer Module (PTM) . . . . .	10-19
Figure 10-18. Motor Driver Circuit - Pump 1 . . . . .	10-20
Figure 10-19. Motor Driver Circuit - Pump 2 . . . . .	10-21
Figure 10-20. CPU PCB (Sensor Block) . . . . .	10-22
Figure 10-21. PPI Block #1 . . . . .	10-23
Figure 10-22. PPI Block #2 . . . . .	10-24
Figure 10-23. Occlusion Sensing Block . . . . .	10-25
Figure 10-24. Air Sensing Block . . . . .	10-26
Figure 10-25. Misload and Slide Clamp Sensors . . . . .	10-27
Figure 10-26. Display PCB . . . . .	10-28
Figure 10-27. LCD Drivers for Pump 1 . . . . .	10-29
Figure 10-28. LCD Drivers for Pump 2 . . . . .	10-30
Figure 10-29. LCDs for Pump 1 . . . . .	10-31
Figure 10-30. LCDs for Pump 2 . . . . .	10-32
Figure 10-31. LED Lamps . . . . .	10-33
Figure 10-32. Audible Alarm PCB . . . . .	10-34
Figure 10-33. Backup Buzzer PCB . . . . .	10-35
Figure 10-34. Terminal PCB . . . . .	10-36
Figure 10-35. Accessories . . . . .	10-37
Figure 10-36. Sensors on Pumphead 1 . . . . .	10-38
Figure 10-37. Sensors on Pumphead 2 . . . . .	10-39
Figure 10-38. Front Panel Key Assignments . . . . .	10-40

# Section 1

---

## General Description

### 1.1 Introduction

This manual provides service information for the Flo-Gard® 6301 Dual Channel Volumetric Infusion Pump (product code 2M8064) for qualified hospital biomedical engineers and Product Service personnel. See the device's Operator's Manual for detailed operating instructions.

### 1.2 Device Overview

#### 1.2.1 Principal Features

The Flo-Gard® 6301 Dual Channel Volumetric Infusion Pump is an electromechanical device used for the intravenous infusion of liquids at user-selected rates. The device contains two linear peristaltic pump heads, allowing it to simultaneously infuse two different solutions. Each pump head is independently programmable and permits infusion of primary and secondary medication programs. The secondary program automatically switches over to the primary program when secondary infusion is complete (automatic piggybacking).

The device operates on standard 115 VAC 60 Hz electrical power, or on its self-contained rechargeable battery. It is portable and has a panel lock-out feature to prevent patient tampering. It is designed for use with Baxter's standard administration sets which contain an "s" as the last character of the code number, for example, 2C5537s. When infusing solutions through a central line catheter, sets with Luer lock adapter should be used. Sets with a Flashball® device are not recommended in these applications.

The primary rate of infusion is selectable from 1 to 1,999 mL in 1 mL/hr increments and 1.0 to 99.9 mL/hr in 0.1 mL/hr increments. The secondary rate is selectable from 1 to 999 mL in 1 mL/hr increments and 1.0 to 99.9 mL/hr in 0.1 mL/hr increments. The volume to be infused (VTBI) is also selectable from 1 to 9,999 mL in 1 mL increments and 1.0 to 99.9 mL in 0.1 mL increments.

The total volumes infused from primary and secondary programs are added together and accumulated and can be displayed on demand. The primary and secondary VTBI are independently decremented and displayed. Upon completion of the primary VTBI, the pump automatically switches to a keep vein open (KVO) rate. If the pump is started on a secondary rate and VTBI, the pump will change to the primary rate when the secondary program is completed. Either pump may be stopped at any time by depressing the STOP key unless the device is in the lock-out mode.

### 1.2.2 Nurse Call

The Nurse Call feature is enabled by installing a jumper wire to the Terminal Printed Circuit Board at the location labeled R421 on the board. When the jumper is connected, the Nurse Call relay will be energized only during an alarm condition and when the ALARM LED is lit. The relay contact points (normally closed, normally open, and common) are accessible from the COMMUNICATIONS PORT on the rear of the device (pins 1, 4, and 9, respectively). The Nurse Call feature may be used when the device is connected to a computer, however, provisions must be made at the communications port to connect both options simultaneously. Specifications for the 9-pin D connector are listed under Technical Specifications.

### 1.3 Technical Specifications

Item	Characteristic
Catalog Code Number	2M8064
Description	Dual channel linear peristaltic volumetric infusion pump
Administration Set	Baxter's standard administration set with "s" suffix
Keep Vein Open (KVO) rate	5 mL/hr or programmed rate, whichever is less
Battery	12 Volt, 3.2 Ah sealed lead acid
Battery Life	- Approximately 6 hours with one pump running at a rate from 1 to 1400 mL/hr using a fully charged battery - Approximately 4 hours with both pumps running at a rate from 1 to 1400 mL/hr using a fully charged battery
Battery Recharge	8 hours for 80% recharge
AC Power Requirements	110/120V, 60 Hz
Power Cord	2.75 m (9.0 ft.) long, with Hospital Grade plug
Leakage Current	Typically less than 50 microamps (using UL-544 specified test methods)
Power Consumption	50 watts
Weight	8.2 kg (18 lbs)
Dimensions	33 cm W x 13 cm D x 29 cm H (13" W x 5.1" D x 11.4" H)
Flow Rate Range	Primary program: 1 - 1,999 mL/hr in 1 mL/hr increments and 1.0 - 99.9 mL/hr in 0.1 mL/hr increments. Upper limit can be reduced by authorized service personnel. Secondary program: 1 - 999 mL/hr in 1 mL/hr increments and 1.0 - 99.9 mL/hr in 0.1 mL/hr increments.
VTBI Range	1 - 9,999 mL in 1 mL increments and 1.0 - 99.9 in 0.1 mL increments for both primary and secondary. Upper limit can be reduced by authorized service personnel.
Air-in-Line Detection	Factory set to NORM which causes the device to alarm on air bubbles approximately 75 $\mu$ L or larger. The MIN setting causes the device to alarm on bubbles approximately 50 $\mu$ L or larger.
Fuse	0.5 A Slo-Blo
Nurse Call	9-pin D connector, Pin 1: N/C (normally closed), Pin 4: N/O (normally open), Pin 9: Common Contact rating: 0.4A at 30 VAC, 2A at 30 VDC resistive load (internal connection required)

## 1.4 Controls and Indicators

All controls and indicators are shown in Figures 1-1, 1-2, and 1-3. Service personnel should be familiar with the pump's features and operation before servicing the device. Items 1 through 9 in Figure 1-1 are associated with Pump 1. The controls associated with Pump 2 are identical and function in exactly the same manner. Items 10 through 27, Figure 1-1 are common to the operation of both pumps. When the word "device" is used in this manual, reference is being made to the entire Flo-Gard® 6301 Dual Channel Volumetric Infusion Pump. Generally, the word "pump" is used to refer to either Pump 1 or Pump 2.

Each device's serial number is recorded on a label on the back of the device.

ITEM	FUNCTION
1. Pump 1 ON-OFF/CHARGE Key	Turns Pump 1 on and off. The internal battery charger remains on regardless of the ON-OFF/CHARGE key as long as the device is plugged in.
2. Pump 1 Door Latch	Opens and closes pump door.
3. Pump 1 STOP Key	Stops Pump 1. The message <b>STOPPED</b> appears when the key is pressed. An alert will sound if Pump 1 is stopped for more than two minutes. Clears all programming alerts while pump is running.
4. PUMP 1 Key and Indicator	Allows the device to accept keystrokes and other controls common to both pumps for Pump 1 programming. Yellow LED lights to indicate that Pump 1 is selected.
5. Pump 1 Main Display	Shows rate, volume to be infused (VTBI) and total volume infused for Pump 1 primary and secondary infusion programs.
6. Pump 1 Message Display	Shows all Pump 1 messages.
7. Pump 1 ALARM LED	Red LED that blinks on and off during a Pump 1 alarm, accompanied by a visual message display and a repeated sequence of three beeps. An alarm indicates that Pump 1 requires immediate attention.
8. Pump 1 PUMPING LED	Green LED which is constantly lit while Pump 1 is pumping.



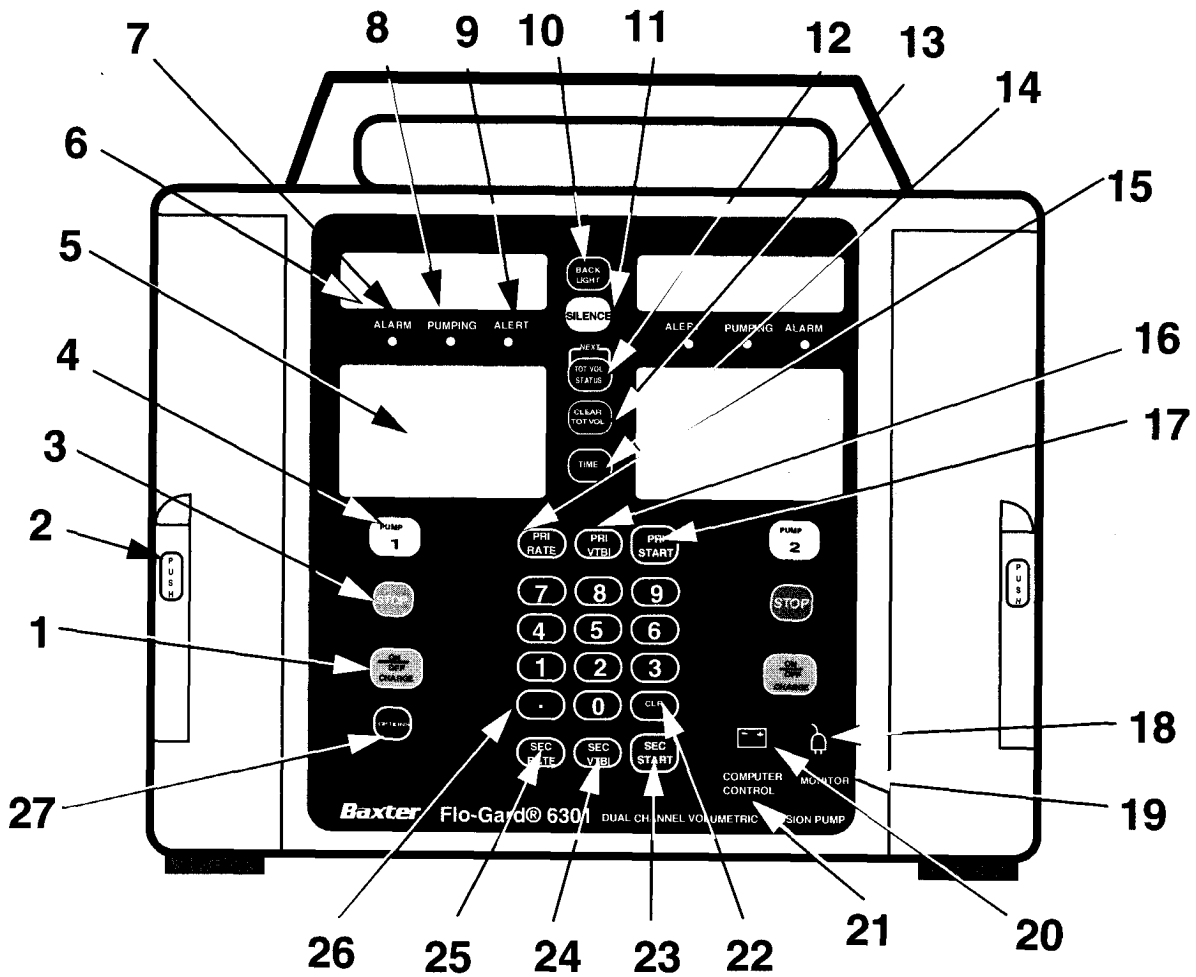

Figure 1-1. Front View

- |                        |  |
|------------------------|--|
| 9. Pump 1 ALERT LED    | Yellow LED which lights during Pump 1 alerts, accompanied by a message display and a repeated single beep. An alert indicates that Pump 1 needs routine attention.   |
| 10. BACKLIGHT key      | Provides backlighting of the displays when the device is used in darkened areas. The key toggles the backlighting on and off. If the device is operating on battery power, the backlight remains on for 60 seconds and turns off automatically to conserve battery power.  |
| 11. SILENCE Key        | Temporarily silences an audible alarm or alert for two minutes. All visual alarm or alert information remains displayed.   |
| 12. TOT VOL/STATUS Key | Dual-function key. During operation, this key causes total volume delivered and current settings to display when pressed. It is also used to select a next step in Review Configuration, Modify Configuration and Programmed Delivery Profile modes. The word "NEXT" above the key is illuminated when the key is functioning as a NEXT key. |
| 13. CLEAR TOT VOL Key  | Resets the total volume delivered to zero when the pump is stopped.  |
| 14. TIME Key           | Enters desired time interval for an infusion during Volume-Time or Rate-Time programming.  |
| 15. PRI RATE Key       | Allows programming of the primary infusion rate.   |
| 16. PRI VTBI Key       | Allows programming of the primary VTBI.  |
| 17. PRI START Key      | Starts the primary infusion.   |
| 18. PLUG Icon          | Green LED, always lit while the device is plugged in and the battery is charging.  |
| 19. MONITOR Legend     | Yellow LED which lights for at least 2 seconds each time the host computer communicates with the device when the device is in monitor mode.  |
| 20. BATTERY Icon       | Yellow LED, always lit while the device is operating on battery power.   |

- |                             |  |
|-----------------------------|--|
| 21. COMPUTER CONTROL Legend | Yellow LED which flashes when the device is initiating communications with a host computer to enter the computer control mode. It is constantly illuminated when the device is in computer control mode. |
| 22. CLR Key                 | Clears any locked in values and programming values currently being entered.  |
| 23. SEC START Key           | Starts the delivery of the secondary solution.   |
| 24. SEC VTBI Key            | Allows programming of the secondary VTBI.  |
| 25. SEC RATE Key            | Allows programming of the secondary infusion rate.   |
| 26. Numerical Keyboard      | The numerical values for rate, VTBI and time are entered with these keys.  |
| 27. OPTIONS Key/Legend      | Enables the device to operate in special modes.  |

See Figure 1-2 for the location of the following items. Note that this figure shows Pump 2 only. Pump 1 has identical features which function in the same manner.

- 1. Upstream Occlusion Sensor      Detects a complete tubing restriction upstream of the pump.
- 2. Pump Mechanism                Linear peristaltic pump mechanism.
- 3. Tube Misloading Sensor      Detects misloaded tubing out of the channel guide slot.

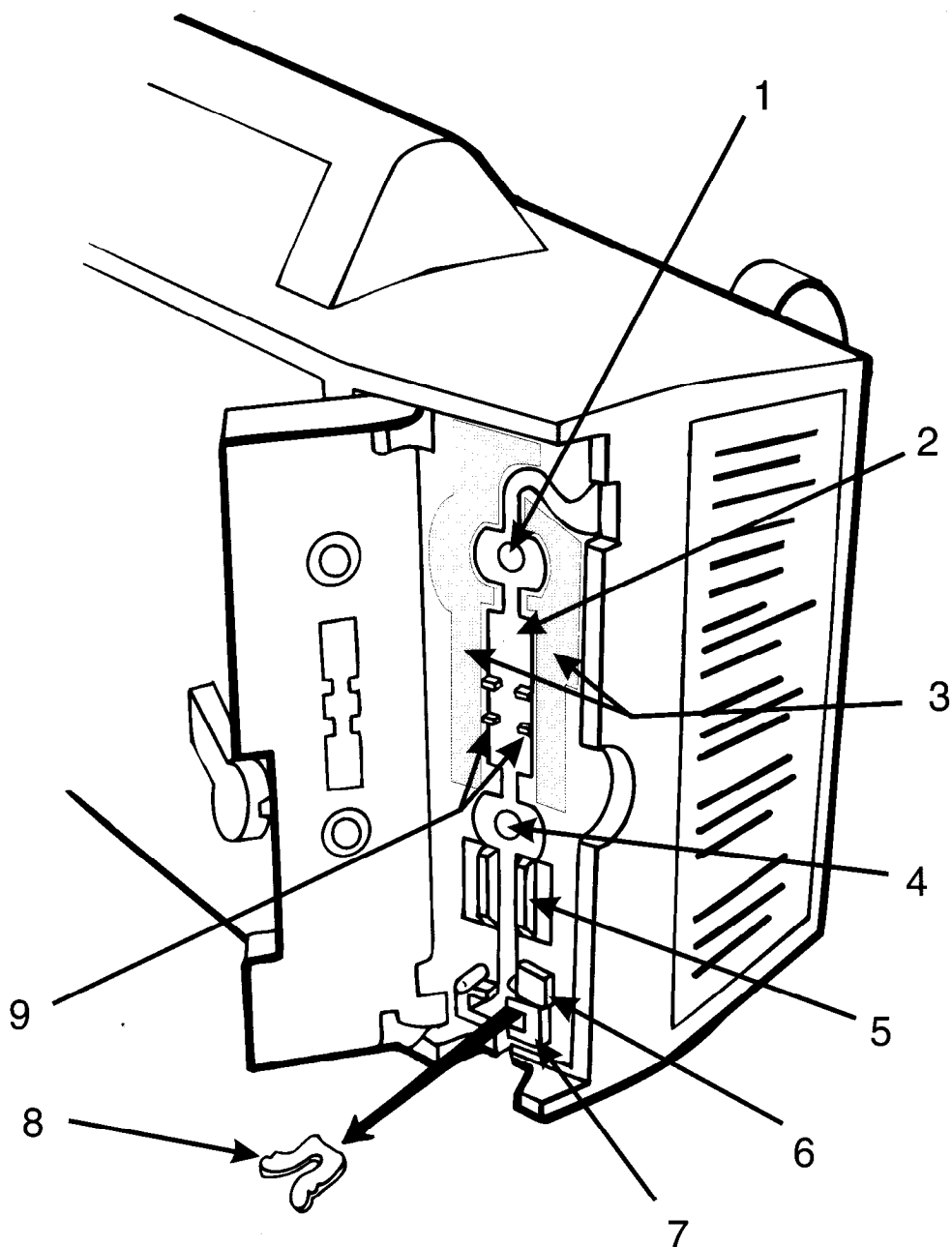

*Figure 1-2. Pump With Door Open*

- 
- |                                |  |
|--------------------------------|--|
| 4. Downstream Occlusion Sensor | Detects complete tubing restrictions downstream of the pump.   |
| 5. Air Sensor                  | Detects air bubbles in the IV set.   |
| 6. Safety Clamp                | Prevents accidental fluid flow when the IV set is properly loaded and the pump door is opened.   |
| 7. Slide Clamp Feature         | Provides an additional means of preventing accidental gravity fluid flow by occluding the tubing in the administration set with the slide clamp before the set can be removed from the pump. The use of this feature is optional; when used, the slide clamp must be loaded in the slide clamp slot. The feature is selectable through the pump's configuration options. If alert mode is enabled, the pump will operate without the slide clamp inserted and the <b>INSERT SLIDE CLAMP</b> message displayed. An alert tone will sound to notify the user that the slide clamp should be inserted. If the alarm mode is enabled (software versions 1.09 or later), the pump will NOT start and an alarm tone will sound if the slide clamp is not loaded. |
| 8. Spring Retainer Insert      | The pump is shipped from the factory with this plastic insert in the slide clamp slot. It prevents damage to the mechanism during shipment and maintains the proper spring tension. If your hospital does not plan on using the slide clamp feature, Baxter recommends that this plastic insert remain in place during use. See Section 6.3.16.  |
| 9. Channel Guide Ridges        | Function as a guide to keep the tubing properly aligned over the pumping fingers.  |

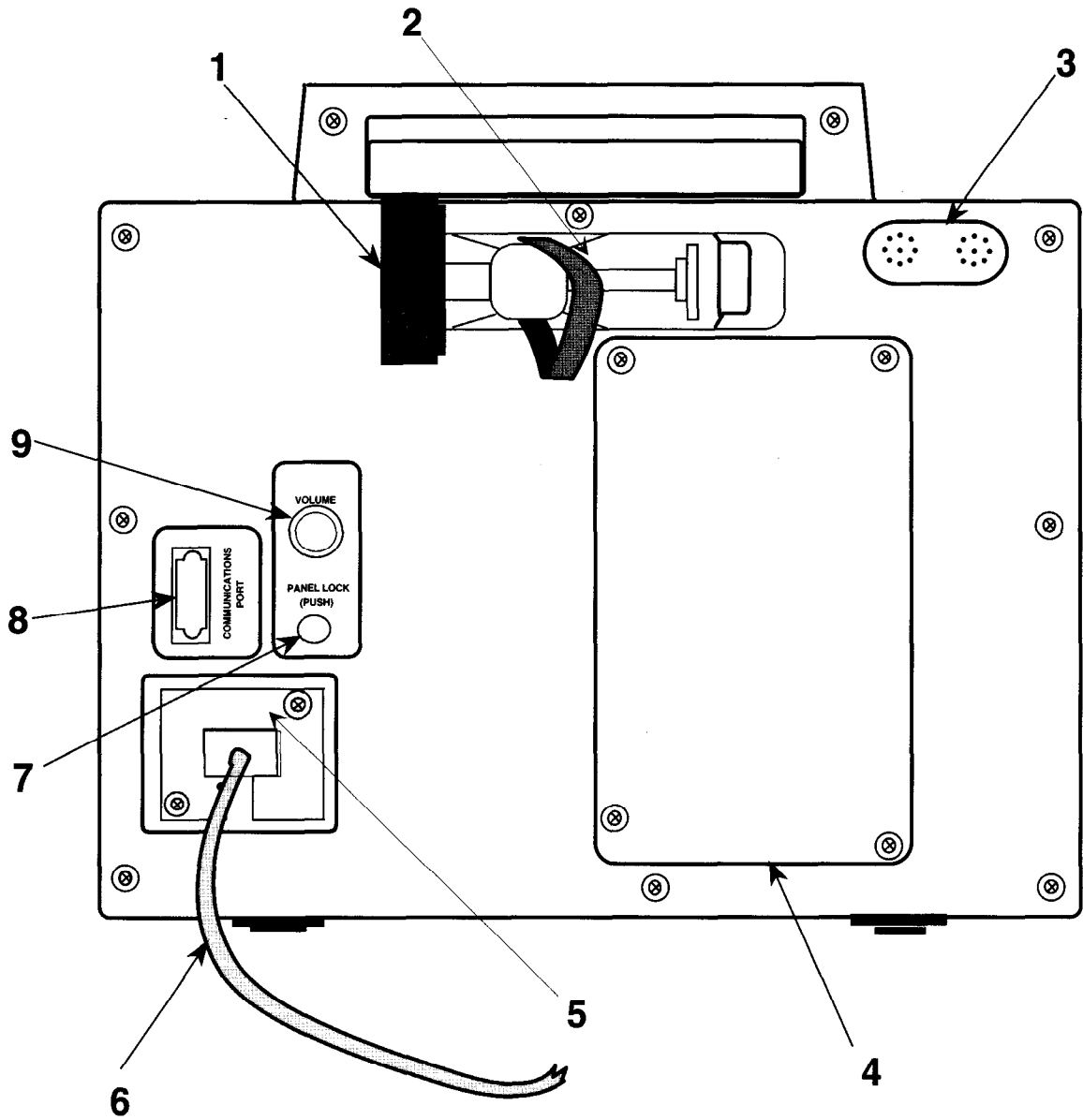

Figure 1-3. Rear View

The following items are located on the rear of the device and are shown in Figure 1-3.

1. IV Pole Clamp                                  Secures the device to the IV pole.
  
2. Power Cord Strap                              Stores power cord during battery operation and device storage.
  
3. Audio Speakers                                For generation of audible alarm and alert tones.
  
4. Battery Compartment                        Allows authorized service personnel easy access to the battery, EPROMS, and battery fuse.
  
5. Fuse Compartment                            The power cord cover must be removed to access the fuses.
  
6. Power Cord                                    Removable only by authorized service personnel.
  
7. PANEL LOCK Switch                         Disables all front panel keys, except BACKLIGHT and TOT VOL/STATUS, while the pump is running without alerts.
  
8. COMMUNICATIONS PORT                    The communications port contains wiring for a nurse call jack as well as RS-232 serial communications. See the Technical Specifications listed previously in this section.
  
9. VOLUME Knob                                 Adjusts loudness of audible alarm and alert tones. The audible alarm cannot be turned completely off.

## 1.5 Configuration Option Feature

This section describes the configuration option feature of the device, which allows qualified personnel to inspect and/or modify certain device operating parameters to suit customer requirements.

These parameters and their setting options are shown in Table 1-1. The factory settings made at the time of manufacture are also shown in the table.

**Note:** Although the configuration option data is stored in battery backed-up RAM, it may be lost if the main battery connector (CN302) is disconnected from the CPU board without turning off the device. The configuration option data is also lost if the lithium backup battery connector (CN304) is disconnected while the main battery is disconnected. Therefore, we advise that the configuration options be recorded before beginning repair procedures and reset when repairs are complete.

### 1.5.1 Reviewing the Configuration Option Settings

To view the configuration option settings, both pumps must be on and stopped. Press TIME and TOT VOL/STATUS simultaneously for one second. The message **REVIEW CONFIG** will be displayed in the Pump 1 Message Display. The option description will be displayed in the first line of the Pump 2 Message Display when the NEXT or SEC START key is pressed, beginning with **OCCLUSION**. The current setting will be displayed on the second line.

To view the next setting, press the NEXT or SEC START key. Each press of the NEXT or SEC START key will cause the device to advance to the next setting, in the order shown in Table 1-1, starting with Occlusion Alarm Level. To exit the inspection mode, press and hold the STOP key and the TIME key, while pressing the TOT VOL/STATUS.



## 1.5.2 Modifying the Configuration Option Settings

1. Turn off the device.
2. Press and hold either STOP key and the PANEL LOCK switch while pressing either ON-OFF/CHARGE key. The following will occur:
  - a. The **MODIFY CONFIG** message appears in the Pump 1 Message Display.

**Note:** If the message **LOCKED OUT** is displayed, the configuration option settings can be changed only via computer control. See the Programmer's Manual for additional information.

- b. The parameter descriptor appears in the first line of the Pump 2 Message Display when the NEXT or SEC START key is pressed.
  - c. The current parameter setting appears in the second line of the Pump 2 Message Display.
  - d. The programming displays are blank.
3. Press the NEXT or SEC START key to advance to the desired parameter. The parameters appear in the order shown in Table 1-1.
4. To change the settings, enter the desired value on the front panel. The selected numeric value will be displayed in the Pump 2 Primary Rate display until the value is locked in by the PRI START key, or the next parameter is displayed by pressing the NEXT or SEC START key.

**Note:** The alarm log for each pump can be cleared via the configuration option. See Table 1-1.

5. To lock in the selected value, press the PRI START key. The selected value will then be displayed in the Pump 2 Message Display. To move on to the next parameter, press the NEXT key or SEC START key.
6. To exit, press the ON-OFF/CHARGE key pressed in step 2.

**Table 1-1. Configuration Options**

Parameter Description	Setting Options	Factory Settings
<b>1. Alarm Log</b> Clear alarm/failure codes of Pump 1 or Pump 2. Select 1 or 2 to clear the corresponding pump's alarm log.	N/A	N/A
<b>2. Occlusion Alarm Level</b> The increase in pressure required to trigger a downstream occlusion alarm.	1: <b>LEVEL 1</b> (approx. 7 psi) 2: <b>LEVEL 2</b> (approx. 12 psi) 3: <b>LEVEL 3</b> (approx. 17 psi)	LEVEL 1
<b>3. Audible Switchover</b> Determines whether or not an audible alert tone will be generated when either pump switches from the secondary program to the primary program.	1: <b>OFF</b> 2: <b>ON</b>	OFF
<b>4. Number of Automatic Restarts</b> Determines whether or not the pump will automatically restart after a downstream occlusion, and if so, how many restarts can occur before the pump will remain in alarm. If this parameter is set to anything other than 0, it is enabled. The selected number corresponds to the number of automatic restarts. If set to 0, the feature is disabled.	0 - 9	3
<b>5. Door Open Required</b> Determines if the pump door must be opened after a downstream occlusion alarm. If the door is not opened and the pump is started within two minutes of the alarm, the pump uses the pressure at which the alarm occurred as the baseline for the next alarm. You may wish to set this option to force the user to open the pump door. This action resets the baseline and encourages the user to relieve the downstream pressure, thereby lowering the alarm threshold. <b>Example:</b> Suppose the initial pressure is approximately 1 p.s.i. and the occlusion alarm is set to LEVEL 1 or approximately 7 p.s.i. The first alarm will occur at approximately 1+7 or 8 p.s.i. This value represents the baseline pressure that will be used to calculate the next alarm unless the door is opened, the downstream pressure is relieved, and a new baseline is set.	1: <b>OFF</b> 2: <b>ON</b>	OFF
<b>6. Air Bubble Alarm Size</b> Determines the air bubble size which will cause an AIR alarm.	1: <b>MIN</b> (average 50 µL) 2: <b>NORM</b> (average 75 µL)	NORM
<b>7. Alarm Off Interval</b> Sets the number of seconds between each occurrence of the three-beep alarm tone.	1 - 7	1

<b>Table 1-1. Configuration Options</b>		
<b>Parameter Description</b>	<b>Setting Options</b>	<b>Factory Settings</b>
<b>8. Alert Off Interval</b> Sets the number of seconds between each occurrence of the one-beep alert tone.	1 - 7	7
<b>9. Maximum Rate of Infusion</b> Sets the maximum programmable primary infusion rate of both pumps. When the maximum primary rate is 999 or higher, the maximum secondary rate is 999. At values below 999, the maximum secondary rate matches the value of the maximum primary rate.	1 - 1999 mL/hr	1999 mL/hr
<b>10. Maximum VTBI</b> The maximum volume that either pump can be programmed to infuse.	1 - 9999 mL	9999 mL
<b>11. Flow Check Display</b> Determines whether the flow check display will appear during pump operation, or only when the decimal point key and TOT VOL/STATUS keys are pressed simultaneously.	1: OFF 2: ON	OFF
<b>12. Baud Rate</b> Determines the baud rate for normal communications between the device and a computer. The baud rate is 9600 when the device is in modify configuration mode.	1: 300 2: 1200 3: 2400 4: 4800 5: 9600	9600
<b>13. Computer Control</b> Determines the type of computer control option available at power up.	1: <b>Disabled</b> 2: <b>Off with Alarm</b> The pump will drop out of remote control when an alarm occurs. 3: <b>On with Alarm</b> The pump will remain in remote control when an alarm occurs. See the Programmer's Manual for additional information.	Disabled
<b>14. Hospital Area Designator</b> Determines the hospital area designator to be displayed upon power ON for 3 seconds. These messages can be redefined using the computer communications feature.	0: HAD (no message) 1: NICU 2: PICU 3: MED/SURGICAL 4: TRAUMA/BURN UNIT 5: OPER ROOM 6: CARDIAC/ICU 7: SURGICAL/ICU 8: ICU 9: ONCOLOGY	no message
<b>15. Close Clamp Message</b> Determines whether or not the <b>CLOSE CLAMP</b> message appears with the <b>DOOR OPEN</b> message.	1: OFF 2: ON	ON

**Table 1-1. Configuration Options**

Parameter Description	Setting Options	Factory Settings
<p><b>16. Insert Clamp Message</b>                      Determines whether or not the slide clamp loading feature is enabled. The spring retainer must be removed when this feature is enabled. See Sections 6.3.14 and 6.3.15.  <b>Note: The alarm option is available only on pumps running software versions 1.09 or later.</b></p>	<p>1: <b>OFF</b> (The spring retainer should be installed.)                      2: <b>ON</b> for software versions earlier than 1.09 or <b>ALERT</b> for 1.09 or later (An audible alert occurs and the message <b>INSERT SLIDE CLAMP</b> is displayed. The pump continues pumping.)                      3: <b>ALARM</b> (An audible alarm occurs and the message <b>INSERT SLIDE CLAMP</b> is displayed. The pump will not operate.)</p>	<p>OFF</p>
<p><b>17. Programmed Delivery Profile</b>                      Determines the memory to store the programmed delivery profile.</p>	<p>1: Disabled                      2: 5 hour memory                      3: Semi-permanent memory                      4: Permanent memory</p>	<p>Disabled</p>
<p><b>18. Time Setting</b>                      Set the real time clock in hours and minutes. (military time 00:00 - 23:59)</p>	<p>—</p>	<p>Central Standard Time - CST</p>
<p><b>19. Date Setting</b>                      Set the date using the Month/Day/Year format.</p>	<p>—</p>	<p>Current date - CST</p>

## 1.6 Alarms

The device has a number of built-in safety features. Should a situation occur which requires operator attention or intervention, the pump stops infusing and sounds an audible alarm. The following are brief descriptions of these alarms.

**AIR** An ultrasonic sensor in each pump head detects air in the administration set. Detection of an air bubble stops the infusion and illuminates the red ALARM LED. **AIR** is displayed in the appropriate Message Display and the audible alarm is activated.

**OCCLUSION** The downstream occlusion sensor senses an increase in back-pressure between the patient and the pump, indicating an occlusion or closed clamp. When an occlusion is sensed, the pump stops, **OCCLUSION** is displayed in the appropriate Message Display, the red ALARM LED is illuminated and the audible alarm is activated.

**UPSTREAM OCCLUSION** The upstream occlusion sensor senses a closed clamp or complete blockage upstream of the pump. When sensed, the pump stops, **UPSTREAM OCCLUSION** is displayed in the Message Display, the red ALARM LED is illuminated, and the audible alarm is activated.

**BATTERY LOW** When approximately 15 minutes of running time remains during battery operation, **BATTERY LOW** is displayed in both Message Displays, the yellow ALERT LEDs are illuminated, and the audible alert is activated. After approximately 15 minutes, the device stops, **BATTERY LOW** is displayed on both Message Displays, the red ALARM LEDs are illuminated, and the audible alarm is activated.

Table 1-2 lists the alarms and the possible causes of each. In all cases, fluid infusion is halted. See Section 5 for an explanation of how to troubleshoot the device.

**Table 1-2. Alarm Messages**

<b>Alarm Message</b>	<b>Possible Cause</b>
<b>AIR</b>	<ul style="list-style-type: none"> <li>a. Air bubble at sensor.</li> <li>b. Empty fluid container.</li> <li>c. Improper set loading.</li> <li>d. A <b>START</b> key was pressed with no set in pump.</li> </ul>
<b>OCCLUSION</b>	<ul style="list-style-type: none"> <li>a. Closed distal clamp, stopcock, clogged filter, kinked tubing or other blockage downstream of the pump.</li> <li>b. Ambient and/or solution temperature is too low.</li> </ul>
<b>UPSTREAM OCCLUSION</b>	<ul style="list-style-type: none"> <li>a. Closed clamp or other blockage upstream of the pump.</li> <li>b. Pinched or kinked tube loaded in the pump.</li> <li>c. Improper set loading.</li> </ul>
<b>DOOR OPEN</b>	Door must be fully closed with tubing properly loaded for the pump to operate. The door latch must be pushed down completely.
<b>FAILURE</b> with code number	Turn the pump power off and back on to reset. If <b>FAILURE</b> does not clear, the microprocessor has detected a pump malfunction. After recording the code number, remove the device from use and have it serviced. See Section 5 for more detailed service instructions.
<b>COMMON FAILURE</b> with code number	Turn both pumps off and back on to reset. If <b>FAILURE</b> does not clear, the microprocessor has detected a device malfunction. After recording the code number, remove the device from use and have it serviced.
<b>BATTERY LOW</b> with rapid three-beep alarm tone	Battery power has been exhausted. Plug device into AC outlet immediately to restore operation.
<b>CHECK SET LOADING</b>	The tubing is pinched between the pump head door and base plate. Load set properly in the IV set loading path.
<b>COM TIMEOUT</b>	There has been no communication between the device and the computer for the specified time period. Check for a disconnected cable or computer problem. To clear this alarm, press the <b>OPTIONS</b> key to return the device to computer control, or press <b>SILENCE</b> or <b>PUMP 1</b> or <b>PUMP 2</b> to use the pump(s) without the computer.
<b>EXT COMM ERROR</b>	The controlling computer is sending multiple queries or commands to the device without waiting for the device's replies. The condition has been caused by the computer, not the device. To clear the alarm, press the <b>OPTIONS</b> key to return the device to computer control, or press <b>SILENCE</b> or <b>PUMP 1</b> or <b>PUMP 2</b> to control the pump(s) manually. Notify the technical personnel responsible for the computer. If the alarm recurs, disconnect the cable from the communications port. Reprogram the pump(s) for manual operation.
<b>INSERT SLIDE CLAMP</b> Note: This alarm option is available only on pumps running software versions 1.09 or later.	The slide clamp loading option is enabled and the slide clamp is not loaded in the slide clamp slot. To clear this alarm, open the pump door and insert the slide clamp into the slot. Close the door.

## 1.7 Alerts

Alert messages call attention to a condition which will require operator intervention in the near future, or indicate that a procedure has been initiated which requires that the operator complete a sequence of keystrokes. These alerts are generally cleared by the operator taking the appropriate action.

Table 1-3 lists the various alerts and possible causes.

<b>Table 1-3. Alert Messages</b>				
<b>Alert Message</b>	<b>LED</b>	<b>Flow Status</b>	<b>Key Pressed</b>	<b>Alert Condition</b>
<b>STOPPED</b>	Yellow	No flow	None	Either pump has been left in the STOPPED mode for more than two minutes.
<b>KVO PRI VTBI = 0</b>	Green, Yellow	KVO rate	None	Primary VTBI has been delivered and the pump has switched to 5 mL/hr KVO rate (or programmed rate, whichever is lower).
<b>NEW RATE</b>	Green, Yellow	No change until procedure is completed	<b>PRI or SEC RATE</b>	Primary or Secondary flow rate is being changed while pump is running. Pump will not exit this alert condition until the appropriate <b>START</b> key is pressed.
<b>PRI RATE = 0</b>	Yellow	No flow	<b>PRI or SEC START</b>	The pump cannot be started without entering a primary flow rate.
<b>BATTERY LOW</b> with intermittent audible alert	Green, Yellow	No change	None	Battery needs recharging. The device will stop operating in approximately fifteen minutes or longer unless it is plugged into an AC source.
<b>SEC PRO-GRAM</b>	Green, Yellow	No change	<b>SEC RATE or SEC VTBI</b>	Secondary (piggyback) information is being programmed into a pump while it is running. Pump will not exit this alert condition until <b>SEC START</b> is pressed.
<b>SEC RATE = 0</b>	Yellow	No flow	<b>SEC START</b>	A secondary (piggyback) infusion cannot be started unless a secondary flow rate is input.
<b>SEC VTBI = 0</b>	Yellow	No flow	<b>SEC START</b>	A secondary (piggyback) infusion cannot be started unless a secondary volume to be infused has been input.
<b>SEC COMPLETE</b>	Yellow	No change	None	The pump has completed infusing the secondary VTBI and has switched over to the primary infusion settings. Pump will not exit this alert condition until any enabled key is pressed.
<b>FLOW RATE</b>	Yellow	No flow	<b>PRI or SEC START</b>	Enter a rate within the range selected through the configuration option. The pump cannot be started when <b>Hi</b> or <b>Lo</b> is displayed in a rate display.
<b>CHECK VTBI</b>	Yellow	No flow	<b>PRI or SEC START</b>	The pump cannot be started when <b>Hi</b> is displayed in a VTBI display. Enter a VTBI within the range selected through the configuration option.

**Table 1-3. Alert Messages**

<b>Alert Message</b>	<b>LED</b>	<b>Flow Status</b>	<b>Key Pressed</b>	<b>Alert Condition</b>
<b>INSERT SLIDE CLAMP</b>	Yellow	No flow or flow if started	Closed door, <b>PRI</b> or <b>SEC START</b>	Slide clamp is not loaded into the slide clamp slot although the set is loaded into the pump.
<b>COM TIMEOUT</b>	Yellow	No change or no flow	None	Communication timeout period has elapsed. No communication has occurred between the device and the host computer during the power-up default time period (60 seconds) or during the time period most recently specified by the host computer (1–300 seconds). The computer and the device must maintain periodic and successful communication in order to avoid this timeout alert. See the Programmer's Manual for further information.
<b>EXT COMM ERROR</b>	Yellow	No change	None	The controlling or monitoring computer is sending multiple queries or commands to the device without waiting for the device's replies. The condition has been caused by the computer, not the device. To clear the alert, press <b>OPTIONS</b> to return the device to computer control (if appropriate), or press <b>SILENCE</b> or <b>PUMP 1</b> or <b>PUMP 2</b> to control the pump(s) manually. Notify the technical personnel responsible for the computer. If the alert recurs, disconnect the cable from the communications port. Reprogram the pump(s) for manual operation.
<b>PGM DELIV ENTER PGM</b>	Yellow	No flow	<b>PRI</b> or <b>SEC START</b>	An attempt was made to start the PDP before a program was entered. Enter a program or press <b>OPTIONS</b> to leave the PDP mode.
<b>PGM DELIV REVIEW PGM</b>	Yellow	No flow	<b>PRI</b> or <b>SEC START</b>	An attempt was made to start a PDP profile prior to reviewing all the programmed steps. Press <b>NEXT</b> until the first step is again displayed, or press <b>OPTIONS</b> to leave the PDP mode.
<b>PGM DELIV CLEAR ALL?</b>	Yellow	No flow	<b>CLR</b>	The <b>CLR</b> key was pressed after entering the PDP mode to clear all steps. Do one of the following: press <b>CLR</b> to erase the profile; press <b>NEXT</b> to review the rest of the profile; press <b>PRI RATE</b> or <b>PRI VTBI</b> to modify this step; press <b>OPTIONS</b> to leave the PDP mode.



## Section 2

---

# Hospital Service Procedures

This section contains a table describing preventive maintenance performed on Flo-Gard® 6301 Dual Channel Volumetric Infusion Pump in the hospital. The maintenance procedures outlined in this section may be performed in the hospital. If an abnormal condition occurs which is not correctable by performing the following procedures, remove the device from service and troubleshoot it in accordance with Section 5, or return it to Product Service for repair.

### 2.1 Replacement Of Main Power Fuse

1. Plug the device into an AC power outlet.
2. Check if the Plug Icon is illuminated.
3. If it is not, replace the fuse. Remove the power plug from the AC power outlet.
4. Remove the power cord cover on the back of the device, and unscrew the fuse caps with a small screwdriver.
5. Remove the fuses and check them for electrical continuity with an ohmmeter.
6. If necessary, replace with a new fuse of the same value, type and voltage.
7. Replace and tighten the fuse caps with a screwdriver. **Over tightening the fuse caps may cause the fuse holders to break.**
8. Replace the power cord cover.
9. Perform the Electrical Safety Test to verify proper grounding impedance. See Section 7.3.13.

### 2.2 Cleaning

The device should be cleaned as soon as possible after each use to minimize the accumulation and hardening of spilled solutions. The case and front panel may be cleaned with a soft cloth or cotton swabs dampened with a properly diluted cleaning agent listed in Table 2-1.

Be sure to follow the manufacturer's dilution instructions for concentrated cleaners where applicable. Do not spray cleaning agents directly onto the inside of the pump door, the pump mechanism, and the front panel film. If these areas require cleaning, wipe carefully with a soft cloth, sparingly dampened with a cleaning agent listed in Table 2-1. If solution spillage onto the pumping mechanism or front panel occurs, it should be cleaned immediately. If necessary, contact Product Service at 1-(800)-THE-PUMP.

**Table 2-1. Cleaning Solutions**

<b>CLEANER</b>	<b>MANUFACTURER</b>
LpH, Septisol	Vestal Labs, Inc.
Cidex 7	Surgikos Inc.
Super Edisonite	Edison Chemical Co.
Bafix	Hysan Corp.
Tor	Huntington Labs.
Hi-Tor Plus	Huntington Labs.
10% bleach and water	
Soapy water	
Isopropyl alcohol (up to 95%)	

**Caution:** Attempts to clean or disinfect internal parts, autoclaving or sterilization by ethylene oxide gas will damage the device and void the warranty.

**Caution:** The following chemicals may damage the plastic front panel and tube misloading sensors: Acetaldehyde, Acetone, Ammonia, Benzene, Hydroxytoluene, Methylene Chloride, n-Alkyl Dimethyl Ethyl Benzyl Ammonium Chloride, and Ozone.

For a device that has been in an Isolation Area, select those agents from Table 2-1 that both clean and disinfect. Only external parts of the device should be disinfected. The following are procedures for cleaning accessible areas of the device. **Do not use hard instruments for cleaning.**

1. Lift the door latch to the open position. Open the door and press the safety clamp latch until it locks in the open position.
2. Using a cotton swab dampened with one of the agents listed in Table 2-1, clean all tubing guides and tubing channels from the top of the pump to the exit point below the safety clamp. Clean all surfaces in the pump head which may contact the tubing.
3. Clean all surfaces of the air sensor located just above the safety clamp. This area must be completely dry and free of foreign matter prior to reuse.

## 2.3 Battery Charging

The battery is recharged whenever the device is plugged in regardless of whether the pumps are on or off. However, for optimal charging, turn the pumps off. The Plug Icon is illuminated whenever the battery is charging. The battery must be stored in a charged condition and should be recharged at least once a month. To charge the battery, plug the device into a 115 VAC outlet.

## 2.4 Preventive Maintenance

Table 2-2 lists preventive maintenance for the device, which should be performed at the intervals shown.

<b>Table 2-2. Preventive Maintenance Procedures</b>	
<b>CHECK</b>	<b>ACTION</b>
<b>Schedule: As required, but recommended after every use.</b>	
Rear panel connector (comm port)	Clean with an agent listed in Table 2-1. Replace the connector if its shell is damaged. Check that plastic cover is in place.
Pump mechanism	Clean with an agent listed in Table 2-1.
Case	Clean with an agent listed in Table 2-1.
Loose or missing hardware	Replace in accordance with Section 6.
Main battery	Recharge by plugging into a 115 VAC outlet for at least 8 hours. Check that the Plug Icon is illuminated during this time.
<b>Schedule: Every 12 months or as required.</b>	
Back plate and safety clamp	If the back plate does not operate smoothly, clean or replace in accordance with Section 6.3.17.
Pole clamp	If operation is not smooth, apply one drop of high grade general purpose machine oil to the screw threads.
Power cord	Replace the power cord if the pins are bent or the insulation is damaged.
Preventive maintenance tests	Perform the appropriate tests as detailed in Section 7.3 Operational Checkout.



## Section 3

# Problem Checklist

Table 3-1 is a list of problems, checks and corrections to aid in the diagnosis of possible pump malfunctions. Corrections contained in the table can be performed without opening the device housing. Review this list whenever a condition exists that does not appear to be normal. Perform the specified checks and corrections. If the problem cannot be corrected, remove the device from service. Troubleshoot it in accordance with Section 5 and repair it in accordance with Section 6.

Table 3-1. Problem Checklist		
PROBLEM	CHECKS	CORRECTIVE ACTION
The plug icon is not lit when the device is plugged in, or the battery icon is lit when the device is plugged in.	Check the tightness of the power plug into the AC outlet.	Press the power plug firmly into the grounded AC outlet.
	Check the rear power fuses under the power cord cap.	Replace the fuse(s) if it has failed and recharge the battery.
	Check the AC outlet for proper voltage.	If the voltage is below 105 VAC, connect the device to the correct supply voltage.
	Check the line cord for continuity.	Connect the power terminals of the power plug to an ohmmeter. The ohmmeter should indicate continuity.
The device fails to run on the internal battery (No LCD displays appear).	After recharging the battery for 24 hours with the device turned off, check the battery charging voltage, MB, per Section 5.3.1.	If the battery charge voltage is normal and the problem still persists, replace the battery. See Section 6.3.18.
A pump stops with <b>BATTERY LOW</b> alarm.	No check required.	Recharge the battery.
The audible alarm volume is not loud enough.		Turn the <b>VOLUME</b> knob on the rear of the device clockwise until the desired volume is obtained.
The interval between audible alarm tones is too long.		Change the interval for alert and/or alarm tones to the desired value through the configuration option.

**Table 3-1. Problem Checklist**

PROBLEM	CHECKS	CORRECTIVE ACTION
The pump door will not open or close smoothly.	Check the positioning and seating of the administration set tubing and the slide clamp.	Position the tubing and slide clamp properly and make certain the tubing is seated in the guides and channels with the safety clamp open and the slide clamp is in the slot. Close the pump door.
	Check the administration set for type and code.	Replace with a Baxter's "s" suffix administration set, if required.
	Check for solution spills (liquids or residues).	Clean all accessible areas with cotton swabs dampened with one of the cleaners listed in Section 2. Remove fibers or foreign particles. Do not use hard instruments for cleaning.
	Check that the door latch roller pin turns smoothly.	Clean the roller with an approved cleaner.
	Check for possible damage to the door latch, latch pin roller, or door hinge.	See Section 6.3.5 for instructions on replacing the door latch and Section 6.3.7 for replacing the latch pin. Replace the door as described in Section 6.3.6.
The backlight is off when the device is running on internal battery power.		Press the <b>BACKLIGHT</b> key as long as required to view the pump settings.
A <b>RATE</b> , <b>VTBI</b> , or <b>START</b> key is not accepted by the pump	Check if the front panel is locked ( <b>Loc</b> appears in the Main Display).	Press the <b>PANEL LOCK</b> switch to remove the panel lock.
<b>Hi</b> or <b>Lo</b> is displayed during Volume-Time programming.	Calculate the rate and verify that it is within the allowable range set by the configuration option.	Enter a rate within the range set by the configuration option or change the maximum rate setting in the configuration option if appropriate.
A <b>FLOW RATE</b> or <b>CHECK VTBI</b> alarm occurs when a <b>START</b> key is pressed.	Check that the rate or VTBI are within the limits set by the configuration option.	Change the maximum rate and/or maximum VTBI setting through the configuration option.

<b>Table 3-1. Problem Checklist</b>		
<b>PROBLEM</b>	<b>CHECKS</b>	<b>CORRECTIVE ACTION</b>
<p>An <b>AIR</b> alarm occurs with no air in the tubing or when the pump door is closed and the <b>START</b> key is pressed.</p>	Check the positioning and seating of the tubing.	Position the tubing fully into the air sensor.
	Check the tubing for surface scratches and for tube roundness.	Replace or reposition the tubing if surface scratches are significant or if the tubing has become flattened or oval in shape.
	Check the administration set for type and code.	Replace with a Baxter's "s" suffix administration set.
	Check for solution spills (liquids or residues).	Clean the sensor with cotton swabs dampened with one of the agents listed in Table 2-1. Remove fibers or foreign particles. <b>Do not use hard instruments for cleaning.</b>
<p>An <b>OCCLUSION</b> alarm or an <b>UPSTREAM OCCLUSION</b> alarm occurs when the pump door is closed and the <b>START</b> key is pressed.</p>	Check the positioning and seating of the tubing.	Position the tubing properly into the sensor and safety clamp. Correct any pinched or kinked tubing in the pump.
	Check that there are no obstructions upstream or downstream of the pump.	Remove obstructions and/or open the roller clamp.
	Check the administration set for type and code.	Replace with a Baxter's "s" suffix administration set if required.
	Check that ambient and solution temperatures are above 60° F.	Raise ambient and/or solution temperatures.
	Check for solution spills (liquids or residues) on the inside of the door and/or on the base plate.	Clean all accessible areas with cotton swabs dampened with one of the cleaning agents listed in Table 2-1. Remove fibers or foreign particles. <b>Do not use hard instruments for cleaning.</b>
<p>An <b>INSERT SLIDE CLAMP</b> alert or alarm occurs when the pump door is closed. <b>Note: The alarm option is available only on pumps running software versions 1.09 or later.</b></p>	Check that the slide clamp is in the slide clamp slot.	Push the slide clamp all the way into the slide clamp slot.
	Check for solution spills (liquids or residues) on the slide clamp or safety/slide clamp assembly.	Clean the slide clamp and the safety/slide clamp assembly.
	Check if the administration set is equipped with the slide clamp designed for use with this pump. See the instructions accompanying the administration set.	If not, use an administration set which has the proper slide clamp for use with the pump. Insert the slide clamp into the slide clamp slot before closing the pump door.

**Table 3-1. Problem Checklist**

PROBLEM	CHECKS	CORRECTIVE ACTION
The safety clamp will not latch open.	Check the positioning and seating of the slide clamp in the slide clamp slot.	Position the clamp all the way into the slide clamp slot.
	Check if the administration set is equipped with the slide clamp designed for use with this pump. See the instructions accompanying the administration set.	If not, use an administration set which has the compatible slide clamp. Insert the slide clamp into the slide clamp slot before closing the pump door.
	Make sure the safety clamp arm cover is in the full open position.	Exercise the safety clamp by opening and closing it several times.
	Check for solution spills (liquids or residues).	Clean with cotton swabs dampened with one of the cleaning agents listed in Table 2-1. Remove fibers or foreign particles. <b>Do not use hard instruments for cleaning.</b>
A <b>CHECK SET LOADING</b> alarm occurs when the pump door is closed.	Open the door and check the position of the tubing in the guide channel.	Load the set properly in the guide channel.



---

## Theory of Operation

This section covers the operating principles of the device. The theory of operation does not cover the specific circuitry in great detail, but provides general information needed to perform fault isolation. **Active-low signals on all schematic diagrams in Section 10 are denoted by an exclamation point (!) preceding the signal name.** Figure 10-1 is a block diagram of the major components in the device. The numbers at the upper left of each block refer to the number of the figure in Section 10 in which the major components of that block are shown in greater detail.

### 4.1 CPU System

#### 4.1.1 CPUs

See Figures 10-9 through 10-16. The device uses two CPUs, U101 and U001. U101 always functions as the master CPU and U001 always functions as the slave.

The master CPU controls all device functions except motor control, which is handled by the slave CPU. The master CPU sends rate information and motor start/stop messages to the slave CPU and also monitors the motor control by the slave CPU.

The master CPU gathers data from and/or controls the interlock switches, the power control circuit, the communication controller, two I/O controllers, the occlusion detection multiplexer, the RAM, the real time clock, the air sensor, the universal pulse processor and the alarm control circuit.

The master CPU also handles RS-232 serial communication with an external computer through the communication controller.

The slave CPU mainly controls the pump motors via the motor control circuit in three ways.

- Generates pulses to rotate the motors.
- Monitors motor skip steps by checking the signals from the motor rotation detectors.
- Controls the motor currents while minimizing current draw from the battery. It also controls the alarm control circuit.

The slave CPU outputs an interrupt signal to the master CPU through the universal pulse processor after every one-eighth of the liveband period to provide air bubble detection timing to the master CPU.

Both CPUs handle the watchdog function, which is the periodic communication between the CPUs through two serial communication lines at 15,625 baud.

The CPUs utilize 16 address and 8 data lines and can access 64Kb. The master CPU addresses 128K x 8 EPROMs through 2 bank address lines.

The master CPU addresses an EPROM, RAM, Real Time Clock, universal pulse processor, two I/O controllers and the communication controller. The slave CPU addresses an EPROM, RAM and programmable timer module. Note that the EPROMs cannot be swapped between the master and the slave CPUs because the software in the master EPROM is different from that of the slave.

#### **4.1.2 Programmable Timer Module (PTM)**

See Figure 10-12. The programmable timer module, PTM, divides the 8 MHz system clock into 500 kHz for the oscillation of air sensors and also generates a signal for pulse width modulation control of the motor drivers.

The slave CPU calculates and outputs motor drive signals based on the rate information from the master CPU. It also sets motor current levels in the PTM from a reference table.

#### **4.1.3 Watchdog Function**

The watchdog function is performed in two ways.

Both CPUs monitor each other's status. The purpose of this watchdog is to detect a malfunction of either microprocessor and stop the pumps with an alarm. See Figures 10-10 and 10-16. Both CPUs communicate through the two serial communication lines, Tx and Rx. Each CPU has a communication counter which is initialized to a predetermined value by a signal from the other CPU. The counter is then decremented by one count every 32.768 mS. The counters are normally initialized again by the signal from the other CPU before they decrement to zero. If a counter reaches zero, it indicates that the watchdog signal from the other CPU was never received. This indicates a problem with the other CPU. The remaining functional CPU then stops the pumps with visual and audible alarms.

If communication between the CPUs cannot occur, both CPUs stop the pumps with visual and audible alarms.

Should both CPUs fail at the same time, this watchdog function does not work. The alarm control circuit is provided as a backup watchdog function. See Figure 10-12. Alarm signals (ALARMM, ALARMS) from each CPU are the inputs to the alarm control circuit.

When both CPUs are functioning normally, the signals change their state periodically. The software to control the signals is divided into several parts and located in different portions of the main program. The state changes of the signals are considered normal only when all the individual parts of the program are executed according to an expected sequence.

If either or both signals fail, the alarm control circuit is triggered and stops the pumps with visual and audible alarms.

The accompanying audible tone whenever either watchdog function is activated is continuous rather than intermittent.

#### **4.1.4 I/O Controllers**

See Figures 10-21 (PPI Block #1) and 10-22 (PPI Block #2). The I/O controller U601 performs the following functions: activating backlight, addressing the keyboard and scanning the ON-OFF/CHARGE key, PANEL LOCK switch and LCD drivers, and writing display data from the master CPU into the display drivers.

The other I/O controller, U602, performs the following functions: controlling the air and occlusion sensors, and activating all LEDs and icons except ALARM and OPTIONS LEDs and key beep. It also transfers the slide clamp sensor signals to the master CPU.

#### **4.1.5 Multiplexer**

See Figure 10-23. The occlusion sensing block contains the multiplexer U851, which selects one of the four occlusion sensor outputs in accordance with the address signals from an I/O controller, and sends it to the master CPU.

#### **4.1.6 Universal Pulse Processor**

See Figure 10-11. The universal pulse processor (UPP) is controlled by the master CPU and converts the following analog signals into digital signals: air sensor outputs, tube misloading detector outputs, battery voltages, motor currents and the voltage of the CPUs. The digital signals are periodically read by the master CPU.

The UPP generates 2 kHz and 4kHz signals for the audible alarm and key beep, and a 17 kHz signal for the door open detector, and the signal for backlight dimming.

The UPP also interrupts the master CPU each time a pulse is received from the motor rotation detectors, when an interrupt signal from slave CPU is received or when the device communicates with an external PC.

The UPP is used to select the baud rate for external communications. The baud rate is set at power-up according to the configuration setting.

### 4.1.7 Communication Controller

See Figures 10-11 and 10-14. The communication controller allows the device to communicate with an external computer through an RS-232C interface. The baud rate is selectable and controlled by the universal pulse processor.

### 4.1.8 Air Sensor Circuit

See Figures 10-11, 10-22, 10-24, 10-36, and 10-37. The air sensor circuits for both pumps are identical. Each circuit consists of an ultrasonic transmitter and receiver, mounted on opposite sides of the tubing path. The transmitter consists of a 500 kHz oscillator and a selector that transfers the oscillator output to two of three transducers. The transducers are selected by the air bubble alarm size setting in the configuration option. The receiver contains a selector that transfers the transducer outputs to the universal pulse processor through an amplifier.

The transducers operate on the principle that air in the tubing transmits ultrasonic energy much less effectively than fluid. This energy is amplified, rectified, applied to the UPP and then converted into a digital signal. The master CPU monitors the signal and activates an **AIR** alarm if it detects the absence of a precise level of energy.

### 4.1.9 Occlusion Sensors

#### 4.1.9.1 Downstream Occlusion Sensor

See Figures 10-10, 10-23, 10-36 and 10-37. The downstream occlusion sensor consists of a moving ferrite core inside a mechanically fixed oscillator coil. The moving ferrite core is spring loaded against the IV set tubing. When pressure downstream of the pump increases, the core moves from its original position, which in turn changes the frequency of the oscillator.

One of the two downstream occlusion sensor outputs is selected by the multiplexer, applied to the master CPU, and compared to the occlusion level selected in the configuration option. If the occlusion is sufficient to cause a specific frequency change, the CPU activates an alarm. There is a maximum expansion of the tubing beyond which the pump will no longer permit operation.

The downstream occlusion sensor operates in a frequency range of 1.3 MHz to 1.45 MHz.

#### 4.1.9.2 Upstream Occlusion Sensor

See Figures 10-10, 10-23, 10-36, and 10-37. The upstream occlusion sensor is similar to the downstream occlusion sensor (except for the spring) but is not tuned to the same frequency and is controlled by different software.

One of the two upstream occlusion sensor outputs is selected by the multiplexer and applied to the master CPU. Because the tubing collapses somewhat during normal operation, the software looks for a collapse that is faster and/or farther than expected. If the rate of collapse is too fast or

too far, the pump alarms. There is a maximum tubing collapse beyond which the device will no longer permit operation.

The upstream occlusion sensor operates in a frequency range of 1.2 MHz to 1.35 MHz.

#### 4.1.10 Tube Misloading Detectors

See Figures 10-11, 10-25, 10-36 and 10-37. Each pump head has a Force Sensing Resistor\* (*FSR\*\**) device attached to each side of the tube loading channel. If the tube is misloaded over the *FSR*, its resistance decreases. The two *FSR* output voltages of each pump are converted into digital signals by the UPP and monitored by the master CPU. The CPU activates an alarm when the resistance reduces below a specified level.

#### 4.1.11 Slide Clamp Detectors

See Figures 10-22, 10-25, 10-36 and 10-37. Each slide clamp detector consists of two opto-interrupters contained in the safety/slide clamp assembly. If the slide clamp option is selected via the configuration option settings, the administration set slide clamps should be loaded into the slide clamp slots in order to avoid an alert or alarm condition. If the slide clamps are not loaded into the slide clamp slots, or are loaded improperly, the opto-interrupters do not receive reflection signals. The interrupter output voltages are read and monitored by the master CPU via the I/O controller. The CPU activates an alert or an alarm (software versions 1.09 or later) when the slide clamps are not loaded and the option has been selected.

#### 4.1.12 Battery Low Alert/Alarm Detector

See Figures 10-7 and 10-11. The battery voltage is converted into a digital signal by the UPP and monitored by the master CPU. The CPU activates the alert or alarm if the battery charge state falls too low.

The **BATTERY LOW** alert is triggered if the battery voltage drops below 11.4 VDC, which will permit approximately 15 minutes of operation. The **BATTERY LOW** alarm is triggered when battery voltage drops below 10.4 VDC, which stops the pumps with alarms to prevent the battery from being damaged.

#### 4.1.13 Interlock Switches

See Figures 10-10, 10-36 and 10-37. The interlock switches are reed type, activated by a magnet attached to each pump door latch. The switch opens the circuit when a pump door is opened. The master CPU monitors the interlock switches, activates the **DOOR OPEN** alarm and stops the appropriate pump when its door is opened.

\* Interlink Electronics

\*\*Interlink Electronics

#### 4.1.14 Panel Lock Circuit

See Figures 10-3, 10-21, 10-34, and 10-35. The panel lock circuit is initiated by the PANEL LOCK pushbutton switch located on the rear of the device. The switch is connected to an I/O controller. The purpose of this circuit is to prevent patient tampering. After the PANEL LOCK switch has been pressed, the message **Loc** is displayed in the unused rate window and no keys except TOT VOL/STATUS and BACKLIGHT are accepted. The panel lock out is released by pressing the PANEL LOCK switch again. The switches are enabled only when the pumps are running.

#### 4.1.15 Keypad

See Figures 10-21 and 10-38. The keypad is a multiplexed 8 x 4 array which is scanned by an I/O controller. One of eight select lines determines which four keys are read. All normal keypad presses are decoded by this matrix except the ON-OFF/CHARGE keys, which have special inputs to the power control circuit.

#### 4.1.16 Displays

See Figures 10-26 through 10-31. The LCD displays are multiplexed by display drivers, which apply a DC biased free-running frequency AC voltage to the segments of the displays when in the ON state, and no DC biased AC voltage when in the OFF state. The display drivers are addressed by the master CPU through an I/O controller. The data is sent on the data bus and is coded to update the displays periodically. Once addressed, the display driver retains the data until addressed again. The entire display is updated every 128 msec.

The display backlight is toggled on or off by the BACKLIGHT key. If the device is running on AC power, the backlight stays on continuously. If the device is running on the battery, the backlight shuts off after 60 seconds to conserve battery life.

#### 4.1.17 Motor Driver

See Figures 10-18 and 10-19. There is a separate motor driver circuit for each pump that functions identically. Each motor driver receives four separate motor drive signals from the slave CPU, which are effectively ANDed with a pulse width modulation (PWM) signal from the programmable timer module. The PWM signal controls the current level required for proper motor operation. The motor current level is converted into digital signal by the UPP and monitored by the master CPU, which activates an alarm and stops the pump if a motor overcurrent is detected. The user-defined rate is saved in two different memory locations which are compared against each other and the feedback from the motor rotation detectors to guard against any non-programmed rate changes.

Snubbing diodes have been added to increase motor efficiency. The motor is shut down when an alarm or a failure occurs. The motor speed range permits infusions from 1 mL/hr to 1999 mL/hr.

### 4.1.18 Motor Rotation Detectors

See Figures 10-11, 10-16, 10-18, 10-19, 10-36 and 10-37. The motor rotation detectors assure that pump drive rotation occurs or the motor shuts down. The motor rotation signals are read by the master CPU via the UPP and slave CPU. The sector signals are read by the slave CPU and utilized for controlling motor currents.

## 4.2 DC Power Supply and Power Control Circuit

See Figures 10-5 through 10-8. The DC power supply circuit is a switching type, which provides a regulated 13.65 V output at 1.4A maximum. The circuit will charge the battery as long as the device is connected to a specified AC outlet. The design continues to supply useful output down to a 105.0 VAC input. Two 500 mA slow blow replacement fuses are required for AC. A 2.0A fuse is required in the battery circuit. Whenever the supply is activated by AC voltage, the Plug Icon on the front panel is lit. The DC power supply has over-voltage and over-current protection.

The power supply circuit on the CPU board (Figure 10-8) generates several DC sources from the 13.65 V output of the DC power supply board, (when the device is plugged into a specified AC source) or from the internal battery. The +5 VDC lines are shown below. See Section 6.4.1 for voltage specification limits.

**V<sub>cpu</sub>**: This line is the output of a DC to DC convertor, HIC301, and is switched by the master CPU. V<sub>cpu</sub> is the main DC source voltage of the device. **Motor current does not flow while V<sub>cpu</sub> is off.**

**V<sub>ref</sub>**: This is the reference voltage regulated by a filter and a reference diode U502: LM336M-5.0 (Figure 10-7) for the A/D convertor in the UPP. This voltage is generated from V<sub>oth</sub>, which is switched by the master CPU.

**V<sub>key</sub>**: This is generated either from the output of the DC power supply board, or from the internal battery voltage and is used for monitoring the ON-OFF/CHARGE key. This is the unswitched power source.

Other DC voltages used in the device are:

**V<sub>mtr</sub>**: This is the DC source for the motors. It comes either from the DC power supply output or the internal battery voltage. This is the unswitched power source.

**V<sub>oth</sub>**: This is used for backlights, icons and optional nurse call feature. The voltage comes from the DC power supply output and is switched by the master CPU.

**V<sub>mem</sub>**: This is the output of the lithium backup battery for the backup memory in the RAM (U507) and for maintaining the time in real time clock (U506). This is the unswitched power source.

All the voltages except unswitched power sources are turned on when the ON-OFF/CHARGE key is pressed while the device is off. However, turning these voltages off can only be accomplished by the master CPU through the power control circuit.

The master CPU saves necessary data in the backup memory in the RAM (U507) and turns off the V<sub>cpu</sub>, V<sub>ref</sub> and V<sub>oth</sub> voltages when both pumps are turned off.

The power control circuit is contained in a hybrid chip, HIC302, which also includes a circuit to activate the backup audible alarm when the device is shut down by a failure. The RAM (U006) for the slave CPU is not backed up.



### 5.1 Introduction

This section describes how to find the cause of device malfunctions. The section consists of the following:

- A description of the device's failure identification codes.
- A description of the device's automatic test modes.
- A table which lists each failure code, its cause, and ways of correcting it.
- A table which describes how to correct problems not represented by failure codes.

Once the cause of a failure has been determined, perform the corrective action given in the table. All disassembly/reassembly and calibration procedures for the device are in Section 6. To verify the effectiveness of repairs after they are completed, perform the Operational Checkout procedures given in Section 7.

### 5.2 Failure Identification Codes

Specific errors which may occur during device operation are represented by failure identification codes. When the alarm message **FAILURE** or **COMMON FAILURE** occurs, it is accompanied by a two-digit code number. This code is the failure identification code. The last 10 failure identification codes (including alarms for each pump except **DOOR OPEN** and **AIR** alarms occurring in the stopped mode) are stored in the device's memory along with the date and time at which the alarm occurred. The failure identification codes can be used to determine the nature of a device failure and to troubleshoot its cause.

To view the stored failure identification codes, press the STOP key(s). Press and hold the SILENCE and TOT VOL/STATUS keys. The most recent failure identification code(s) will be displayed in the lower right corner of the appropriate Main Display. The time at which the failure occurred will be displayed in the upper right corner of the appropriate Main Display. The date when the failure occurred will be displayed in the appropriate Message Display for as long as the keys are held, plus one second. To exit from the failure identification code viewing mode, release the SILENCE and TOT VOL/STATUS keys. One second later, the display of the RATE(s) and VTBI(s) data resumes. To scroll back through the previous nine codes that occurred, press the CLEAR TOT VOL key before the one second period elapses. Each failure code, along with the time and date, will be displayed for one second with a one second off interval after each

code. After the last failure code for the pump(s) has been displayed for 1 second, the display(s) return to normal. To exit, press the appropriate STOP key(s).

See Table 5-1 for descriptions of all failure identification codes and instructions on how to correct each failure. Disassembly/reassembly and calibration procedures are located in Section 6

During operation, a pump-specific failure is indicated by the message **FAILURE** and the failure code number (in the format, F\_nn) in the appropriate Message and Main Displays. A device specific-failure is indicated by **COMMON FAILURE** in the Pump 1 Message Display and the failure code number in the Pump 2 Main Display.

### 5.3 Automatic Test Modes

**Warning: The automatic test modes are for servicing the device only, and must not be used while the device is connected to a patient.**

The device has ten automatic test modes to aid in troubleshooting and manufacturing. The ten modes are described briefly in the following paragraphs. The procedure to access any of the automatic test modes is as follows:

1. Turn off the device.
2. Press and hold the CLEAR TOT VOL key and while pressing the numeric key corresponding to the automatic test mode you wish to enter (1 through 0).
3. While performing step 2, press either ON-OFF/CHARGE key.
4. To exit any automatic test mode, press the ON-OFF/CHARGE key that was pressed in step 3.

#### 5.3.1 Automatic Test Mode 1: Calibration Mode 1

The purpose of this calibration mode is to check the calibration of the upstream and downstream occlusion sensors, and to check the device's internal DC voltages from the power supply.

1. Place the device on its back. Enter Automatic Test Mode 1.
2. Place the thickness gauge (part no. UKOG1013.B) onto the downstream occlusion sensor.
3. Close the pump head door.
4. Plug the device into a  $115 \pm 5.0$  VAC, 60 Hz power source.

5. Check that the value displayed in the PRI VTBI window of the appropriate Main Display is between 2967 and 3039. No calibration is required if the values are within the specification.
6. If the value is out of specification, perform Section 6.4.3, steps 2 and 3.
7. Place the thickness gauge used in step 2 onto the upstream occlusion sensor.
8. Close the pump door.
9. Check that the value displayed in the PRI RATE window of the appropriate Main Display is between 3242 and 3314. Remove the thickness gauge, close the door, and check that the value is 3180 or less.
10. If the value is out of specification, perform Section 6.4.4, steps 2 and 3.
11. Check that the voltage readings in the SEC RATE and SEC VTBI windows of Pump 1 Main Display are within specification:

**Note:** The pump must be plugged in to obtain voltage readings within the specifications below.

Descriptor	Window Displayed	Specification
V <sub>main</sub> = MB	SEC RATE	688 - 714 (a)
V <sub>mem</sub> = BB	SEC VTBI	574 - 737 (b)

**Note:** (a) Actual voltage = Displayed data x 0.01953  
 (b) Actual voltage = Displayed data x 0.00488.

12. If the BB display is out of specification, replace the lithium backup battery per Section 6.3.26.
13. MB is a value related to the voltage of the charging circuit. If the MB display is out of specification, turn the device off and charge it for 8 hours. Repeat steps 1 and 11. If the MB display is still out of specification, perform the following procedure.
14. Remove the battery cover by removing 4 screws (Figure 8-4 item 34) on the battery cover located on the back of the device. Disconnect the main battery at the battery terminals and perform steps 1 and 11.
15. If the MB display is out of specification, the DC power supply must be calibrated per 6.4.1.

16. If the MB display is within specification as described in Step 11, the main battery should be replaced per Section 6.3.18.

### 5.3.2 Automatic Test Mode 2: Calibration Mode 2

The purpose of this automatic test mode is to check the calibration of the air sensors and to check the tube misloading sensor outputs.

Open the door and check for a white tubing guide shim or the letter "A" on the door opposite the air sensor. If the shim or "A" is present, use the air sensor calibration values of 330 - 565 (if the shim or "A" is NOT present, use the calibration values of 400 - 650).

1. Plug the device into a 115  $\pm$ 5.0 VAC, 60 Hz power source. Enter Automatic Test Mode 2.
2. Load a Baxter's "s" suffix standard administration set and prime it with fluid. Close the pump head door. **Ambient and solution temperatures must be between 72° and 82° F (22° and 28° C).**
3. Open and close the pump door two more times and wait 2 minutes.
4. Check the **NORM** value (at PRI RATE window) and the **MIN** value (at PRI VTBI window). Both values should display between 330 and 565 or between 400 and 650 (Check above for the proper values).
5. Remove the primed tubing and load an unprimed calibration tubing segment and close the door. Open and close the door two more times and wait 2 minutes. View the **NORM** value displayed in the PRI RATE location at the upper left of the device's main display. Next view the **MIN** value displayed in the PRI VTBI location at the lower left of the main display. Both values must be less than 11. If they are out of specification, perform the procedure in Section 6.4.2.
6. Follow steps 7 through 11 to check that the tube misloading sensor outputs in SEC RATE and SEC VTBI windows are within specification.
7. Load a Baxter's "s" suffix standard administration set and prime it with fluid.
8. With the pump door open, check the FSRR value (at SEC RATE window) and the FSRL value (at SEC VTBI window). Both values should be between 500 and 820.
9. Repeat above step with the pump door closed. Both values should be between 500 and 820.

10. Open the door and intentionally load the tubing over the tube misloading sensor 1L and/or 2L (Figure 8-6, item 11 and/or Figure 8-11, item 10). Close the door. **Do not load hard components on the administration set between the door and the base plate.** The FSRL value (at SEC VTBI window) should be 450 or less.
11. Repeat above step on the tube misloading sensor 1R and/or 2R (Figure 8-6, item 10 and/or Figure 8-11, item 11). The FSRR value (at SEC RATE window) should be 450 or less.

**Note:** The sensors are normal if the values in steps 8 through 11 are within specification. If any of these values are out of specification, replace the tube misloading sensor per Section 6.3.12.

12. Press the TIME key and check that the voltage reading in the Pump 1 SEC RATE window is within 472 - 579. **Actual voltage = displayed data x 0.00976.**

### 5.3.3 Automatic Test Mode 3: Manufacturing Test Mode

**Warning:** This is an automatic test mode for testing the device during manufacturing only. This mode must not be used on patients because the downstream occlusion, upstream occlusion and air sensors are disabled.

The initial display in this automatic mode is for a PRI RATE of 1999 mL/hr, PRI VTBI of 3998 mL, SEC RATE of 500 m/hr, and SEC VTBI of 100 mL. Each press of the TIME key changes the primary settings as follows:

PRI RATE	PRI VTBI	SEC RATE	SEC VTBI
999	1998	500	100
499	998	500	100
250	500	500	100
125	250	500	100
10	20	500	100

In each combination, the primary and secondary rates and VTBIs can be manually altered.

The device automatically stops one hour after the PRI START key was pressed. While the device is running, the air sensors and the upstream and downstream occlusion detectors are disabled.

### 5.3.4 Automatic Test Mode 4: Aging Mode

**Warning:** This is an automatic test mode for testing the device during manufacturing only. This mode must not be used on patients because the rates and VTBIs cannot be altered.

While the device is stopped, pressing any numbered key (0-6) programs a preset rate/VTBI combination as follows:

Key Number	PRI RATE	PRI VTBI	SEC RATE	SEC VTBI
0	500	3000	999	6000
1	499	0	999	1
2	3	0	0	0
3	250	0	0	0
4	499	100	0	0
5	1401	100	0	0
6	1999	100	0	0

The RATE/VTBI keys and number keys 7, 8, and 9 are not accepted. Other specifications are the same as during normal operation.

### 5.3.5 Automatic Test Mode 5: Display Check Mode

All the LCD segments, LEDs and icons turn on sequentially for a visual check each time the Pump 2 STOP key is pressed. At any point in the sequence the SEC START key may be pressed to return to the beginning of the sequence.

### 5.3.6 Automatic Test Mode 6: Time Information Display Mode

In this test mode, the cumulative time values are displayed sequentially each time the SEC RATE key is pressed. The test mode first displays the cumulative Power On time, then the time on battery, and finally, the time that each pump was actually pumping. It should be noted that the first six digits from the left are the time in hours and the two digits on the right are the time in minutes. Therefore, the display **0001 02:21** represents 102 hours and 21 minutes.

### 5.3.7 Automatic Test Mode 7: Pumping Sensor Monitoring Mode

**Warning:** This is an automatic test mode for testing the device during manufacturing only. This mode must not be used on patients.

In this test mode, the motor current and occlusion sensors may be monitored during pumping. During pumping, the motor current is displayed in the PRI VTBI location, the upstream occlusion detector reading in the SEC RATE location, and the downstream occlusion sensor reading in the SEC VTBI location. When the pump is stopped, all displayed values return to normal.

### 5.3.8 Automatic Test Mode 8: Air Sensor Test Mode

Upon entering this mode, the PRI RATE=30, PRI VTBI=100, SEC RATE=600, and SEC VTBI=100. Pressing the TIME key selects the device's air sensor sensitivity (**MIN** or **NORM**) without using the configuration option. The air sensor selection is displayed in the message dis-

---

play when a pump is started. All other keys function normally except for the TIME key. Rate and VTBI information for both primary and secondary mode may be changed.

### **5.3.9 Automatic Test Mode 9: Elapsed Time Test Mode**

The elapsed pumping time is displayed in the first line of the message display in this test mode. Momentarily pressing the TIME key selects two pre-programmed primary mode test conditions. The first is a PRI RATE of 125 mL/hr with a VTBI of 100 mL. The second is a PRI RATE of 499 mL/hr with a VTBI of 100 mL. The elapsed time counts only when a pump is running. Stopping a pump and then restarting it will reset the timer to zero. All keys except the TIME key work normally. When the VTBI has been delivered, the pump will enter KVO mode.

### **5.3.10 Automatic Test Mode 0: Downstream Occlusion Test Mode**

In this mode, pressing the TIME key will allow you to select the device's downstream occlusion level sensitivity without entering the configuration mode. The selected occlusion sensor level (1, 2, or 3) is momentarily shown in the second line of the message display until the test mode is exited. After exiting test mode, the downstream occlusion sensor level will revert back to the original configuration setting. Rate and VTBI information may be programmed manually.

### 5.4 Failure Identification Code Troubleshooting Table

Use Table 5-1 to determine the corrective action necessary to resolve failure codes. The causes of each failure code are listed in the order in which they are most likely to occur. Perform the corrective action items in the order in which they are listed and retest the device after each action. All replacement procedures are contained in Section 6.

There are two types of failure identification codes: Alarm (codes 1-19) and Failure (codes 20 and above). Alarm codes report malfunctions generally correctable by the operator. Failure codes may require servicing of the device. A code of 0 indicates that less than 10 alarms/failures have occurred since the log was cleared. The time and date will also be 0.

**Table 5-1. Failure Identification Codes**

CODE	CAUSE	CHECKS	CORRECTIVE ACTION
0	No alarms or failures.	No action necessary.	
1	Air bubble detected in a Run mode.	Check for air in tubing. Ensure set is correct type and is properly loaded. Ensure set tubing is not scratched or deformed.	Expel air in tubing. Replace or reposition set if tubing is flattened or scratched. Clean air sensor in accordance with Section 2 if dirty.
		Perform Section 5.3.2 steps 1 through 5.	If values are not within specification, recalibrate or replace the air sensor.
2	Downstream occlusion was detected: The sensor output increased by a specified value.	Check for scratched or deformed tubing. Verify that solution and ambient temperatures are between 60° and 100° F (15.5° and 37.7° C). Ensure set is correct type and is properly loaded. Check for spilled solution in sensor region.	Remove downstream occlusion and reposition the tubing. Clean occlusion sensors in accordance with Section 2 if dirty. Raise or lower temperatures if necessary.
		Perform Section 5.3.1, steps 1 through 6.	
3	Downstream occlusion was detected: The sensor output increased to an absolute value.	See Failure Identification Code 2.	



**Table 5-1. Failure Identification Codes**

CODE	CAUSE	CHECKS	CORRECTIVE ACTION
4	Upstream occlusion was detected: The sensor output decreased by a specified value.	Check for spilled solution in sensor region. Ensure set is proper type and is properly loaded.	Remove upstream occlusion and reposition tubing. Clean the sensor with cotton swabs dampened with one of the agents listed in Table 2-1. Remove fibers or foreign particles. <b>Do not use hard instruments for cleaning.</b>
		Ensure ambient and solution temperatures are between 60° and 100° F (15.5° and 37.7° C).	Raise or lower temperatures.
		Perform the steps in Section 5.3.1 related to upstream occlusion.	Reading displayed in the appropriate PRI RATE window must be between 3242 and 3314. If not, recalibrate or replace the sensor.
5	Upstream occlusion was detected: The sensor output decreased to an absolute value.	See Failure Identification Code 4.	
6	Low battery voltage (10.4 V or less) was detected.	If <b>BATTERY LOW</b> alarm is on and CHARGING LED is off, check: a. tightness of AC plug b. AC voltage source  c. power fuse d. battery fuse	a. Plug in firmly. b. If AC voltage is below 105 VAC, connect device to a correct voltage source. c. Replace if it has failed. d. Replace if it has failed.
		Turn device off and recharge for 8 hours.	If alarm recurs after recharging, check and repair loose connections at battery terminals. If problem persists, replace battery.
7	Communication alarm was detected: A framing error, overrun error or parity error occurred during the communication with an external computer.	Check that the device is in computer control mode. Check for the loss of the communications link. Verify that computer software is correctly loaded onto PC.	Place the device into computer control mode. Ensure communication cable is plugged in and/or the cable is wired correctly. Correct problems with PC software.

**Table 5-1. Failure Identification Codes**

CODE	CAUSE	CHECKS	CORRECTIVE ACTION
8	Communication time out alarm was detected: No communication between the device and an external PC for a given period.	See Failure Identification Code 7.	Place pump into computer control mode. Ensure communication cable is plugged in and/or the cable is wired correctly. Correct problems with PC software.
9	Slide Clamp Alarm (software versions 1.09 and later)	Slide clamp is not inserted or is improperly inserted in the slide clamp slot.	Insert slide clamp properly. Clean the slide clamp sensor with a cotton tipped swab dampened with water. If alarm recurs after cleaning the sensor, perform the slide clamp test in Section 7.
10	Misloaded tubing was detected.	Check set loading in the pump mechanism. Check any damage on the tube misloading sensors.	Load the tubing in the guides and channels correctly. Repair or replace the <i>FSR</i> *(s).
12	Upstream occlusion was detected in Revolution Counter Interrupt.	See Failure Identification Code 4.	
20	Malfunction in Door Open detection circuitry: P54 (Pump 1) or P55 (Pump 2) of the Master CPU remains low.	Check that magnet in pump door latch is present.	Replace pump door latch if magnet is missing. Repair or replace CPU board.
21	Malfunction in frequency converter circuitry for occlusion detection: P20 of Master CPU remains high.	Check CN851 (Pump 1) or CN852 (Pump 2) for proper connection and continuity.	Repair or replace connectors if necessary. Replace CPU board.
22	Malfunction in frequency converter circuitry for occlusion detection: P20 of Master CPU remains low.	See Failure Identification Code 21.	
23	P50 (IRQ interrupt port) remains high.	Check U101 pin 10 for a high (+5 VDC) signal.	If signal is always high, replace CPU board.
25	Failure in occlusion circuit.	None	Replace CPU board.

\* Interlink Electronics

**Table 5-1. Failure Identification Codes**

CODE	CAUSE	CHECKS	CORRECTIVE ACTION
27	Malfunction in slide clamp detection circuit.	Check battery voltage in accordance with section 5.3.1.  Check CN803 (Pump 1) or CN804 (Pump 2) for proper connection and continuity.	Clean contacts. Charge or replace battery. Repair or replace connector(s), if necessary. Replace safety/slide clamp assembly.
28	Four air sensors outputs (NORM and MIN of both pumps) cannot be selected.	Check CN811 (Pump 1) or CN812 (Pump 2) for proper connection and continuity.	Repair or replace connector(s) if necessary. Replace CPU board.
29	Two occlusion sensors (UP and DOWN) cannot be selected.	Check tightness of CN851 (Pump 1) or CN852 (Pump 2) for proper connection and continuity.	Repair or replace connector(s) if necessary. Replace CPU board.
30	Malfunction in A/D converter circuitry for air detection: A/D conversion did not complete in 50 $\mu$ S.	Turn device off and back on.	If failure recurs, replace CPU board.
31	Malfunction in air MIN detection circuitry: Input to A/D converter remains high.	Turn device off and back on.	If failure recurs, replace CPU board.
32	Malfunction in air NORM detection circuitry: Input to A/D converter remains high.	Turn device off and back on.	If failure recurs, replace CPU board.
33	Malfunction in air MIN detection circuitry: Input to A/D converter is not 0 V although the MIN air transducer is not oscillating.	Check tightness of CN811 (Pump 1) or CN812 (Pump 2) connectors on the CPU board.	Repair or replace connectors, if necessary. Replace CPU board.
34	Malfunction in air NORM detection circuitry: Input to A/D converter is not 0 V although the NORM air transducer is not oscillating.	Check tightness of CN811 (Pump 1) or CN812 (Pump 2) connectors on the CPU board.	Repair or replace connectors, if necessary. Replace CPU board.
35	Front panel key was pressed for more than 40 seconds.	Check that key was not inadvertently pressed for 40 seconds. Check that front panel is not damaged.	Turn the device off and back on. If failure code recurs, replace front panel.
36	Master CPU received an abnormal power ON/OFF signal.	Check HIC302 on CPU board for proper function.	Replace HIC302 or CPU board.

**Table 5-1. Failure Identification Codes**

CODE	CAUSE	CHECKS	CORRECTIVE ACTION
37	Either <b>ON-OFF/CHARGE</b> key was pressed for more than 5 seconds when device power was off.	Check that the keys were not inadvertently pressed for 5 seconds. Check that both keys are not damaged.	Replace front panel if necessary.
38	Malfunction in tube misloading detection circuitry.	Check CN803 (Pump 1) or CN804 (Pump 2) for proper connection.	Clean contacts on male connector. Repair or replace connector if necessary, or replace FSR*.
41	Abnormal operation of Master CPU.	Turn device off and back on.	If failure code recurs, replace CPU board.
42	Malfunction in alarm control circuit.	Turn device off and back on.	If failure recurs, replace CPU board.
46	The PWRON1 signal is held low.	Turn device off and back on.	If failure recurs, replace CPU board.
47	The PWRON1 signal is held high.	Turn device off and back on.	If failure recurs, replace CPU board.
48	Malfunction in real time clock: RTC does not count time correctly.	Turn device off and back on.	If failure recurs, replace U506 or CPU board.
49	Malfunction in real time clock: Abnormal RTC data.	Turn device off and back on. Check backup battery voltage in accordance with Section 5.3.1. Reset all configuration option settings in accordance with Section 1.5.2.	If failure recurs, charge or replace battery.  Replace U506 or CPU board.
50	Master CPU received a TRAP interrupt.	Turn device off and back on.	If failure recurs, replace the software (EPROMs). Replace CPU board.
51	Master CPU received a CMI interrupt.	Turn device off and back on.	If failure recurs, replace CPU board.
52	Master CPU received a SWI interrupt.	Turn device off and back on.	If failure recurs, replace CPU board.
53	Master CPU received a NMI interrupt.	Turn device off and back on.	If failure recurs, replace CPU board.
54	Master CPU received an OCI interrupt.	Turn device off and back on.	If failure recurs, replace CPU board.
55	Master CPU received an IRQ2 interrupt.	Turn device off and back on.	If failure recurs, replace CPU board.
58	Master CPU's TIMER 1 interrupt does not occur.	Turn device off and back on.	If failure recurs, replace CPU board.
59	Program stuck in block 1 routine.	Turn device off and back on.	If failure recurs, replace CPU board.

\*Interlink Electronics

**Table 5-1. Failure Identification Codes**

CODE	CAUSE	CHECKS	CORRECTIVE ACTION
60	Malfunction in battery voltage detection circuitry: Input to A/D converter remains high.	Turn device off and back on.	If failure recurs, replace CPU board.
61	Malfunction in battery voltage detection circuitry: Input to A/D converter remains low.	Turn device off and back on.	If failure recurs, replace CPU board.
62	Malfunction in memory backup battery voltage detection circuitry: Input to A/D converter remains high.	Turn device off and back on.	If failure recurs, replace CPU board.
63	Lithium backup battery voltage is too low to back up the memories.	Check connector CN304 for proper connection and continuity.	Plug CN304 in firmly. Replace lithium backup battery. Replace CPU board.
64	Malfunction in A/D converter circuitry: A/D conversion for 0 through 3 channels did not complete in 144 $\mu$ S.	Turn device off and back on.	If failure recurs, replace CPU board.
65	Malfunction in A/D converter circuitry: A/D conversion for 4 through 7 channels did not complete in 144 $\mu$ S.	Turn device off and back on.	If failure recurs, replace CPU board.
66	Supply voltage of CPU circuitry is too high.	Turn device off and back on.	If failure recurs, replace the CPU board.
67	Supply voltage of CPU circuitry is too low.	Turn device off and back on.	If failure recurs, replace the CPU board.
68	Malfunction in A/D converter circuitry: A/D conversion for channels 8 and 9 did not complete in 72 $\mu$ S.	Turn device off and back on.	If failure recurs, replace U501 or CPU board.
69	Abnormal battery recharging voltage.	Check calibration of DC Power Supply board.	Recalibrate the board. If failure recurs, replace U501 or CPU board.
70	Data in duplicate memory areas does not agree.	Turn device off and back on.	If failure recurs, replace CPU board.
71	Slave CPU received no data from Master CPU.	Turn device off and back on.	If failure recurs, replace CPU board.

**Table 5-1. Failure Identification Codes**

CODE	CAUSE	CHECKS	CORRECTIVE ACTION
72	Slave CPU received undefined data 4 times from Master CPU.	Turn device off and back on.	If failure recurs, replace CPU board.
73	Overcurrent to motor.	Check for loose motor coupler.  Check that CN201 (Pump 1) or CN202 (Pump 2) is seated firmly.	Apply a trace of Loctite* 211 or 222 to coupling set screws and tighten them to 5 kgf-cm (4.3 in-lb) Plug CN201 and CN202 in firmly. Replace CPU board.
74	Motor slipped even though at maximum current to motor.	Check CN201 (Pump 1) and CN202 (Pump 2) for proper connection and continuity.	Plug CN201 and CN202 in firmly. Check for blown fuse F201 (Pump 1) or F251 (Pump 2).
77	Slave CPU received no revolution interrupt while motor is rotating.	Turn device off and back on. Ensure that the encoder disk is properly secured. Check photointerrupter output for proper function.	Secure encoder disk.  Replace photointerrupters if necessary. Replace CPU board.
78	Drive defect - overinfusion. High motor rotation against the number of revolution counter interrupts.	See Failure Identification Code 77.	
79	Drive defect - underinfusion. Low motor rotation against the number of revolution counter interrupts.	Ensure that pump head is clean and rotates freely. Check coupling between pump mechanism and motor. Check encoder disk for secure mounting.	Apply a trace of Loctite* 211 or 222 to coupling set screws and tighten. Secure encoder disk. Replace CPU board.
82	No acknowledgment message from Slave CPU for three communication trials.	Turn device off and back on.	If failure recurs, replace CPU board.
83	Undefined message type received from Slave CPU.	Turn device off and back on.	If failure recurs, replace CPU board.
86	LVDT reading of downstream occlusion sensor is too high.	Check calibration of downstream occlusion sensors.	See Failure Identification Code 2.

\*Loctite, Inc.

**Table 5-1. Failure Identification Codes**

CODE	CAUSE	CHECKS	CORRECTIVE ACTION
87	LVDT reading of upstream occlusion sensor is too high.	Check calibration of upstream occlusion sensors.	See Failure Identification Code 4.
89	Bank switching control circuit failure.	Turn device off and back on.	If failure recurs, replace CPU board.
90	Checksum error of RATE, VTBI and VI data. Checksum is not 0.	Turn device off and back on.	If failure recurs, replace CPU board.
91	Checksum error of Programmed Delivery Profile stored data.	Reset all of PDP.	If failure recurs, replace CPU board.
92	Checksum error of Programmed Delivery Profile working data.	Reset all of PDP.	If failure recurs, replace CPU board.
93	Write data and read data of M5M5165 do not agree.	Turn device off and back on.	If failure recurs, replace CPU board.
94	Configuration option settings checksum is not 0.	Reset all of the configuration option settings in accordance with Section 1. Turn device off and back on. Check battery voltage in accordance with Section 5.3.1.	If failure recurs, charge or replace battery.  Replace CPU board.
95	Checksum error of alarm log data.	Turn device off and back on. Clear the alarm log via the modify configuration mode.	If failure recurs, replace CPU board.
96	Checksum error of ROM code.	Turn device off and back on.	If failure recurs, replace CPU board.
99	Undefined failure code was received from Slave CPU.	Turn device off and back on.	If failure recurs, replace CPU board.

## 5.5 Troubleshooting Chart

Table 5-2 identifies specific failures by symptoms rather than failure identification codes.

Table 5-2. Troubleshooting Chart		
SYMPTOM	CHECKS	CORRECTIVE ACTION
One or both pumps cannot be turned on.	Check backup battery voltage in accordance with Section 5.3.1. Check front panel cables for short circuits. Check CN601 and CN602 for proper connection and continuity.	Sometimes this condition is followed by an F49 or F94 code. Charge or replace battery. Repair if necessary.
One or both pumps cannot be turned off.	Check front panel cables for short circuits. Check CN601 and CN602 for proper connection and continuity.	Replace front panel film.  Replace CPU board.
All front panel keys other than <b>BACKLIGHT</b> and <b>TOT VOL/STATUS</b> are disabled.	Does <b>Loc</b> appear in the Main Display?	Press and release <b>PANEL LOCK</b> switch on the rear panel. <b>Loc</b> in the Main Display should disappear.
One or more front panel keys are not accepted.	Turn device off and back on and try the key again. Check front panel cables for proper connection and continuity.	Replace front panel film.  Replace Display board.
<b>PANEL LOCK</b> switch is not accepted.	Check the operation of the switch. Check CN701 and CNI/F for proper connection and continuity.	Replace <b>PANEL LOCK</b> switch.
Beep does not sound when a key other than <b>BACKLIGHT</b> or <b>SILENCE</b> is pressed when the pump is stopped.	Turn the device off and back on. Check CN751, CN701, and CNI/F for proper connection and continuity.	If problem recurs, replace CPU board. Repair or replace the connectors. Replace speaker.
The device does not run on AC but runs on internal battery.	Check CNAC and CN301 for proper connection and continuity. Check that the AC power cord is firmly connected.	Repair or replace the connectors if necessary. Replace CPU board. Repair or replace power cord.
The Battery Icon is lit while the device is running on AC.	Check AC fuse.  Check connectors CNAC and CN301 for proper connection and continuity.	Replace AC fuse(s) with same type and rating if it has failed. Replace CPU board.



**Table 5-2. Troubleshooting Chart**

SYMPTOM	CHECKS	CORRECTIVE ACTION
The Battery Icon is off while the device is running on internal battery.	Turn device off and back on.	If failure recurs, Replace Display board. Replace CPU board.
The LCDs are blank, have missing segments, or indicate an irrational display.	Check ICP301 and CNDISP for proper connection and continuity using Test Mode 5 (Section 5.3.5).	Install LCD Cushions, if necessary. See Section 6.3.28. Replace CPU board. Replace Display board. Replace Sensor Board
The backlight does not light.		Replace Display board.
The backlight cannot be turned off.		Replace Display board. Replace CPU board.
The device or a pump turns off or stops with audible alarm for no apparent reason.	Check ICP301. Check CN601 and CN602 for proper connection and continuity. Check front panel cables for short circuits.	Replace ICP301. Repair or replace connectors if necessary.  Replace front panel film.  Replace Display board.
ALARM LED(s) is (are) always lit.	Turn device off and back on.	If problem recurs, charge or replace battery. Replace CPU board. Replace Display board.
ALARM LED does not light.	Check CNDISP for proper connection and continuity.	Replace CPU board. Replace Display board.
ALERT LED is always lit.	Turn device off and back on. Check CNDISP for proper connection and continuity.	If problem recurs, charge or replace battery. Replace CPU board. Replace Display board.
ALERT LED does not light.	Check CNDISP for proper connection and continuity.	Replace CPU board. Replace Display board.
ALARM and ALERT LEDs are lit, but the pump will not operate.	Check backup battery voltage in accordance with Section 5.3.1.	Sometimes this condition is followed by a F49 and/or F94 code. Recharge or replace the battery to clear the condition.
PUMPING LED(s) is always lit.	Check CNDISP for proper connection and continuity.	Replace Display board.
PUMPING LED(s) does not light.	Check CNDISP for proper connection and continuity.	Replace Display board.
Audible alarm is always on.	Momentarily disconnect battery and reconnect. Check F302 or F15 (ICP301). Check CN302, CN&01, CN751, and CNI/F for proper connection and continuity.	Charge or replace battery. Replace F302, F15, and/or connectors as required. Replace CPU board.

**Table 5-2. Troubleshooting Chart**

SYMPTOM	CHECKS	CORRECTIVE ACTION
Audible alarm does not sound.	Turn device off and back on.	If problem recurs, replace CPU board. Replace speaker.
<b>DOOR OPEN</b> alarm occurs while door is closed, or does not occur when door is opened.	Check magnet on door latch. Check CN851 (Pump 1) or CN852 (Pump 2) for proper connection and continuity.	Replace pump door latch if magnet is missing. Repair or replace connector if necessary. Replace CPU board.
Optional nurse call is always on.	Check CN401 and CNI/F for proper connection and continuity.	Replace CPU board.
Optional nurse call is always off.	Verify that the Nurse Call feature has been enabled via the addition of a jumper (R421) on the terminal PCB. Check CN401, and CNI/F for proper connection and continuity.	Replace CPU board.
Pump operation is louder than normal.	Check administration set for proper type and code. Check for solution spills on the pumping fingers and around the back plate. Check the tightness of the motor mounting bracket screws. Check for a PC board or other assembly vibrating against the inside of the case.	Replace with Baxter's "s" suffix administration set if required. Clean in accordance with Section 2.  Tighten, as required.  Ensure all internal assemblies are securely fastened.
The rear clamp fails to hold the device on the IV pole.	Check for worn or missing friction pad. Check the clamp for worn threads and other worn or defective parts.	Replace worn or defective parts on the clamp as necessary.
Free flow occurs when the door is closed.	Check administration set for proper type and code. Check position and seating of the tubing. Check that ambient and solution temperatures are between 60° and 100° F (15.5° and 37.7° C). Check for cracks in the door hinges. Check for deformation of the coil springs of the back plate. Check for worn cams and pumping fingers. Check for damaged or deformed door latch.	Replace with Baxter's "s" suffix administration set if required. Position tubing properly, without stretching or slack. Raise or lower the temperatures.  Replace the pump head in accordance with Section 6.3.8. Replace the springs, if required.  Replace worn parts, as required. Replace door latch in accordance with Section 6.3.5.

**Table 5-2. Troubleshooting Chart**

SYMPTOM	CHECKS	CORRECTIVE ACTION
<p>Free flow occurs when the door is opened.</p>	<p>Check administration set for proper type and code.                      Check for solution spills on and around safety clamp.                      Check position and seating of tubing in safety clamp.</p> <p>Check that ambient and solution temperatures are between 60° and 100°F (15.5° and 37.7°C).                      Check for broken safety clamp spring and/or broken safety clamp.</p>	<p>Replace with Baxter's "s" suffix administration set if required.                      Clean in accordance with Section 2.2.                      Position tubing properly and make certain it is seated in guides and channels.                      Raise or lower the temperatures.</p> <p>Replace broken parts, if required.</p>
<p>Backup buzzer does not activate during self test.</p>	<p>Check that the buzzer wiring is connected.                      Check for an open fuse on the battery wire harness.</p>	<p>Plug in connector.                      Replace fuse.                      Replace backup buzzer.</p>
<p><b>INSERT SLIDE CLAMP</b> alert or alarm is constantly on.  <b>Note: The alarm option is only available on pumps running software versions 1.9 or later.</b></p>	<p>Ensure that the slide clamp sensor is clean.                      Check connections.                      Check calibration and operation.</p>	<p>Clean the slide clamp sensor.                      Disconnect and reconnect.                      Perform steps in Section 6.4.5.</p> <p>Replace the safety/slide clamp assembly.</p>



# Section 6

---

## Disassembly and Calibration

### 6.1 Introduction

This section of the manual includes a list of tools and test equipment required for performing maintenance, procedures for removing and replacing subassemblies once the cause of a malfunction has been determined, and procedures for calibration after component or circuit board replacement. Detailed exploded views of the device are provided in Section 8.

### 6.2 Preparation for Maintenance

#### 6.2.1 Tools and Test Equipment

The following tools and test equipment are required to perform the procedures contained in this section. **Since all fasteners on this device are metric, ensure that all tools used are for metric fasteners. Tightening torques on certain screws are specified in kgf-cm and in-lb for your convenience. The values in in-lb are approximate.**

**Note:**      **Reset the configuration options in accordance with Section 1.5.2 after performing any repairs. This is especially important after replacing the EPROMs, and after the occurrence of failure codes 49 or 94.**

Test Equipment	Tools
Digital Voltmeter	Razor blade
DC Ammeter	Metric Phillips-head screwdriver, #0
5 ohm, 20W resistor with variable load (See Figure 6-4)	Metric Phillips-head screwdriver, #1
Thickness gauge, part number UKOG1013.B	Metric Phillips-head screwdriver, #2
0.3 mm, flat-feeler gauge	UPP extractor, part no. UKOG1020.A
Grounded wriststrap	Wire harness connector extractor, part no. UKOG1021.A
Anti-static mat or other anti-static work surface	Slide Clamp Resetting Tool, part no. 020416132
Calibration tubing, part no. 3-2-92-479	Torque screwdriver, 0-15 kgf-cm or 0-20 in-lb
Precision 0.1 $\mu$ L gas-tight syringe, part no. S9662-81 (or equivalent)	Metric ball point Allen wrench, 1.5 mm
Precision 250 $\mu$ L gas-tight syringe, part no. S9662-82 (or equivalent)	Soldering Iron, temperature-regulated, 600° - 700°F, 20 - 48 Watts, 1/32" tip
Oscilloscope (dual trace)	

### 6.2.2 Recording the Configuration Option Settings

It is necessary to record the configuration option settings and the alarm log data before beginning maintenance procedures so that the device can be reconfigured properly when maintenance is completed.

**Note:** When the battery, EPROMs or a circuit board is disconnected or replaced, or a calibration is performed, all the configuration options must be reset. See Section 1.5.2.

1. Turn on Pump 2. Enter the configuration review mode by pressing the TIME and TOT VOL/STATUS keys simultaneously. Hold the keys for 1 second.
2. Press the NEXT or SEC START key to access each parameter sequentially. Record the configuration settings.
3. Exit the configuration inspection mode by pressing TIME and TOT VOL/STATUS again or press the Pump 2 STOP key.

4. Record the contents of the alarm log by pressing the SILENCE and TOT VOL/STATUS keys simultaneously while both pumps are on. Within one second, press the CLEAR TOT VOL key to bring up the rest of the failure codes for each pump.

### 6.3 Disassembly/Reassembly

Disassembly of the Flo-Gard® 6301 Dual Channel Volumetric Infusion Pump is limited to the mechanical components and printed circuit boards (PCBs). It is recommended that electrical problems be corrected by replacing entire PCBs unless circumstances warrant component repair. Use only approved replacement parts provided by Baxter Healthcare Corporation and listed in Section 8.

Please read all steps in the procedure before beginning. The procedures are given in order of disassembly. Disassemble the device only as far as required to complete repair. **All fastening components such as screws, washers and nuts used in the device are metric. Be sure to use metric tools and replace only with metric components.**

**Caution:** The device is sensitive to electrostatic discharge damage (ESD). Always wear a grounded wriststrap when performing maintenance on the device to prevent damage to components.

**Warning:** Always make sure that the device is unplugged and that both pumps are turned off before disassembling. Failure to do so can result in personal injury and/or damage to the device.

#### 6.3.1 Separation of Front and Rear Housings

1. Turn the device off and place it face down on an anti-static mat or work surface. Take care not to lay the device face down on components (such as screws) which could damage the front panel.
2. Remove 10 screws that secure the rear housing to the front housing. (Figure 8-4, items 10 and 60.)

**Caution:** Avoid stressing the device's internal cabling when separating the front and rear housings.

3. Stand the device upright and separate the front and rear housings by slowly pulling the front half forward by about 10.16 cm (4").
4. While the device is standing, disconnect CN301 and CN302 from the CPU board (Figure 8-2, item 3). The connectors are located in the center at the top, in the front half of the device.

**Note:** The backup audible alarm may be activated. Continue with step 5 to disable the alarm.

5. Lay the front case half down on its front surface. Position it immediately in front of the rear half. Disconnect the following to completely separate the two housings:
  - a. CN751 from the back up audible alarm board (Figure 8-3, item 3) located at the top left of the rear housing to disable the back up audible alarm during the disassembly.

**Note:** Be sure to unlock the connector flange by pulling it forward about 2mm (3/4") before disconnecting the cable.

- b. Disconnect the flat cable connector (CNI/F) from the CPU board.
  - c. Disconnect CN1 from the power supply board.
  - d. Disconnect the ground wire from the pump head mounting plate for Pump 2 (Figure 8-2, item 7).
6. Reassemble the housings in the following order:
  - a. Connect the ground wire to the pump head mounting plate for Pump 2.
  - b. Make sure that the connector flange is unlocked and reconnect the flat cable connector CNI/F on the CPU board. Push in the flange to hold the ribbon cable in place.
  - c. Replace CN1 on the power supply board.
  - d. Replace CN751 on the backup audible alarm board located in the rear housing. Connect CN302 on the CPU PCB. If the audible alarm is activated, press both ON-OFF/CHARGE keys.
  - e. Route the pump head harness and pump head ground wire in the front housing referring to Figure 8-2 so that they will not be pinched by internal components when the housings are closed.
  - f. Stand the front housing up.
  - g. Route the battery harness along the side of the battery compartment so that it is not pinched by the power transformer.



- h. Route the flat cable so that it is not located above the pump head.
- i. Route the ground wire above the stepper motor.

**Note:** Be sure to make the orientation of the crimped terminals of the ground wire at the grounding plates as shown in Figure 8-2, item 14 and Figure 8-3, item 21.

- j. Reconnect CN301 and close the two housings by slightly lifting and moving the rear housing slowly toward the front housing.

**Caution:** Do not pinch the ground wire between the housings.

- k. Plug power cord into an AC outlet and check that the Plug Icon is lit. If not, check for proper connection of CN301.
- l. Press an ON-OFF/CHARGE key and check that the self test is performed correctly. If the back up audible alarm sound is not heard, check for proper connection of CN751.
- m. Unplug the power cord and check that the Battery Icon is lit. If not, check for proper connection of CN302.
- n. Be sure the front and rear housing surfaces are flush before tightening. Replace 8 screws (Figure 8-4, item 10) and tighten them to 9 kgf-cm (7.8 in-lb) with a torque screwdriver.
- o. Replace 2 screws (Figure 8-4, item 60) at handle. Tighten them to 9 kgf-cm (7.8 in-lb) with a torque screwdriver.
- p. Perform the Operational Checkout procedure in Section 7 if no other repairs are performed.

### 6.3.2 Separation of Printed Circuit Boards

1. Separate the front and rear housings completely except for the ground wire (Section 6.3.1).
2. Disconnect the two connectors (CN601 and CN602) of the front panel film (Figure 8-1, item 4) from the CPU board (Figure 8-2, item 3).

3. Disconnect the following pump head connectors (Figure 8-17, Sheet 1) from the CPU board with the wire harness connector extractor, part no. UKOG1021.A:  
Pump 1: CN201, CN803 (right side) and CN851, CN811 (left side)  
Pump 2: CN202, CN852, CN812 and CN804 (left side)
4. Remove the six screws (Figure 8-2, item 16) that hold the CPU board in the front housing.
5. Hold the top and bottom center of the CPU board and remove the printed circuit boards carefully from the front housing.

**Note:** If resistance is felt, the top portion of the printed circuit boards may be affixed to the front housing by the adhesive of the seal around the LCDs. Incline the bottom center of the CPU board until the seal comes off the front housing before the removal.

6. Place the printed circuit boards with the LCD display face down on a dust free flat surface. Be careful not to touch or damage the LCD display. Keep the LCD display surface away from dust. Take care not to place the LCD display on components (such as screws) that could damage it.
7. Reassemble in reverse order.

**Note:** Be sure to remove any dirt or dust on the LCD or its windows on the front housing before replacing and tightening the CPU board to the front housing.

**Placing the one side of the CPU board under the two connectors, CN601 and CN602, first simplifies the replacement of the board. Do not pinch the pump head harness and the grounding wire between the pump head fixing brackets (Figure 8-2, items 6 and 7).**

**Be sure to reconnect all the removed connectors. Tighten the six screws (Figure 8-2, item 16) securing the CPU board to 7 kgf-cm (6.1 in-lb).**

8. Perform the Operational Checkout procedure in Section 7.

### 6.3.3 Replacement of Front Panel Film

1. Separate the front and rear housings completely except the ground wire (Section 6.3.1).
2. Separate the printed circuit boards (Section 6.3.2).
3. Remove one screw (Figure 8-2, item 13) that grounds the front panel film.

**Caution: Do not damage the front housing or the EMI plating with the tool. Do not reuse the removed front panel.**

4. Remove the front panel film and the silicon rubber around the panel from the front housing with a razor blade or similar tool.
5. Reassemble in reverse order. Remove the adhesive backing from the new front panel film and apply it, pressing firmly around the film edges to ensure that the film is securely attached to the device with no gaps. Tighten the front panel film grounding screw (item 13) to 3 kgf-cm (2.6 in-lb).
6. Perform the Operational Checkout procedure in Section 7.
7. Seal the edges of the new front panel as follows:
  - a. Place the device on its back and apply a strip of masking tape along the four edges and corners of the front panel, approximately .38 to .64 mm (0.015 to 0.025") from the edges and corners of the panel.
  - b. Using a dispenser with a small-diameter tip, apply a bead of Toray Dow\* Silicone SE 9189 L (part no. UPAS0002.A) along the edges and corners of the panel. Apply the bead uniformly, within 40 to 50 seconds per edge.
  - c. Remove the masking tape before the silicone starts to form a skin.
  - d. Keep the device on its back for 30 - 45 minutes.

### 6.3.4 Replacement of Pump Door Cover

1. Open the pump head door.
2. Remove five screws that secure the pump door cover to the pump door (Figure 8-1, item 13). Do not remove the screw affixing the metal plate in the recess at the bottom of the door (Figures 8-5 and 8-10, item 27).

\*Toray-Dow Corning

3. Reassemble the cover in reverse order. Tighten each of the five screws to 4 kgf-cm (3.5 in-lb) with a torque screwdriver.

### **6.3.5 Replacement of Pump Door Latch**

1. Remove the pump door cover in accordance with Section 6.3.4.
2. Close the pump door.
3. Remove the E-ring (Figures 8-5 or 8-10, item 5) that secures the door latch.
4. Lift the door latch and carefully pull it out of the pump door. **Use caution to avoid losing the associated parts on the door latch pin.**
5. To replace the latch, lay the device on its back.
6. Place one thin washer (Figure 8-5 or 8-10, item 8), the spring (item 6), and the other thin washer (item 8) on the door latch pin.
7. Insert the pin into the hole in the pump door.
8. Open the pump door slightly.
9. Press the door latch in toward the pump door so that the spring is compressed.
10. Install 4 mm washer (item 7) on the pin.
11. Install the E-ring (item 5) on the pin.
12. Calibrate in accordance with Sections 6.4.2 through 6.4.4.
13. Perform the Operational Checkout procedure in Section 7.

### **6.3.6 Replacement of Pump Door or Pump Door Assembly**

1. Remove the door cover in accordance with Section 6.3.4.
2. Remove the two set screws (Figure 8-5, item 29).
3. Slide the hinge pins (item 14) toward each other and remove the door.

4. Install the replacement door assembly in reverse order. Note the alignment of the hinge pins and make sure that the tapered ends are pointed toward each other.
5. Calibrate the air sensor in accordance with Section 6.4.1 through 6.4.4.
6. Perform the Operational Checkout procedures in Section 7.

### 6.3.7 Replacement of Door Latch Pin

1. Remove one screw (Figure 8-6 or 8-11, item 17) that secures the latch pin mounting block to the pump head base plate.
2. Install replacement door latch pin and secure with 1 screw.
3. Calibrate in accordance with Sections 6.4.1 through 6.4.4.
4. Perform the Operational Checkout procedures in Section 7.

### 6.3.8 Replacement of Pump Head Assembly

1. Separate the front and rear housings completely (Section 6.3.1).
2. Disconnect the following pump head connectors (Figure 8-17, Sheet 1) from the CPU board (Figure 8-2, item 3) with the wire harness connector extractor, part no. UKOG1021.A:
  - Pump 1: CN201, CN803 (right side) and CN851, CN811 (left side)
  - Pump 2: CN202, CN852, CN812 and CN804 (left side)
3. Remove the screw that secures the pump head ground wires (Figure 8-2, item 14) to the pump head mounting plate (item 6 or 7).
4. Remove the pump door cover (Section 6.3.4).
5. Open the pump door and remove one black flat head screw and Phillips screw at the top and bottom of the pump head assembly (Figure 8-1, items 6 and 7).
6. Close the door and remove two black flat head screws (Figure 8-1, item 7) on the door hinge side that secure the pump head assembly to the front housing. These screws are accessible only when the door is closed. **Do not open the door before removing the two screws from the pump head assembly.**

7. Push the pump head assembly from the back and take it out of the front housing.

**Caution:** Do not pull out the two flexible cables (Figures 8-6 and 8-11, items 10 and 11) from their associated connector housings. This action could open the circuit.

Do not remove the gasket (Figure 8-1 item 5).

If resistance is felt, check for pinched wires between the pump head assembly and the mounting plate or remove tangled wiring harness.

Do not force the assembly out. Insulation of pump head wire harness can be damaged.

8. Reassemble the pump head assembly in reverse order.

**Caution:** Be sure not to pinch wires and gasket between the front housing and the pump head assembly when reinstalling the pump head assembly.

The three black screws (Figure 8-1, item 7) and one Phillips screw (item 6) must be torqued to 9 kgf-cm (7.8 in-lb). The screw (Figure 8-2, item 14) for the two grounding wires must be torqued to 7 kgf-cm (6.1 in-lb).

Route the pump head wiring harnesses as close as possible to the side of the pump head assembly so that wires are not pinched or damaged by internal components when the housings are closed.

9. Calibrate in accordance with Sections 6.4.1 through 6.4.4.
10. Perform the Operational Checkout procedures in Section 7.

### 6.3.9 Replacement of Upstream Occlusion Sensor

1. Remove two Phillips screws (Figure 8-7 or 8-12, item 16) which secure the sensor (item 9) to the pump head base plate.
2. Pull and rotate the sensor 45° clockwise and remove it from the pump head base plate.

**Caution:** Do not scratch the ribbon connectors located above the sensor. Scratches can damage the connectors.

3. Desolder black and white wires from sensor. Use caution to avoid contacting any plastic parts with the soldering iron.

4. Remove the screw (Figure 8-7 or 8-12, item 6) securing grounding plate (item 11), grounding wire and star washer (item 8). **Do not lose the plate, washer and screw.**
5. Install replacement sensor and reassemble in reverse order. **Be sure to attach the grounding wire and plate to the sensor (See Figure 8-7 or 8-12).** Tightening torque for item 16 is 3 kgf-cm (2.6 in-lb). Tightening torque for item 6 is 1.5 kgf-cm (1.3 in-lb).
6. Calibrate in accordance with Section 6.4.1 and 6.4.4.
7. Perform the Operational Checkout procedures in Section 7.

### 6.3.10 Replacement of Downstream Occlusion Sensor Assembly

1. Remove two Phillips screws (Figure 8-7 or 8-12, item 16) which secure the sensor to the pump head base plate.
2. Pull and rotate the sensor 45° clockwise and take it out of the pump head base plate.
3. Desolder the black and white wires from sensor. **Use caution to avoid contacting any plastic parts with the soldering iron.**
4. Remove the screw (Figure 8-7 or 8-12, item 6), grounding wire, and star washer (item 8). **Do not lose the washer and screw.**
5. Install replacement sensor and reassemble in reverse order. Tightening torque for item 16 is 3 kgf-cm (2.6 in-lb). Tightening torque for item 6 is 1.5 kgf-cm (1.3 in-lb).
6. Calibrate in accordance with Section 6.4.1 and 6.4.3.
7. Perform the Operational Checkout procedures in Section 7.

### 6.3.11 Installation of Air Sensor Assembly

**Caution:** The pump should be unplugged with the power turned off before beginning this procedure.

1. Remove ten screws from the back of the pump and carefully separate the case halves in accordance with Section 6.3.1, if necessary. Install a new air sensor assembly if it has not been replaced.

2. Separate connector CN811 for PUMP 1 and/or CN812 for PUMP 2 (middle left of the CPU board as viewed from the rear). Carefully lift and remove the pump head wire assemblies from PUMP 2 if they are routed between the hybrid circuits, HIC301 and HIC302.

**Note:**      **Note the location of the wire ties restraining the cable leading to CN811 and/or CN812 (for later replacement) and carefully cut and remove them.**

**Be sure not to cut or nick any other wires during this process. Removing one cable tie usually frees the cable but, in some instances, more will need to be removed. They will be replaced with new wire ties upon completion of these steps.**

3. Disconnect the air sensor connector(s) CN811 and/or CN812 from the CPU board. Remove the screws that secure the air sensor to the pump head and carefully pull out the air sensor assembly. Desolder the green ground wire from the back of the air sensor.
4. Desolder and discard the green ground wire from the back of the new air sensor assembly (Part no. S048992 for Pump 1 or S048993 for Pump 2) if it is present.
5. Be careful not to disconnect the ribbon cable of the slide clamp mechanism during this step. Insert the new air sensor connector through the air sensor opening on the pump head and pull the wires all the way through. Solder the ground wire to the new air sensor.
6. Secure the new air sensor to the pump head (tightening torque of 3 kgf-cm or 2.6 in-lbs) and reconnect CN811. This connector is keyed and will only mate in the correct orientation. Route the wires to their original locations and replace any cable ties removed. The number of ties and their locations should approximate the original configuration. Trim the ends of all newly added cable ties so that they are flush with the cable tie buckles.
7. Perform the calibration in Section 6.4.1 and 6.4.2.
8. Perform the Operational Checkout procedures in Section 7.

### **6.3.12 Replacement of Force Sensing Resistor\* (FSR\*\*) Devices for Tube Misloading Sensors**

1. Remove pump door cover in accordance with Section 6.3.4.
2. Separate the front and rear housings completely (Section 6.3.1).

\* Interlink Electronics

\*\* Interlink Electronics



3. Disconnect the tube misloading sensors (Figure 8-6 or 8-11, items 10 and 11) from the connector at rear top of the pump head assembly by pulling their connector housings. **Do not remove them by pulling the film.**
4. Open the pump door.
5. Remove two Phillips screws (Figure 8-7 or 8-12, item 16) which secure the upstream occlusion sensor (Figure 8-7 or 8-12, item 9) to the pump head base plate.

**Caution:** Do not scratch the ribbon connectors located above the sensors. Scratches can damage the connectors.

6. Pull and rotate the sensor 45° clockwise and take it out of the pump head base plate.
7. If the left *FSR\** for the pump will be replaced, remove the screw (Figure 8-6, item 17) holding the latch pin mounting block. If the right *FSR\** will be replaced, remove the screw (Figure 8-11, item 17) holding the latch pin mounting block for Pump 2.

**Caution:** Do not damage the base plate or the surface of the other tube misloading detector with the tool. Do not reuse the removed tube misloading detector.

8. Remove the tube misloading sensor from the pump head base plate with a razor blade or similar tool.

**Note:** All adhesive residues must be removed from the surface to ensure the successful attachment of the *FSRs\**.

9. Completely remove any adhesive residue from the base plate and clean the surface with an alcohol-soaked cloth.
10. Using a digital multimeter, check that the resistance of the replacement tube misloading sensor is between 140 K $\Omega$  and 210 K $\Omega$ . If it is not, do not use it.
11. Loosely attach a new tube misloading sensor to the pump head base plate. Ensure that it fits within its recess and does not override the pump head area. **Do not attach the sensor firmly to the pump head base plate yet.**
12. Check that the resistance of the tube misloading sensor is between 140 K $\Omega$  and 210 K $\Omega$ . If not, repeat steps 8 through 12.
13. If the sensor resistance reading is normal, press the tube misloading sensor firmly and ensure that it is securely attached to the pump head base plate with no gaps.

\*Interlink Electronics

14. Connect both sensors to the connectors at top rear of the pump head base plate through the hole for the upstream occlusion sensor (See Figure 8-6 or 8-11).
15. Replace the upstream occlusion sensor on the pump head base plate and perform the calibration checks in accordance with Section 6.4.1 and 6.4.4.
16. Install the mounting block for the latch pin by replacing one screw (Figure 8-6 or 8-11, item 17).
17. Reassemble the case halves.
18. Perform the Operational Checkout procedures in Section 7.

### 6.3.13 Replacement of Pump Motor

1. Remove pump door cover in accordance with Section 6.3.4.
2. Separate the front and rear housings completely (Section 6.3.1).
3. Remove pump head assembly in accordance with Section 6.3.8.
4. Close the pump door.
5. Carefully place the pump head assembly face down on the work surface.
6. Carefully remove the two springs (Figure 8-8 or 8-13, item 9) above the motor coupling. **Perform this step carefully to avoid losing springs.**
7. Remove two screws that secure the motor holding plate to the safety/slide clamp assembly (Figure 8-9 or 8-14, item 30).
8. Remove two screws, washers and spring washers (Figure 8-8 or 8-13, items 22, 14 and 25) securing the encoder cover (Figure 8-8, item 16) and finger box cover to the finger box. **Do not lose the short nut bar (Figure 8-8, item 31).**
9. Remove two screws, washers and spring washers (Figure 8-8, items 22, 14 and 25) securing the finger box cover to the finger box above the motor coupling. **Do not lose the long nut bar (item 32).**
10. Remove the finger box cover.

**Note:** Slide the encoder cover toward the encoder to prevent it from sticking to the encoder screw head.

11. Carefully lift and remove the motor and its associated assembly from the pump head base plate. **Take care not to deform the encoder or damage the fingers. Keep the finger box and the fingers away from dirt or dust.**
12. Remove the motor holding plate (Figure 8-9 or 8-14, item 8) from the motor shaft bottom and carefully place on the work surface.
13. Remove two set screws (Figure 8-8 or 8-13, item 27) closest to the motor.
14. To install the motor, push motor shaft into motor coupling (item 8). Install set screws (item 27). **Do not tighten them at this time.** Attach the spring retainer (item 2) to the replacement motor, as necessary.
15. Place the motor holding plate (Figure 8-9 or 8-14, item 8) onto the motor shaft bottom such that the plate protrudes from the motor housing on the side with the wires (Figure 8-8 or 8-13).
16. Install the motor and the assembly into the pump head base plate ensuring that:
  - a. The motor is positioned such that the wires go out the back of the base plate (Figure 8-8 or 8-13).
  - b. The fingers are in the finger box and the motor holding plate is properly installed in the hole on top of the safety/slide clamp assembly (item 1).
17. Check that the bearings (item 10) are properly seated on the finger box and install the finger box cover using the four screws, washers and spring washers (items 22, 14 and 25). Before tightening these screws, rotate the motor coupling by hand to ensure smooth rotation of the motor shaft and the encoder. Tighten the screws to 6 kgf-cm (5.2 in-lb).
18. Install the motor holding plate onto the safety/slide clamp assembly. Tighten the two screws (Figure 8-9 or 8-14, item 30) to 6 kgf-cm (5.2 in-lb).
19. Apply a trace of Loctite\* 211 or 222 to the set screws (Figure 8-8 or 8-13, item 27).
20. Place a 0.3 mm, flat-feeler gauge between the motor bottom surface and the motor holding plate. Ensure that the edge of the flat-feeler gauge is touching the motor shaft. Press the motor against the plate and tighten the set screws to 5 kgf-cm (4.3 in-lb).

\*Loctite, Inc.

**Note:** When the set screws have been properly tightened, the screw heads will be recessed in the motor coupling and the screw ends will be in contact with the flat surfaces of the finger shaft.

21. Install the springs removed in step 6.
22. Install pump head assembly into case in accordance with Section 6.3.8.
23. Perform the Operational Checkout procedures in Section 7.

### **6.3.14 Replacement of Safety/Slide Clamp Assembly**

1. Remove pump door cover in accordance with Section 6.3.4.
2. Separate the front and rear housings in accordance with Section 6.3.1.
3. Remove pump motor in accordance with Section 6.3.13.
4. Press the safety clamp pin (Figure 8-9 or 8-14, item 6) to close the safety clamp. Remove the screw (Figure 8-7 or 8-12, item 2) on the right side of the safety clamp arm cover (item 10) and remove the arm cover. Close the pump door.
5. Place the pump head face down and remove the two screws (Figure 8-9 or 8-14, item 35) to remove the sensor assembly.
6. Remove the two screws (Figure 8-9 or 8-14, item 30) on the bottom of the safety/slide clamp assembly to release the motor holding plate (item 8).
7. Remove the six screws (Figure 8-8 or 8-13, item 60) on the finger box and lift the finger and motor assembly off of the base plate.
8. Remove the flexible cable at the back of the safety/slide clamp assembly from the connector on the terminal board. **Be sure to pull the white part so as not to damage the flexible cable.**
9. Remove four screws (Figure 8-8 or 8-13, items 28 and 55) securing the safety/slide clamp assembly and remove it from the pump head base plate.

10. Press the safety clamp pin (Figure 8-9 or 8-14, item 6) to close the safety clamp, install replacement safety/slide clamp assembly into rear of the pump head base plate and secure with four screws (Figure 8-8 or 8-13, items 28 and 55). **Make sure safety clamp seal (Figure 8-9 or 8-14, item 25) is in place.** Tightening torque for the four screws is 6 kgf-cm (5.2 in-lb).
11. Connect the flexible cable (Figure 8-9 or 8-14, item 29) to the connector in the terminal board.
12. Install the finger and motor assembly with the motor holding plate using the six screws (Figure 8-8 or 8-13, item 60). Tightening torque is 6 kgf-cm (5.2 in-lb).
13. Install the two motor holding plate screws (Figure 8-9 or 8-14, item 30). Tightening torque is 4 kgf-cm (3.5 in-lb).
14. Place a 0.3mm, flat-feeler gauge between the motor bottom surface and the motor end plate. If the flat-feeler gauge cannot be inserted or the gap is wider than .3mm, loosen the set screws (Figure 8-8 or 8-13, item 27) to move the motor. Ensure that the edge of the flat-feeler gauge is touching the side of the motor shaft. Press the motor against the plate and tighten the set screws to 5kgf-cm (4.3 in-lb).
15. Install the sensor 2 assembly using the two screws (Figure 8-9 or 8-14, item 35). Tightening torque is 3 kgf-cm (2.6 in-lb).
16. Install the safety clamp arm cover. Tightening torque for the arm cover securing screw (Figure 8-7 or 8-12, item 2) is 1 kgf-cm (0.9 in-lb). Remove the thickness gauge.
17. Install pump head assembly into the case in accordance with Section 6.3.8.
18. Install the pump door cover in accordance with Section 6.3.4.
19. Perform the Operational Checkout procedures in Section 7.

### 6.3.15 Spring Retainer Removal

The spring retainers are installed into the slide clamp slots at the factory to maintain proper tension on the springs within the assemblies. They must be removed prior to use if the slide clamp feature is enabled.

1. Open the pump door. See Figure 1-2 for the location of the spring retainer.

2. Press the safety clamp arm cover in until the safety clamp latches open.
3. Using E-ring pliers, insert the tips into the holes in the spring retainer.
4. Gently remove the spring retainer. Store the removed spring retainers in a safe place in case they are needed in the future.
5. Close the pump door to release the latched mechanism.

### 6.3.16 Spring Retainer Installation

The spring retainers are installed into the slide clamp slots at the factory to maintain proper tension on the springs within the assemblies, as well as, to help prevent the ingress of fluids into the mechanisms. If the spring retainers have been removed, you will need to reinstall them prior to operating the device with the Slide Clamp feature off.

1. Open the pump door and insert the Slide Clamp Resetting Tool into the slide clamp mechanism until it stops (this tool cannot be pushed in fully). See Figure 1-2 for the location of the slide clamp slot.
2. Press the safety clamp pin to release the slide mechanism. This pushes out the tool slightly.
3. Carefully remove the tool. If the slide clamp mechanism was activated properly, the ridges on both sides of the tool should rub against the claws of the mechanism.
4. Insert the spring retainer until it locks in place.

### 6.3.17 Replacement of Back Plate

1. Remove the pump door cover in accordance with Section 6.3.4.
2. Remove the back plate cover (Figure 8-5, item 16) by removing the screw inside the door (item 27). Then remove the 7 screws (Figure 8-5 or 8-10, item 26) from the outside of the door. **Perform this step carefully to avoid losing springs (item 18).**
3. Remove the 5 springs (item 18) and the back plate (item 17).
4. Install the replacement back plate. Ensure that the back plate is clean and not worn. Ensure that the notch in the back plate aligns with the tongue in the door. Ensure that all 5 springs (item 18) are in place and perpendicular to the back plate cover.

5. Install the back plate cover (item 16) in reverse order. Apply pressure to the back plate cover and install the screws (items 26 and 27) working from the outside edges to the center. That is, install the top and bottom screws first, followed by the screws in the center of the back plate cover. Before tightening these screws, press the back plate a few times from the inside of the door to ensure smooth operation. Tighten these screws to 6 kgf-cm (5.2 in-lb).
6. Replace pump door cover in accordance with Section 6.3.4.
7. Perform the Operational Checkout procedures in Section 7.

### 6.3.18 Replacement of Battery

1. Turn off and unplug the device.
2. Remove the 4 screws (Figure 8-4, item 34) on the battery compartment cover (item 4).
3. Slide the battery assembly out of the rear housing and place it down on the cover.

**Note:** Lead batteries must be recycled or disposed of properly. Contact federal or state environmental agencies for information on recycling and disposal options.

4. Remove the 4 screws (item 34) securing the battery compartment (item 15) to the cover (item 4).
5. Hold the cover and the battery compartment and turn them over, while taking care not to drop them, and then remove the cover.
6. Disconnect the two female connectors from the battery terminals.
7. Reassemble the battery into the device in reverse order. Tightening torque for the five screws is 9 kgf-cm (7.8 in-lb).

**Caution:** Be sure to match up the polarities of the female connectors.

**Red wires (+) must be connected to red marked (+) battery terminal. See the battery label on the underside of the battery cover. The battery must be placed with its connectors up (See Figure 8-4). The wires must be placed in the battery compartment (Figure 8-4, item 15) so that the red (+) battery terminal is positioned next to the bushing (item 21) for the battery harness (item 25).**

**Be sure to place the battery compartment seal (item 20) appropriately in the groove of the compartment.**

**Be sure to place the battery harness behind the printed circuit board and power transformer bracket at left side before placing the battery compartment assembly into the front housing.**

**Be careful not to pinch wires between the front housing and battery compartment cover.**

**Be sure to place the battery cover seal (item 19) appropriately in the groove located on the rear housing.**

8. Perform the Self Test, Section 7.3.2.2 and Battery Check, Section 7.3.8.

### **6.3.19 Replacement of Power Supply Board**

1. Turn off and unplug the device.
2. Separate front and rear housings in accordance with Section 6.3.1.
3. Disconnect CN1 from the power supply board (Figure 8-3, item 18) and the grounding wire of the board from the grounding plate (item 7).
4. Remove four screws (item 22) securing the power supply board.
5. Reassemble in reverse order. Do not pinch the wire harness of CN401 on the terminal board (item 2) between the power supply board and the bosses for it. Tightening torque for the four screws (item 22) securing the board is 7 kgf-cm (6.1 in-lb). Be sure to reconnect CN1.
6. Perform the Operational Checkout procedures in Section 7.



### 6.3.20 Replacement of CPU/Display Board

1. Separate front and rear housings in accordance with Section 6.3.1.
2. Separate boards in accordance with Section 6.3.2.
3. Carefully squeeze the four board spacer tops (Figure 8-2, item 11) with needle nose pliers to release the CPU board (item 3) from the display board (item 2).
4. Lift the Pump 1 side of the CPU board to disconnect CNDISP at the bottom of the board from the display board and pull it perpendicularly to the board.

**Caution:** Be sure to place the CPU board on an insulated surface. Avoid touching potentiometers on the CPU board and the LCDs on the display board during the disassembly/assembly procedures.

5. Reassemble in reverse order. Be sure to check that the Pump 2 side of the CPU board is in the slot of the white PCB holder on the display board and that the connector CNDISP is seated firmly. Be sure to remove any dirt or dust on the LCDs and the windows before tightening the CPU board to the front housing. Tightening torque for board is 7 kgf-cm (6.1 in-lb.).
6. Calibrate in accordance with Sections 6.4.1 through 6.4.6 when the CPU board is replaced.
7. Perform the Operational Checkout procedures in Section 7.

### 6.3.21 Replacement of Audible Alarm/Alert Board

1. Separate the front and rear housings in accordance with Section 6.3.1.
2. Remove one screw (Figure 8-3, item 22) securing the audible alarm/alert board (item 4) to the rear housing.
3. Remove the board and unplug the connector CN753.
4. Reassemble in reverse order. Tightening torque for item 22 is 7 kgf-cm (6.1 in-lb).
5. Perform the Operational Checkout procedures in Section 7.

### 6.3.22 Replacement of Backup Audible Alarm/Alert Board

1. Separate the front and rear housings in accordance with Section 6.3.1.
2. Unplug connectors CN751 and CN752.
3. Remove one screw (Figure 8-3, item 22) securing the backup audible alarm/alert board (item 3) to the rear housing.
4. Remove the board.
5. Reassemble in reverse order. Tightening torque for item 22 is 7 kgf-cm (6.1 in-lb).
6. Perform the Operational Checkout procedures in Section 7.

### 6.3.23 Replacement of Terminal Board

1. Separate the front and rear housings in accordance with Section 6.3.1.

**Note:** Be sure to unlock the connector flange before disconnecting the cable.

2. Unplug connectors CN401, CN701, and ribbon cable connector CNI/F2 (Figure 8-3, item 2) from the terminal board.
3. Remove three screws (Figure 8-3, item 22) securing the terminal board to the rear housing.
4. Remove the board.

**Note:** Be sure to unlock the connector flange before connecting the cable and then push it in to lock.

5. Reassemble in reverse order. Tightening torque for item 22 is 7 kgf-cm (6.1 in-lb).
6. Perform the Operational Checkout procedures in Section 7.

### 6.3.24 Replacement of Power Transformer

1. Separate the front and rear housings completely in accordance with Section 6.3.1.
2. Desolder the black and white wires from the transformer at the fuse holders (Figure 8-4, item 28).

3. Disconnect 2-pin connector CN1 from the power supply board (Figure 8-3, item 18).
4. Remove the transformer by removing two securing screws (item 21).
5. Remove the transformer mounting bracket (item 9) by removing four securing screws (item 23).
6. Reassemble in reverse order. Tightening torque for item 21 is 9 kgf-cm (7.8 in-lb) and for item 23 is 5 kgf-cm (4.3 in-lb).

**Caution:** Be sure to match the color of the wire when resoldering the black and white wires to the fuse holders. Route the wires underneath the transformer mounting bracket (Figure 8-3, item 9) and the insulation film (item 25) under it before replacing the bracket.

**Do not pinch the wires between the bracket and the rear housing.**

**Be sure to secure the two ground wires by the screw (item 21) on the right side of the power transformer (item 19) to the mounting bracket (item 9). Align the power transformer so that the 2-pin connector is on top.**

7. Perform the Operational Checkout procedures in Section 7.

### 6.3.25 Replacement of the PANEL LOCK Switch

1. Separate front and rear housings in accordance with Section 6.3.1.
2. Pull out the black pushbutton cover (Figure 8-4, item 7) on the back of the device while holding the rear housing.
3. Desolder the pink and brown wires from the switch.
4. Remove hex nut and lock washer securing the switch and remove it.
5. Reassemble in reverse order.
6. Perform the Operational Checkout procedures in Section 7.

### 6.3.26 Replacement of Lithium Backup Battery

The lithium backup battery provides backup voltage to the device's memory when the main battery is disconnected. **To avoid loss of configuration option settings, record the settings (See Section 1.5.1) and ensure that the main battery is connected before beginning this procedure.**

1. Separate front and rear housings in accordance with Section 6.3.1.
2. Separate boards in accordance with Section 6.3.2.
3. Separate display board in accordance with Section 6.3.19.
4. Cut the tie wrap holding the lithium battery on the display board (Figure 8-2, item 2).
5. Disconnect connector CN304 and remove the lithium battery.
6. Install replacement battery in reverse order.
7. Verify that the configuration option is set as desired and modify if necessary (See Section 1.5.2).
8. Perform the Operational Checkout procedures in Section 7.

### 6.3.27 Tube Guide Shim Installation

#### Required Parts

Air Sensor Tubing guide shim (Part no. 722003396)

Loctite\* Prism 454 adhesive (Part no. 722003397)

Cellophane tape

**Note:** Open the pump head door and check for a white tubing guide shim or a letter "A" on the door opposite the air sensor. If the shim or letter "A" is present, it is NOT necessary to perform this procedure.

**Note:** Make sure the pump is not plugged into AC power. Clean the tube guide area on the door with a small paint brush soaked in a solution of dishwasher and then rinse with clean water. Use a clean, dry air source to dry the tube guide area or allow to air dry.

\*Loctite, Inc.

1. Lay the pump on its side opposite this pump head. Place the tube guide shim on the tube guide and note the surfaces making contact with the tube guide for the adhesive application on the next step. To help handle the shim, press a 3-inch piece of cellophane tape onto the shim, lengthwise. Use the tape to lift the shim from the door. Save the tape and shim combination.
2. Use the applicator on the tube to apply a thin, uniform layer of Loctite\* Prism 454 adhesive to the surfaces of the tube guide to which the shim is to be bonded. **To achieve a good bond you must apply adhesive to all of the shaded areas** (See Figure 6-1).

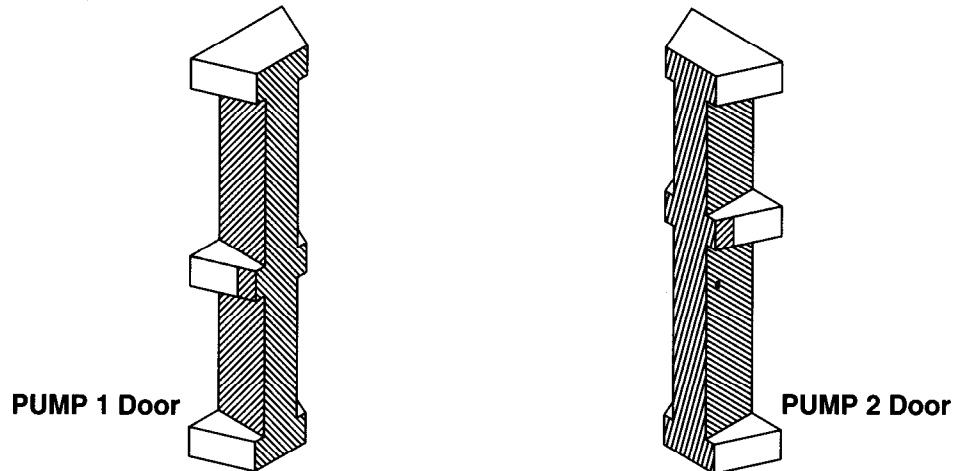

*Figure 6-1. Adhesive Application*

3. Immediately place the shim back onto the tube guide using the tape as a handling aid and apply finger pressure to the corner of the shim at a 45° angle as indicated in Figure 6-2. Apply pressure at the ends as well as at the middle of the shim. The tape acts as a barrier preventing adhesive from contacting the fingers.

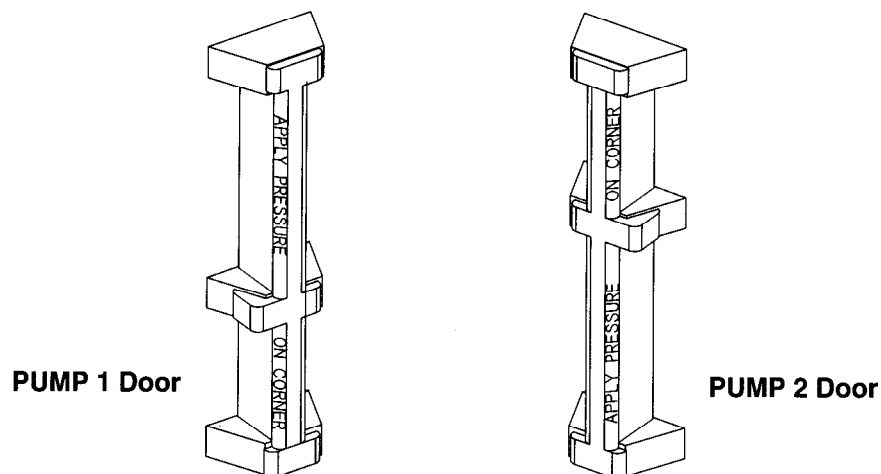

*Figure 6-2. Pressure Application Points*

\*Loctite, Inc.

4. Hold the shim motionless for 60 seconds while continuing to apply pressure.
5. Remove the tape and visually inspect the shim for excess adhesive. Remove excess adhesive using a dry cotton swab.
6. Ensure that the shim is properly bonded to the door by verifying that there are no gaps between the shim and the tubing guide. Use a fingernail to attempt to lift each end and the middle section of the shim to verify that the bond is secure.
7. Perform the Operational Checkout procedures in Section 7.

### **6.3.28 LCD Cushion Installation**

**Note:** These instructions are for devices that exhibit blanking displays. Cushions will be installed on the inside of the case to keep the case interior from touching the LCD.

#### **Equipment**

#2 Phillips Screwdriver or power screwdriver  
Indelible ink (permanent marker)

#### **Parts**

1 ea. LCD cushion (Part no. PCUSU101.A)  
1 ea. Upgrade Label (Part no. 072601047)

1. Turn off the device and make sure it is disconnected from AC power.
2. Separate the case halves as described in Section 6.3.1 (the ground wire does not have to be removed).

**Note:** Carefully lift and remove the pump head wire assemblies on the CPU board if they are routed between the hybrid circuits, HIC301 and HIC302.

3. Remove the circuit boards from the case (Section 6.3.2).

**Note:** It is not necessary to disconnect CN201 and CN803. The CPU/Display board assembly can be placed beside PUMP 1.

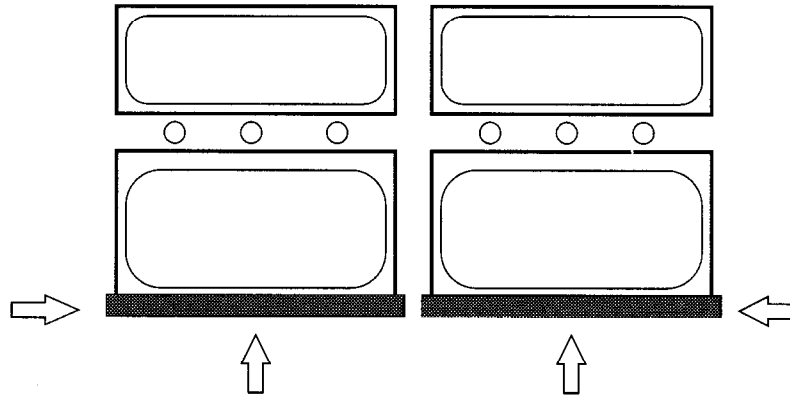

*Figure 6-3. LCD Cushion Placement (Inside View)*

**Important:** The LCD cushion is installed on the inside of the front case housing **NOT** on the LCD.

4. Peel off the adhesive backing and install the LCD cushion across the bottom edge of the inset (recessed area for the LCD). See Figure 6-3. If properly positioned, you should be able to feel a ridge (the inset edge) in the center of the LCD cushion. The cushion should also be centered from left to right. Ensure that the cushion is not visible in the display window when looking at the outside of the case.
5. Remove the adhesive backing from the upgrade label (Part no. 072601047) and install it between the feet on the front case half. Use indelible ink (permanent marker) and mark box number 1.
6. Assemble the pump by performing applicable previous steps in reverse order.
7. Perform the Operational Checkout procedures in Section 7.

### 6.3.29 Software Installation

#### Equipment

#2 Phillips Screwdriver  
I.C. Removal Tool  
I.C. Insertion Tool

#### Parts

1 EPROM with master software (-MAS - as necessary)  
1 EPROM with slave software (-SLV - as necessary)

**Note:** There are two EPROMs available for replacement/upgrade in this device. Although the parts (IC) are the same, it should be noted that the software code contained in each is different. Therefore, ensure that the correct part is installed into the correct location.

**Note:** This device uses CMOS circuitry. Therefore, take steps to prevent damage caused by electrostatic discharge. This includes the use of ground straps grounded work surfaces.

### **EPROM Installation**

1. With the pump powered off, press and hold the SILENCE key then press either ON/OFF CHARGE key. Record the software version number shown on the lower right corner of the main display of PUMP 2.
2. Power off the device and make sure it is disconnected from AC power.
3. Remove the 4 corner screws (Figure 8-4, item 34) that hold the battery access cover (item 4) in place.
4. Tilt the device back and carefully pull out the battery compartment (item 31) and cover.
5. Remove the 4 screws (item 34) which hold the battery compartment to the cover and disconnect the battery wires.
6. Remove the EPROM(s) using the I.C. removal tool.

**Note:** The Master EPROM is located below the Slave EPROM (designated on the board). Also, note that the orientation of both EPROMs is with the notch pointed up.

7. Use an IC insertion tool to install the new version EPROM(s). Make sure that all of the pins are seated in the socket correctly, and that the notched ends of the EPROM(s) are pointed up.
8. Replace the battery (Section 6.3.18). Connect the battery wires to the battery (check polarity) and slide the battery carefully into the battery compartment.

**Note:** If the secondary alarm is activated, press the ON/OFF CHARGE key to stop the alarm. (If a failure code appears, perform steps 1-5 in the Set Configuration section.).

9. Set the configuration to its original settings per Section 1.5.2.
10. Perform the Operational Checkout procedures in Section 7.



## 6.4 Calibration

Read all steps in this procedure prior to calibration of the device. Be sure that all of the necessary equipment is available before beginning calibration procedures. **During calibration it is important to keep the connectors clean.**

**The device should be powered off for at least two hours before beginning calibration. All calibration procedures should be performed in ambient and solution temperatures of 22°C to 28°C (72°F to 82°F).**

### 6.4.1 DC Line Voltages

Verify DC line voltages prior to performing other calibrations. (Further calibrations will not be reliable if DC line voltages are out of specification.) If the DC voltages are not within specification, check the appropriate DC power supply circuit.

The following section may be used to verify various voltages and signals without disassembling the device. Measurements should be made with the device on AC power.

1. Remove the battery access cover (Figure 8-4, item 4) by removing 4 securing screws (Figure 8-4, item 34) and remove the battery compartment assembly from the rear housing.
2. Locate connector CNTEST1 at Pump 1 side on the CPU board.

**Note: Connections called out in the following steps refer to connector CNTEST1. Pin 8 (top pin) of CNTEST1 is signal ground.**

3. Connect a voltmeter to V<sub>main</sub> (pin 6). With the device powered off, the reading should be  $13.65 \pm 0.15$  VDC. The ripple voltage should be measured using an oscilloscope or using a 0.1  $\mu$ F capacitor with the lead connected in series and the voltmeter set to AC. The ripple voltage should be  $\leq 100$  mVp-p at 105 VAC.
4. Connect the DC voltmeter to V<sub>ref</sub> (pin 1). Power up the device. While both pumps are in STOP mode, the voltage should be  $5.000 \pm 0.050$  VDC.
5. Measure the V<sub>cpu</sub> voltage at pin 3. The voltage should be  $5.00 \pm 0.30$  VDC.
6. Verify the V<sub>key</sub> voltage at pin 5. The voltage should be  $5.00 \pm 0.30$  VDC.
7. Verify the V<sub>oth</sub> voltage at pin 4. The voltage should be 12.90 to 13.90 VDC.
8. Verify the lithium backup battery voltage at pin 7. It should be 3.0 to 3.4 VDC.
9. Press the ON-OFF/CHARGE key to turn off the device. Disconnect all test equipment.

10. Replace the battery cover.
11. If the values are outside of specifications, calibrate the voltages as follows:
12. Connect the calibration circuit shown in Figure 6-4.

Variable transformer; 100 - 135 VAC, minimum 50 VA  
 Digital voltmeter: 4.5 digits with  $\pm 0.1\%$  accuracy at 20 VDC range and  $\pm 3\%$  accuracy at 100 - 135 VAC range  
 DC ammeter: 2 ADC in 0.01 A increments  
 Power transformer: RTRNP100.F  
 Resistive load consisting of a 5  $\Omega$ , 20 watt resistor in series with a 5  $\Omega$ , 20 watt potentiometer (See Figure 6-4).

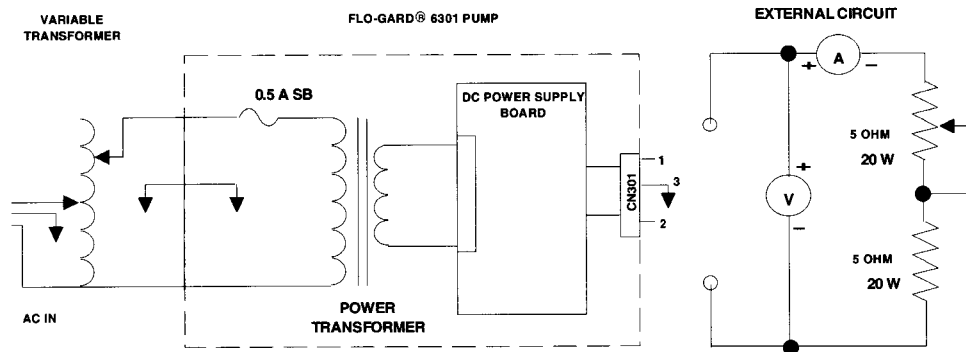

*Figure 6-4. Calibration Equipment Setup*

13. Calibration Set Up
  - a. Separate the front and rear housings completely in accordance with Section 6.3.1.
  - b. Disconnect the power supply connector (CN301) from the CPU board (Figure 8-2, item 3) and connect it to the electronic load.
  - c. Connect the circuit as illustrated in Figure 6-4 with the positive lead connected to pin 2 and the negative lead connected to pin 3.
  - d. Plug all calibration equipment into a  $115 \pm 5.0$  VAC, 60 Hz power source with the following settings:
    - Variable transformer - 0 V or minimum setting
    - Minimum current setting - constant current mode

- e. Turn both potentiometers VR1 and VR2 on the DC power supply board (Figure 8-3, item 18) fully clockwise.
- f. Set the DC ammeter to the appropriate range and the DC voltmeter to 20 VDC range. Do not use autorange.

#### 14. Calibration of Output Voltage by VR2

- a. Ensure the AC power plug of the device is connected to the variable transformer.
- b. Adjust the variable transformer output to 120 VAC. The voltage may be checked with an ordinary tester with  $\pm 3\%$  accuracy.
- c. Connect the resistive load and adjust the potentiometer until the output current is 1.40 A.
- d. Slowly turn VR2 counterclockwise until the voltage between pin 2 (+, red) and pin 3 (-, black) is 13.65 V  $\pm 0.05$ , -0 V. To maintain this VR2 value while still maintaining the output current of 1.40 A, minute adjustments may need to be made to both the potentiometer on the load and VR2.
- e. Check that the voltage between pin 1 (+, yellow) and pin 3 (-, black) is between 13.8 and 14.5 V.
- f. Disconnect the resistive load and check that the voltage between pins 2 and 3 at no load is  $13.7 \pm 0.1$  V.

#### 15. Calibration of Output Current Limit by VR1

- a. Adjust the variable transformer output to 100 VAC and adjust the resistive load for an output current of 1.5 A.
- b. Slowly turn VR1 counterclockwise until the voltage between pin 2 (+, red) and pin 3 (-, black) is  $11.5 \pm 0.5$  V.
- c. Adjust the variable transformer output to 135 VAC and check that the voltage between pin 2 (+, red) and pin 3 (-, black) is  $13.65 \pm 0.1$  V.
- d. Turn the device off and disconnect the external circuit.

#### 16. Reassemble the device.

### 6.4.2 Air Sensor Calibration

**Note:** This section must be performed if the pump head, CPU board, air sensor, door/door assembly, door latch, or latch pin is replaced.

Verify if a modification to the pump head door is necessary to complete this calibration procedure. Open the door and check for a white tubing guide shim or a letter "A" on the door, opposite the air sensor. If the shim or letter "A" is present, the modification was already performed. Proceed to step 1 below.

If the white tubing guide shim or letter "A" is NOT present, go to Section 6.3.27 to install the tubing guide shim.

1. Modify an I.V. tubing set by cutting the tubing about 6 inches below the first Y-site and splicing in a length of calibration tubing (Part no. 3-2-92-479) using tubing connectors. Fully prime the set with distilled water.

**Note:** This fluid filled tube, along with a dry calibration tubing segment, will be used to calibrate the pump. These sections of tubing should only be used to calibrate five pumps with the tubing moved to an unused section for each pump tested. After calibration of the fifth pump, discard the segments and replace them with new ones.

2. Place the device upright. If the case is not already opened, separate the front and rear housings (See Section 6.3.1), but do NOT remove any connectors. Plug the pump into AC power.

**Warning:** When working on an open pump, an electrical hazard exists when the pump is plugged into AC power.

3. Set the device to Test Mode 2 . Press and hold the CLEAR TOT VOL and "2" keys, then press either ON/OFF CHARGE key. Release the ON/OFF CHARGE key without releasing the CLEAR TOT VOL and "2" keys for at least three seconds. The pump is in Test Mode 2 when **NORM** and **MIN** are displayed on the left side of the message (upper) display. If the pump is not in Test Mode 2, turn it off and repeat this step.
4. Using the set assembled in step 1, load the fluid-filled calibration tubing segment into the pump head and close the door. Open and close the pump door two more times and wait two minutes.

5. Adjust the **NORM** value (PRI RATE window) and the **MIN** value (PRI VTBI window) using VR801 for PUMP 1 or VR802 for PUMP 2. Take the greater of the **NORM** and **MIN** values and calibrate to  $450 \pm 20$  (430 – 470). If the lesser value is less than 410, adjust it up so that it is just above 410. Recheck that the greater of the **NORM** and **MIN** values is still within 430 - 470. If both the **NORM** and **MIN** air sensor values are within the specified ranges, continue to the next step. If these ranges cannot be achieved, replace the air sensor per Section 6.3.11. After the air sensor is replaced, start this section with step 2.
6. Remove the fluid-filled tubing from the pump head. Load an air-filled piece of calibration tubing into the pump head and close the door. Open and close the door two more times and wait two minutes.
7. Proceed to the next step if the values are 5 or less. If the values are greater than 5, adjust VR801 for Pump 1 and VR802 for Pump 2 so that the higher of the **NORM** and **MIN** values is  $4 \pm 1$ . If adjustment was required, load the fluid-filled calibration tubing into the pump head and close the door. Open and close the pump door two more times and wait two minutes. Verify that both **NORM** and **MIN** values are between 410 and 470.

**Note:** Apply red Glpt\* to VR801.

8. Repeat steps 1-8 for the other pump head.
9. Exit Test Mode 2 by pressing the ON/OFF CHARGE key that was pressed in step 3.
10. Prime and load a Baxter's "s" suffix standard administration set. See Section 7.3.2.1, steps 1-4.
11. Using the precision syringe, introduce an air bubble (25  $\mu$ L for MIN setting, or 50  $\mu$ L for NORM setting) into tubing just above the pump head door. Press and hold the safety clamp arm cover slightly and allow the air bubble to travel to just above the air sensor. Then release the safety clamp arm cover and close the pump door.
12. Turn on the pump, set the Primary Rate to 125mL/hr and Primary VTBI to 1000 mL and start the pump. Ensure that this air bubble is allowed to pass with no alarm.
13. If the air bubble is detected, repeat the calibration procedure. If the air sensor cannot be calibrated, turn off the pump. Replace the sensor in accordance with Section 6.3.11.
14. Repeat steps 10-14 for the other pump head.
15. Perform the Operational Checkout procedures in Section 7. You may wish to perform the Air Alarm Test (Section 7.3.4) prior to the other tests.

\* GC Electronics

### 6.4.3 Downstream Occlusion Sensor Calibration

1. Check calibration as described in Section 5.3.1, steps 1 through 5.
2. If the value is out of specification, calibrate the sensor as follows:
  - a. Remove the pump door cover as described in Section 6.3.4. Loosen and remove the occlusion sensor stop (Figures 8-5 or 8-10, item 19). If the stop is stuck, apply a small amount of isopropyl alcohol to the threads. Wipe the threads clean.
  - b. Apply Loctite\* 211 or 222 to the screw threads of the stop.
  - c. Repeat Section 5.3.1, steps 1 through 5. Reassemble the stop into the pump head door and slowly turn it with a screwdriver until the value displayed in the PRI VTBI window of the appropriate Main Display is between 2998 and 3002. Knock on the center of the door and check that the reading does not change more than 2 counts. Allow the threadlock to set.
  - d. Remove the thickness gauge and place the device upright. Turn the device off.
3. The following procedure confirms that the calibration is correct.
  - a. Load a Baxter's "s" suffix standard administration set, prime it with fluid and close the pump door. **Ambient and liquid temperatures should be between 72° and 82°F (22° and 28° C).**
  - b. Occlude the tubing downstream of the pump.
  - c. Turn the pump on and set the Primary Rate to 125 mL/hr and Primary VTBI to 50 mL.
  - d. Start the pump and ensure that a downstream occlusion alarm occurs.
  - e. Press and hold the SILENCE and TOT VOL STATUS keys until an Alarm Code appears in the lower right corner of the Main Display. The Alarm Code should be 2 or 3.
4. Turn off the device and reassemble the pump door cover.

\* Loctite, Inc.

#### 6.4.4 Upstream Occlusion Sensor Calibration

1. Connect the AC plug of the device to a  $115 \pm 5.0$  VAC 60 Hz power source. Enter Automatic Test Mode 1 and check the calibration as described in Section 5.3.1, steps 7 through 9.
2. If the value is out of specification, calibrate the sensor using the following procedure:
  - a. Remove the pump head door cover as described in Section 6.3.4.
  - b. Loosen and remove the occlusion sensor stop (Figures 8-5 or 8-10, item 19). If it is stuck, apply a small amount of isopropyl alcohol to the threads. Wipe the threads clean.
  - c. Lay the pump on its rear and place the thickness gauge on the upstream occlusion sensor. Then close the pump door.
  - d. Apply Loctite\* 211 or 222 to the threads and reassemble the stop in the door. Slowly turn it with a screwdriver until the value in the PRI RATE window of the appropriate Main Display is between 3273 and 3277. Knock on the center of the door with the back of fingers and check that the reading does not change more than 2 counts. Allow the threadlock to set.
  - e. Remove the thickness gauge and stand the device upright. Turn the device off.
3. The following procedure confirms that the calibration is correct.
  - a. Load a Baxter's "s" suffix standard administration set, prime it with fluid and close the pump head door. **Ambient and liquid temperatures should be between 72° and 82° F (22° and 28° C).**
  - b. Apply an upstream occlusion.
  - c. Turn the appropriate pump on and set Primary Rate to 125 mL/hr and Primary VTBI to 50 mL.
  - d. Start the pump and ensure that an upstream occlusion alarm occurs.
  - e. Press and hold the SILENCE and TOT VOL STATUS keys until an Alarm Code appears in the lower right corner of the appropriate Main Display. The Alarm Code should be 4, 5 or 12.

\*Loctite, Inc.

4. Turn off the device and reassemble the pump door cover. See Section 6.3.4.

### **6.4.5 Slide Clamp Sensor Calibration**

1. Equipment required

2-channel oscilloscope with input impedance of 10 Megohms or higher (DC Voltmeter can also be used)

Slide Clamp (Part no. 030216490)

Screwdriver with flat tip (2.5 to 3 mm width, ceramic or insulated type preferred) for potentiometer calibration

Cotton-tipped swabs

2. Preparation

- a. Turn off the device.
- b. Press the safety clamp arm cover in until the safety clamp latches open.
- c. Use a C or E-ring tool to remove the spring retainer from the slide clamp slot if one is present.
- d. Use a cotton-tipped swab dampened with water to clean the safety clamp sensor. This sensor is located approximately 1/4" in at the upper left of the slide clamp slot. Repeat with a second dampened swab. Allow to dry before proceeding.
- e. Separate the front and rear housings in accordance with Section 6.3.1.

3. Slide Clamp Sensor Calibration

- a. Connect the device to a 115 VAC, 60 Hz AC power source.
- b. Disconnect and reconnect the slide clamp sensor connector (CN803 for PUMP 1 and /or CN804 for PUMP 2).
- c. To calibrate PUMP1, connect a voltmeter to Pin 3 of CNTEST2 and Pin 5 for ground. Use Pin 1 for PUMP 2.
- d. Enter Automatic Test Mode 1 by pressing and holding the CLEAR TOT VOL and 1 keys while pressing either ON/OFF CHARGE key.



**Important:** If the potentiometer(s) in step e. cannot easily be moved from their present settings, they have been sealed with Loctite\* 211 or 222. To loosen the varnish, apply one or two drops of isopropyl alcohol to the affected potentiometer(s) and wait one minute before trying to move them again.

- e. Insert the slide clamp (Part no. 030216490) and close the door. Verify that the voltage at the appropriate test point is 0.25 V or less. If the voltage is greater than 0.25 V, then attempt to adjust the voltage by turning the potentiometer VR805 for PUMP 1, or VR803 for PUMP 2, fully clockwise. Replace the safety/slide clamp assembly if it cannot be calibrated (Section 6.3.14).
- f. Without the slide clamp inserted and the door closed, verify that the voltage at Pin 3 for PUMP1 and/or Pin 1 for PUMP 2 is 4.2 V or greater. Replace the safety/slide clamp assembly if it cannot be calibrated (Section 6.3.14). Repeat this procedure for the other pump.

**Note:** Apply a thin film of red Glpt\*\* to the appropriate potentiometer to lock it in position.

4. Perform the Operational Checkout procedures in Section 7.

#### 6.4.6 Slide Shaft Sensor Calibration

**Notes:** This calibration must be done after the slide clamp sensor has been calibrated.

**Early production units may contain potentiometers VR804 and VR806 instead of jumper wires soldered across the holes. If your unit contains these potentiometers, you must perform this procedure, otherwise skip this procedure.**

1. Connect the device to  $115 \pm 5.0$  VAC 60 Hz power source. Enter Automatic Test Mode 1 by pressing and holding the CLEAR TOT VOL and 1 keys while pressing the ON-OFF/CHARGE key.
2. Insert the slide clamp and keep the pump door opened.
3. Rotate potentiometer VR806 (Pump 1) or VR804 (Pump 2) fully counterclockwise and check the voltage at Pin 4 for PUMP 1, and/or Pin 2 for PUMP 2, is 0.2 V or less.
4. Close the door and check that the reading is 4.2 V or more.

\* Loctite, Inc.

\*\*GC Electronics

5. Insert the slide clamp and check that the reading is 0.6 V or less with the door opened.
6. Replace the safety/slide clamp assembly if it cannot be calibrated (Section 6.3.14). Repeat this procedure for the other pump.

**Note:**           **Apply a thin film of red Glpt\* varnish to the appropriate potentiometer to lock it in position.**

#### **6.4.7 A/D Converter Reference Voltage Calibration**

1. Separate the front and rear housings (See Section 6.3.1).
2. Connect a digital voltmeter between pin 1 (+) and pin 8 (-) of the CNTEST1 connector.
3. Connect the AC plug of the device to a  $115 \pm 5.0$  VAC 60 Hz power source.
4. Adjust potentiometer VR501 until the meter reading is  $5.000 \text{ V} \pm 0.050 \text{ V}$ .
5. Disconnect all test equipment. Reassemble in reverse order.

\*GC Electronics

# Section 7

---

## Checkout

### 7.1 Introduction

The Operational Checkout procedures in this section determines if the device operates properly after it has been repaired. If the device fails any part of the Operational Checkout, the fault must be corrected prior to placing the device in service. Please become familiar with all the checkout procedures before beginning.

The following test equipment is required to perform the Operational Checkout procedures:

- Baxter's Continu-Flo® administration set with at least one Y-site
- Secondary administration set
- Solution containers (distilled/sterile water, D5W, 0.9% sodium chloride, etc.)
- Precision 100 µL gas-tight syringe (part no. S9662-81 or equivalent)
- Precision 250 µL gas-tight syringe (part no. S9662-82 or equivalent)
- Thickness gauge (part no. UKOG1013.B)
- Tape measure or yardstick

### 7.2 Maintenance Flowchart

Figure 7-1 is a flowchart illustrating the maintenance procedures for this device. The Operational Checkout should be performed after any repairs are performed on the device. Any problems discovered while performing the Operational Checkout should be corrected using the troubleshooting procedures given in Section 3 (Problem Checklist) and Section 5 (Troubleshooting). Once a problem has been isolated to a single assembly, the assembly should be replaced in accordance with the disassembly procedures provided in Section 6. The device should then be calibrated as described in Section 6. After all maintenance procedures are complete, perform the Operational Checkout in this section.

Appendix A contains a data sheet which may be reproduced and used to record the device's configuration settings and the results of the Operational Checkout and calibration procedures.

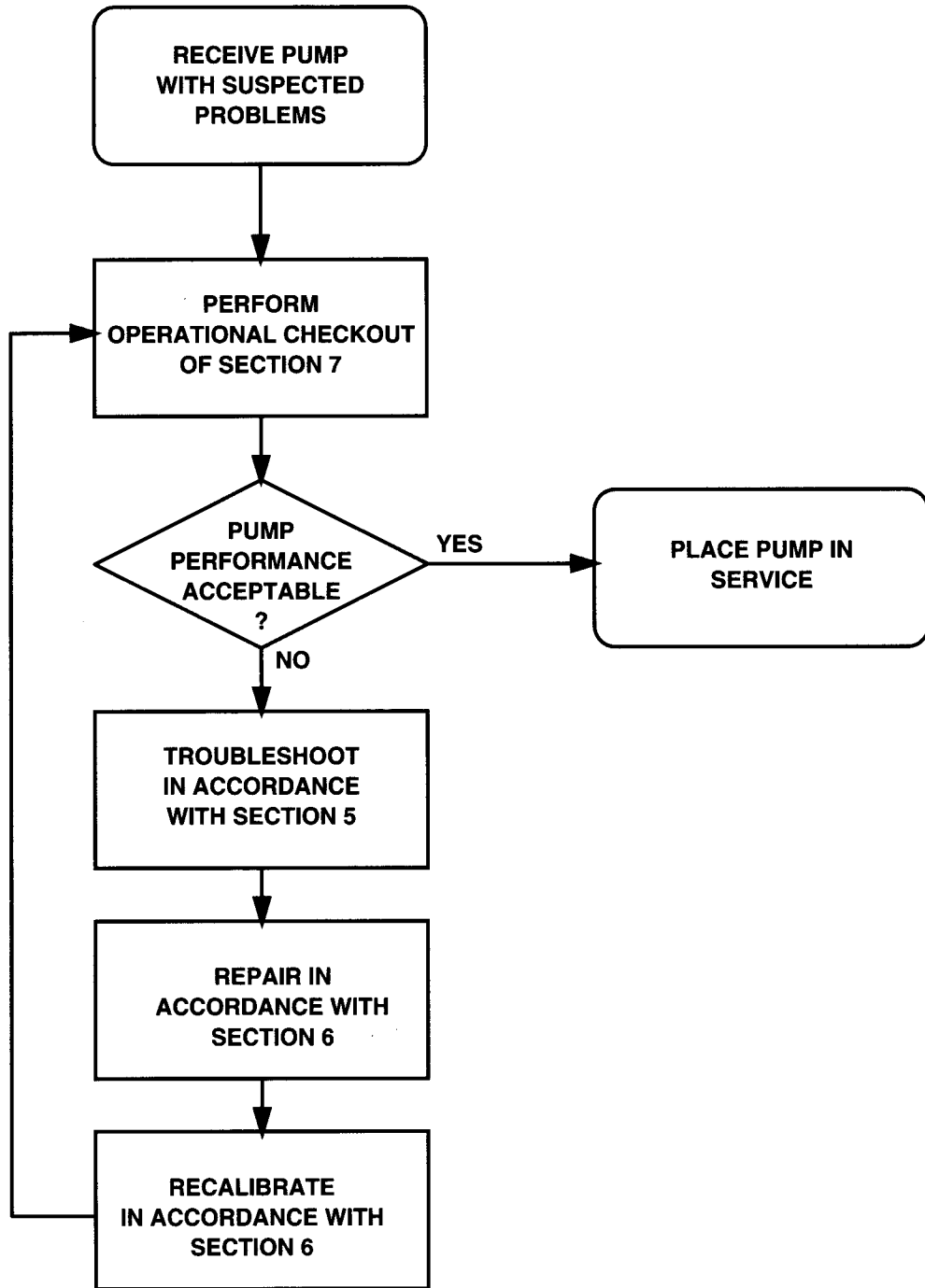

Figure 7-1. Maintenance Flowchart

## 7.3 Operational Checkout

### 7.3.1 Administration Set Placement

To avoid the possibility of fluids contacting the air sensor and pump mechanism, the solution container should be spiked and the set primed before opening a pump door. The container should also be placed low enough to permit a loop in the tubing to the side of the device. Position the container so that accidental spillage onto the device will be minimized. Do not stretch the set when removing it from the packaging.

### 7.3.2 Functional Testing

Please become familiar with the device operating procedures in the Operator's Manual. The procedures in this section are designed to check the ability of the device to pump primary and secondary infusions prior to testing the effectiveness of its alarms. **If either pump fails to perform as described or stops with a failure code alarm, troubleshoot it in accordance with Section 5 and repair it in accordance with Section 6 before attempting to place the device in service.**

#### 7.3.2.1 Preparation for Testing

1. Using a solution container (distilled/sterile water, 0.9% sodium chloride, or D5W) and a Baxter's Continu-Flo® administration set with at least one Y-site, prepare the administration set according to instructions accompanying the set.
2. Spike the solution container and fully prime the set. Remove all trapped air bubbles from all set components. Hang the solution container such that the fluid level is a minimum of 18" above the top of the pump handle throughout the test.

**Make sure that the tubing is clean and dry before placing it in the pump. Make sure that the tubing is placed and seated properly in the guide channel, pump mechanism, sensors and safety clamp. Ensure that there is no slack in the tubing and that it is not kinked or pinched before closing the pump door.**

3. Load the set into the pump. Close the pump door. If excessive resistance is felt, check that the set is loaded properly through the tubing guides. Never use tools or excessive force to close a pump door.
4. Place the distal end of the administration set in a container or sink to dispose of pumped solution.

### 7.3.2.2 Self-Test

Turn pump(s) on by pressing appropriate ON/OFF CHARGE key(s). Check that the device performs the following self-test:

1. The following displays for both channels illuminate momentarily:

ALARM, PUMPING and ALERT LEDs  
OPTIONS and NEXT indicators  
COMPUTER CONTROL and MONITOR icons  
Plug icon or Battery icon is also illuminated, depending on the device's power source.

2. All segments of the Pump 1 and Pump 2 Message and Main Displays illuminate momentarily.
3. The Hospital Area Designator is displayed for 3 seconds in Pump 1 Message Display if the configuration option is selected. The occlusion detection level is momentarily displayed in the message display (**LEVEL 1, 2, or 3**), followed by **AUDIBLE SWITCHOVER**, if the Audible Switchover option is enabled.
4. If both Auto Restart and Flow Check are selected through the configuration option, the message **AUTO RESTART** appears for one second in Pump 1 Message Display. The **FLOW CHECK** message is displayed when the pump is running.
5. Three distinct audible tones sound.
6. **PRI RATE(s)** and **PRI VTBI(s)** are then displayed. **SEC RATE(s)** and **SEC VTBI(s)** are also displayed if they are not both zero.

### 7.3.2.3 Primary Infusion Test

1. Press the PUMP 1 or PUMP 2 key, as appropriate, to select the desired pump.
2. Press the PRI RATE key and enter a flow rate of 100 mL/hr on the keyboard.
3. Press the PRI VTBI key and enter a volume to be infused (VTBI) of 10 mL on the keyboard.
4. Open the flow control clamp on the administration set.
5. Start infusion by pressing the PRI START key. **If the pump stops with an alarm, refer to Section 3, Problem Checklist.** Let the pump continue to run and proceed to the next step.

6. While the pump is running, check for normal operation without upstream or downstream occlusion alarms and that no air bubbles are seen in the tubing.

To reset the volume previously infused, press the appropriate STOP key, PUMP select key and CLEAR TOT VOL key.

To read the total volume infused and review the infusion settings, press the TOT VOL/STATUS key. **VOLUME INFUSED** will be displayed, followed by the RATE and VTBI of both primary and secondary.

To stop an infusion, press the appropriate STOP key. To restart the pump, press the appropriate PUMP select key and START key.

7. When a pump has delivered the selected volume, the pump activates an audible alert, illuminates the ALERT LED, and switches to a KVO (Keep Vein Open) rate.
8. To stop the infusion, press the appropriate STOP key.

### 7.3.3 Door Open Alarm Testing

The pumps are designed so that they will not operate if the associated pump door is open. Perform the following steps to ensure proper operation of the **DOOR OPEN** alarm.

1. Prime and load a Baxter's "s" suffix standard administration set. Refer to Section 7.3.2.1, steps 1-4.
2. Program a primary rate of 100 mL/hr and a primary VTBI of 10 mL.
3. Close the door and press the PRI START key.
4. Open the pump door. The following should occur:
  - a. **DOOR OPEN** is displayed in the Message Display.
  - b. The red ALARM LED flashes.
  - c. The audible alarm is activated.

**Warning:** If these indications do not occur, remove the device from service. Troubleshoot in accordance with Section 5 and repair in accordance with Section 6.

- d. Repeat the procedure for the other pump.

### 7.3.4 Air Alarm Testing

The air bubble size for air detection is selectable through the configuration option and is factory set to **NORM**. See Section 1.5 for an explanation of the configuration option. **If a pump fails to detect air, remove it from service and troubleshoot it in accordance with Section 5. Repair and calibrate in accordance with Section 6.**

1. Check the air sensor calibration values per Section 5.3.2, steps 1 through 5.
2. Prime and load a Baxter's "s" suffix standard administration set with one Y-site above the device. See Section 7.3.2.1, steps 1-4.
3. Using a precision gas-tight syringe (part no. S9662-81 or equivalent), introduce an air bubble into the administration set through the Y-site above the pump. If the air sensor is set to **NORM**, the bubble should be greater than 110 microliters. If the air sensor is set to **MIN**, the bubble should be greater than 85 microliters.
4. Open the pump door and slightly press the safety clamp arm cover to position the air bubble below the pump fingers and above the air sensor.
5. Close the door and start the pump. When the intact air bubble reaches the air sensor the following should occur:
  - a. **AIR** is displayed in the Message Display.
  - b. The red ALARM LED flashes.
  - c. The audible alarm is activated.
  - d. The pump stops.
  - e. If the pump does not alarm, verify that the bubble did not break up before reaching the sensor and repeat the test.
6. Open the pump door, press the safety clamp arm cover and purge the air from the tube. Close the pump door and press the appropriate pump select key and START key. The pump should now begin operation.
7. Repeat steps 1 through 6 for the other pump.



### 7.3.5 Drive Defect Test/Occlusion Check

With a fluid filled tube loaded into pump head, door closed and all clamps open, program the pump for a rate of 1999 mL/hr and a VTBI of at least 30 mL. Start the pump and allow it to deliver for at least 15 seconds without a downstream occlusion alarm or an F-78 or F-79 alarm. If a downstream occlusion or an F-78 or F-79 alarm occurs, perform the appropriate corrective action in Table 5-1.

### 7.3.6 Downstream Occlusion Testing

If a pump fails to detect a downstream occlusion, the device must be removed from service and repaired. Perform the following steps at room temperature to ensure proper operation of the downstream occlusion sensor.

1. Prime and load a Baxter's "s" suffix standard administration set. See Section 7.3.2.1, steps 1-4.
2. Start the pump at a rate of 125 mL/hr and run for 1 minute.
3. Fold and completely pinch the tubing just below the pump. The **OCCLUSION** message should be displayed in the Message display, the red ALARM LED should flash, the audible alarm should sound and the pump should stop.
4. Repeat the procedure for the other pump.

**Warning:** If either pump does not respond as described, remove the device from service, troubleshoot in it accordance with Section 5, and repair in accordance with Section 6.

5. Turn the pump off and remove the tubing. Check the calibration of the downstream occlusion sensor per Section 5.3.1, steps 1 through 6.
6. Exit calibration mode 1 by pressing the ON-OFF CHARGE key that was pressed in step 2 of Section 5.3.1.

### 7.3.7 Upstream Occlusion Testing

The device is designed to detect a closed clamp upstream of the pump head. Perform the following steps to ensure the performance of the upstream occlusion sensor.

1. Prime and load a Baxter's "s" suffix standard administration set. See Section 7.3.2.1, steps 1–4.
2. Pinch off the tubing with a set clamp or hemostat above the pump head.
3. Set a rate of 125 mL/hr and start the pump.
4. Within three minutes of starting, the following should occur:
  - a. The pump stops.
  - b. The red ALARM LED flashes.
  - c. **UPSTREAM OCCLUSION** is displayed in the Message Display.
  - d. The audible alarm is activated.

**Warning: If these indications do not occur, remove the device from service. Troubleshoot in accordance with Section 5 and repair in accordance with Section 6.**

5. Turn the pump off and remove the tubing. Check the calibration of the upstream occlusion sensor per Section 5.3.1, steps 1 and 7 through 10.
6. Repeat step 5 without the thickness gauge installed. Check that the value displayed in the PRI RATE window of the Main Display is 3180 or less.
7. If the value displayed is out of specification, ensure that the occlusion sensor button is moving freely. If so, repeat Section 6.4.4, steps 2 and 3. If not, replace the Upstream Occlusion Sensor per Section 6.3.9.
8. Exit calibration mode 1 by pressing the ON-OFF/CHARGE key that was pressed in Section 5.3.1.

### 7.3.8 Battery Check

Disconnect the device from AC. Load a primed Baxter's "s" suffix standard administration set, such as 2C5545s into both pumps and start them at 125 mL/hr with a VTBI of 10 mL. Verify that **BATTERY** is displayed and that the unit runs for at least five minutes or pumps 10 mL. Plug the pump into AC and verify that **BATTERY** disappears from the message display.

#### 1. Battery Test (Optional)

**Note:** Charge the battery for at least 16 hours before conducting this test.

- a. Load a primed set into each pump, such as 2C5545s into the pump. Set the PRI RATE to 1901 mL/hr and PRI VTBI to 4800 mL and start each pump.
  - b. Unplug the device while it is running. No change in pumping should occur, but **BATTERY** should be displayed on the message display within a few seconds. The battery requires charging when **BATTERY LOW** is displayed, the audible alarm or alert is activated, and the appropriate LED is illuminated.
  - c. Operate the device on battery power for 2.5 hours. Make sure that the pump does not initiate a **LOW BATTERY** alert before the KVO alert occurs.
  - d. If the unit fails this test, perform the Battery Charging Voltage Check.
  - e. If the device operates satisfactorily on battery power, plug it back in. Operation should continue without interruption and the **BATTERY** message should turn off. Recharge the battery by allowing the device to remain connected to AC power for a minimum of 16 hours.
- #### 2. Battery Charging Voltage Check (Optional)

Perform this check to determine if the charging voltage is correct.

- a. Disconnect and remove the battery from the device. Connect a voltmeter to the pump leads and measure the charging voltage while both pumps are in the KVO mode. It should be between 13.7 and 13.9 VDC. If it is and the device failed the battery test, replace the battery in accordance with Section 6.3.18.
- b. If the charging voltage is NOT between 13.7 V and 13.9 VDC, check the other power supply voltages as described in Section 6.4.1 and repair and/or calibrate the device as necessary.

### 7.3.9 Panel Lock Test

1. With a pump(s) running without alerts, press the PANEL LOCK pushbutton on the rear of the device for one second.
2. Verify that **Loc** is displayed in the Main Display of the powered-on pump(s).
3. Verify that input from the front panel keys is not accepted except from BACKLIGHT and TOT VOL/STATUS.
4. Press PANEL LOCK again. The **Loc** message should disappear, and input from the front panel keys should be accepted.

**Warning:** If any of these indications fail to occur, troubleshoot the device in accordance with Section 5 and repair it in accordance with Section 6.

### 7.3.10 Safety Clamp Test

1. With the administration set loaded into the pump, and the pump not running, elevate the solution container to a head height of 0.7 meters (27 inches) or higher, as measured from the midpoint of the device to the level of solution in the container.
2. Open the roller clamp and close the pump door and observe the distal end of the set for 60 seconds after closing the door.
3. Verify that no more than 1/2 mL of fluid flows in the first 60 seconds and that no gravity flow occurs after 60 seconds.
4. Repeat steps 1 through 3 for the other pump.

**Warning:** If either pump fails to prevent free flow, remove the device from service. Troubleshoot it in accordance with Section 5 and repair it in accordance with Section 6.

### 7.3.11 Alarm Volume

1. Induce an alarm by any convenient means.
2. Rotate the VOLUME knob on the rear of the unit. Verify that the sound level increases as the control is rotated clockwise and decreases as the VOLUME knob is rotated counterclockwise. The alarm/alert sound should be audible at any VOLUME knob position.
3. Set the volume to maximum upon completion of this test.

### 7.3.12 Slide Clamp Test

The Slide Clamp Feature is an alert or alarm option (software versions 1.09 and later) enabled through the configuration utility. When this option is enabled, the slide clamp on the administration set must be loaded into the slide clamp slot. When the infusion is complete, the administration set cannot be easily removed from the pump without first pushing the slide clamp all the way into the slide clamp slot, thus occluding the tubing in the slide clamp. This test verifies that the Slide Clamp Feature is functioning properly.

**Note:** If the Slide Clamp Feature is enabled, the administration set slide clamp must be loaded into the assembly. In the alert mode, the pump operates if the slide clamp is not loaded. In the alarm mode (software versions 1.09 or later), the pump will NOT start and an alarm tone sounds if the slide clamp is not loaded. Use of the Slide Clamp Feature is selected as part of the configuration option before the pump is placed into service.

**Note:** Spring retainers are loaded into the slide clamp slots at the factory to prevent damage during shipment. The spring retainers must be removed before operating the device with the Slide Clamp Feature enabled. If the feature is not going to be used by your hospital, it is recommended that the spring retainers remain in the slots to help prevent spilled solutions from entering the slide clamp slots. Contact Product Service at 1-(800)-THE-PUMP for additional spring retainers.

1. If your hospital does not have the slide clamp feature enabled, ensure that the spring retainers occupy the slide clamp slots and proceed directly to Section 7.3.13.
2. With the device ON, fully insert the slide clamp of a primed Baxter's "s" suffix standard administration set into the slide clamp slot, and load the set into the pump mechanism.
3. Close and latch the pump door.

**Note:** If *INSERT SLIDECLAMP* appears on the display, clean the slide clamp sensor with a cotton-tipped swab dipped in water and check the calibration. Repair or replace as necessary.

4. Open the door. Press the red safety clamp arm with moderate force (approximately 15 lb. [6.5kg]) and verify that the latch will **not** lock in the open position.
5. Using one hand, pull on the slide clamp with moderate force (approximately 15 lb. [6.5kg]) perpendicular to the pump face. Verify that the slide clamp cannot be removed.
6. Push the slide clamp in fully. Verify that the red safety clamp arm can be latched in the open position, and verify that the slide clamp and tubing can be removed.
7. Load the primed set again but do **not** insert the slide clamp into the mechanism. Close the door. Verify that the *INSERT SLIDECLAMP* message is displayed with the alert LED constantly lit, and the audible tone alternately ON and OFF.

**Note:** For pumps with software versions 1.09 or later, the pump will start in the alert mode, but the message remains displayed. The alarm mode will not allow the pump to start.

8. Then partially insert (approximately one-third of the way) the slide clamp. Close the door. Verify that *INSERT SLIDECLAMP* is displayed.
9. Open the pump door and remove the tubing from the device.

**Note:** See the repair section (Section 6) if the pump fails any of these tests.

### 7.3.13 Electrical Safety Tests

1. Test the device's leakage current and ground impedance in accordance with UL 544. Leakage current should not exceed 50 microamps. Measure the ground impedance at the mounting nut of the LOCKOUT switch on the rear of the pump. It should not exceed 0.15  $\Omega$  using a 25 amp, UL-specified test circuit, or 0.15  $\Omega$  using an NFPA-99 or equivalent test circuits.

**Warning:** If the device fails to meet these requirements, remove it from service, troubleshoot it in accordance with Section 5 and repair it in accordance with Section 6.

2. Thoroughly inspect the power cord for signs of wear or damage. Replace it if any pins are broken or the insulation is damaged.

### 7.3.14 Accuracy Tests

Any one of the tests described in this section can be used to test the accuracy of the pump(s). You can perform just the One-Hour Accuracy Test (7.3.14.5), or one of the shorter tests (7.3.14.1 through 7.3.14.4), but the One-Hour Accuracy Test should be performed additionally, if any of the shorter tests fail. Repeat test as needed for additional pumps.

1. Before proceeding with the selected test, perform steps 1- 4 of Section 7.3.2.1.

**Note:** An unused section of a Baxter's "s" suffix administration set or calibration tubing (Part no. 3-2-92-479) can also be used for these tests.

2. Mark the section of the tubing in the pump to indicate that the segment has been used.

**Important:** Do NOT reuse a tubing segment that has already been used to conduct an accuracy test.

**Note:** The accuracy specifications included in these tests account for an extensive list of variables over a short term test cycle. A more precise measurement of flow rate requires longer test times, including statistical trials. However, this is not necessary to demonstrate proper function of the pump.

#### 7.3.14.1 Measurement by weight per time:

1. Program a PRI VTBI of at least 500 mL and start the pump at 200 mL/hr.
2. Collect the solution in a container of known weight for 10 minutes and 30 seconds,  $\pm 3$  seconds.
3. Use a calibrated scale with a resolution of 0.1 grams or better to weigh the container and solution. Then, divide the solution weight by the specific gravity of the solution (water's specific gravity is 1 g/mL).
4. The solution collected should be between 32.5 mL and 37.5 mL.

#### 7.3.14.2 Measurement by volume per time:

1. Program a PRI VTBI of 20 mL and start the pump at 200 mL/hr.
2. Collect the solution in an ASTM Class A 25 mL graduated cylinder, with a resolution of 0.2 mL or better, for 6 minutes  $\pm 3$  seconds or until the pump switches to the KVO mode.

**Important:** Stop the pump within 10 seconds after the KVO alert, since fluid delivered after the KVO alert adds to the test error.

3. The solution collected should be between 18.6 mL and 21.4 mL.

#### 7.3.14.3 Measurement by time per volume:

1. Program a PRI RATE of 200 mL/hr. and a PRI VTBI greater than 35 mL.
2. Measure the time within 3 seconds that it takes to collect 35 mL  $\pm$  0.2 mL.
3. Calculate the flow rate in mL/hr by dividing 35 mL by the measured time converted to hours.

**Note:** The Dynatec Model 404A Flow Analyzer can be used for this method.

4. The flow rate should be between 186.0 and 214.0 mL/hr.

#### 7.3.14.4 Measurement incorporating VTBI option:

1. Program a PRI RATE of 200 mL/hr and PRI VTBI of 35 mL.
2. Start the pump and collect the solution in a container of known weight. When the pump goes into KVO alert mode, stop the pump within 20 seconds.

**Important:** Stop the pump within 20 seconds after the KVO alert, since fluid delivered after the KVO alert adds to the test error.

3. Use a calibrated scale with a resolution of 0.1 grams or better to weigh the container and solution. Then, divide the solution weight by the specific gravity of the solution (water's specific gravity is 1 g/mL).
4. The solution collected should be between 32.5 mL and 37.5 mL.

#### 7.3.14.5 One-Hour Accuracy Test

**Note:** Perform this test if the pump fails tests 7.3.14.1, 7.3.14.2, 7.3.14.3, or 7.3.14.4.

**Important:** Do NOT reuse a tubing segment that has already been used to conduct an accuracy test.

1. Connect the device to AC power and power it on.



2. Program a PRI RATE of 125 mL/hr with a PRI VTBI of 1000 mL.
3. Place the distal end of the infusion set into a container of known weight.
4. Simultaneously, start a timer and press the START key.
5. Stop the pump 1 hour  $\pm$  20 seconds later. Use a calibrated scale with a resolution of 0.1 grams or better to weigh the container and solution. Then, divide the solution weight by the specific gravity of the solution (water's specific gravity is 1 g/mL).
6. The collected solution should be between 116.25 and 133.75 mL.
7. If the volume of the collected solution is NOT between 116.25 and 133.75 mL,
  - verify proper test technique,
  - check for a loose belt,
  - check for a properly moving backplate or damaged backplate springs, or
  - replace the pump head assembly, as necessary.

**Important:** Do NOT run this test again to improve results unless there is reason to believe that the test technique was in error. Replace any pump head that fails this test and be sure to clearly identify it as having failed the One-Hour Accuracy Test.



## Section 8

---

# Illustrated Parts Breakdown

This section includes illustrations and parts lists required to identify any replaceable part in the Flo-Gard® 6301 Dual Channel Volumetric Infusion Pump. Each illustration is keyed to a parts list, which lists each component shown in the figure by part number and description. The quantity per assembly is also shown. The level of assembly is indicated by the number of dots preceding the description. For example, one dot indicates a top-level assembly, two dots indicate a second level subassembly, three dots the third level of subassembly, and so on.

To obtain replacement parts, contact Product Service. The first column shows the item number of each part. The second column is the Product Service part number. The third column is the manufacturer's part number, and the last column is the quantity per assembly. The last two digits of each part number indicate the supplier's revision level and are needed when ordering so that a database search for equivalent parts can be conducted. Orders will be filled with equivalent parts; however, the last two digits of the replacement part number may vary depending upon the currently available revision level. If replacement part number digits other than the last two digits vary, please contact Product Service toll free at 1-(800)-THE-PUMP, to check compatibility.

**Front Housing Assembly - External (Figure 8-1)**

Item	Svc. Part #	Mfg. Part #	Description	Qty
-1	F059120001	F059120001	.. HOUSING, FRONT SUB ASSY . . . . .	1
-2	F059120015	F059120015	... PUMP 1 HEAD ASSEMBLY . . . . .	1
<b>Note: See Figures 8-5 through 8-9 for details on items 1 and 2.</b>				
-3	F049120020	F049120020	... PUMP 2 HEAD ASSEMBLY . . . . .	1
<b>Note: See Figures 8-10 through 8-14 for details on item 3.</b>				
-4	HPNL1026.A	5001474005	.. PANEL, Front . . . . .	1
-5	PGUMM103.K	F044630004	... SEAL, Rubber . . . . .	2
-6	XBPUF30P.A	4009310009	... SCREW, Pan Head, M3X20 . . . . .	2
-7	XBSUF40P.A	4009310015	... SCREW, Flat Head, M4X18 . . . . .	6
-10	GCOVA101.D	F053624003	. COVER, Pump Head 1 . . . . .	1
-11	GCOVA101.E	F053624004	. COVER, Pump Head 2 . . . . .	1
-12	LRTNP100.B	F044620002	. SPRING, RETAINER . . . . .	2
-13	XBSUF30P.A	4009310014	. SCREW, Flat Head, M3X12 . . . . .	10

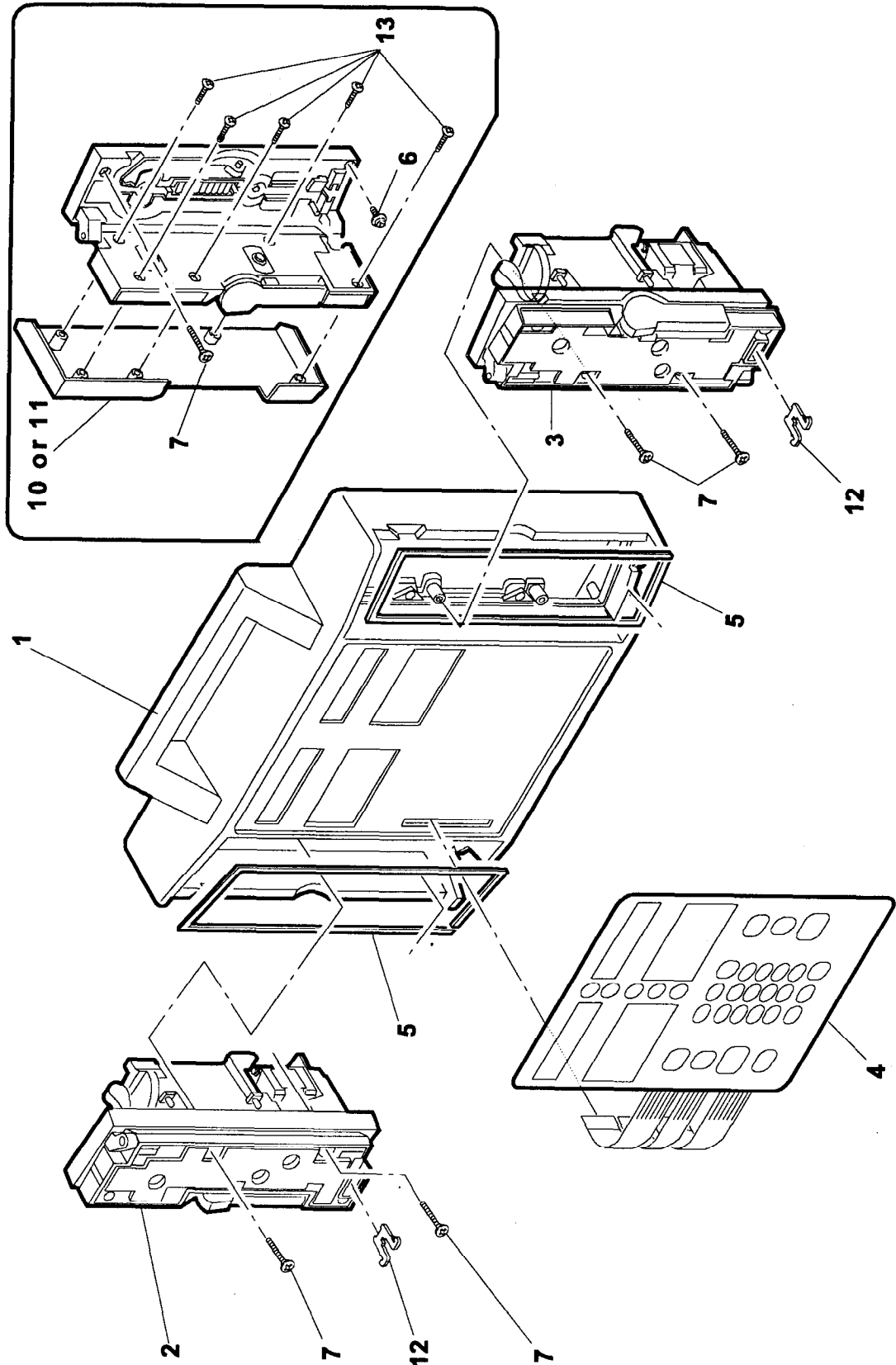

Figure 8-1. Front Housing Assembly - External

**Front Housing Assembly - Internal (Figure 8-2)**

Item	Svc. Part #	Mfg. Part #	Description	Qty
-1	F059120001	F059120001	.. HOUSING, FRONT SUB ASSEMBLY . . . . .	1
-2	CPWBN105.D	F052130001	.. DISPLAY, PCB ASSEMBLY . . . . .	1
<b>Note: See Figure 8-16 for details on item 2.</b>				
-3	CPWBX105.A	F051130002	...CPU PCB ASSEMBLY . . . . .	1
<b>Note: See Figure 8-17 for details on item 3.</b>				
-4	GCABA104.B	F051624001	... HOUSING, Front . . . . .	1
-5	GLEGG100.D	F044630001	... FOOT, Rubber . . . . .	2
-6	LANGT103.B	F042220001	... BRACKET, Pump Head 2, Mounting . . . . .	1
-7	LANGT103.C	F052220001	... BRACKET, Pump Head 1, Mounting . . . . .	1
-8	PGUMM103.G	F054630001	... SEAL, Rubber, Housing . . . . .	1
-9	PSPAF103.A	F044230001	... SPACER, Pump Head 2 . . . . .	1
-10	PSPAF103.B	F054230001	... SPACER, Pump Head 1 . . . . .	1
-11	PSPAN103.A	F049620013	... Spacer, Double Locking PCB . . . . .	4
-12	QCNW1043.B	F044140001	... WIRE, Grounding . . . . .	1
-13	XBPBN30P.A	4009310001	... SCREW, Pan Head, M3X6 . . . . .	1
-14	XBPBN40P.E	4009310003	... SCREW, Pan Head, M4X8 . . . . .	3
-15	XBPSD30P.G	4009310038	... SCREW, Pump Head, M3X6 . . . . .	2
-16	XUPSD30P.B	4009310020	... SCREW, Pan Hd-Tapping, M3X8 . . . . .	12
-17	XWHSD300.C	4009330001	... WASHER, Rubber Foot M3 . . . . .	4
-18	XEPSD30P.A	4009310018	... SCREW, Pan Head, M3X8 . . . . .	4
-19	UBATL100.A	5009480002	.... BATTERY, Lithium . . . . .	1
-20	PSEL1008.A	3004090005	.... SEAL, Dust, LCDs . . . . .	1

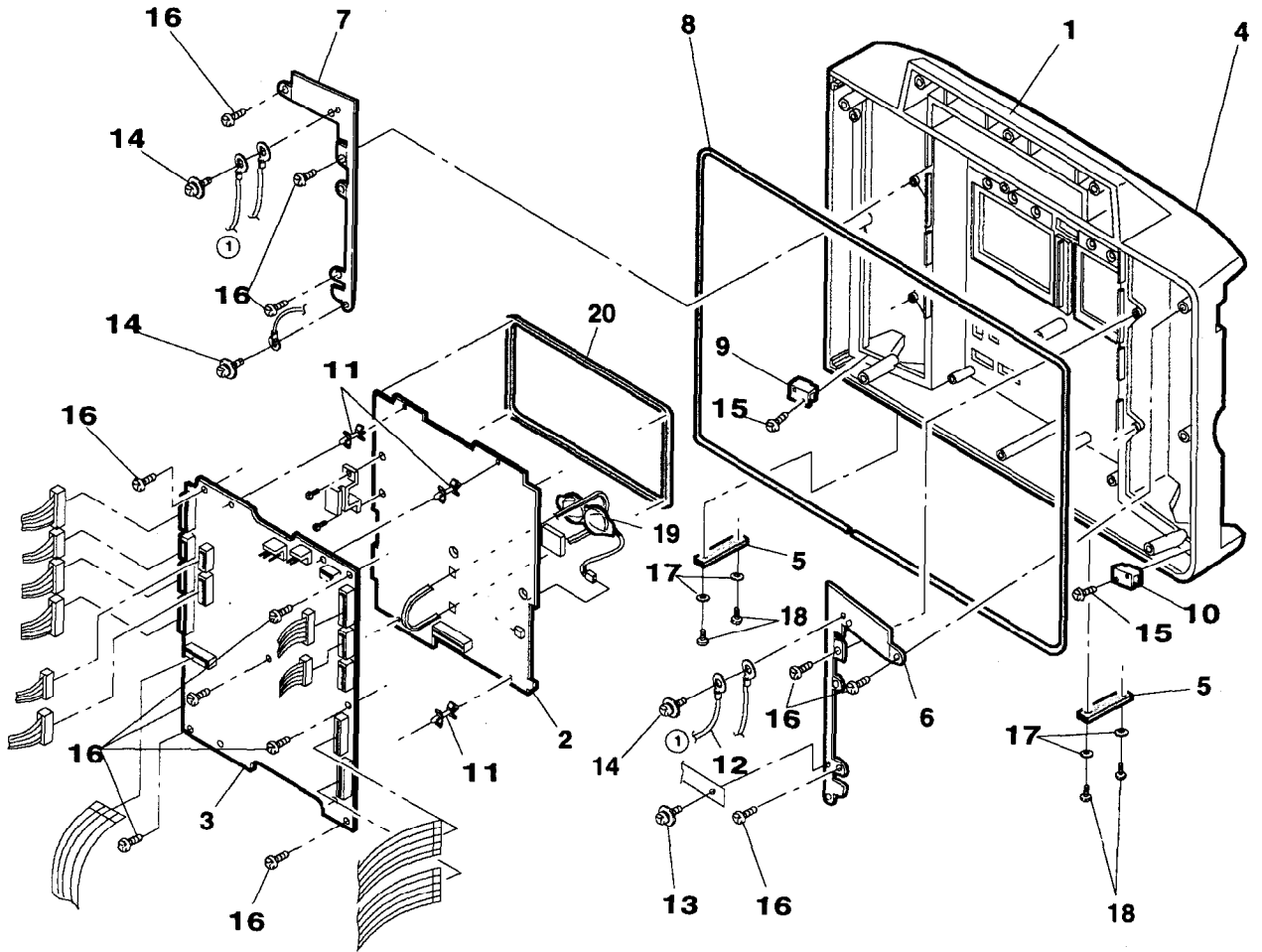

Figure 8-2. Front Housing Assembly - Internal

### Rear Housing Assembly - Internal (Figure 8-3)

Item	Svc. Part #	Mfg. Part #	Description	Qty
-1	DUNT1275.A	F059120008	.. HOUSING, REAR SUB ASSEMBLY . . . . .	1
-2	CPWBN104.B	F043130001	... PCB, ASSEMBLY-Terminal . . . . .	1
<b>Note: See Figure 8-18 for details on item 2.</b>				
-3	CPWBN104.D	F043130003	... PCB ASSEMBLY- Backup Aud Alrm . . . . .	1
<b>Note: See Figure 8-19 for details on item 3.</b>				
-4	CPWBN105.A	F043130004	... PCB, ASSEMBLY-Audible Alarm . . . . .	1
<b>Note: See Figure 8-20 for details on item 4.</b>				
-5	GCABB104.D	F051624002	... HOUSING, Rear . . . . .	1
-6	GLEGG100.D	F044630001	... FOOT, Rubber . . . . .	2
-7	LANGQ103.A	F044211001	... PLATE, Main Ground . . . . .	1
-8	LANGQ103.B	F044220003	... PLATE, Grounding . . . . .	1
-9	LANGT103.D	F054220002	... BRACKET, XFORMER . . . . .	1
-10	PGUMM103.D	F044620003	.. .BOOT, Rubber-Main Buzzer . . . . .	1
-11	PGUMM103.E	F044620004	.. .BOOT, Rubber-Backup Buzzer . . . . .	1
-12	QCNW1043.B	F044140001	... GND WIRE, Front Housing . . . . .	2
-13	QCNW1052.B	F044140003	... GND WIRE, XFORMER . . . . .	1
-14	QCNW1058.A	F044140002	... GND WIRE, Pwr Receptacle . . . . .	1
-15	QCNW1114.A	F052140001	... HARNESS, Buzzer . . . . .	1
-16	QCNW1118.A	5009415002	... CABLE, Flat Ribbon . . . . .	1
-17	QSWP1008.A	5009470002	... SWITCH, Panel Lock . . . . .	1
-18	RDENC100.E	F059130003	..BOARD, ASSEMBLY- POWER SUPPLY . . . . .	1
<b>Note: See Figure 8-15 for details on item 18.</b>				
-19	RTRNP100.F	5009462002	... XFORMER, Power 117V, 60Hz . . . . .	1
-20	RVRC1350.A	2501003200	... POT, Volume Control . . . . .	1
-21	XBPBN40P.E	4009310003	... SCREW, Pan Head-M4X8 w/ washer assy . . . . .	7
-22	XUPSD30P.B	4009310020	... SCREW, Pan Hd-Tapping M3X8 . . . . .	9
-23	XUPSD40P.A	4009310021	... SCREW, Pan Hd Tapping M4X8 . . . . .	4
-24	XWHSD300.C	4009330001	... WASHER, Rubber Foot-M3 . . . . .	4
-25	PZETL102.i	3004010009	... FILM, Power Trans Insulation . . . . .	1
-26	XEPSD30P.A	4009310018	... SCREW, Pan Hd-M3X8 . . . . .	4



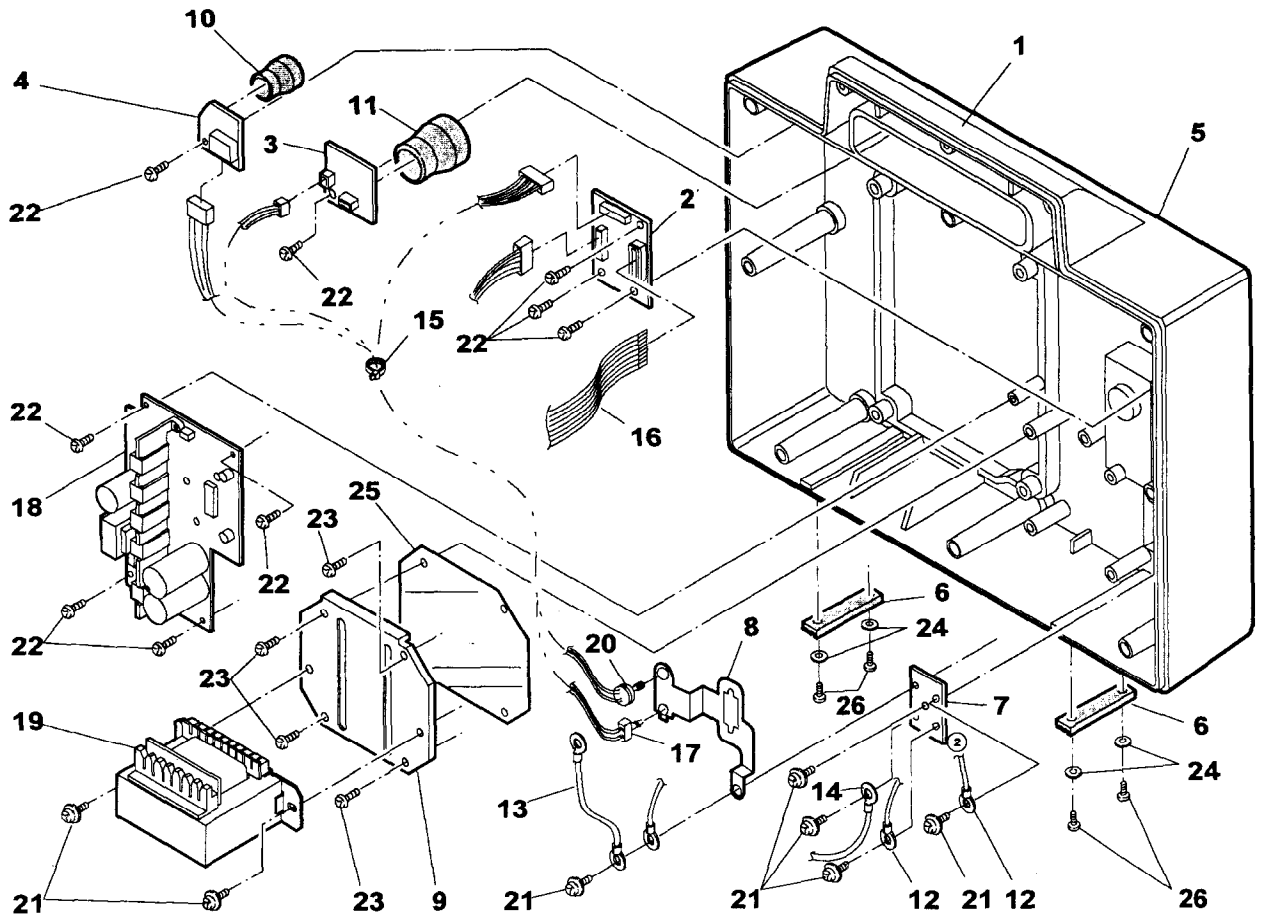

Figure 8-3. Rear Housing Assembly - Internal

**Rear Housing Assembly - External (Figure 8-4)**

Item	Svc. Part #	Mfg. Part #	Description	Qty
-1	DUNT1275.A	F059120008	.. HOUSING, REAR SUB ASSY . . . . .	1
-2	GCASP101.A	F042624007	... BODY, Pole Clamp . . . . .	1
-3	GCOVH100.C	4009390001	... COVER, Comm. Port . . . . .	1
-4	GFTAB101.B	F052624005	... COVER, Batt. Comprtmnt . . . . .	1
-5	JKNBZ100.C	F049620011	... KNOB, Volume Control . . . . .	1
-6	JKNBZ101.B	F044620012	... KNOB, Pole Clamp . . . . .	1
-7	JKNBZ101.C	6009590024	... KNOB, Panel Lock Sw. . . . .	1
-8	LFiX1010.A	F044220004	... DISK, Pole Clamp . . . . .	1
-9	LPLTZ107.A	F044630006	... CUSHION, Pole Clamp . . . . .	1
-10	LXBZ1004.A	4004310023	... SCREW, Pan Head-M4X63 . . . . .	8
-11	LXBZ1019.A	4009310024	... SCREW WITH SNAP, M4X8 . . . . .	1
-12	LXNZ1003.A	F049211002	... NUT, Comm. Port . . . . .	2
-13	LXWZ1007.A	4004330003	... WASHER, Cord Strap M4-ROZET . . . . .	1
-14	NSFTT102.A	F044211003	... SHAFT, Pole Clamp . . . . .	1
-15	PCASB100.A	F052620003	... HOUSING, Battery . . . . .	1
-16	PCUSS102.A	F044630003	... CUSHION, Battery Side . . . . .	1
-17	PCUSS102.B	F054630005	... CUSHION, Battery Surface . . . . .	1
-18	PCUSS103.A	F054630006	... CUSHION, Fuse Holder & Battery . . . . .	2
-19	PGUMM103.L	F054630002	... SEAL, Battery Cover . . . . .	1
-20	PGUMM103.M	F054630003	... SEAL, Batt. Housing . . . . .	1
-21	PGUMM104.A	F054630004	... SEAL, Batt. Comprtmnt . . . . .	1
-22	QFSH5100.A	5009425014	... FUSE, 0.1A, 250V . . . . .	1
-23	PZETL102.J	3004010010	... FILM, Battery, Insulation . . . . .	1
-24	QCNW1092.A	F043140004	... HARNESS, Comm. Port . . . . .	1
-25	QCNW1116.A	F052140002	... HARNESS, Battery . . . . .	1
-26	QFSB1220.A	5009425001	... FUSE, Main, 0.8A, 125V, Slow Blow . . . . .	2
-27	QFSB1006.A	5009425007	... FUSE, Battery, 3A, 125V . . . . .	1
-28	QSOCA101.A	5009410002	... AC Receptacle . . . . .	1
-29	TLABZ108.B	07-26-01-085, Rev. A	... LABEL, Panel Lock & Alarm Volume . . . . .	1
-30	TLABZ109.C	07-26-A1-201	... LABEL, Battery . . . . .	1
-31	UBAT1008.A	5009480003	.. BATTERY, Lead-Acid, NPH3.2-12 . . . . .	1
-32	UBNDA100.A	F042615001	... STRAP, Power Cord . . . . .	1

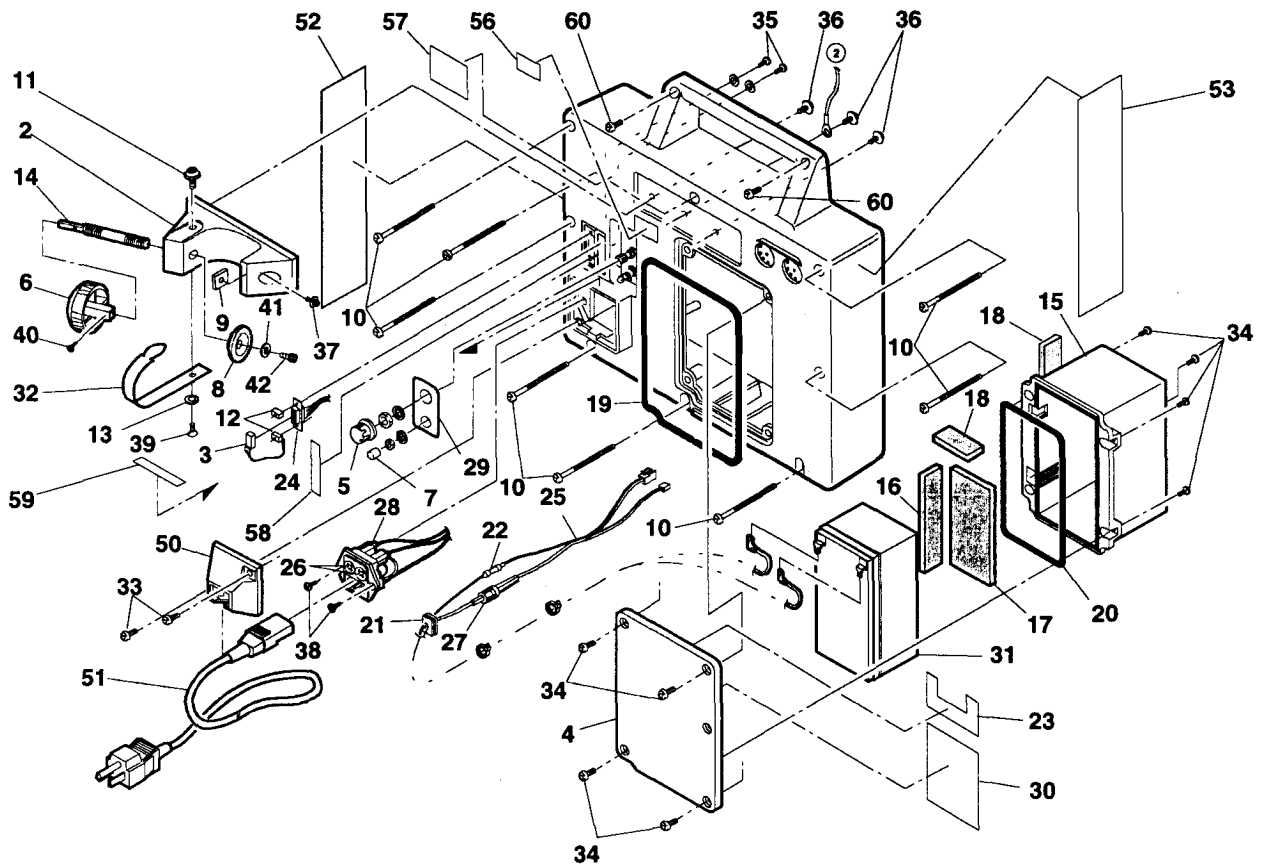

Figure 8-4. Rear Housing Assembly - External

Rear Housing Assembly - External (Figure 8-4) continued

Item	Svc. Part #	Mfg. Part #	Description	Qty
-33	XBBSD30P.B	4009310010	... SCREW, Binder Head, M3X12 . . . . .	2
-34	XBBD40P.D	4009310012	... SCREW, Binder Head, M4X10. . . . .	8
-35	XBPBN26P.A	4009310006	... SCREW, Pan Head, M2.6X8 . . . . .	2
-36	XBPBN40P.B	4009310004	... SCREW, Pan Head, M4X10 w/ washer assy . . . . .	3
-37	XBPDS30P.V	4009310008	... SCREW, Pan Head, M3X14 . . . . .	1
-38	XBSBN30P.A	4009310013	... SCREW, Flat Head, M3X10 . . . . .	2
-39	XBSUW40P.A	4009310016	... SCREW, Flat Head, M4X8 . . . . .	1
-40	XBTSN30P.A	4009310017	... SCREW, Truss, M3X8 . . . . .	1
-41	XWHUZ400.A	4009330013	...WASHER, Pole Clamp Shaft M4.5 . . . . .	1
-42	XXHUW40L.A	4009310022	... SCREW, Allen, M4X8 . . . . .	1
-50	GCOVH101.B	F043624003	.. COVER, Power Cord . . . . .	1
-51	QACCD761.D	5009410001	.. CORD, Power . . . . .	1
-52	TCAUS102.A	07-26-B1-091	.. LABEL, Caution, Japan . . . . .	1
-52A	07-26-A1-244	07-26-A1-244	.. LABEL, Caution, Sing. . . . .	1
-53	TCAUS102.B	07-26-01-090	.. LABEL, Directions for Use, Rev. A . . . . .	1
-54	Not Available		.. LABEL, UL . . . . .	1
-55	Not Available		.. LABEL, CSA . . . . .	1
-56	TLABZ100.F	07-26-01-098	.. PLATE, Serial Number, Aluminum . . . . .	1
-56a	F049810004	F049810004	.. PLATE, Serial number, Lexan . . . . .	1
-56b	F049810005	F049810005	.. FILM, Overlay , Serial Number . . . . .	1
-57	TLABZ106.C	07-27-01-018	.. LABEL, 24 Hour Service, Rev. A . . . . .	1
-58	TLABZ108.C	07-26-01-086	.. LABEL, Comm. Port . . . . .	1
-59	TLABZ110.F	07-26-01-100	.. LABEL, Fuse, Rev. A . . . . .	1
-60	XBBSD30P.C	4009310011	.. SCREW, Binder Head, M3X16 . . . . .	2



**Pump Head 1 Door Assembly (Figure 8-5)**

Item	Svc. Part #	Mfg. Part #	Description	Qty
8-5-	F059120015	F059120015	... PUMP 1, HEAD ASSY . . . . .	1
-1	F059120016	F059120016	.... DOOR, ASSEMBLY-P1 . . . . .	1
-2	CHNDP100.G	S047879	.....LATCH, Door Assy-P1 . . . . .	1
-3	JHNDP100.C	S048630	..... LATCH, Door-P1 . . . . .	1
-4	LPLTP106.A	S048440	..... PLATE, Door Latch Label . . . . .	1
-5	LXRZ1003.A	S048882	..... E-RING, Door Latch . . . . .	1
-6	MSPRC101.D	S048500	..... SPRING, Door Latch . . . . .	1
-7	OiCMP32T.H	S048896	..... WASHER, M4, 0.8T . . . . .	1
-8	OiCMP32T.L	S048897	..... WASHER, M4.2, 0.1T . . . . .	2
-9	PMAGT100.B	S048498	..... MAGNET, Door Latch . . . . .	1
-10	TLABH109.A	07-26-06-029	..... LABEL, Push . . . . .	1
-11	S050052	S050052	.... DOOR, PUMP HEAD-P1	
-12	LBSHZ101.A	S048489	.... BUMPER, Door . . . . .	2
-13	LBSHZ101.C	S048502	.... BUSHING, Door Latch . . . . .	1
-14	LPiNS101.C	S047417	.... PIN, Door Hinge . . . . .	2
-15	LPLTM106.A	S048445	.... PLATE, Safety Clamp . . . . .	1
-16	LPLTM106.C	S048644	.... COVER, Back Plate-P 1 . . . . .	1
-17	LPLTM104.C	S048493	.... PLATE, BACK . . . . .	1
-18	MSPRC101.C	S048499	.... SPRING, Back Plate . . . . .	5
-19	PAJS1002.A	S048494	.... STOP, Occlusion Detector . . . . .	2
-20	PCUSG101.A	S048504	.... BUMPER, Door . . . . .	4
-21	PZETE100.C	S048506	.... FILM, Plate Insulation . . . . .	1
-22	TLABZ110.A	07-26-01-179	.... LABEL, Flow . . . . .	1
-23	TLABZ110.G	S048657	.... LABEL, Tube Loading A, P1 . . . . .	1
-24	TLABZ110.H	S048658	.... LABEL, Tube Loading B, P1 . . . . .	1
-25	XBPSD20P.C	S048933	.... SCREW, Pan Head, M2X8 w/ washer assy . . . . .	2
-26	XBSUZ30P.A	S048987	.... SCREW, Flat Head., M3X6 . . . . .	7
-27	XBSUZ30P.F	S048966	.... SCREW, Flat Head, M3X10 . . . . .	1
-28	XBSUF30P.A	4009310014	.... SCREW, Flat Head, M3X12 . . . . .	5
-29	XXXSP30L.B	S048890	.... SCREW, Set, M3X4 . . . . .	2

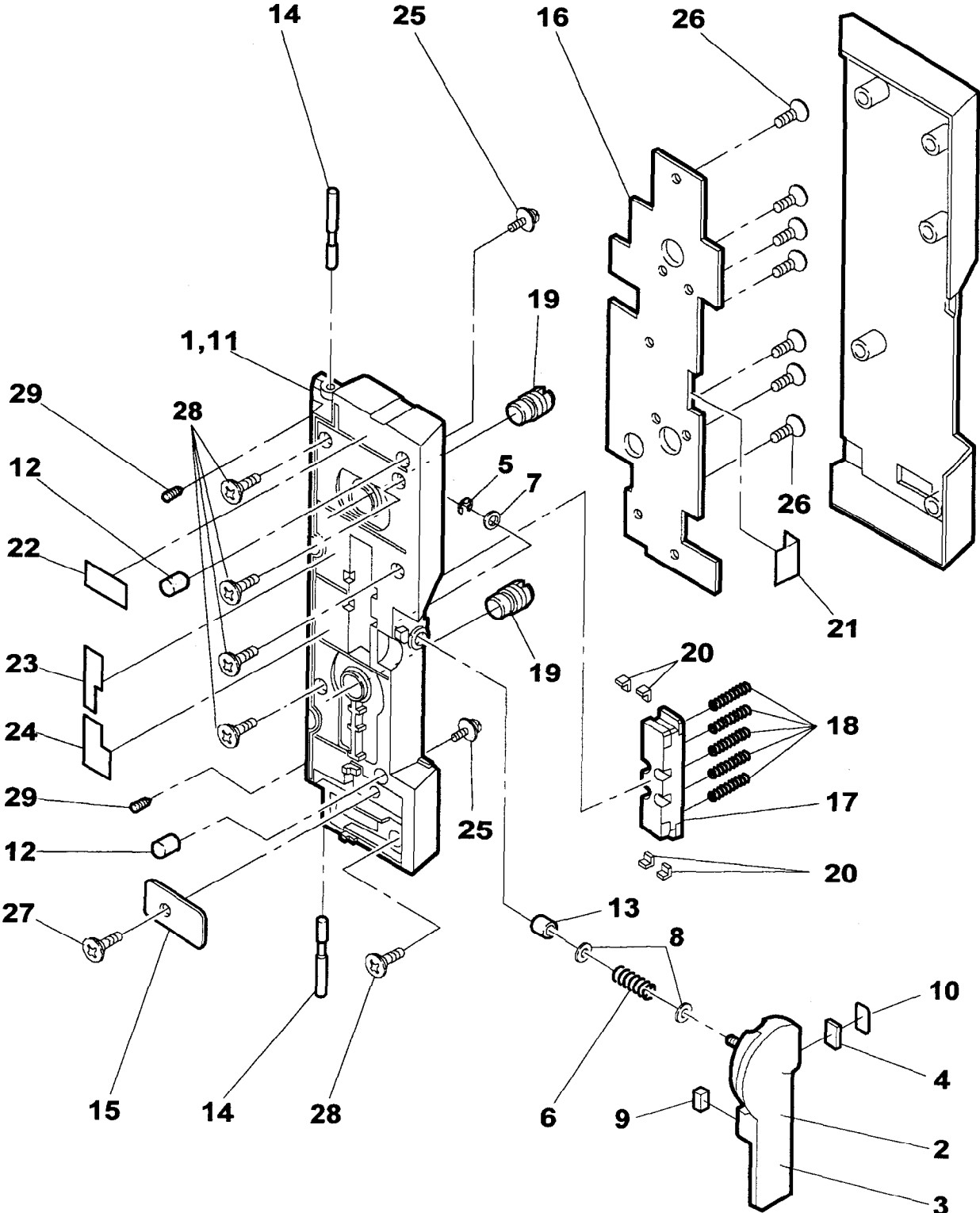

Figure 8-5. Pump Head Door Assembly

**Pump 1 Base Plate Assembly with Tube Misloading Detectors (Figure 8-6)**

Item	Svc. Part #	Mfg. Part #	Description	Qty
8-6-	F059120015	F059120015	... PUMP 1, HEAD ASSY . . . . .	1
	CPLTC106.A	S050043	.... PLATE, BASE SUB ASSY . . . . .	1
-1	LBRC1007.A	S048626	..... BLOCK, Mounting, Latch Pin-P1 . . . . .	1
-2	LBSHZ101.B	S048501	..... BUSHING, Door Hinge . . . . .	4
-3	LPiNS101.A	S048447	..... PIN, Latch . . . . .	1
-4	LPiNS101.E	S048453	..... PIN, Latch Mounting Block . . . . .	2
-5	LPLTC106.B	S048625	..... PLATE, Base-P 1 . . . . .	1
-6	LXWZ1003.A	S048873	..... WASHER, Latch Roller . . . . .	1
-7	NROLP100.A	S048455	..... ROLLER, Latch . . . . .	1
-8	PGiDM100.D	S048486	..... GUIDE, Tubing, Lower Channel . . . . .	2
-9	PGiDM100.E	S048487	..... GUIDE, Tubing Upper Channel . . . . .	3
-10	QSWZ1010.B	S047932	..... SENSOR, Tube Misload-1R . . . . .	1
-11	QSWZ1009.B	S047931	..... SENSOR, Tube Misload-1L . . . . .	1
-12	TLABZ109.D	S048650	..... DECAL, Tubing Channel-P1 . . . . .	1
-13	TLABZ109.E	S048651	..... DECAL, Tubing Channel-P1 . . . . .	1
-14	TLABZ110.E	07-26-A1-202	.... LABEL, Slide Clamp Slot, Rev. A . . . . .	1
-15	Not used			
-16	XBSSF20P.B	4009310081	..... SCREW, Flat Head, M2X5 . . . . .	2
-17	XBSUF30P.C	S048963	..... SCREW, Flat Head, M3X8 . . . . .	1
-18	PZETL102.B	S050045	.... TAPE, Conductive, Finger . . . . .	2
-19	PBOX1004.A	S048432	.... BOX, Finger . . . . .	1
-20	OiCMP32T.G	S048895	.... WASHER, M3 . . . . .	6
-21	XPBDS30P.K	S048940	.... SCREW, Pan Head, M3X8 . . . . .	6



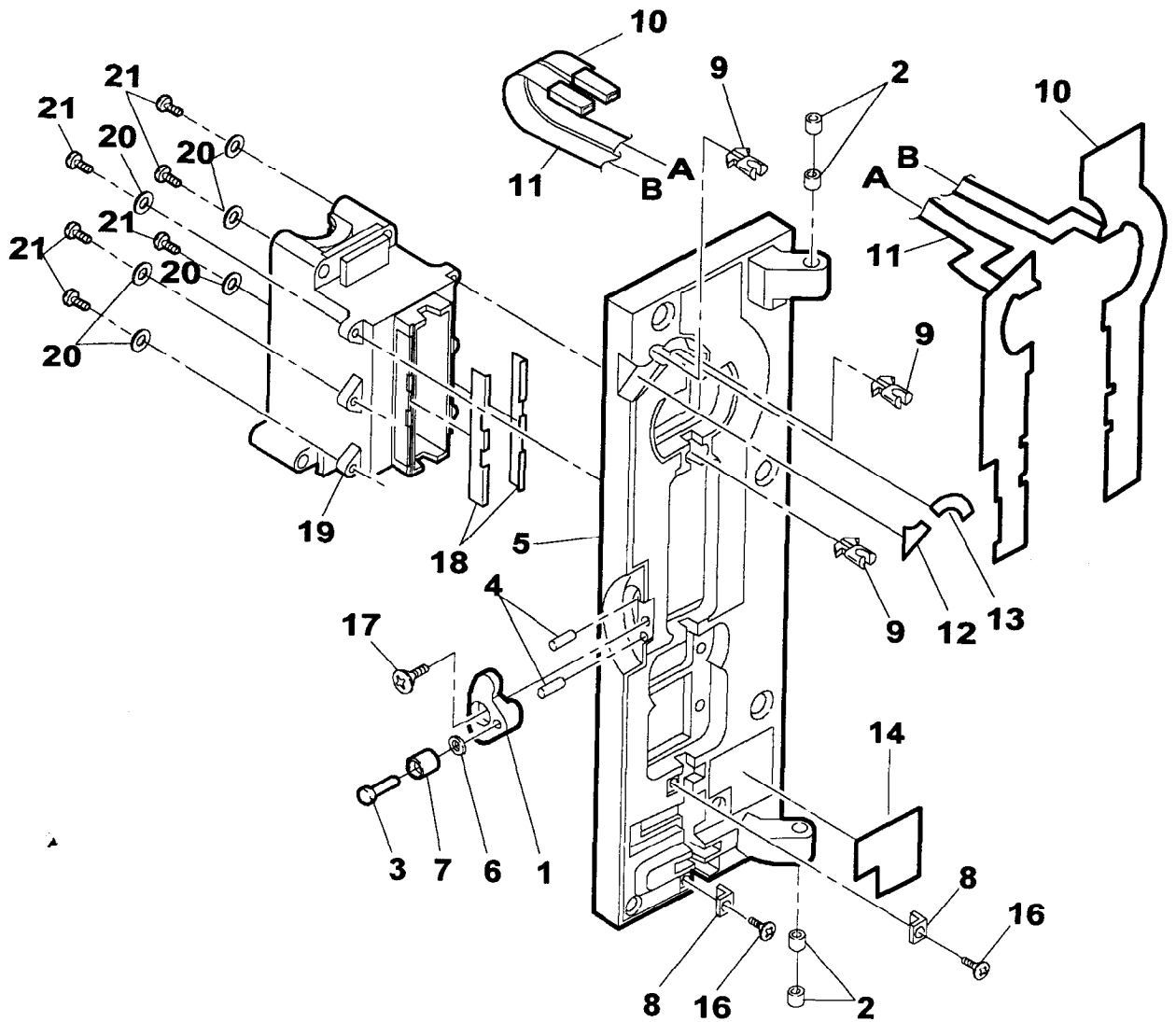

Figure 8-6. Pmp 1 Bs. Plt. w/ Tube Misloading Detectrs

**Pump 1 Base Plate Assembly-Rear (Figure 8-7)**

Item	Svc. Part #	Mfg. Part #	Description	Qty
8-7-	F059120015	F059120015	... PUMP 1 HEAD ASSY . . . . .	1
			.... PUMP 1 BASE PLATE ASSEMBLY-REAR . . . . .	1
-1	LPLTC106.B	S048625	.... PLATE, Base-P1 . . . . .	1
-2	LXBZ1020.A	S048918	.... SCREW, Flat Head, M1.7X6 . . . . .	1
-3	MSPR1001.C	S048015	.... SPRING, Downstream Occl. Sensor . . . . .	1
-4	MSPR1002.B	S048014	.... SPRING, Upstream Occl. Sensor . . . . .	1
-5	NSFTZ102.A	S048012	.... ACTUATOR, Occlusion Sensor . . . . .	2
-6	0iCMP32T.A	S048928	.... SCREW, Pan Head, M1.7X4.5 . . . . .	4
-7	0iCMP32T.E	S048893	.... WASHER, M1.7 . . . . .	2
-8	0iCMP32T.J	S048901	.... WASHER, M2 . . . . .	2
-9	PCASD100.B	S048022	.... HOUSING, Occl. Sensor . . . . .	2
-10	PCOVP101.D	S048641	.... COVER, Safety Clamp Arm-P1 . . . . .	1
-11	PZETL102.E	S048508	.... PLATE, Ground, Upstrm Occl. Sensor . . . . .	1
-12	CCILZ100.A	S048011	.... COIL, Occl. Sensor Assy . . . . .	2
-13	RCORF100.D	S048013	.... CORE, Occl. Sensor . . . . .	2
-14	S048992	S048992	.... SENSOR, AIR, ASSY-P1 . . . . .	1
-15	TLABH109.B	07-26-01-088	.... LABEL, Safety Clamp, Rev. A . . . . .	1
-16	XBSUF20P.A	S048962	.... SCREW, Flat Head, M2X10 . . . . .	6

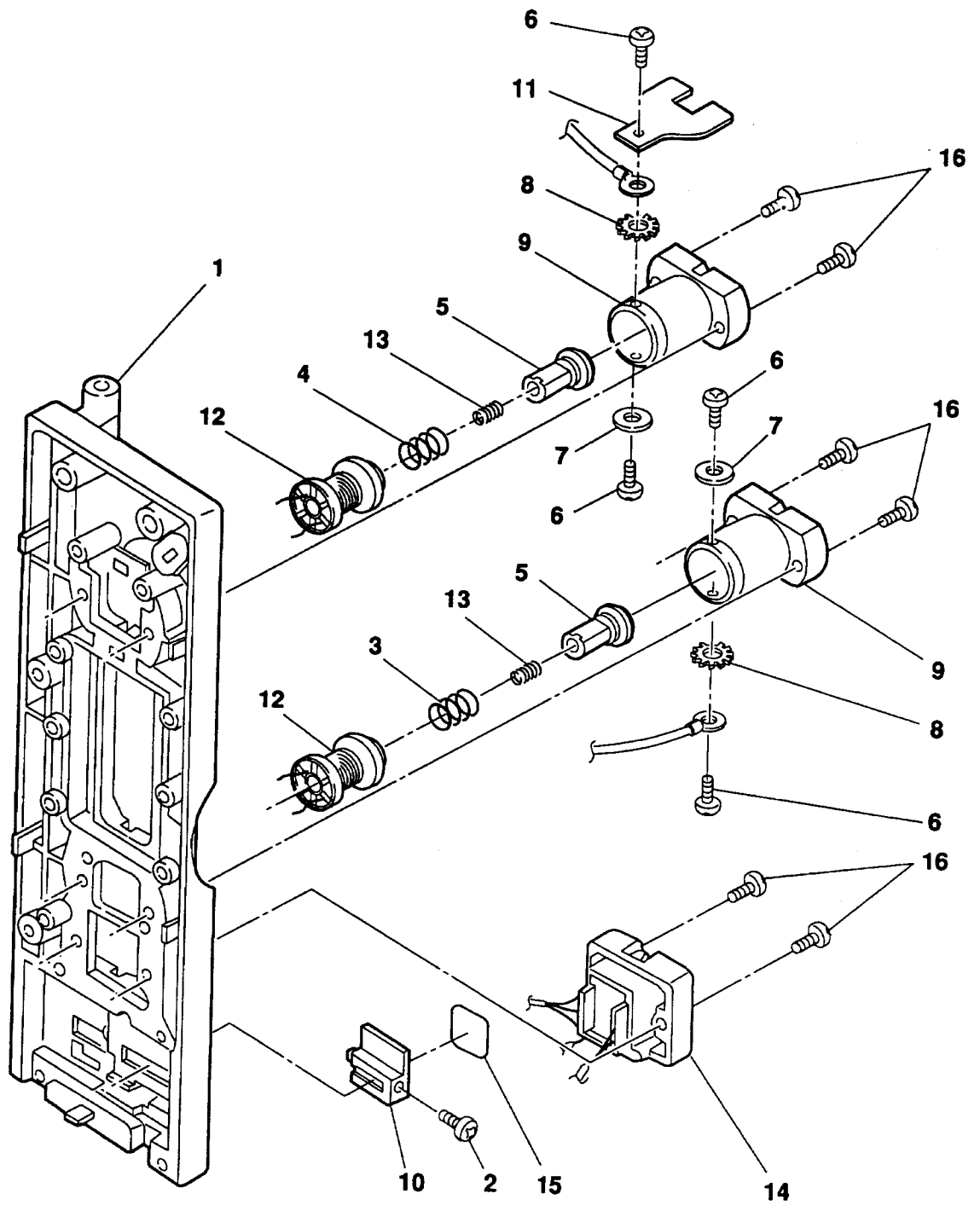

Figure 8-7. Pump 1 Base Plate Assembly - Rear

**Pump 1 Base Plate Assembly w/ Pump Mechanism (Figure 8-8)**

Item	Svc. Part #	Mfg. Part #	Description	Qty
8-8-	F059120015	F059120015	... PUMP 1, HEAD ASSY . . . . .	1
-1	CCRA1005.A	S047780	.... CLAMP, SAFETY SLIDE ASSEMBLY 1 . . . . .	1
<b>Note: See Figure 8-9 for details on item 1.</b>				
-2	LBRC1006.A	S048426	.... RETAINER, Motor Spring . . . . .	1
-3	LBSHZ101.D	S048497	.... STOPPER, Cam . . . . .	1
-4	LPLTM104.D	S048488	.... WHEEL, Encoder . . . . .	1
-5	LPLTP104.A	S048484	.... FINGER, #1,2,7,8 . . . . .	4
-6	LPLTP104.B	S048485	.... FINGER, #3,4,5,6 . . . . .	4
-7	MCAMP100.A	S048483	.... CAM . . . . .	8
-8	MJNTM100.B	S048454	.... COUPLING, Motor . . . . .	1
-9	MSPRD102.A	S048471	.... SPRING, Motor . . . . .	2
-10	NBRGY100.B	S048511	.... BEARING, Pumping Finger . . . . .	9
-11	NBRGY100.C	S048512	.... BEARING, Finger Box . . . . .	1
-12	NSFTD103.A	S048433	.... SHAFT, Finger . . . . .	1
-13	OiCMP32T.F	S048894	.... WASHER, Optocoplr, PCB . . . . .	2
-14	OiCMP32T.G	S048895	....WASHER, M3 . . . . .	4
-15	PBOX1005.A	S048431	.... COVER, Finger Box . . . . .	1
-16	PCOVP101.B	S048427	.... COVER, Encoder Wheel . . . . .	1
-17	PSPAB102.A	S048496	.... SPACER, Encoder Wheel . . . . .	1
-18	CPBWM105.B	S047876	.... PCB, ASSEMBLY-Optocoupler . . . . .	1
-19	VHPGP32S.B	S048016	.... OPTOCOPLR . . . . .	1
-20	RMOTP100.B	S048510	.... MOTOR . . . . .	1
-21	XBPSD30P.D	4009310005	.... SCREW, Pan Head, M3X6 . . . . .	1
-22	XBPSD30P.U	S048947	.... SCREW, Pan Hd., M3X55 . . . . .	4
-23	XJPSF20P.A	S048955	.... SCREW, Pan Hd., M2X6 . . . . .	4
-24	XWSSD200.A	S048879	.... WASHER, Spring, Optocoupler PCB . . . . .	2
-25	XWSSD300.B	S048899	.... WASHER, M3 . . . . .	4
-26	XXXSP30L.A	S048876	.... SCREW, M3X3 . . . . .	2
-27	XXXSP30L.B	S048890	.... SCREW, Set, M3X4 . . . . .	4
-28	XBPSD30P.W	4009310042	.... SCREW, Pan Head, M3X10 w/ washer assy . . . . .	4
-29	Not used			
-30	LANGT103.A	S048446	.... BRACKET, Fixing, Door Sw PCB . . . . .	1

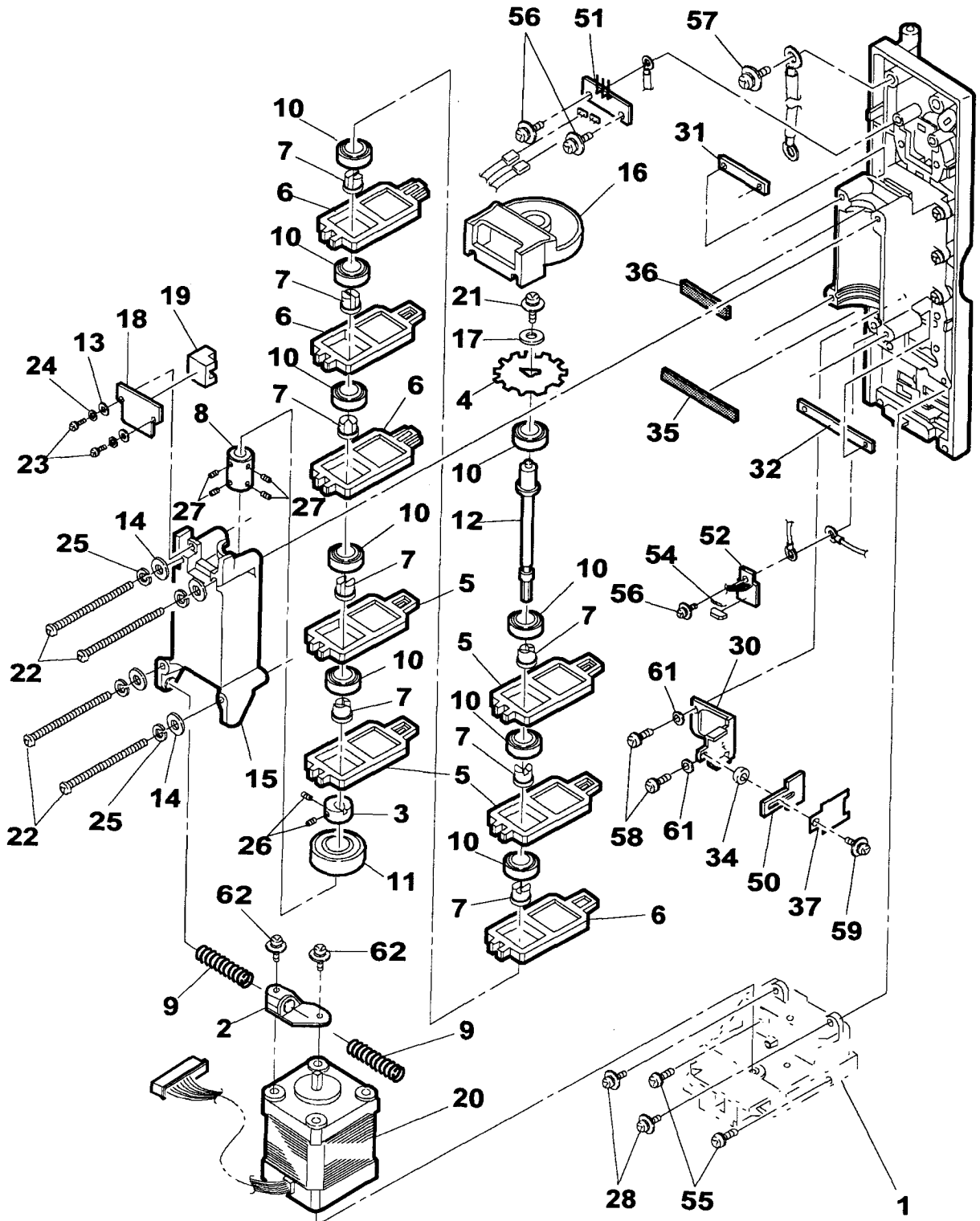

Figure 8-8. Pump 1 Bs. Plt. Assmly w/ Pump Mechanism

**Pump 1 Base Plate Assembly w/ Pump Mechanism (Figure 8-8) continued**

Item	Svc. Part #	Mfg. Part #	Description	Qty
-31	LFiX1011.A	S048443	.... NUT BAR, Finger box Top . . . . .	1
-32	LFiX1012.A	S048444	.... NUT BAR, Finger box Btm . . . . .	1
-33	Not used			
-34	PSPA1020.A	S048746	.... SPACER, Door Sw PCB . . . . .	1
-35	PSPAZ101.A	S048490	.... RETAINER, Rubber, Bottom Bearing . . . . .	1
-36	PSPAZ101.B	S048491	.... RETAINER, Rubber, Top Bearing . . . . .	1
-37	PZETL101.A	S048462	.... FILM, Door Switch PCB Insulation . . . . .	1
<b>The following wire harnesses are not shown.</b>				
-40	QCNW1097.A	S048473	.... HARNESS, Tube Misload Detector . . . . .	1
-41	QCNW1098.A	S048474	.... HARNESS, Slide Clamp Sensor . . . . .	1
-42	QCNW1099.A	S048475	.... HARNESS, Slide Clamp Sensor 1 ext. . . . .	1
-43	QCNW1100.A	S048476	.... HARNESS, Optocoupler PCB . . . . .	1
-44	QCNW1119.A	S048652	.... HARNESS, Door Sw PCB, P1 . . . . .	1
-45	QCNW1120.A	S048653	.... HARNESS, Upstream Occl. Sensor-P1 . . . . .	1
-46	QCNW1121.A	S048654	.... HARNESS, Downstream Occl. Sensor-P1 . . . . .	1
-47	QCNW1122.A	S048655	.... HARNESS, Air Sensor Input, P1 . . . . .	1
-48	QCNW1123.A	S048656	.... HARNESS, Air Sensor Output, P1 . . . . .	1
-50	QPWBN103.B	S048492	.... PCB, Door Open Sw . . . . .	1
-51	QPWBN105.A	S048459	.... PCB, Tube Misload Terminal . . . . .	1
-52	CPWBN106.A	S048624	.... PCB, Flexible Prntd Crkt Terminal . . . . .	1
-53	QSWL1003.C	S048513	.... SWITCH, Door Open . . . . .	1
-54	VRDRV2EY.A	S048521	.... RESISTOR, 100 Ohms . . . . .	2
-55	XBBSD30P.D	4003910075	.... SCREW, Binder Head, M3X8 . . . . .	2
-56	XBPNB30P.C	S048929	.... SCREW, Pan Head, M3X8 . . . . .	2
-57	XBPNB40P.F	4009310080	.... SCREW, Pan Head, M4X6 . . . . .	1
-58	XBPSD20P.A	S048923	.... SCREW, Pan Head, M2X5 . . . . .	2
-59	XBPSD26P.B	S048933	.... SCREW, Pan Head, M2.5X8 . . . . .	1
-60	Not used			
-61	XWHSD200.A	S048891	.... WASHER, Door Open Sw PCB Bracket . . . . .	2
-62	XBPSD30P.i	S048939	.... Screw, Pan Hd., M3X8 . . . . .	2

**Safety/Slide Clamp Assembly 1 (Figure 8-9)**

Item	Svc. Part #	Mfg. Part #	Description	Qty
8-9-	F059120015	F059120015	... PUMP 1, HEAD ASSY . . . . .	1
	CCRA1005.A	S047780	.... CLAMP, SAFETY SLIDE ASSEMBLY P1 . . . . .	1
-1	LCHSM100.E	S048636	..... HOUSING, Upper, P1 . . . . .	1
-2	LCHSM100.F	S048637	..... HOUSING, Lower, P1 . . . . .	1
-3	LCHSM100.G	S048643	..... HOUSING, Slide Clamp, Sensor 1 . . . . .	1
-4	LCHSM100.D	S048439	..... HOUSING, Slide Clamp, Sensor 2 . . . . .	1
-5	LCRA1005.A	S048638	..... CLAMP, Safety, P1 . . . . .	1
-6	LPiNS101.B	S048448	..... PIN, Release . . . . .	1
-7	LPiNS101.F	S048986	..... PIN, Dowel, Slide A . . . . .	1
-8	LPLTP107.B	S048639	..... PLATE, Motor Holding, P1 . . . . .	1
-9	LXRZ1002.A	S048881	..... E-RING, Shaft . . . . .	3
-10	MARMP100.E	S048632	..... ARM, Left Retainer, P1 . . . . .	1
-11	MARMP100.D	S048631	..... ARM, Right Retainer, P1 . . . . .	1
-12	MARMP100.F	S048642	..... ARM, Release, P1 . . . . .	1
-13	MCAMP100.C	S048640	..... LATCH, Safety, P1 . . . . .	1
-14	MSLiZ100.A	S048425	..... SLIDE A . . . . .	1
-15	MSLiZ100.C	S048633	..... LATCH, Slide, P1 . . . . .	1
-16	MSPRC101.D	S048500	..... SPRING, Slide Latch . . . . .	1
-17	MSPRD102.B	S048470	..... SPRING, Retainer Arms . . . . .	2
-18	MSPRD102.C	S048472	..... SPRING, Slide Shaft . . . . .	1
-19	MSPRD102.D	S048469	..... SPRING, Safety Clamp . . . . .	1
-20	MSPRP102.A	S048642	..... SPRING, Flat, Slide Shaft . . . . .	1
-21	NSFTD103.B	S048449	..... SHAFT, Slide . . . . .	1
-22	LPiND101.D	S048450	..... PIN, Release . . . . .	1
-23	NSFTD103.C	S048451	..... SHAFT, Safety Latch . . . . .	1
-24	NSFTD103.D	S048452	..... SHAFT, Safety Clamp . . . . .	1
-25	PSLDP100.C	S048645	..... SEAL, Safety Clamp, P1 . . . . .	1
-26	PZETL101.B	S048464	..... FILM, Insulation, PCB . . . . .	1
-27	PZETL102.D	3004010007	..... FILM, FPC Insulation, P1 . . . . .	1
-28	CPWBN105.E	S050074	..... PCB, Slide Clamp, Sensor 2, P1 . . . . .	1
-29	QPWBN105.D	S048648	..... FLXBL PC, Slide Clamp, Sensor 1, P1 . . . . .	1
-30	XBPSD30P.i	S048939	..... SCREW, Pan Head, M3X8 w/ washer assy . . . . .	2

**Safety/Slide Clamp Assembly 1 (Figure 8-9) continued**

---

<b>Item</b>	<b>Svc. Part #</b>	<b>Mfg. Part #</b>	<b>Description</b>	<b>Qty</b>
-31	XBSSD30P.B	S048960	..... SCREW, Flat Head, M3X10 . . . . .	2
-32	XBSUF20P.C	S048967	..... SCREW, Flat Head, M2X6 . . . . .	1
-33	XJPSD30P.A	S048953	..... SCREW, Pan Head, M2X6 . . . . .	1
-34	XJPSF20P.B	S048954	..... SCREW, Pan Head, M2X4 . . . . .	2
-35	XJPSF20P.A	S048955	..... SCREW, Pan Head, M2X6 . . . . .	2



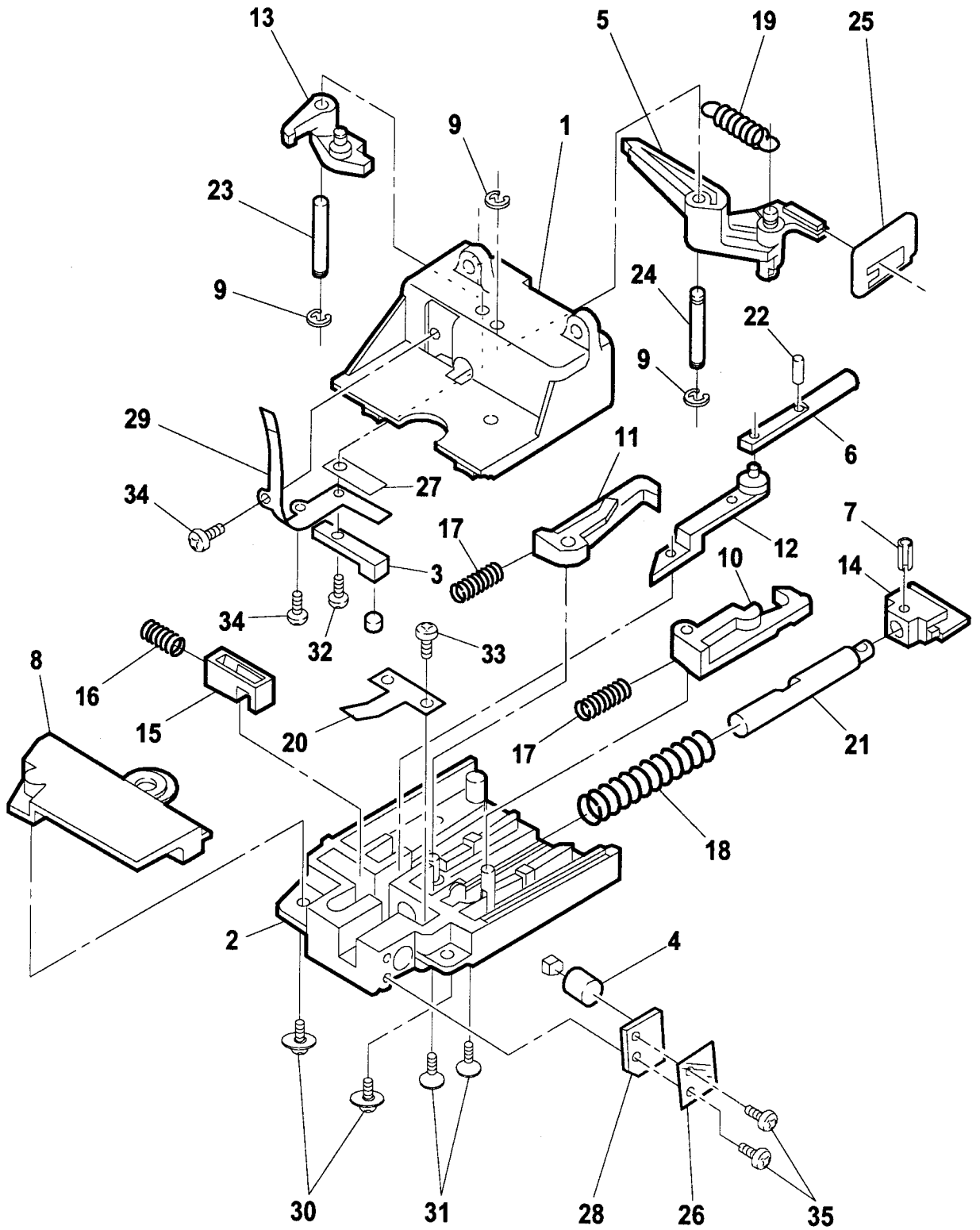

Figure 8-9. Safety/Slide Clamp Assembly I

**Pump Head 2 Door Assembly (Figure 8-10)**

Item	Svc. Part #	Mfg. Part #	Description	Qty
8-10-	F049120020	F049120020	... PUMP 2, HEAD ASSY . . . . .	1
-1	F049120021	F049120021	.... DOOR, ASSEMBLY-P2 . . . . .	1
-2	CHNDP100.F	S047944	..... LATCH, Door Assy-P2 . . . . .	1
-3	JHNDP100.B	S048021	..... LATCH, Door-P2 . . . . .	1
-4	LPLTP106.A	S048440	..... PLATE, Door Latch Label . . . . .	1
-5	LXRZ1003.A	S048882	..... E-RING, Door Latch . . . . .	1
-6	MSPRC101.D	S048500	..... SPRING, Door Latch . . . . .	1
-7	OiCMP32T.H	S048896	..... WASHER, M4, 0.8T . . . . .	1
-8	OiCMP32T.L	S048897	..... WASHER, M4.2, 0.1T . . . . .	2
-9	PMAGT100.B	S048498	..... MAGNET, Door Latch . . . . .	1
-10	TLABH109.A	07-26-06-029	..... LABEL, Push . . . . .	1
-11	S050051	S050051	.... DOOR, PUMP HEAD-P2 . . . . .	1
-12	LBSHZ101.A	S048489	.... BUMPER, Door . . . . .	2
-13	LBSHZ101.C	S048502	.... BUSHING, Door latch . . . . .	1
-14	LPiNS101.C	S047417	.... PIN, Door Hinge . . . . .	2
-15	LPLTM106.A	S048445	.... PLATE, Safety Clamp . . . . .	1
-16	LPLTM106.B	S048441	.... COVER, Back Plate-P2 . . . . .	1
-17	LPLTM104.C	S048493	.... PLATE, BACK . . . . .	1
-18	MSPRC101.C	S048499	.... SPRING, Back Plate . . . . .	5
-19	PAJS1002.A	S048494	.... STOP, Occlusion Detector . . . . .	2
-20	PCUSG101.A	S048504	.... BUMPER, Door . . . . .	4
-21	PZETE100.C	S048506	.... FILM, Plate Insulation . . . . .	1
-22	TLABZ110.A	07-26-01-179	.... LABEL, Flow . . . . .	1
-23	TLABZ110.B	S047929	.... LABEL, Tube Loading A, P2 . . . . .	1
-24	TLABZ110.C	S047930	.... LABEL, Tube Loading B, P2 . . . . .	1
-25	XBPSD20P.C	S048933	.... SCREW, Pan Head, M2X8 w/ washer assy . . . . .	2
-26	XBSUZ30P.A	S048987	.... SCREW, Flat Head, M3X6 . . . . .	7
-27	XBSUZ30P.F	S048966	.... SCREW, Flat Head, M3X10 . . . . .	1
-28	XBSUF30P.A	4009310014	.... SCREW, Flat Head, M3X12 . . . . .	5
-29	XXXSP30L.B	S048890	.... SCREW, Set, M3X4 . . . . .	2

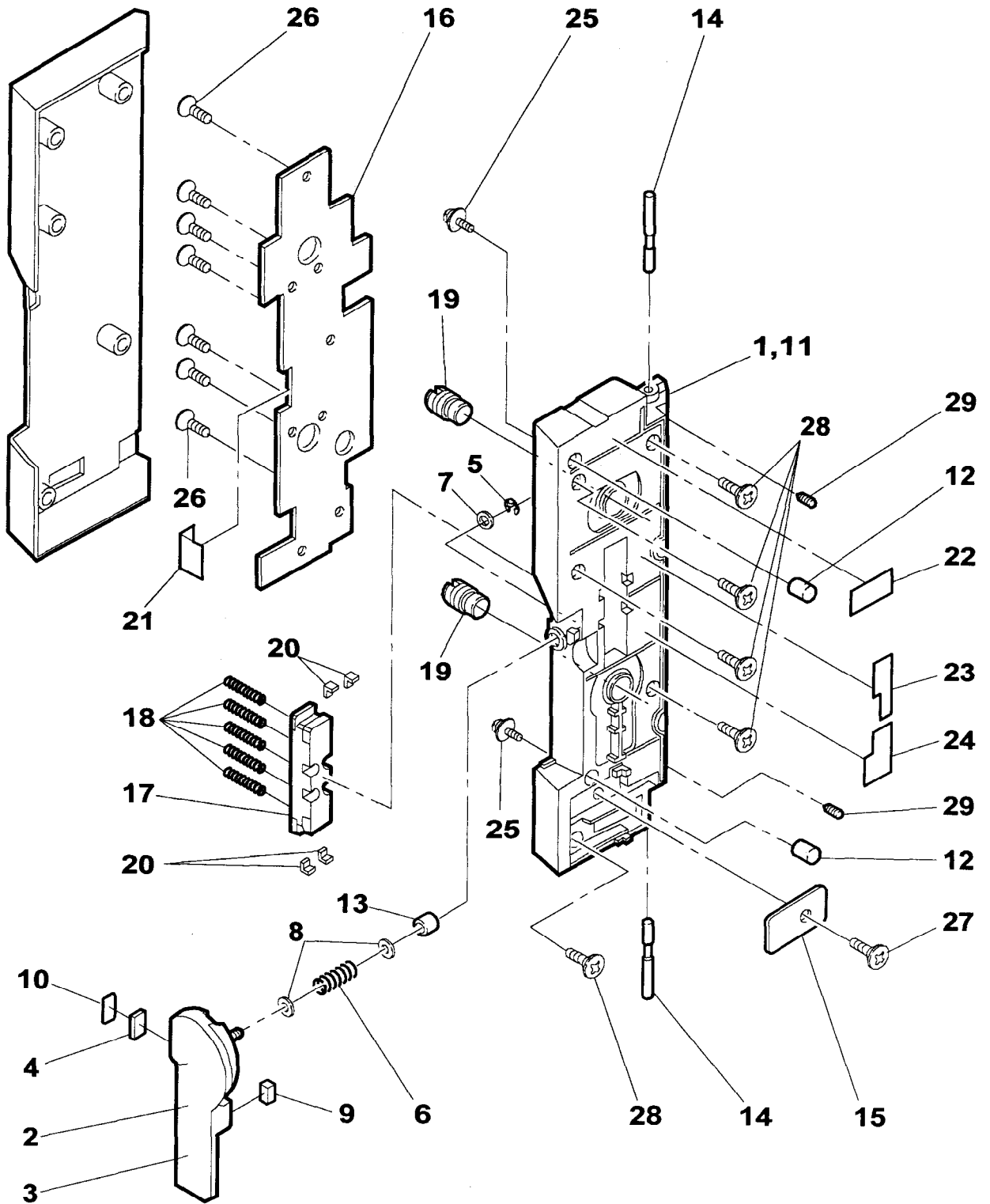

Figure 8-10. Pump Head 2 Door Assembly

**Pump 2 Base Plate Assembly w/ Tube Misloading Detectors (Figure 8-11)**

Item	Svc. Part #	Mfg. Part #	Description	Qty
8-11-	F049120020	F049120020	... PUMP 2, HEAD ASSY . . . . .	1
	CPLTC106.A	S050044	... PLATE, BASE, SUB ASSY-P2 . . . . .	1
-1	LBRC1008.A	S048018	..... BLOCK, Mounting, Latch Pin-P2 . . . . .	1
-2	LBSHZ101.B	S048501	..... BUSHING, Door Hinge . . . . .	4
-3	LPiNS101.A	S048447	..... PIN, Latch . . . . .	1
-4	LPiNS101.E	S048453	..... PIN, Latch Mounting Block . . . . .	2
-5	LPLTC106.A	S048017	..... PLATE, Base-P2 . . . . .	1
-6	LXWZ1003.A	S048873	..... WASHER, Latch Roller . . . . .	1
-7	NROLP100.A	S048455	..... ROLLER, Latch . . . . .	1
-8	PGiDM100.D	S048486	..... GUIDE, Tubing, Lower Channel . . . . .	2
-9	PGiDM100.E	S048487	..... GUIDE, Tubing, Upper Channel . . . . .	3
-10	QSWZ1011.B	S047933	..... SENSOR, Tube Misload-2L . . . . .	1
-11	QSWZ1012.B	S047934	..... SENSOR, Tube Misload-2R . . . . .	1
-12	TLABZ109.A	S048465	..... DECAL, Tubing Channel-P2 . . . . .	1
-13	TLABZ109.B	S048466	..... DECAL, Tubing Channel-P2 . . . . .	1
-14	TLABZ110.E	07-26-A1-202	..... LABEL, Slide Clamp Slot , Rev. A . . . . .	1
-15	Not used			
-16	XBSSF20P.B	4009310081	..... SCREW, Flat Head, M2X5 . . . . .	2
-17	XBSUF30P.C	S048963	..... SCREW, Flat Head, M3X8 . . . . .	1
-18	PZETL102.B	S050045	..... TAPE, Conductive, Finger . . . . .	2
-19	PBOX1004.A	S048432	..... BOX, Finger . . . . .	1
-20	OiCMP32T.G	S048895	.....WASHER, M3 . . . . .	6
-21	XBPSD30P.K	S048940	.....SCREW, Pan Head, M3X8 . . . . .	6

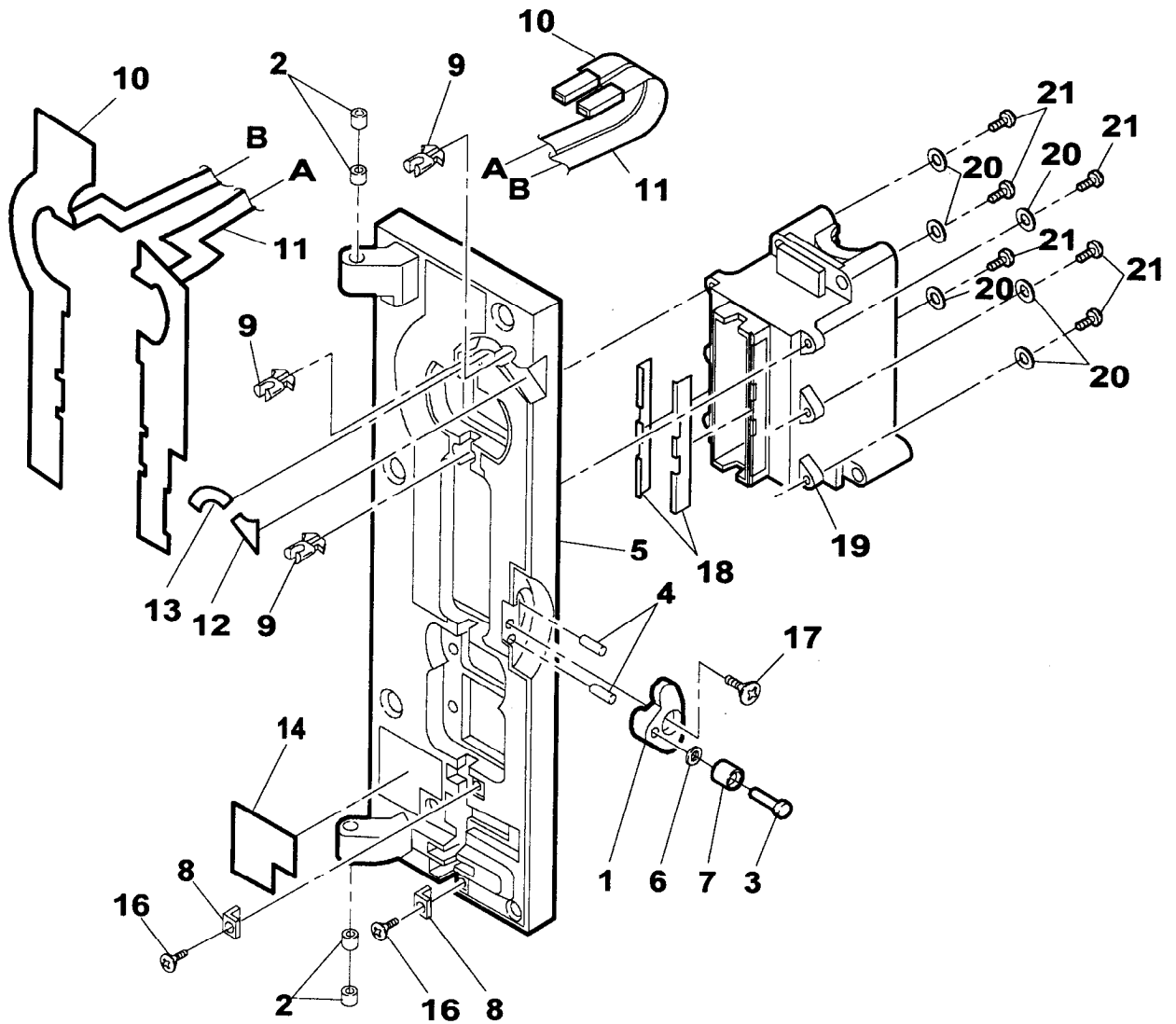

Figure 8-11. Pmp 2 Bs. Plt. w/ Tube Misloading Detectrs

**Pump 2 Base Plate Assembly - Rear (Figure 8-12)**

Item	Svc. Part #	Mfg. Part #	Description	Qty
8-12-	F049120020	F049120020	... PUMP 2, HEAD ASSY . . . . .	1
			.... PUMP 2 BASE PLATE ASSEMBLY-REAR . . . . .	1
-1	LPLTC106.A	S048017	.... PLATE, Base, P2 . . . . .	1
-2	LXBZ1020.A	S048918	.... SCREW, Flat Head, M1.7X6 . . . . .	1
-3	MSPR1001.C	S048015	.... SPRING, Downstream Occl. Sensor . . . . .	1
-4	MSPR1002.B	S048014	.... SPRING, Upstream Occl. Sensor . . . . .	1
-5	NSFTZ102.A	S048012	.... ACTUATOR, Occl. Sensor . . . . .	2
-6	OiCMP32T.A	S048928	.... SCREW, Pan Head, M1.7X4.5 . . . . .	4
-7	OiCMP32T.E	S048893	.... WASHER, M1.7 . . . . .	2
-8	OiCMP32T.J	S048901	.... WASHER, M2 . . . . .	2
-9	PCASD100.B	S048022	.... HOUSING, Occl. Sensor . . . . .	2
-10	PCOVP101.C	S048436	.... COVER, Safety Clamp Arm P2 . . . . .	1
-11	PZETL102.E	S048508	.... PLATE, Ground, Upstrm. Occl. Sensor . . . . .	1
-12	CCILZ100.A	S048011	.... COIL, Occl. Sensor Assy . . . . .	2
-13	RCORF100.D	S048013	.... CORE, Occl. Sensor . . . . .	2
-14	S048993	S048993	.... SENSOR, AIR, ASSY-P2 . . . . .	1
-15	TLABH109.B	07-26-01-088	.... LABEL, Safety Clamp, Rev. A . . . . .	1
-16	XBSUF20P.A	S048962	.... SCREWS, Flat Head, M2X10 . . . . .	6

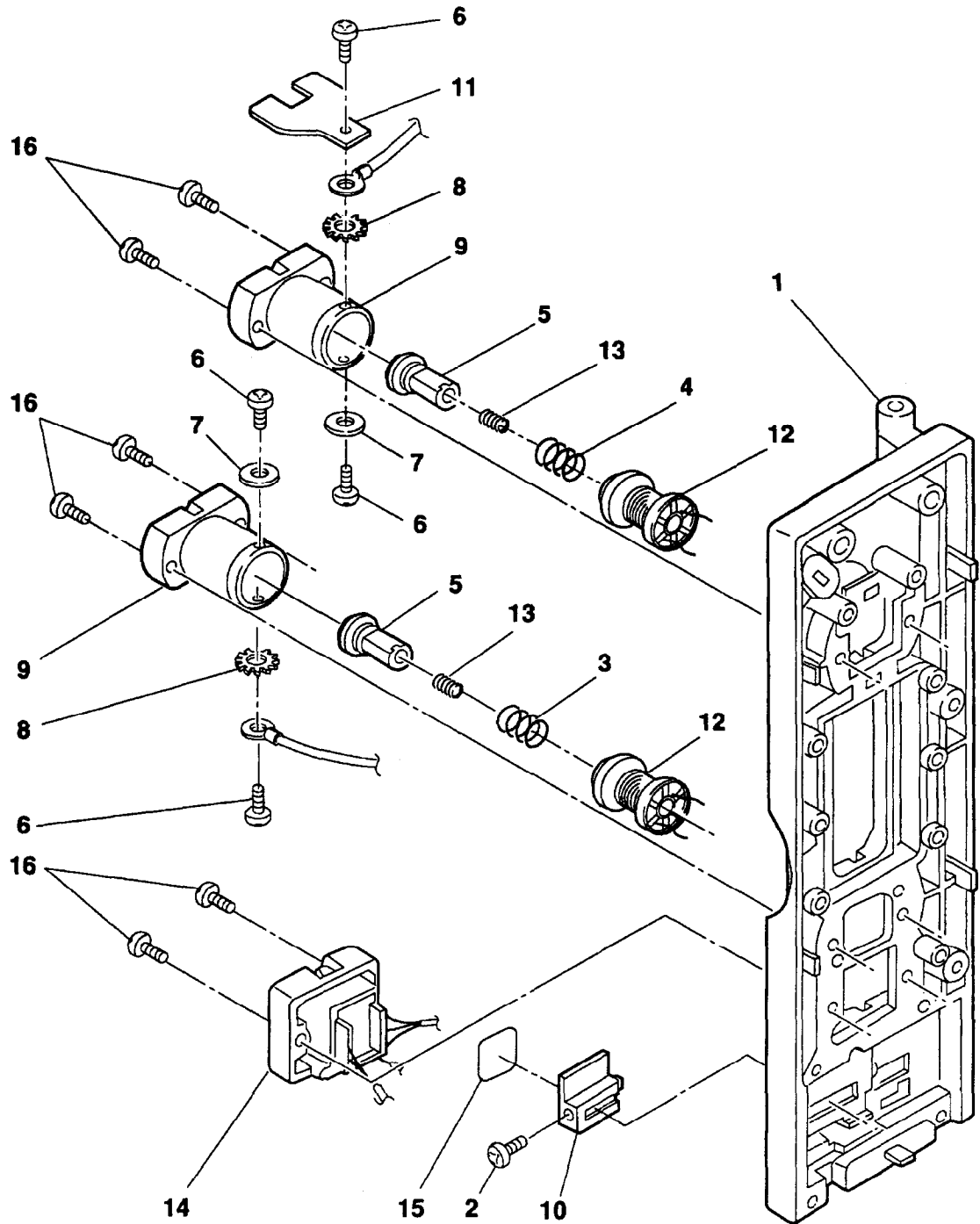

Figure 8-12. Pump 2 Base Plate Assembly-Rear

**Pump 2 Base Plate Assembly w/ Pump Mechanism (Figure 8-13)**

Item	Svc. Part #	Mfg. Part #	Description	Qty
8-13-	F049120020	F049120020	... PUMP 2, HEAD ASSY . . . . .	1
<b>Note:</b>	<b>See Figure 8-13 for details on items 1 through 30.</b>			
-1	CCRA1006.A	S047875	.... CLAMP, SAFETY SLIDE ASSEMBLY 2 . . . . .	1
-2	LBRC1006.A	S048426	.... RETAINER, Motor Spring . . . . .	1
-3	LBSHZ101.D	S048497	.... STOPPER, Cam . . . . .	1
-4	LPLTM104.D	S048488	.... WHEEL, Encoder . . . . .	1
-5	LPLTP104.A	S048484	.... FINGER, #1,2,7,8 . . . . .	4
-6	LPLTP104.B	S048485	.... FINGER, #3,4,5,6 . . . . .	4
-7	MCAMP100.A	S048483	.... CAM . . . . .	8
-8	MJNTM100.B	S048454	.... COUPLING, Motor . . . . .	1
-9	MSPRD102.A	S048471	.... SPRING, Motor . . . . .	2
-10	NBRGY100.B	S048511	.... BEARING, Pumping Finger . . . . .	9
-11	NBRGY100.C	S048512	.... BEARING, Finger Box . . . . .	1
-12	NSFTD103.A	S048433	.... SHAFT, Finger . . . . .	1
-13	OiCMP32T.F	S048894	.... WASHER, Optocoplr, PCB . . . . .	2
-14	OiCMP32T.G	S048895	.... WASHER, M3 . . . . .	4
-15	PBOX1005.A	S048431	.... COVER, Finger Box . . . . .	1
-16	PCOVPI01.B	S048427	.... COVER, Encoder Wheel . . . . .	1
-17	PSPAB102.A	S048496	.... SPACER, Encoder Wheel . . . . .	1
-18	CPBWM105.B	S047876	.... PCB, ASSEMBLY- Optocoupler . . . . .	1
-19	VHPGP3S2.A	S048016	.... OPTOCOPLR . . . . .	1
-20	RMOTP100.B	S048510	.... MOTOR . . . . .	1
-21	XBPSD30P.D	4009310005	.... SCREW, Pan Head, M3X6 . . . . .	1
-22	XBPSD30P.U	S048947	.... SCREW, Pan Head, M3X55 . . . . .	4
-23	XJPSF20P.A	S048955	.... SCREW, Pan Head, M2X6 . . . . .	4
-24	XWSSD200.A	S048879	.... WASHER, Spring, Optocoupler PCB . . . . .	2
-25	XWSSD300.B	S048899	.... WASHER, M3 . . . . .	4
-26	XXXSP30L.A	S048876	.... SCREW, M3X3 . . . . .	2
-27	XXXSP30L.B	S048890	.... SCREW, Set, M3X4 . . . . .	4
-28	XBPSD30P.W	4009310042	.... SCREW, Pan Head, M3X10 . . . . .	1
-29	Not used			
-30	LANGT103.A	S048446	.... BRACKET, Fixing, Door Sw PCB . . . . .	1



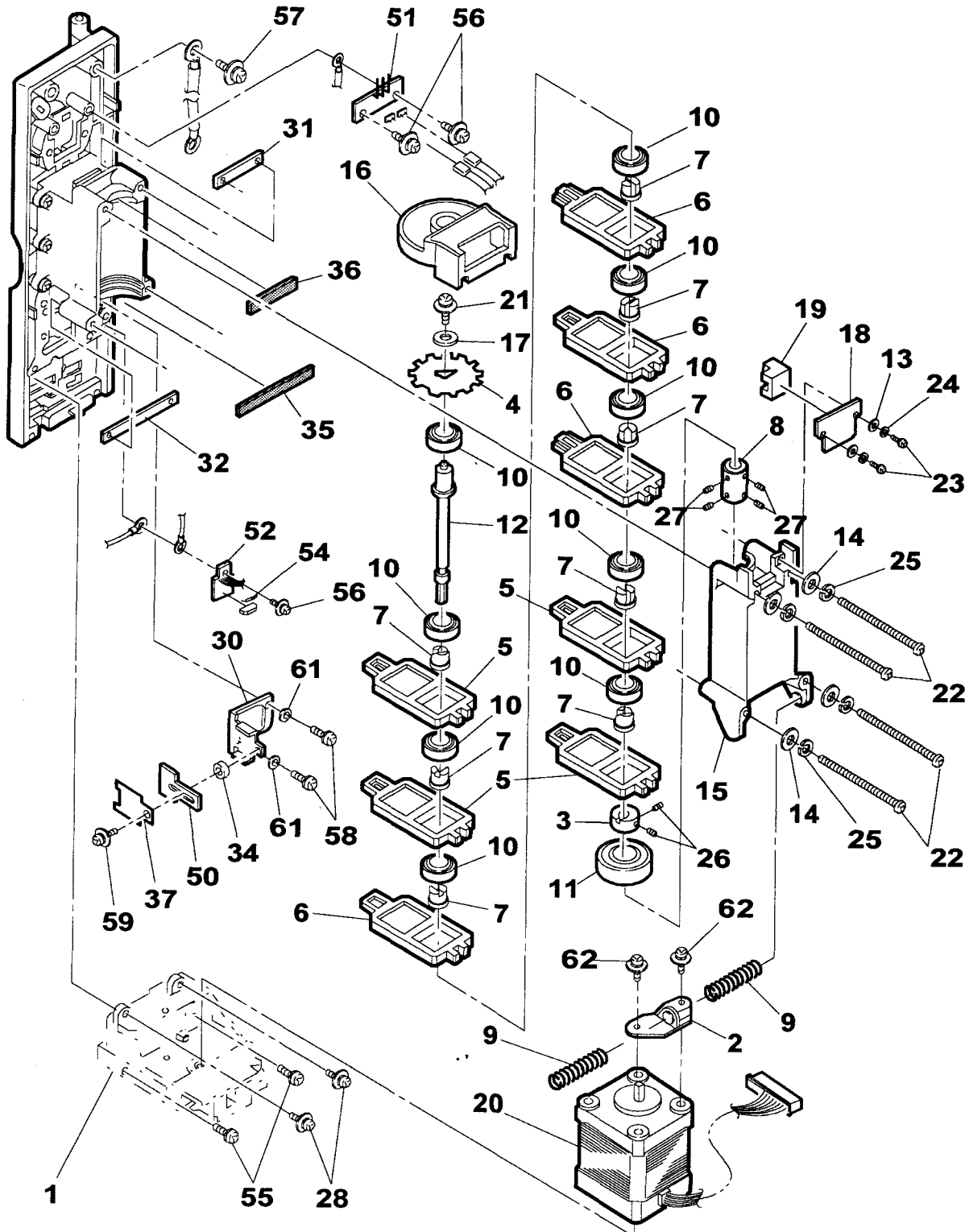

Figure 8-13. Pump 2 Bs. Plt. Assmly w/ Pump Mechanism

**Pump 2 Base Plate Assembly w/ Pump Mechanism (Figure 8-13) continued**

Item	Svc. Part #	Mfg. Part #	Description	Qty
-31	LFiX1011.A	S048443	.... NUT BAR, Finger Box Top . . . . .	1
-32	LFiX1012.A	S048444	.... NUT BAR, Finger Box Btm . . . . .	1
-33	Not used			
-34	PSPA1020.A	S048746	.... SPACER, Door Sw PCB . . . . .	1
-35	PSPAZ101.A	S048490	.... RETAINER, Rubber, Bottom Bearing . . . . .	1
-36	PSPAZ101.B	S048491	.... RETAINER, Rubber, Top Bearing . . . . .	1
-37	PZETL101.A	S048462	.... FILM, Door Switch PCB Insulation . . . . .	1
<b>Note:</b>	<b>The following wire harnesses are not shown.</b>			
-40	QCNW1097.A	S048473	.... HARNESS, Tube Misload Detector . . . . .	1
-41	QCNW1098.A	S048474	.... HARNESS, Slide Clamp Sensor 1 OR 2 . . . . .	1
-42	QCNW1099.A	S048475	.... HARNESS, Slide Clamp Sensor 1 OR 2 ext . . . . .	1
-43	QCNW1100.A	S048476	.... HARNESS, Optocoupler PCB . . . . .	1
-44	QCNW1101.A	S048477	.... HARNESS, Door Sw PCB-P2 . . . . .	1
-45	QCNW1102.A	S048478	.... HARNESS, Upstream Occl. Sensor-P2 . . . . .	1
-46	QCNW1103.A	S048479	.... HARNESS, Downstream Occl. Sensor-P2 . . . . .	1
-47	QCNW1104.A	S048480	.... HARNESS, Air Sensor Input-P2 . . . . .	1
-48	QCNW1105.A	S048481	.... WIRE HARNESS, Air Sensor Output-P2 . . . . .	1
-50	QPWBN103.B	S048492	.... PCB, Door Open Sw . . . . .	1
-51	QPWBN105.A	S048459	.... PCB, Tube Misload Terminal . . . . .	1
-52	CPWBN105.B	S047877	.... PCB, Flexible Prntd Crkt Terminal . . . . .	1
-53	QSWL1003.C	S048513	.... SWITCH, Door Open . . . . .	1
-54	VRDRV2EY.A	S048521	.... RESISTOR, 100 Ohms . . . . .	2
-55	XBBSD30P.D	4003910075	.... SCREW, Binder head, M3X8 . . . . .	2
-56	XBPNB30P.C	S048929	.... SCREW, Pan Head, M3X8 w/ washer assy . . . . .	2
-57	XBPNB40P.F	4009310080	.... SCREW, Pan Head, M4X6 . . . . .	1
-58	XBPSD20P.A	S048923	.... SCREW, Pan Head, M2X5 . . . . .	2
-59	XBPSD26P.B	S048933	.... SCREW, Pan Head, M2.5X8 . . . . .	1
-60	Not used			
-61	XWHSD200.A	S048891	.... WASHER, Door Open Sw PCB Bracket . . . . .	2
-62	XBPSD30P.i	S048939	.... SCREW, Pan Head, M3X8 . . . . .	2

## Safety/Slide Clamp Assembly 2 (Figure 8-14)

Item	Svc. Part #	Mfg. Part #	Description	Qty
8-14-	F049120020	F049120020	... PUMP 2, HEAD ASSY . . . . .	1
	CCRA1006.A	S047875	.... CLAMP, SAFETY SLIDE ASSEMBLY-P2 . . . . .	1
-1	LCHSM100.A	S048428	.... HOUSING, Upper-P2 . . . . .	1
-2	LCHSM100.B	S048429	.... HOUSING, Lower-P2 . . . . .	1
-3	LCHSM100.C	S048438	.... HOUSING, Slide Clamp, Sensor 1-P2 . . . . .	1
-4	LCHSM100.D	S048439	.... HOUSING, Slide Clamp, Sensor2-P2 . . . . .	1
-5	LCRA1006.A	S048430	.... CLAMP, Safety-P2 . . . . .	1
-6	LPiNS101.B	S048448	.... PIN, Release . . . . .	1
-7	LPiNS101.F	S048986	.... PIN, Dowel, Slide A . . . . .	1
-8	LPLTP107.A	S048434	.... PLATE, Motor Holding-P2 . . . . .	1
-9	LXRZ1002.A	S048881	.... E-RING, Shaft . . . . .	3
-10	MARMP100.A	S048023	.... ARM, Right Retainer-P2 . . . . .	1
-11	MARMP100.B	S048970	.... ARM, Left Retainer-P2 . . . . .	1
-12	MARMP100.C	S048437	.... ARM, Release-P2 . . . . .	1
-13	MCAMP100.B	S048435	.... LATCH, Safety-P2 . . . . .	1
-14	MSLiZ100.A	S048425	.... SLIDE A . . . . .	1
-15	MSLiZ100.B	S048424	.... LATCH, Slide-P2 . . . . .	1
-16	MSPRC101.D	S048500	.... SPRING, Slide Latch . . . . .	1
-17	MSPRD102.B	S048470	.... SPRING, Retainer Arms . . . . .	2
-18	MSPRD102.C	S048472	.... SPRING, Slide Shaft . . . . .	1
-19	MSPRD102.D	S048469	.... SPRING, Safety Clamp . . . . .	1
-20	MSPRP102.A	S048642	.... SPRING, Flat, Slide Shaft . . . . .	1
-21	NSFTD103.B	S048449	.... SHAFT, Slide . . . . .	1
-22	LPiND101.D	S048450	.... PIN, Release . . . . .	1
-23	NSFTD103.C	S048451	.... SHAFT, Safety Latch . . . . .	1
-24	NSFTD103.D	S048452	.... SHAFT, Safety Clamp . . . . .	1
-25	PSLDP100.B	S048456	.... SEAL, Safety Clamp-P2 . . . . .	1
-26	PZETL101.B	S048464	.... FILM, Insulation, PCB . . . . .	1
-27	PZETL101.C	S048463	.... FILM, FPC Insulation-P2 . . . . .	1
-28	CPWBN105.C	S050046	.... PCB, Slide Clamp, Sensor 2-P2 . . . . .	1
-29	QPWBN105.C	S048461	.... FLXBL PC, Slide Clamp, Sensor 1-P2 . . . . .	1
-30	XBPSD30P.i	S048939	.... SCREW, Pan Head, M3X8 w/ washer assy . . . . .	2

**Safety/Slide Clamp Assembly 2 (Figure 8-14) continued**

---

<b>Item</b>	<b>Svc. Part #</b>	<b>Mfg. Part #</b>	<b>Description</b>	<b>Qty</b>
-31	XBSSD30P.B	XBSSD30P10000	..... SCREW, Upper housing . . . . .	2
-32	XBSUF20P.C	XBSUF20P06000	..... SCREW, SCS1 Sensor housing . . . . .	1
-33	XJPSD30P.A	XJPSD30P06000	..... SCREW, Flat spring . . . . .	1
-34	XJPSF20P.B	XJPSF20P04000	..... SCREW, FPC . . . . .	2
-35	XJPSF20P.A	XJPSF20P06000	..... SCREW, SCS2 Sensor housing . . . . .	2

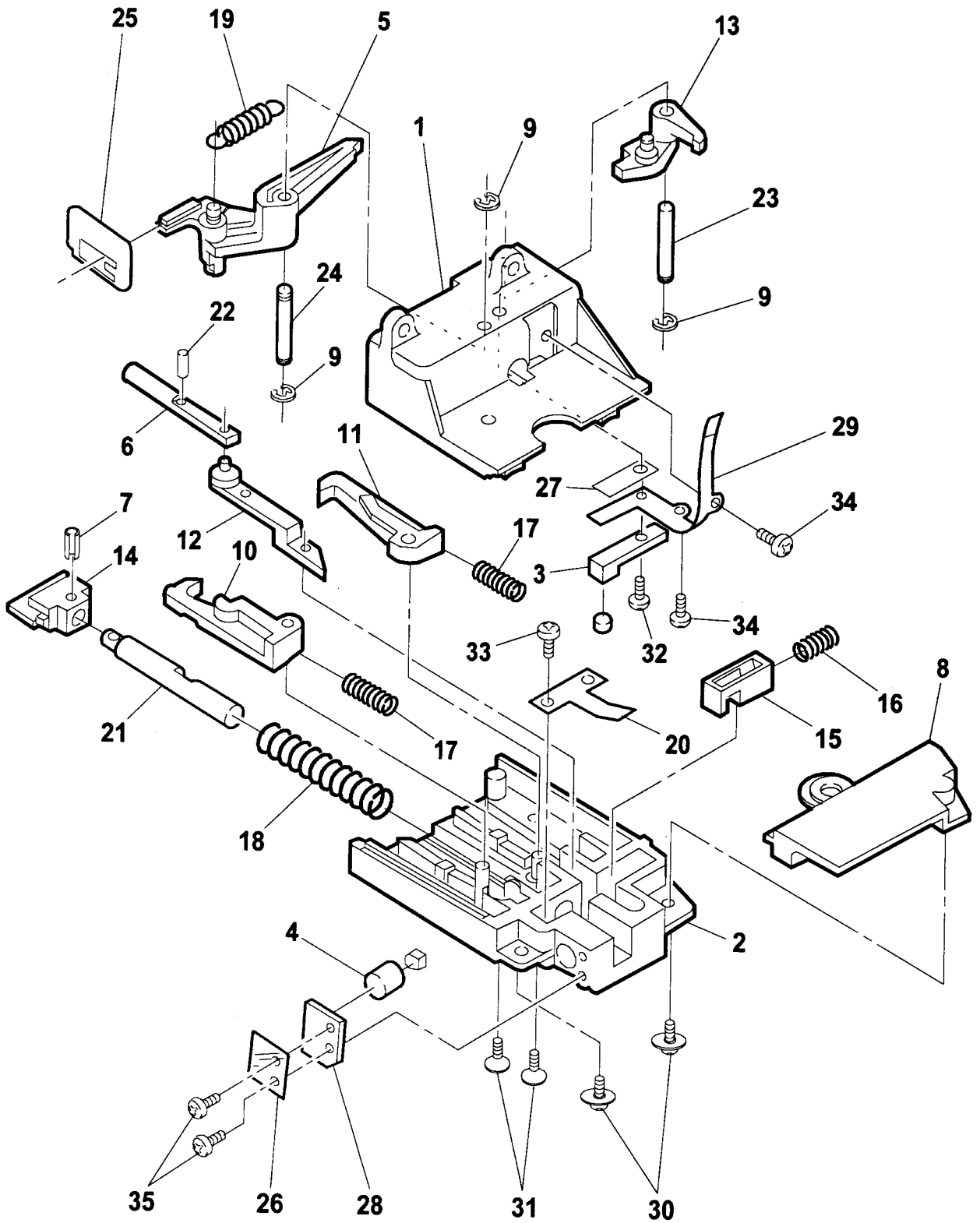
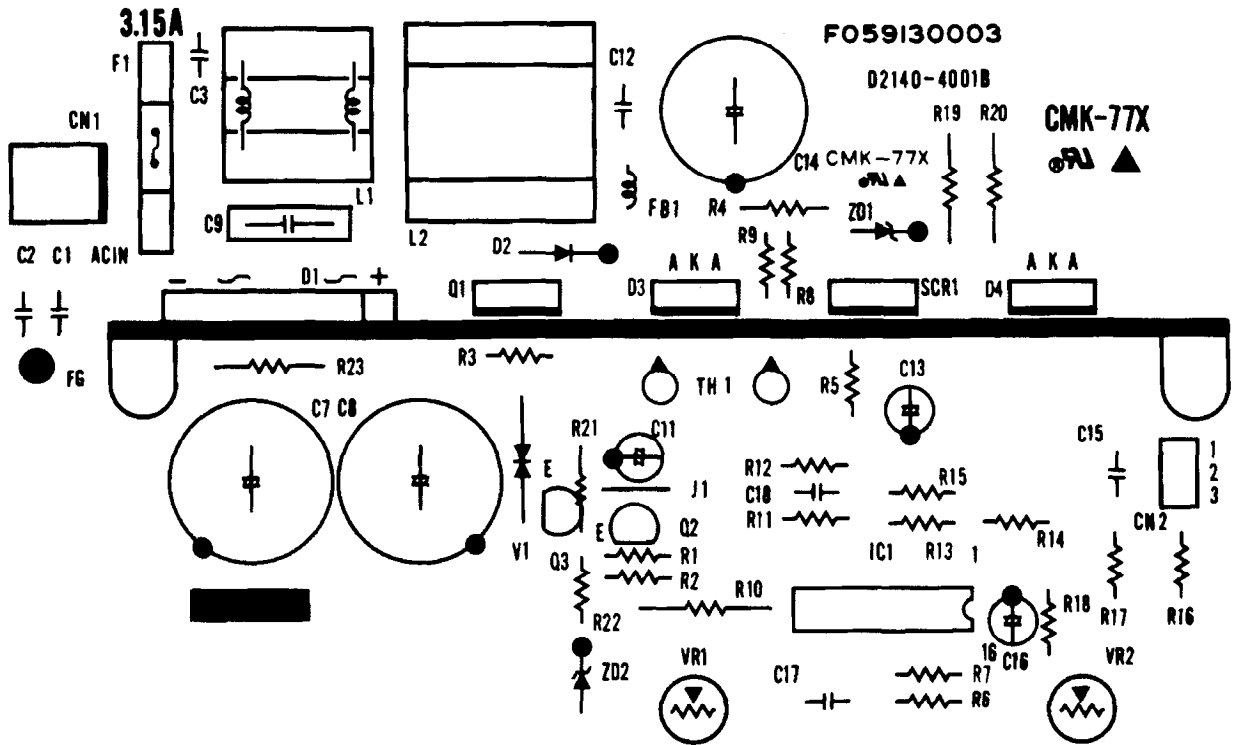

Figure 8-14. Safety/Slide Clamp Assembly 2

**Power Supply Board (Figure 8-15)**

---

Item	Svc. Part #	Mfg. Part #	Description	Qty
	RDENC100.E	F059130003	... PCB ASSEMBLY-POWER SUPPLY . . . . .	1
-1	0CBPJCJS.B	5009425013	.... FUSE (F1) . . . . .	1
-2	0CBPZZ06.A	5009420005	.... HOLDER, FUSE (FH1) . . . . .	1
-3	0CBPKZ05.A	5009410040	.... CONNECTR, 2 Pin . . . . .	1



Power Supply Board - Component Side

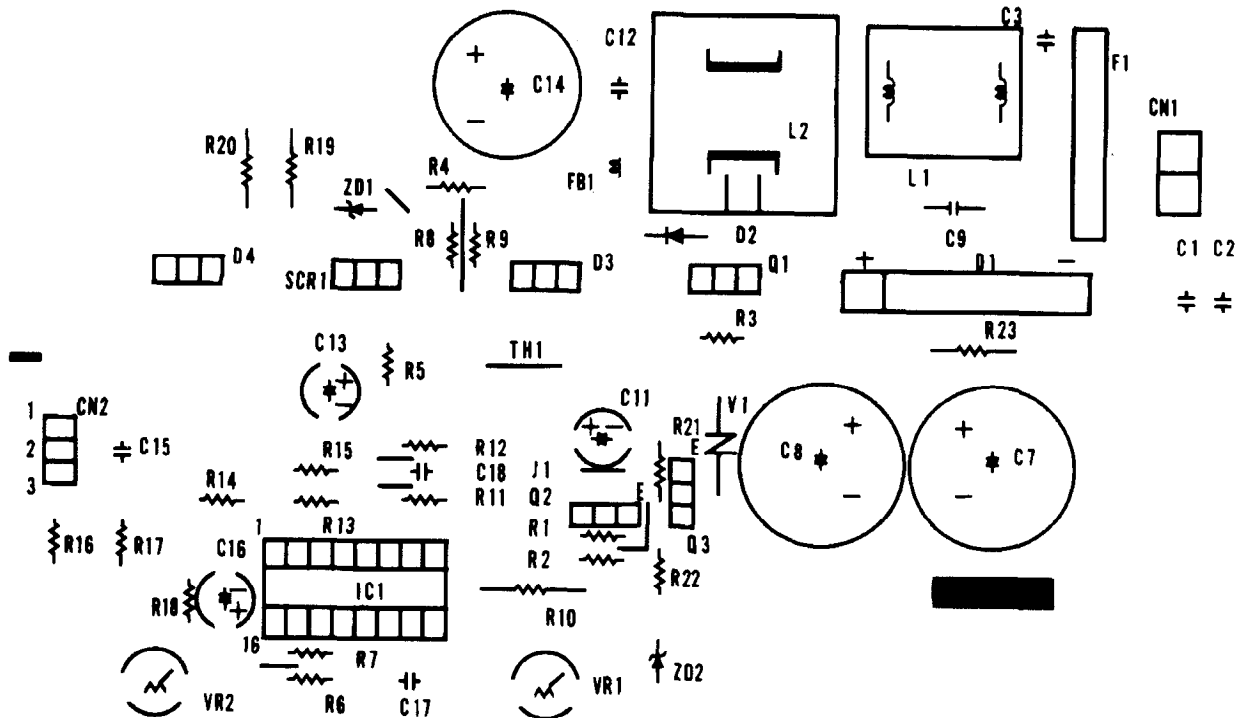

Figure 8-15. Power Supply Board - Solder Side

**Display PCB (Figure 8-16)**

Item	Svc. Part #	Mfg. Part #	Description	Qty
	CPWBN105.D	F052130001	... PCB, ASSEMBLY-Display . . . . .	1
-1	PGUMS101.A	5009440001	.... STRIP, Zebra . . . . .	4
-2	PSEL1008.A	3004090005	.... SEAL, DUST, LCDs . . . . .	1
-3	PZETL100.A	F044610001	.... COVER, LCD Insulation . . . . .	2
-4	QCNCM104.D	5009410012	.... CONNECTR, 3 Pin (CN304) . . . . .	1
-5	QCNCW104.E	5009410037	.... CONNECTR, 40 Pin (CN901) . . . . .	1
-6	RUNT1003.A	5009492007	.... BACKLIGHT, Message LCD . . . . .	2
-7	RUNT1004.A	5009492008	.... BACKLIGHT, Programming LCD . . . . .	2
-8	UBATL100.A	5009480002	.... BATTERY, Lithium . . . . .	1
-9	XUPSD26P.A	4009310019	.... SCREW, Pan Hd-Tapping, M2.6X8 . . . . .	14
-10	XUPSD26P.C	4009310076	.... SCREW, Pan Hd-Tapping, M2.6X10 . . . . .	2



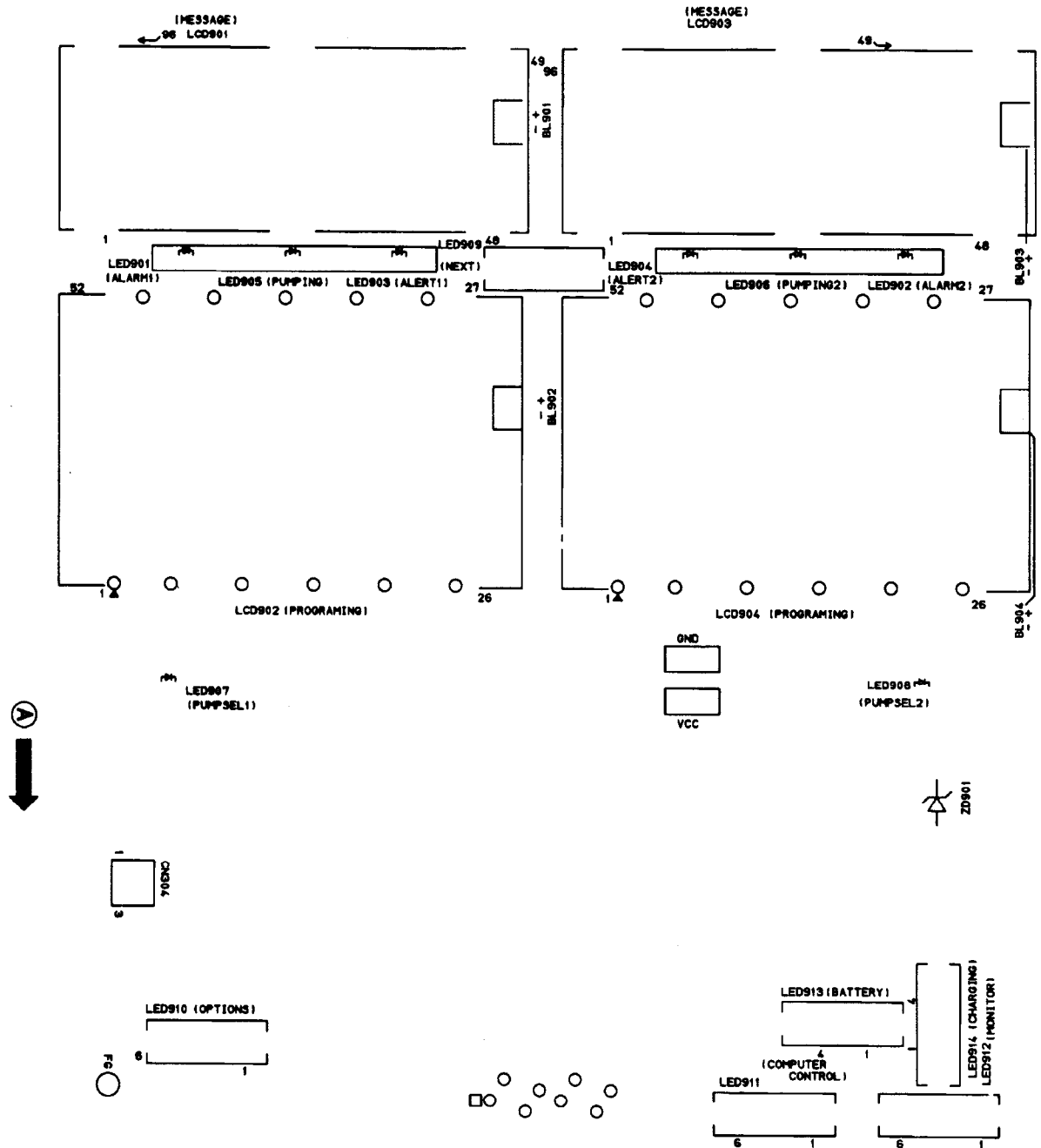

Figure 8-16 (Sheet 1 of 2). Display PCB-Component Side

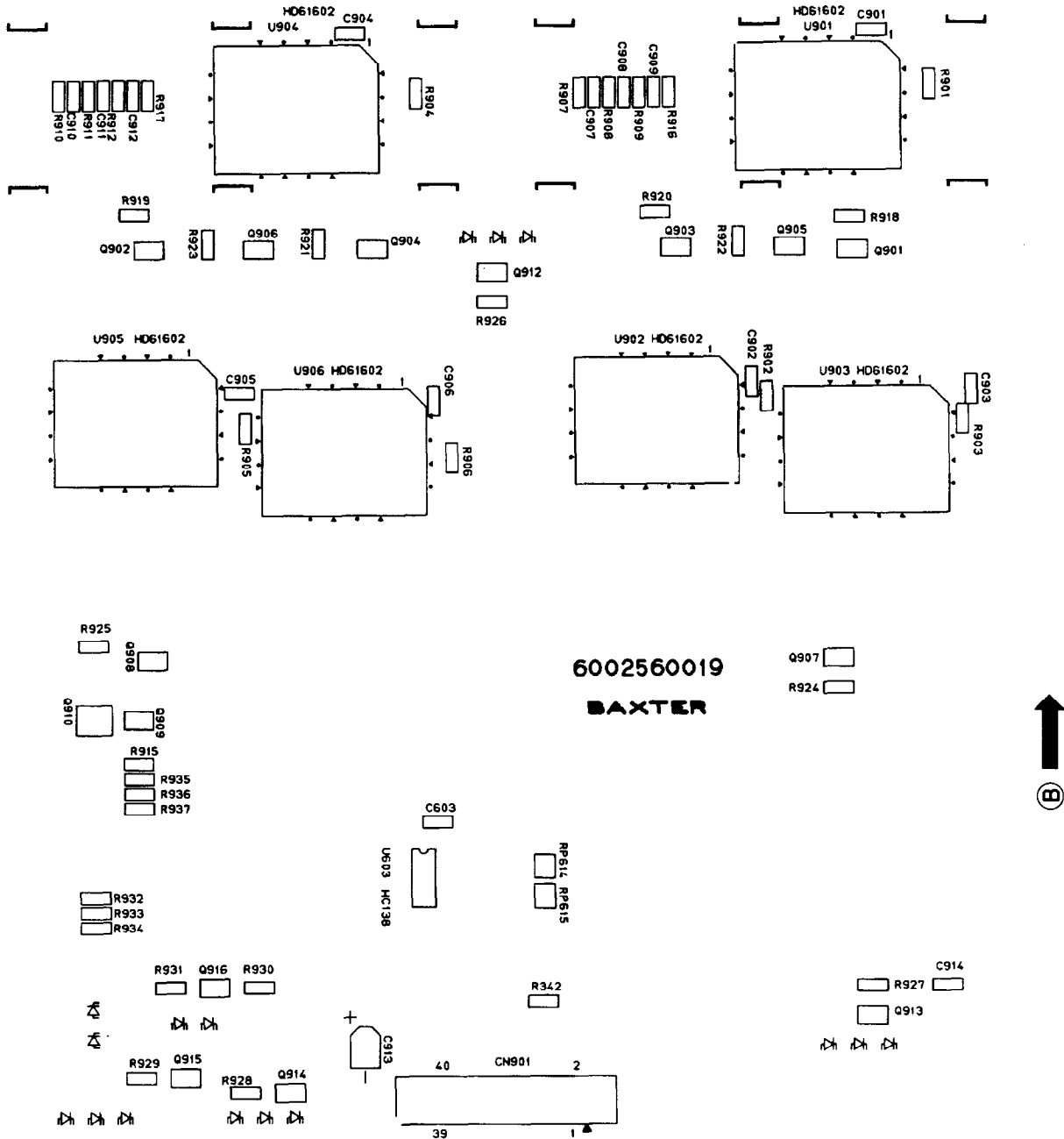

Figure 8-16 (Sheet 2 of 2). Display PCB - Solder Side

**CPU PCB (Figure 8-17)**

Item	Svc. Part #	Mfg. Part	Description	Qty
	CPWBX105.A	F051130002	... PCB, ASSEMBLY-CPU . . . . .	1
-1	QCNCM012.A	5009410003	.... CONNECTR, Test Point, GND . . . . .	1
-2	QCNCM100.A	5009410004	.... CONNECTR, 2 Pin (CN302) . . . . .	1
-3	QCNCM100.B	5009410005	.... CONNECTR, 3 Pin (CN301) . . . . .	1
-4	QCNCM100.D	5009410007	.... CONNECTR, 6 Pin (CN851, CN852) . . . . .	2
-5	QCNCM101.A	5009410029	.... CONNECTR, 5 Pin (CNTEST2) . . . . .	1
-6	QCNCM104.B	5009410010	.... CONNECTR, 40 Pin (CNDISP) . . . . .	1
-7	QCNCM104.C	5009410011	.... CONNECTR, 11 Pin (CN201, CN202) . . . . .	2
-8	QCNCM233.B	5009410015	.... CONNECTR, 8 Pin (CN811, CN812, CNTEST1) . . . . .	3
-9	QCNCM233.C	5009410016	.... CONNECTR, 9 Pin (CN803, CN804) . . . . .	2
-10	QCNCM701.A	5009410034	.... CONNECTR, 10 Pin . . . . .	1
-11	QCNCW100.A	5009410031	.... CONNECTR, 8 Pin (CN 601, CN602) . . . . .	2
-12	QCNCW103.A	5009410036	.... CONNECTR, 2 Pin . . . . .	1
-13	QCNCW142.A	5009410021	.... CONNECTR, CNI/F . . . . .	1
-14	QFSH4330.A	5009425004	.... FUSE, 1.5 A, 125 V, SB (F201) . . . . .	2
-15	QFSH8300.A	5009425005	.... FUSE, 1 A, 125 V (F302) . . . . .	1
-16	VHViCPF1.A	6009590001	.... PROTECTR, IC, 600 mA ICP301 (F15) . . . . .	1

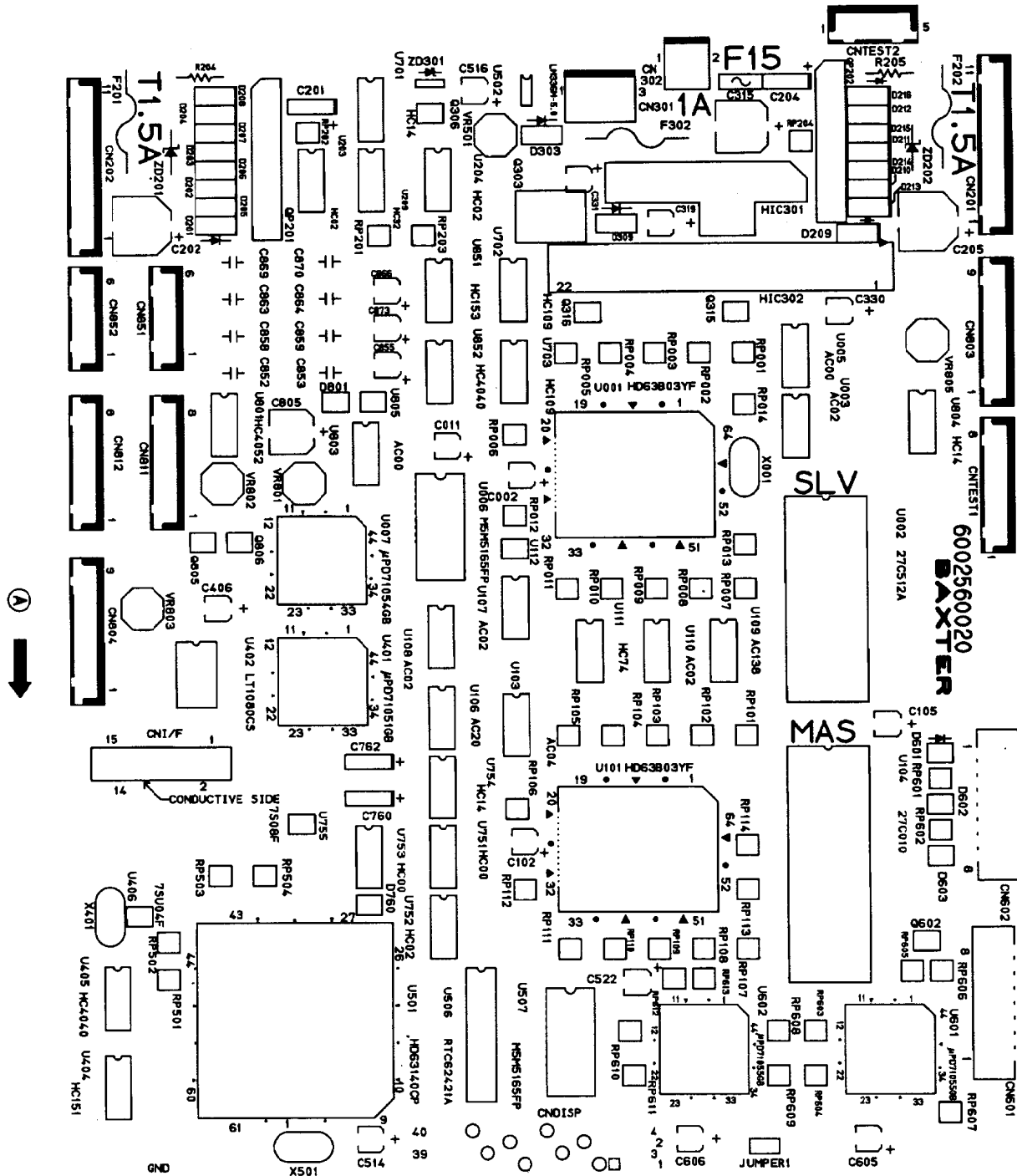

Figure 8-17 (Sheet 1 of 2). CPU PCB - Component Side

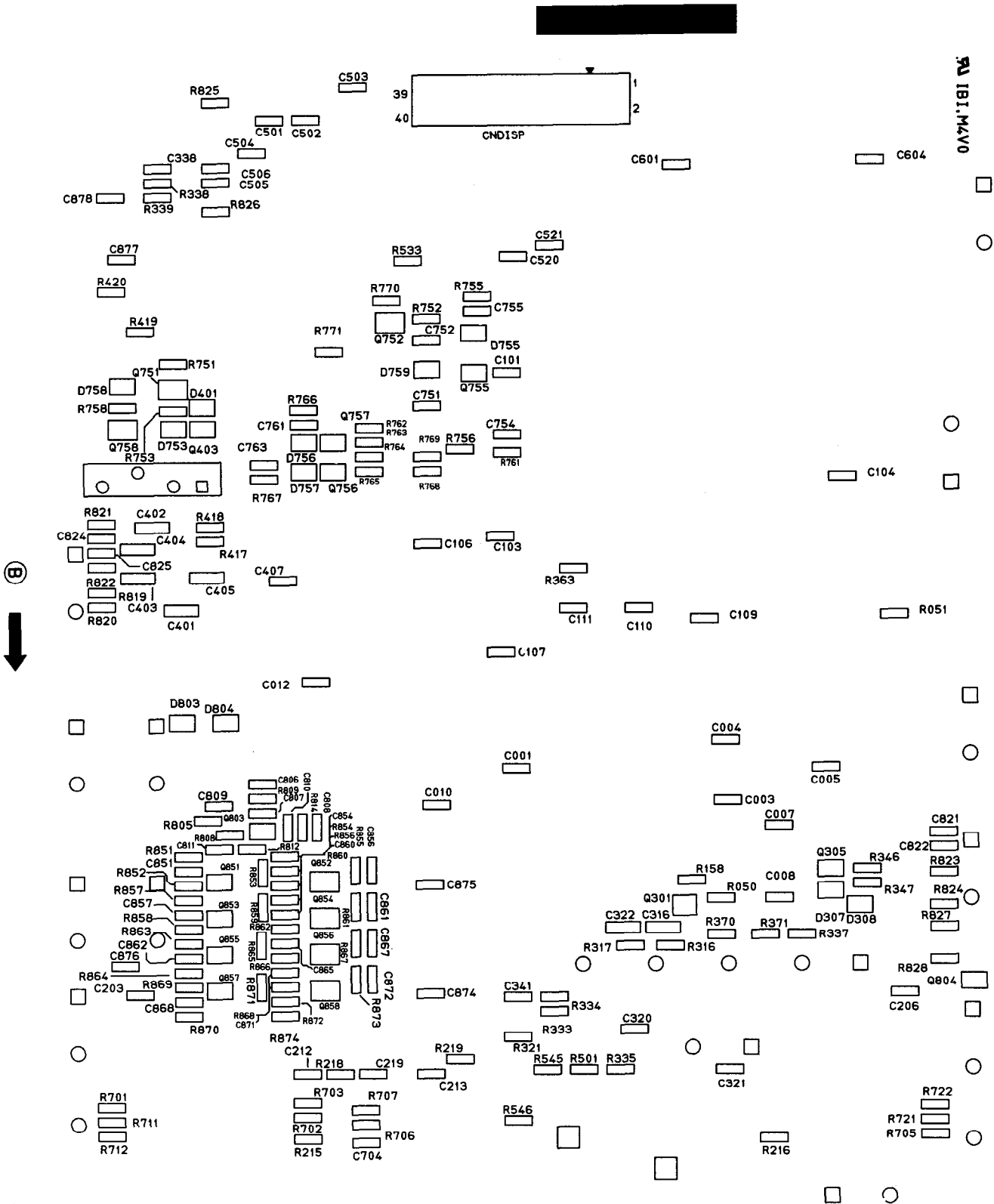

Figure 8-17 (Sheet 2 of 2). CPU PCB - Solder Side

**Terminal PCB (Figure 8-18)**

Item	Svc. Part #	Mfg. Part #	Description	Qty
	CPWBN104.B	F043130001	... PCB ASSEMBLY-Terminal . . . . .	1
-1	QCNCM233.A	5009410014	.... CONNECTR, 7 Pin (CN701) . . . . .	1
-2	QCNCM233.C	5009410016	.... CONNECTR, 9 Pin (CN401) . . . . .	1
-3	QCNCW142.A	5009410021	.... CONNECTR (CN-IF2) . . . . .	1
-4	RRLYD321.A	5009450001	.... RELAY (RY401) . . . . .	1

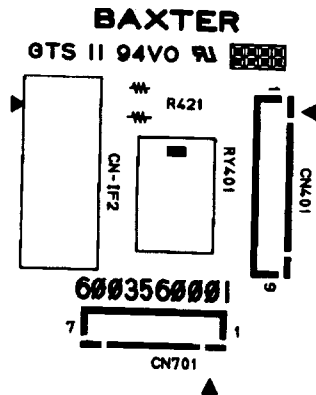
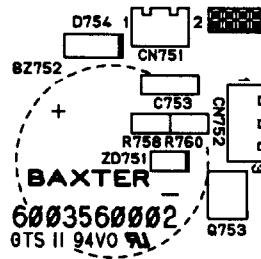

Figure 8-18. Terminal PCB

**Backup Buzzer Board (Figure 8-19)**

Item	Svc. Part #	Mfg. Part #	Description	Qty
	CPWBN104.D	F043130003	... PCB ASSEMBLY- Backup Aud Alrm . . . . .	1
-1	QCNCM100.C	5009410006	.... CONNECTR, 3 Pin (CN752) . . . . .	1
-2	QCNCM100.E	5009410008	.... CONNECTR, 2 Pin (CN751) . . . . .	1
-3	RALMB100.C	5009490001	.... BUZZER, Back Up (BZ752) . . . . .	1



*Figure 8-19. Backup Buzzer Board*

**Audible Alarm PCB (Figure 8-20)**

Item	Svc. Part #	Mfg. Part #	Description	Qty
	CPWBN105.A	F043130004	... PCB, ASSEMBLY-Audible Alarm . . . . .	1
-1	QCNCM105.A	5009410013	.... CONNECTR, 4 Pin (CN753) . . . . .	1
-2	RALMB100.A	5009490002	.... BUZZER, Main (BZ751) . . . . .	1

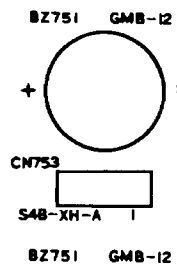

**Figure 8-20. Audible Alarm PCB**



**Parts list for Packaging Materials**

Item	Svc. Part #	Mfg. Part #	Description	Qty
	0705B1530	07-05-B1-530	. CARTON, Individual, Japan . . . . .	1
	0705C1719	07-05-C1-719	. CARTON, Individual, Singapore . . . . .	1
	SPAKA129.B	F052720001	. CUSHION, Right . . . . .	1
	SPAKA129.C	F052720002	. CUSHION, Left . . . . .	1
	SSAKH002.A	3004035007	. POUCH, Polyethylene . . . . .	1
	TiNSE111.B	07-19-B1-564	.. MANUAL, Operator's . . . . .	1
	TLABZ110.E	07-26-A1-202	.. LABEL, Slide Clmp Slot . . . . .	1
	SSAKA124.A	3004035002	.. POUCH, Polyethylene . . . . .	1
	TTAG1003.A	07-26-06-030	. TAG, Batt. Recharge . . . . .	1

**Parts list for Accessories and Options**

---

Item	Svc. Part #	Mfg. Part #	Description	Qty
	UKOG1013.B	F049230002	. GAUGE, Occl Sensor Cal . . . . .	1
	UKOG1020.A	3009090008	. XTRACTOR, UPP . . . . .	1
	UKOG1021.A	3009090007	. EXTRACTOR, Wire Harness . . . . .	1
	722003396	72-20-03-396	. SHIM, Air Sensor, Tubing guide . . . . .	1
	722003397	72-20-03-397	. ADHESIVE, Loctite* Prism 454 . . . . .	1
	3009035001	3009035001	. TIES, Wire . . . . .	1
	072601228	07-26-01-228	. LABEL, Batt. disposal . . . . .	1

\*Loctite, Inc.

## Section 9

---

# Warranty and Service Information

### 9.1 Warranty Information

Baxter Healthcare Corporation (“Baxter”) warrants that the equipment shall be free from defects in material and workmanship when delivered to the original purchaser. Baxter’s sole obligation shall be limited to repair or replacement, at Baxter’s option and expense, of the defective part or unit, excluding batteries, for a period of one year following the date of initial delivery. The warranty for batteries is limited to a period of six months following the date of initial delivery.

The warranty extends only to the original purchaser and is not assignable or transferable, and shall not apply to auxiliary equipment or disposable accessories.

THERE ARE NO OTHER WARRANTIES INCLUDING ANY IMPLIED WARRANTY AND ANY WARRANTY OF MERCHANTABILITY OR FITNESS FOR A PARTICULAR PURPOSE WHICH EXTEND BEYOND THE DESCRIPTION OF THE PRODUCT AND THOSE EXPRESSLY SET FORTH IN ITS LABELING. UNLESS USED ACCORDING TO THE DIRECTIONS ACCOMPANYING THE PRODUCT, ALL WARRANTIES ARE SPECIFICALLY EXCLUDED. In no event shall Baxter be responsible for incidental, consequential or exemplary damages. Modification, alteration, recalibration or abuse, and service by other than a Baxter authorized representative may void the warranty.

### 9.2 Service Information

While under Baxter Healthcare Corporation Warranty, Service Agreement (optional), or lease agreement, the instrument must not be opened by unauthorized personnel.

Call 1-(800) -THE-PUMP for service and repair information for all instruments.

Shipping costs for all units returned to Baxter shall be paid by the customer. The unit must be packed in its original container or in another Baxter approved container that will provide adequate protection during shipment. Before shipping any unit for repair, call 1-(800)-THE-PUMP and notify a Customer Service Representative to ensure prompt return of your device. When calling Product Service, please be prepared to provide code number and serial number of the unit. A brief written description of the problem should be attached to the instrument when it is returned for service.

Baxter Healthcare Corporation will not be responsible for unauthorized returns or for units damaged in shipment due to improper packing.

### **9.3 General Information**

For general information concerning this product, call Baxter Product Information at 1-800-933-0303. Baxter Healthcare Corporation reserves the right to change the design without notice.

# Section 10

---

## Diagrams

This section contains all of the schematic and wiring diagrams for the Flo-Gard® 6301 Dual Channel Volumetric Infusion Pump. These diagrams are intended only to assist the reader in understanding the theory of operation. The diagrams are listed below.

- Figure 10-1. System Block Diagram
- Figure 10-2. Rear Housing Wiring Diagram
- Figure 10-3. Front Housing Wiring Diagram
- Figure 10-4. CPU Board Block Diagram
- Figure 10-5. Power Supply Section
- Figure 10-6. DC Power Supply
- Figure 10-7. Power Supply Control
- Figure 10-8. Power Supply Control - Hybrid Circuit
- Figure 10-9. Master CPU Block Diagram
- Figure 10-10. Master CPU Schematic
- Figure 10-11. UPP, RTC and SRAM Block (P/O CPU Board)
- Figure 10-12. Alarm Control Circuit
- Figure 10-13. Address Decoder
- Figure 10-14. Serial Communication Block
- Figure 10-15. Slave CPU Block Diagram
- Figure 10-16. Slave CPU Schematic
- Figure 10-17. Slave RAM and Programmable Timer Module (PTM)
- Figure 10-18. Motor Driver Circuit - Pump 1
- Figure 10-19. Motor Driver Circuit - Pump 2
- Figure 10-20. CPU PCB (Sensor Block)
- Figure 10-21. PPI Block #1
- Figure 10-22. PPI Block #2
- Figure 10-23. Occlusion Sensing Block
- Figure 10-24. Air Sensing Block
- Figure 10-25. Misload and Slide Clamp Sensors

Figure 10-26. Display PCB

Figure 10-27. LCD Drivers for Pump 1

Figure 10-28. LCD Drivers for Pump 2

Figure 10-29. LCDs for Pump 1

Figure 10-30. LCDs for Pump 2

Figure 10-31. LED Lamps

Figure 10-32. Audible Alarm PCB

Figure 10-33. Backup Buzzer PCB

Figure 10-34. Terminal PCB

Figure 10-35. Accessories

Figure 10-36. Sensors on Pump head 1

Figure 10-37. Sensors on Pump head 2

Figure 10-38. Front Panel Key Assignments

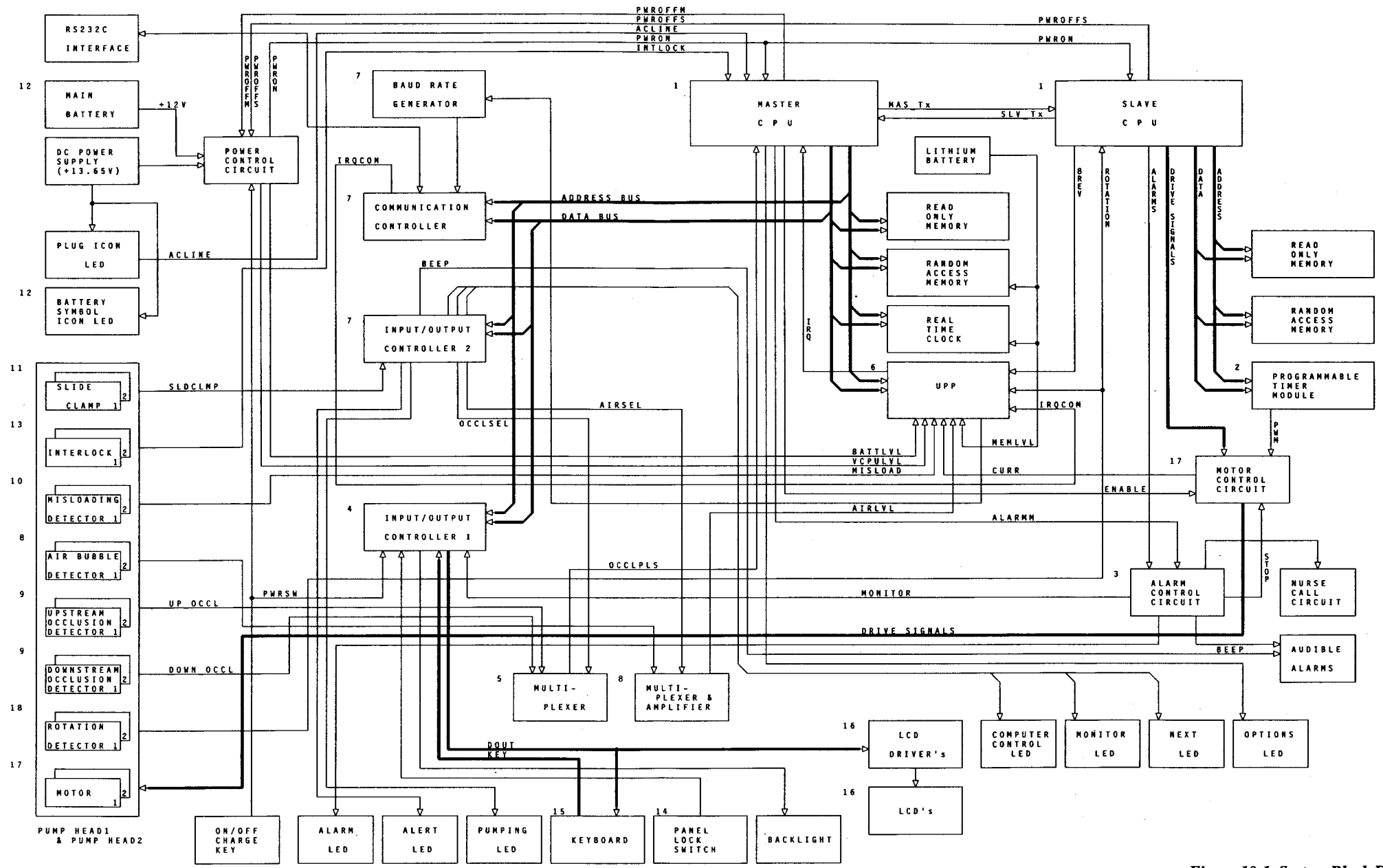

Figure 10-1. System Block Diagram

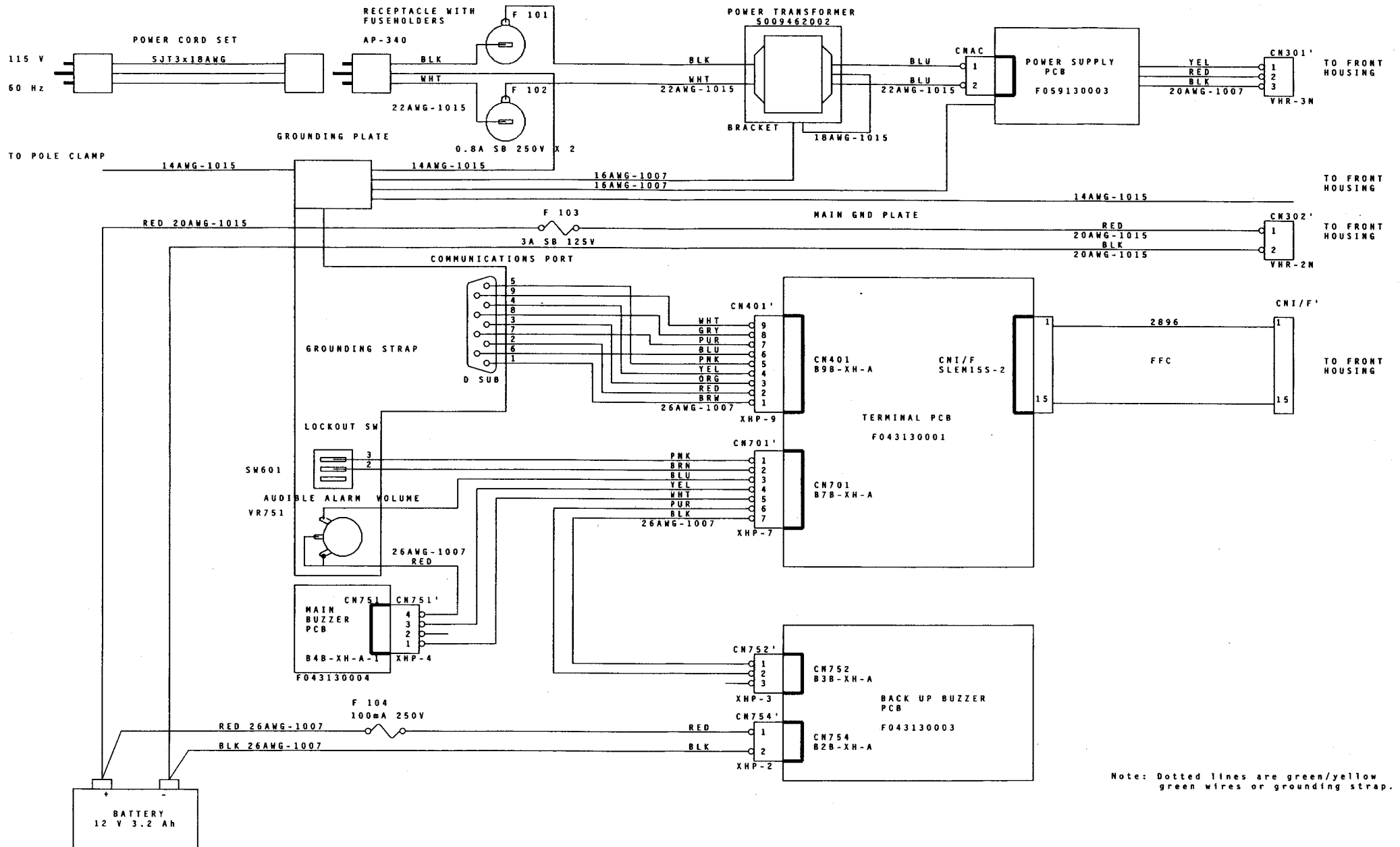
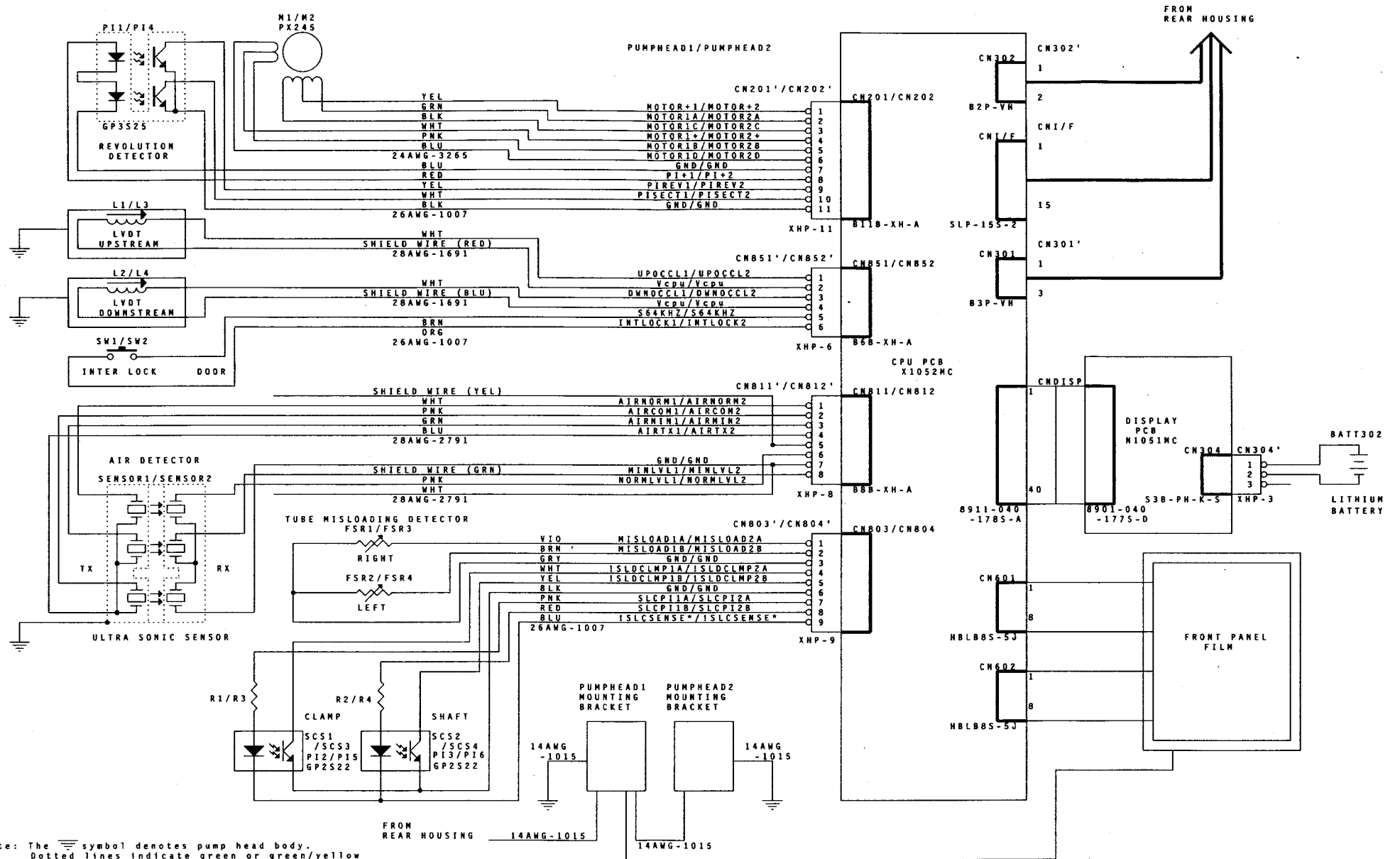

Figure 10-2. Rear Housing Wiring Diagram





Note: The symbol denotes pump head body. Dotted lines indicate green or green/yellow bonding wires and 18AWG-1007 if not specified.

Figure 10-3. Front Housing Wiring Diagram

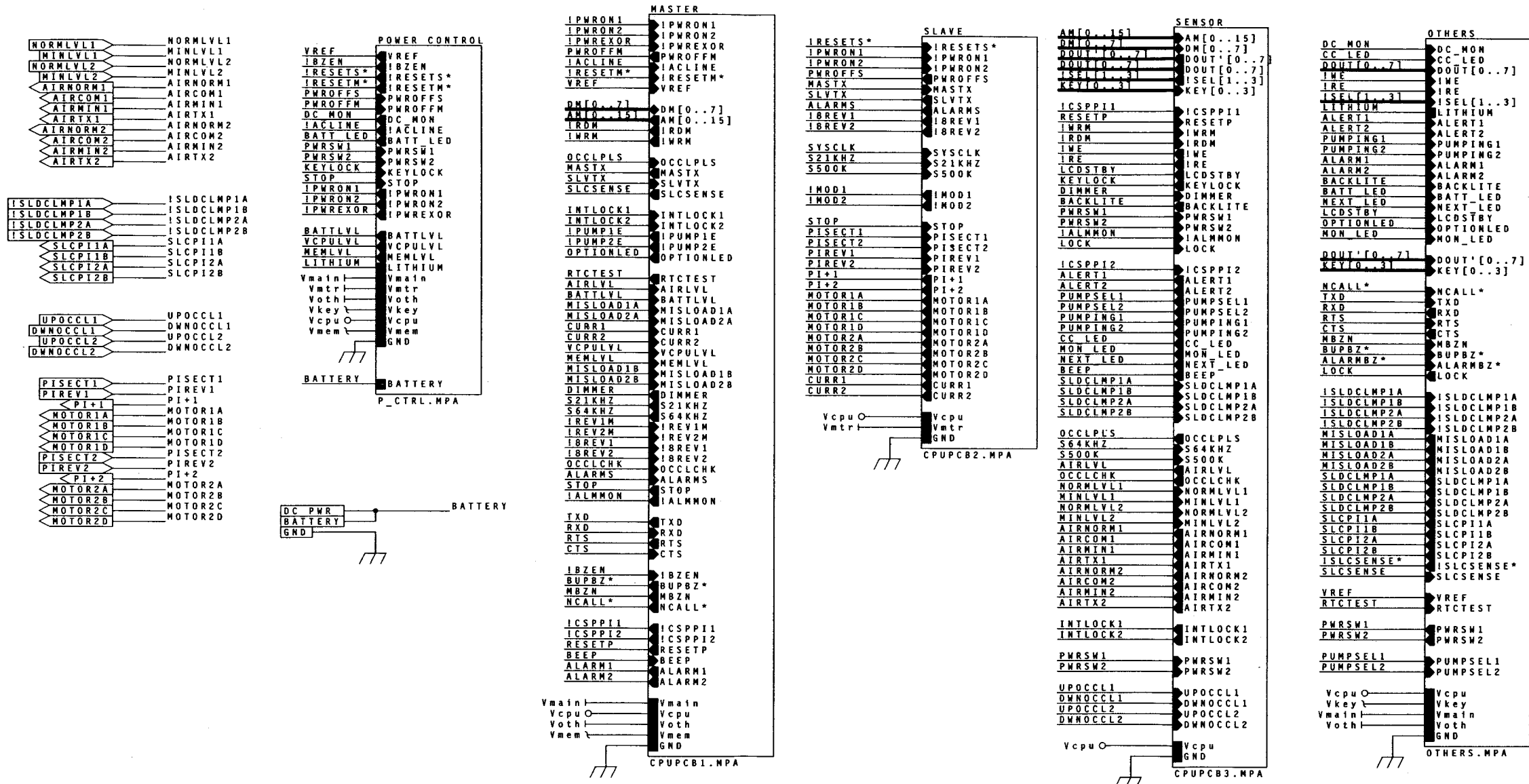
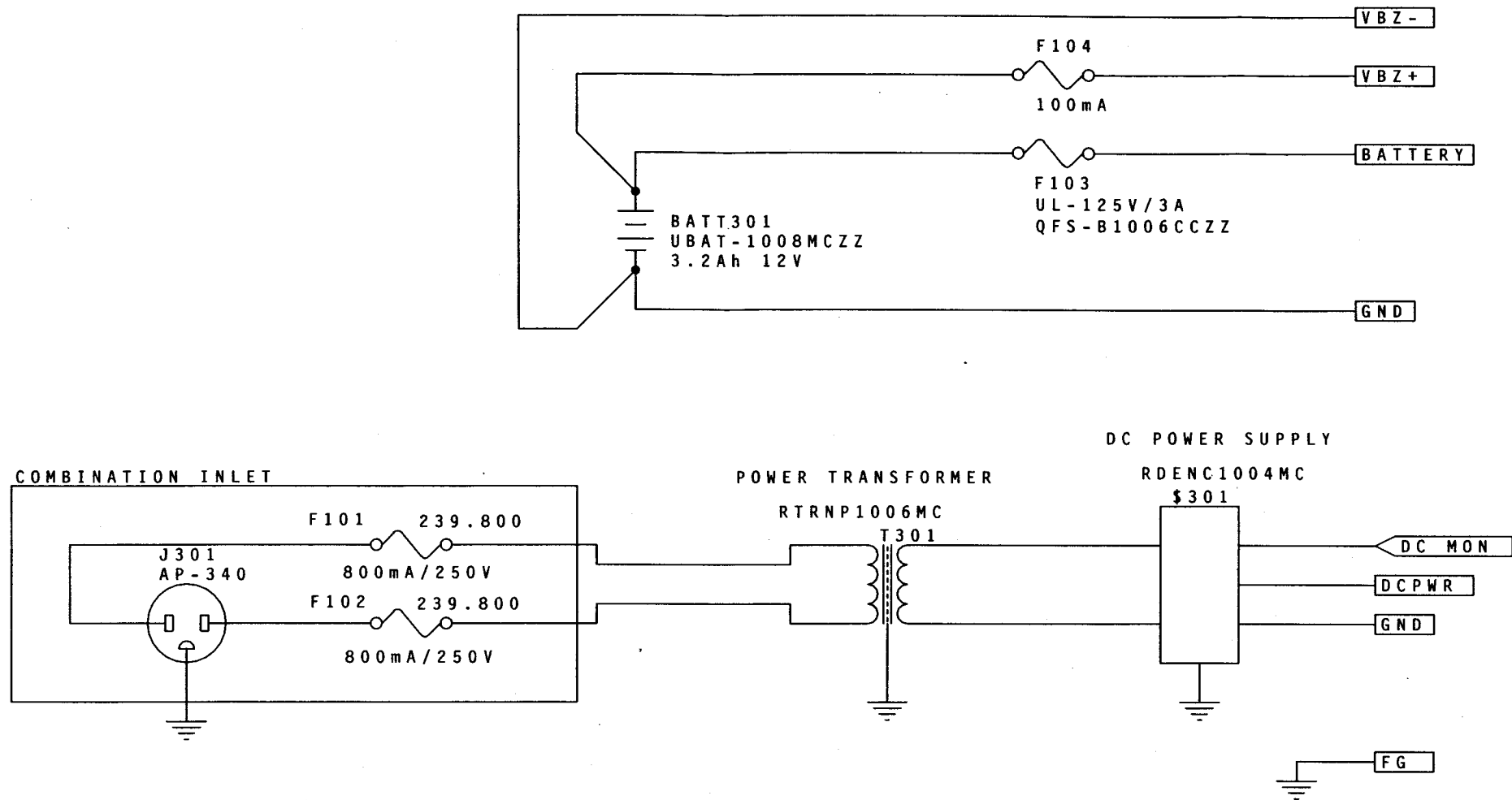

Figure 10-4. CPU Board Block Diagram



\$302  
 AC CORD  
 SET  
 QACCD7613QCN4

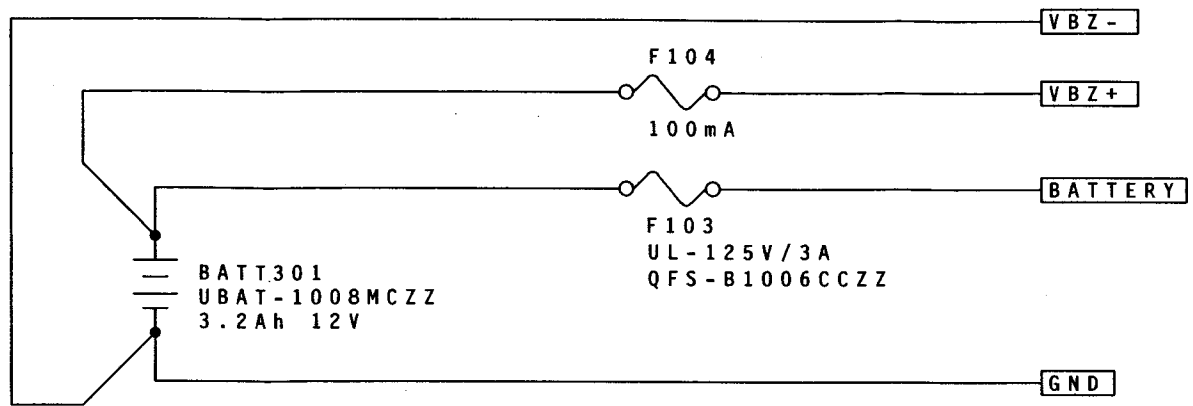

Figure 10-5. Power Supply Section

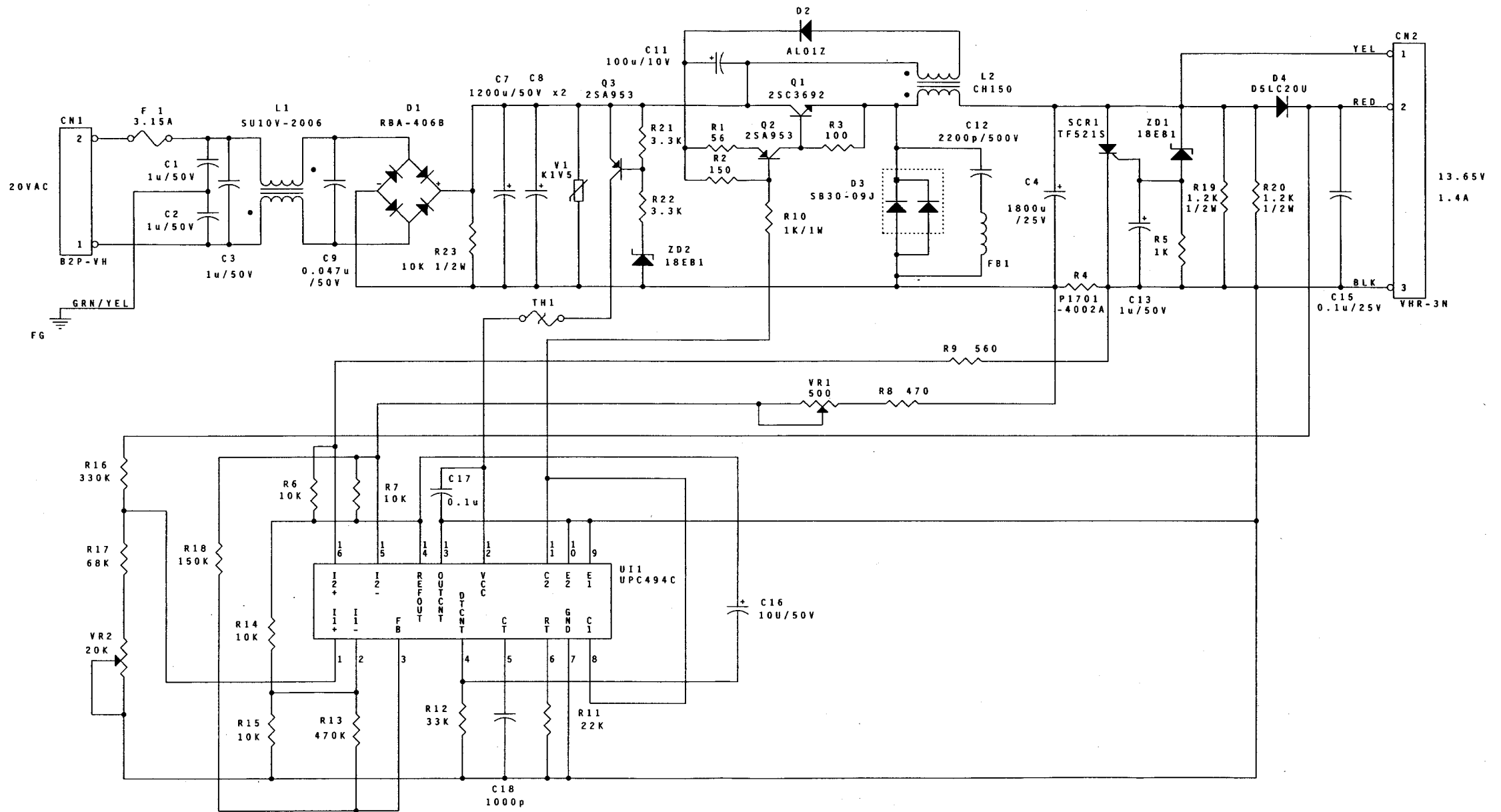

Figure 10-6. DC Power Supply

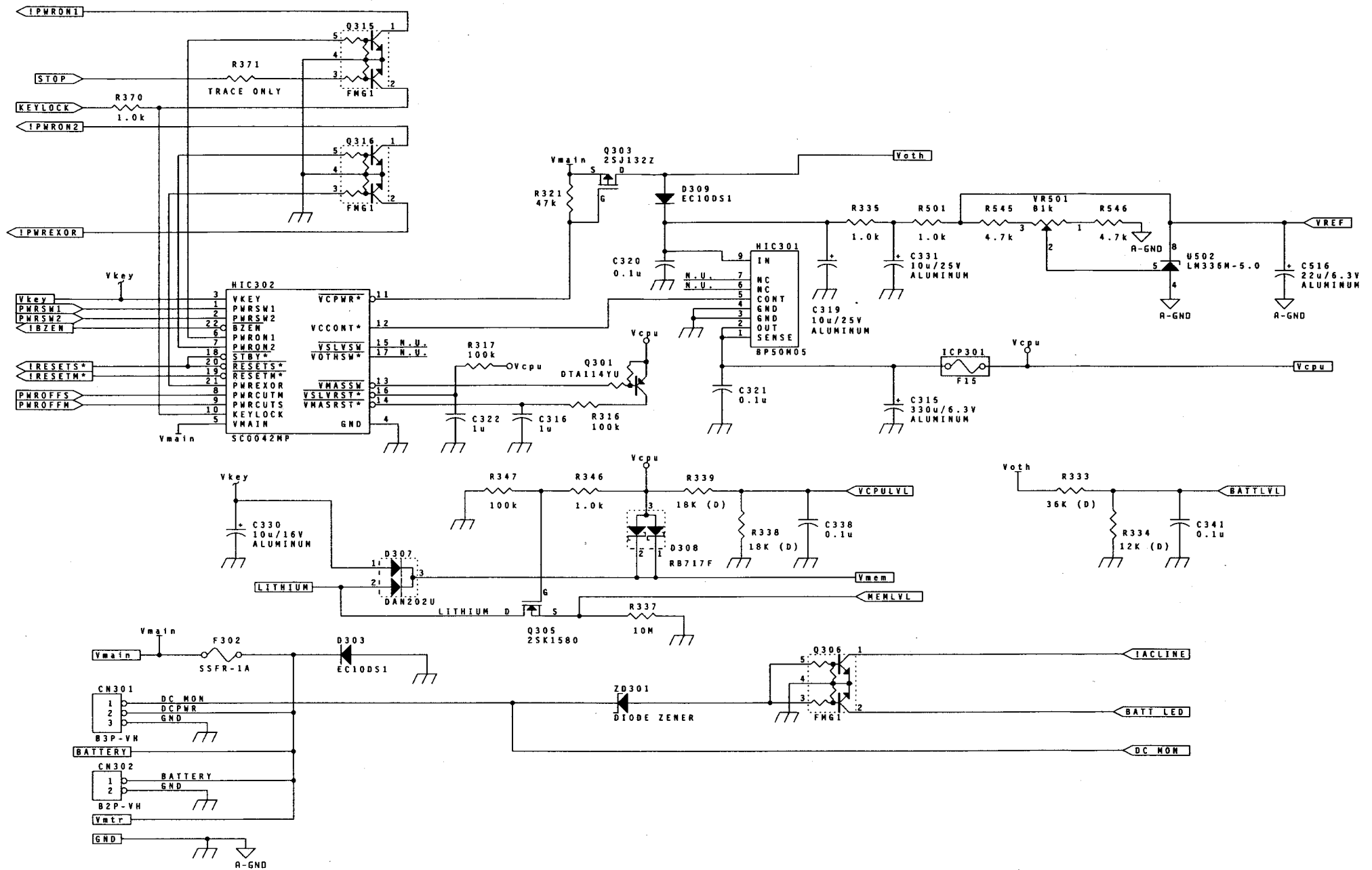

Figure 10-7. Power Supply Control - Hybrid Circuit

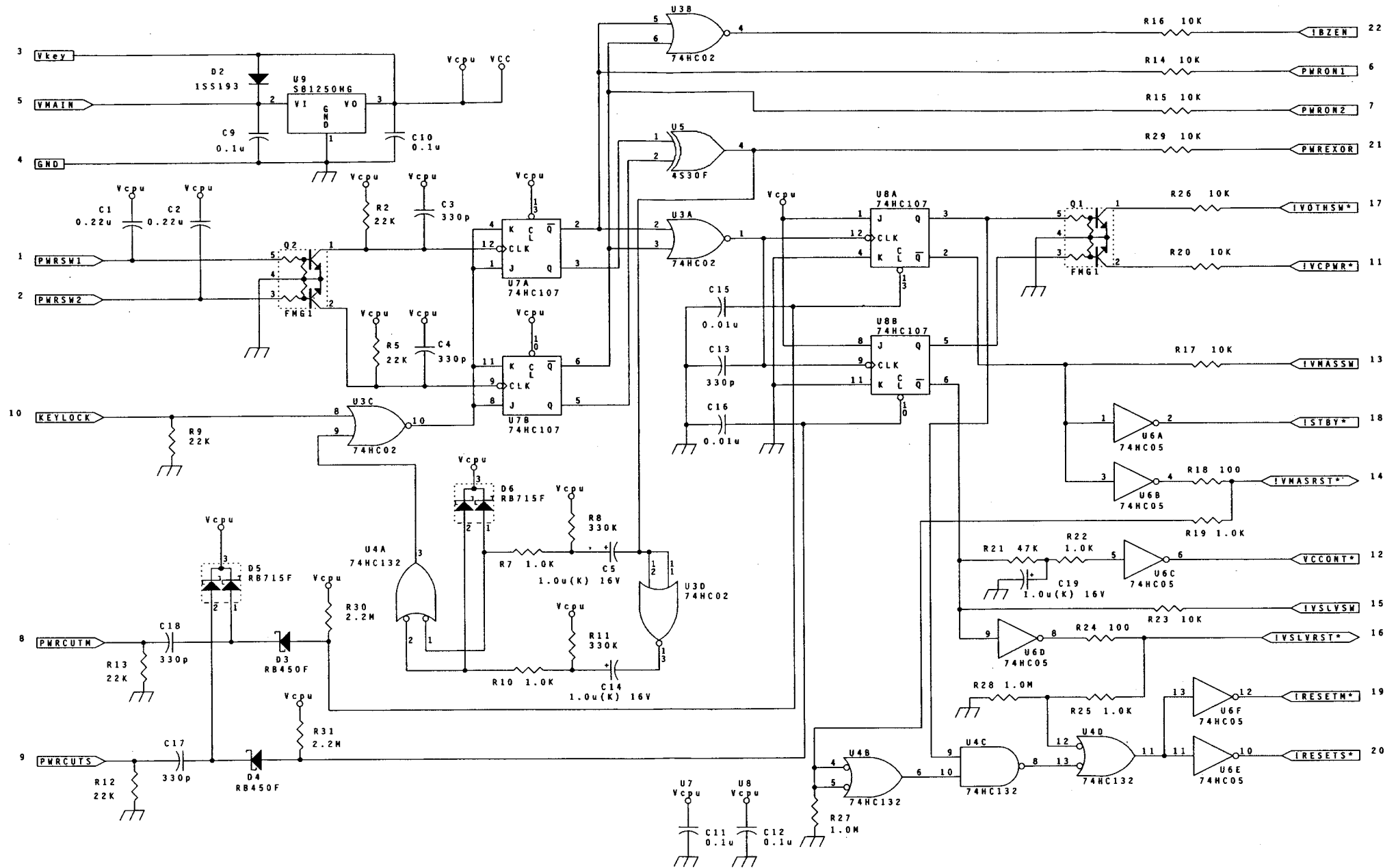

Figure 10-8. Power Supply Control - Hybrid Circuit

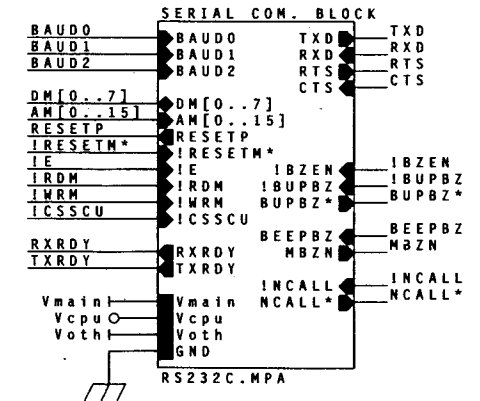
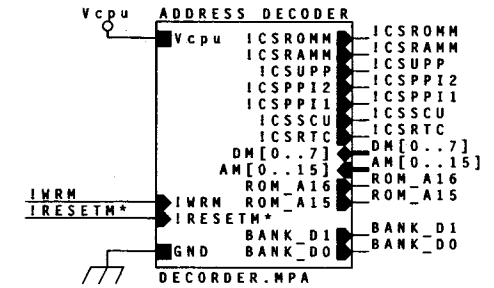
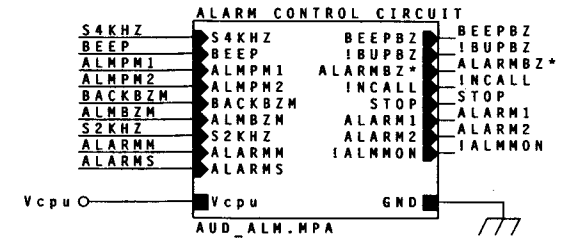
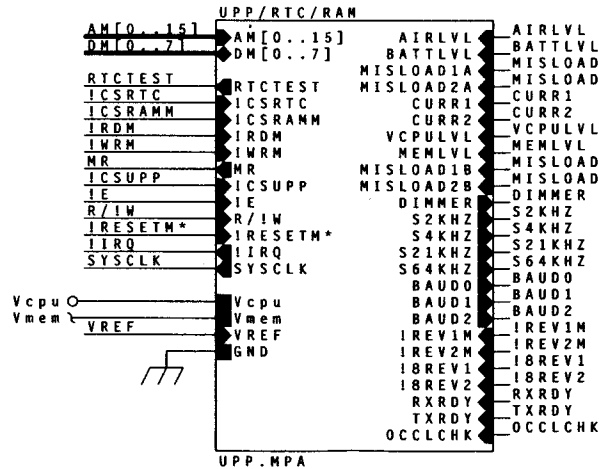
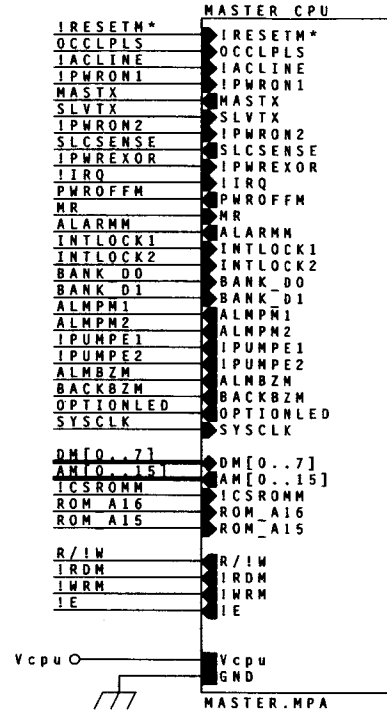
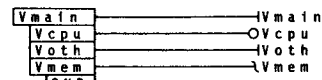
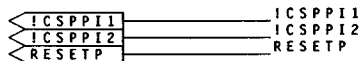
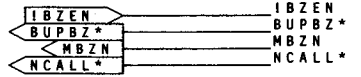
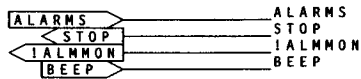
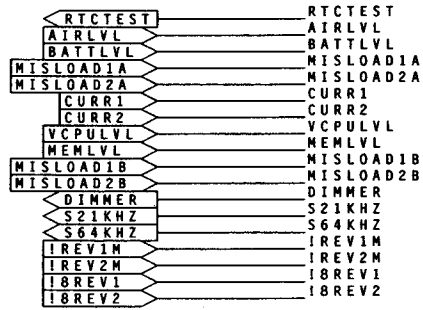
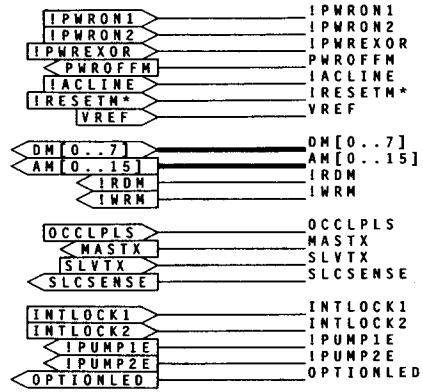

Figure 10-9. Master CPU Block Diagram

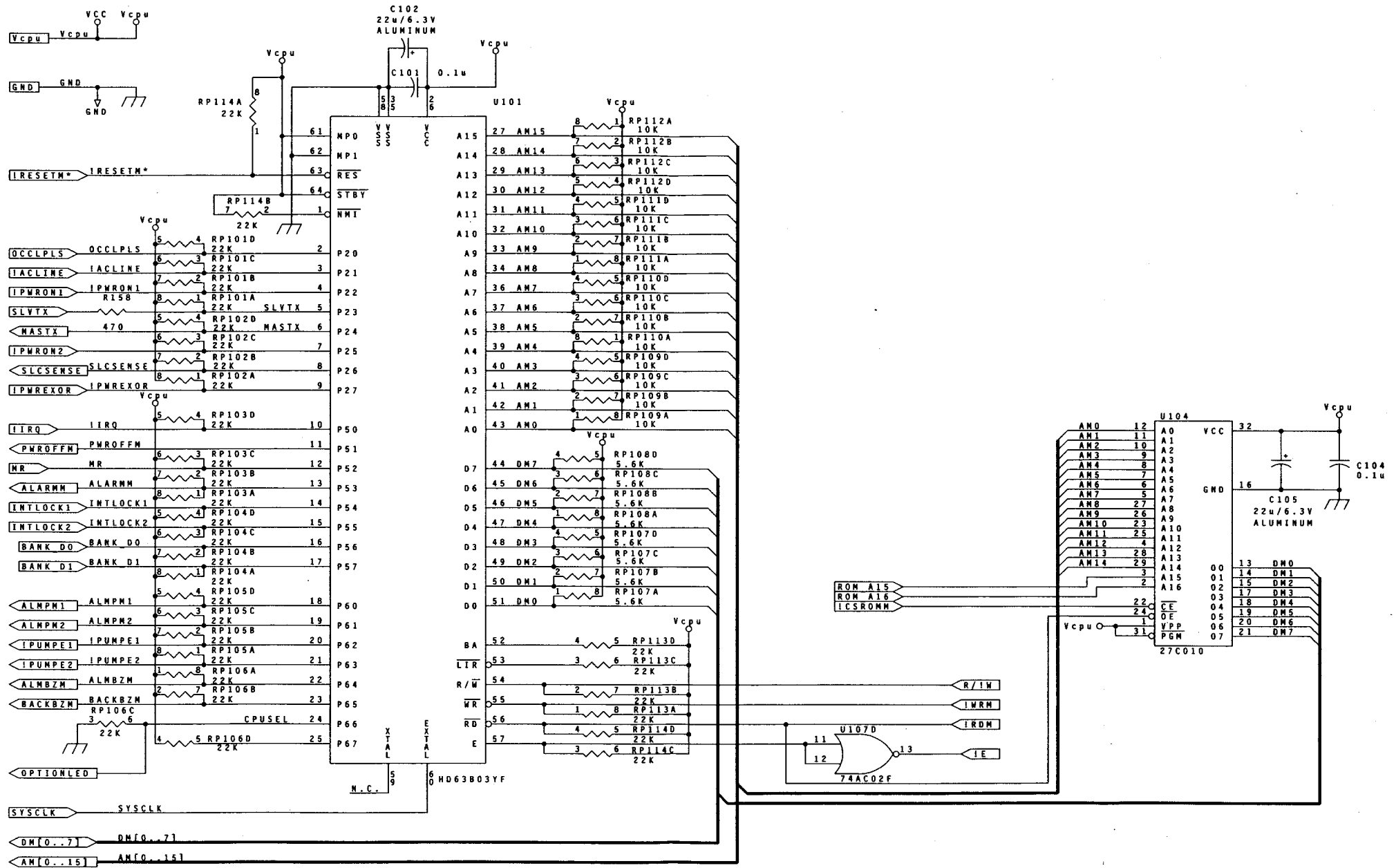
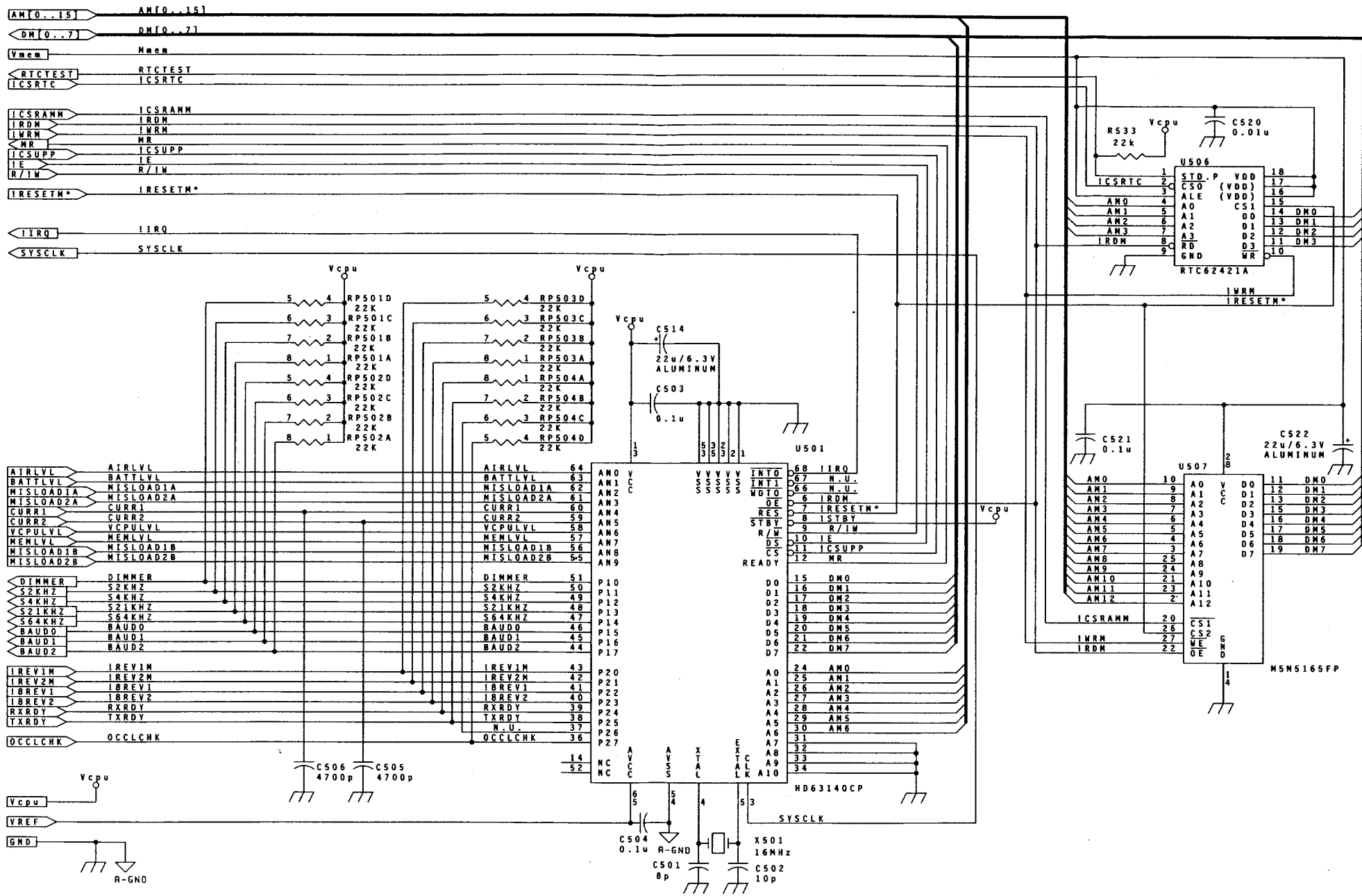

Figure 10-10. Master CPU Schematic





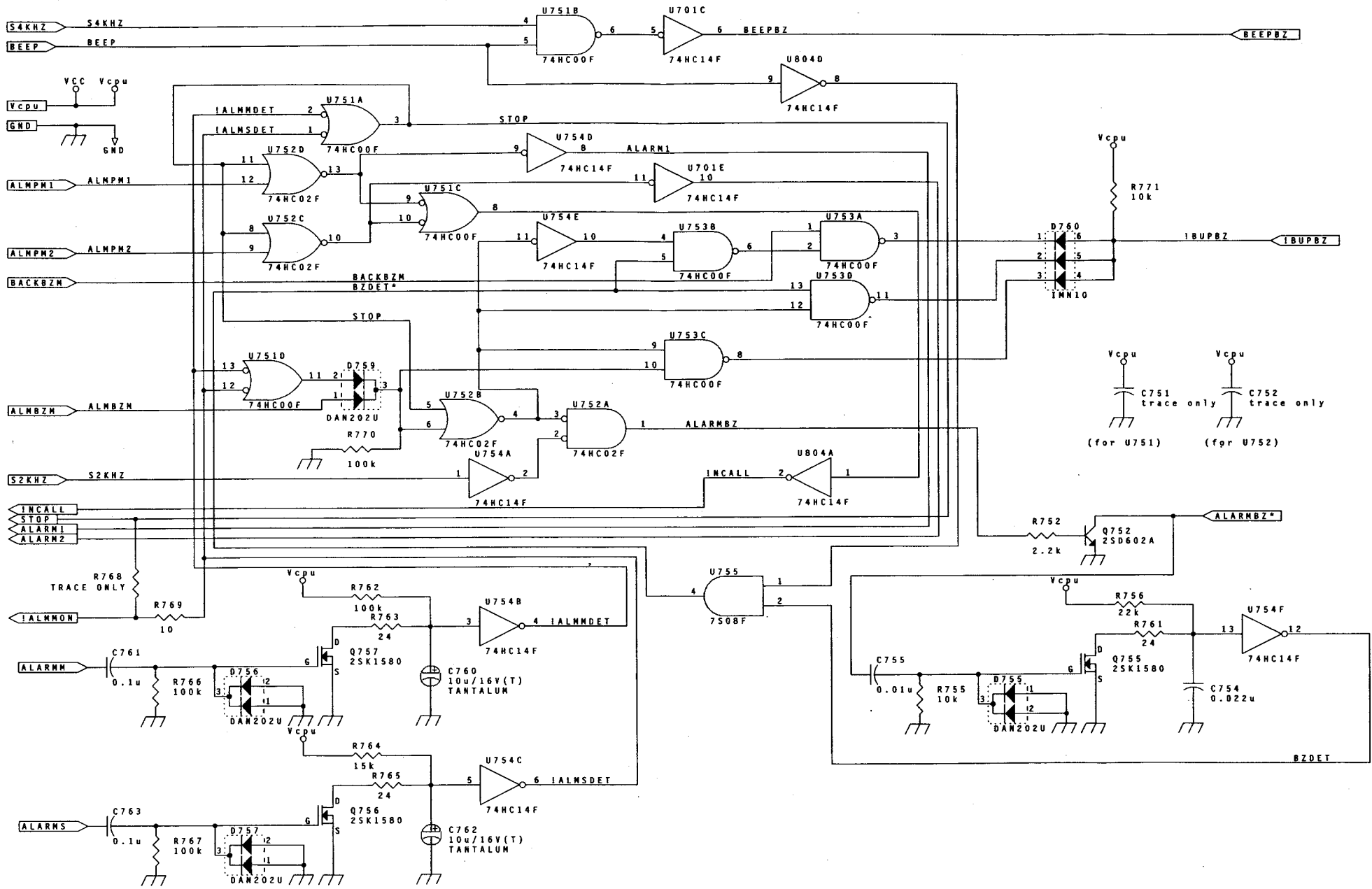

Figure 10-12. Alarm Control Circuit

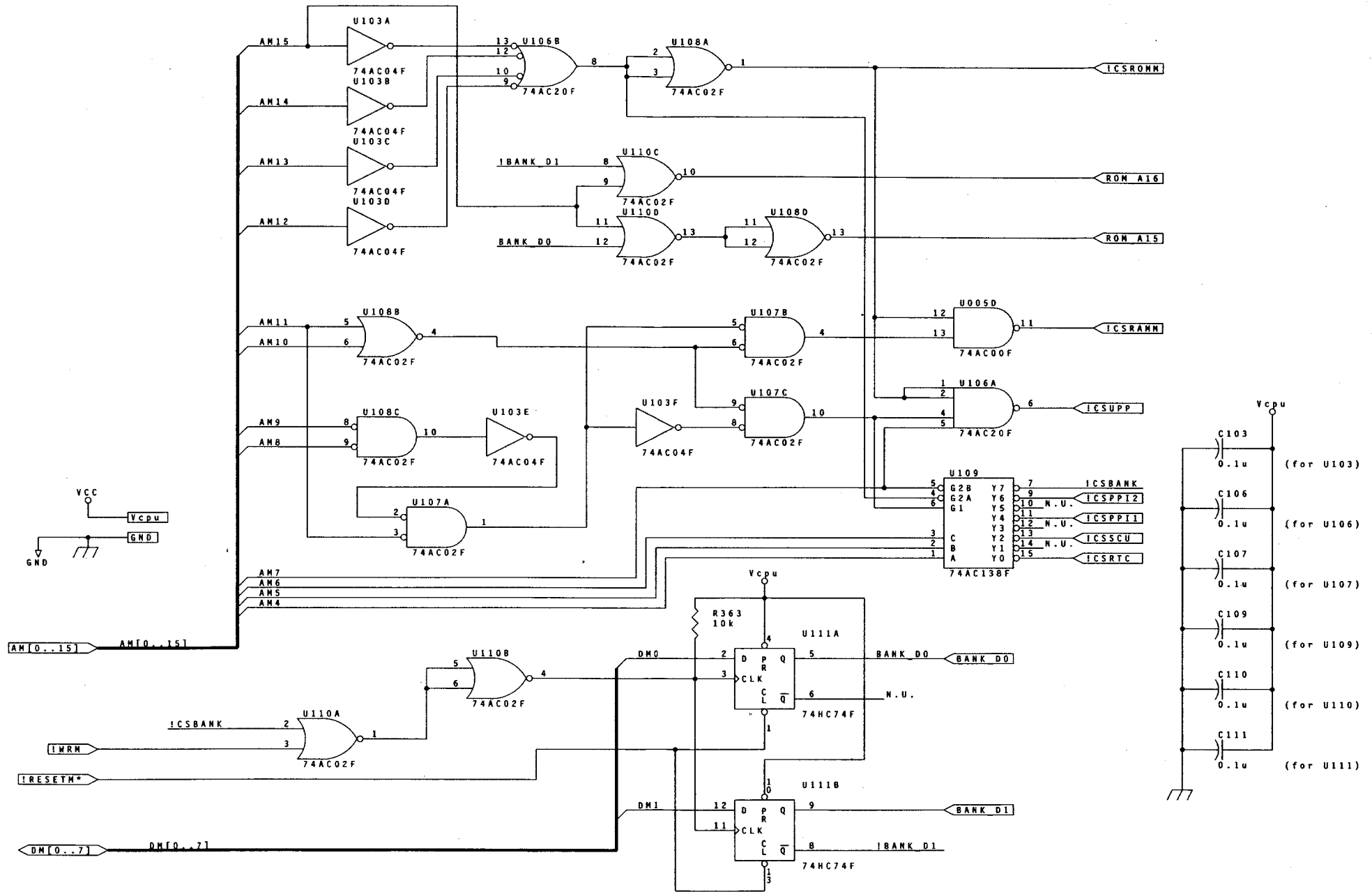

Figure 10-13. Address Decoder

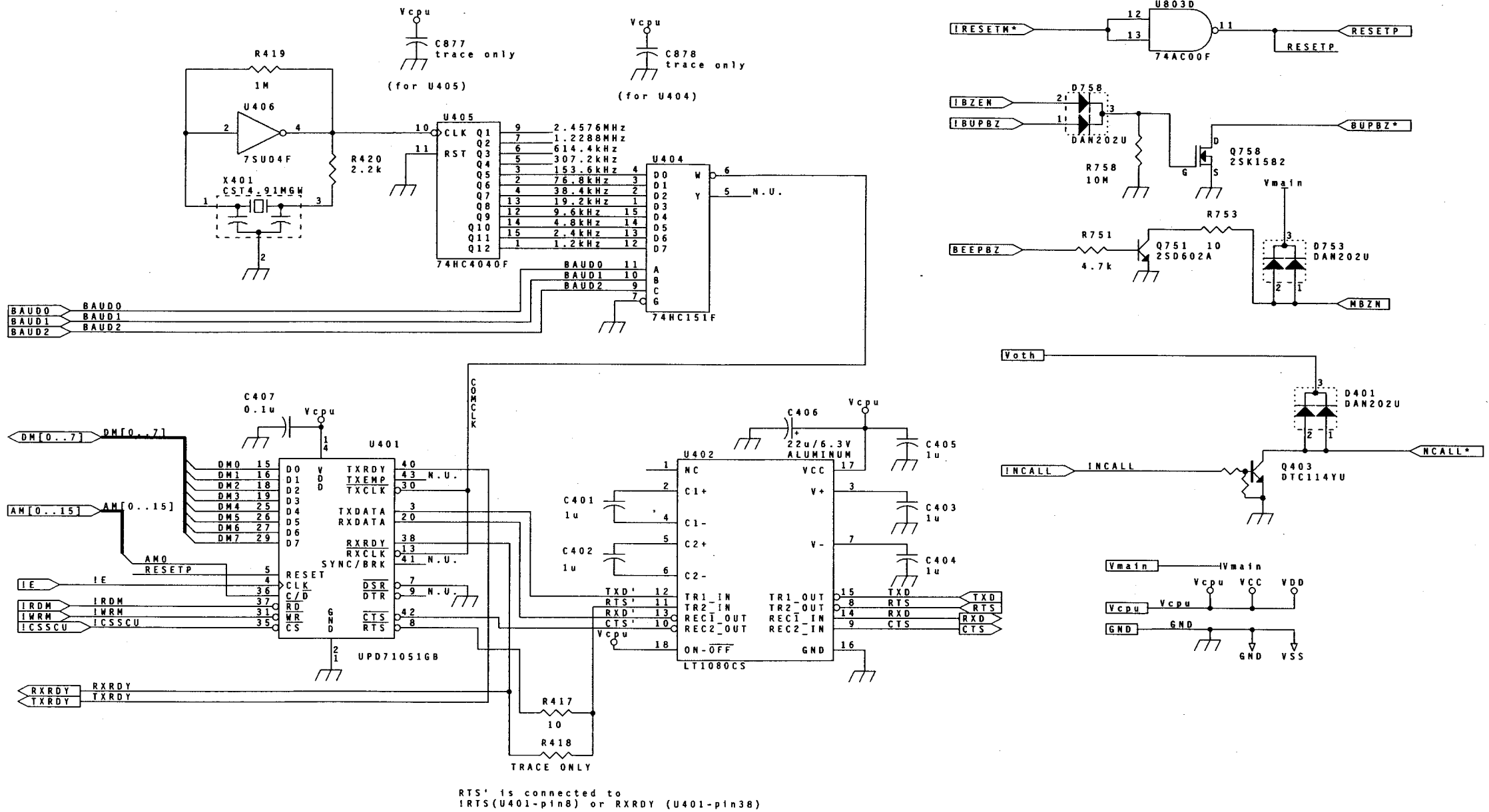

Figure 10-14. Serial Communication Block

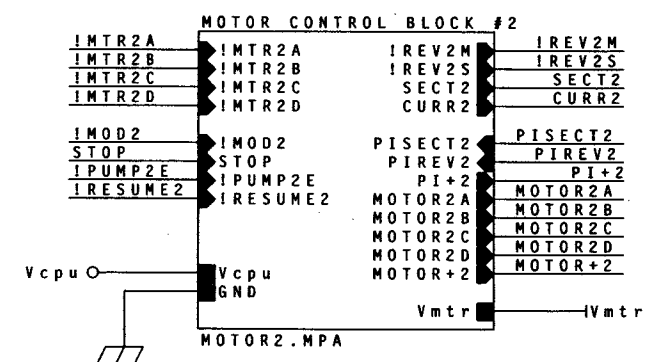
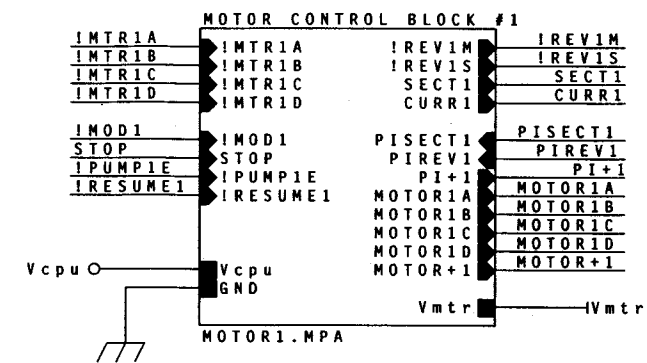
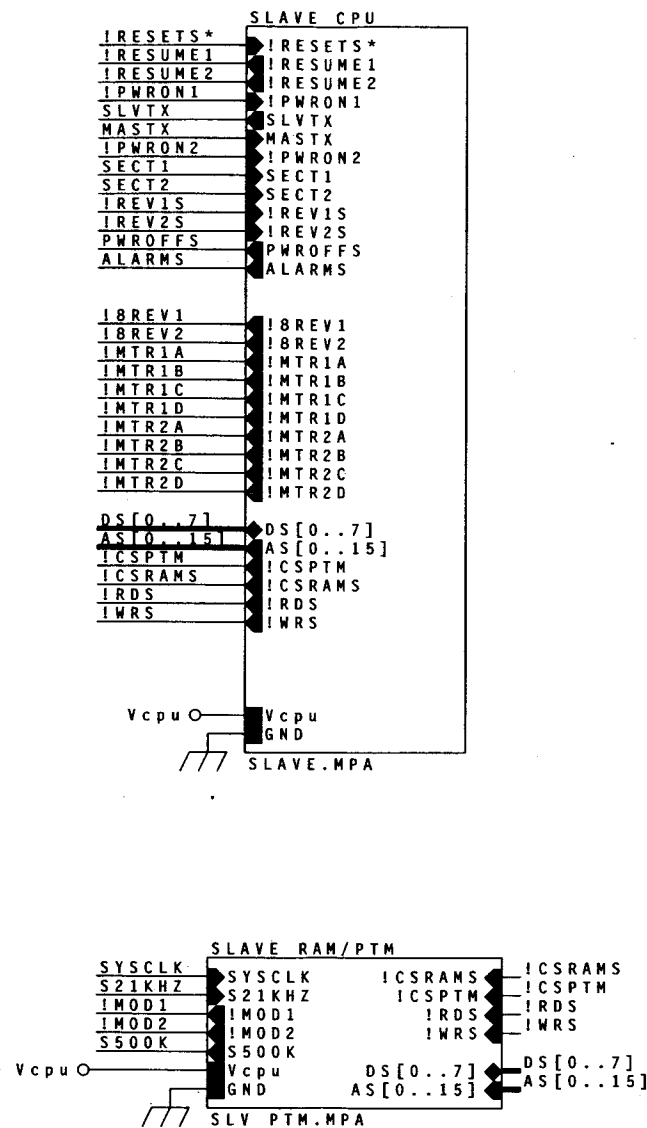
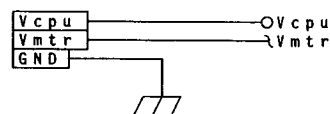
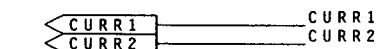
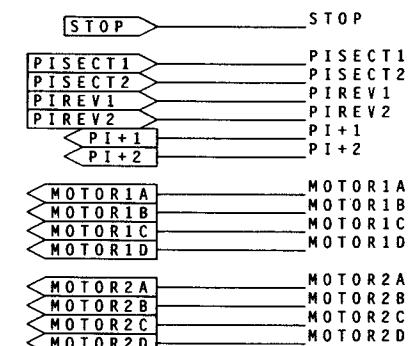
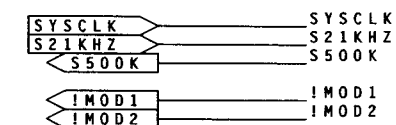
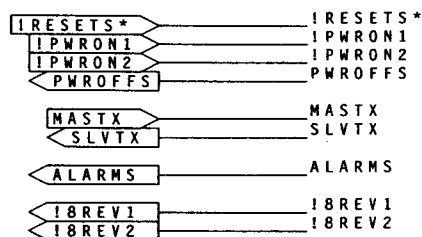

Figure 10-15. Slave CPU Block Diagram

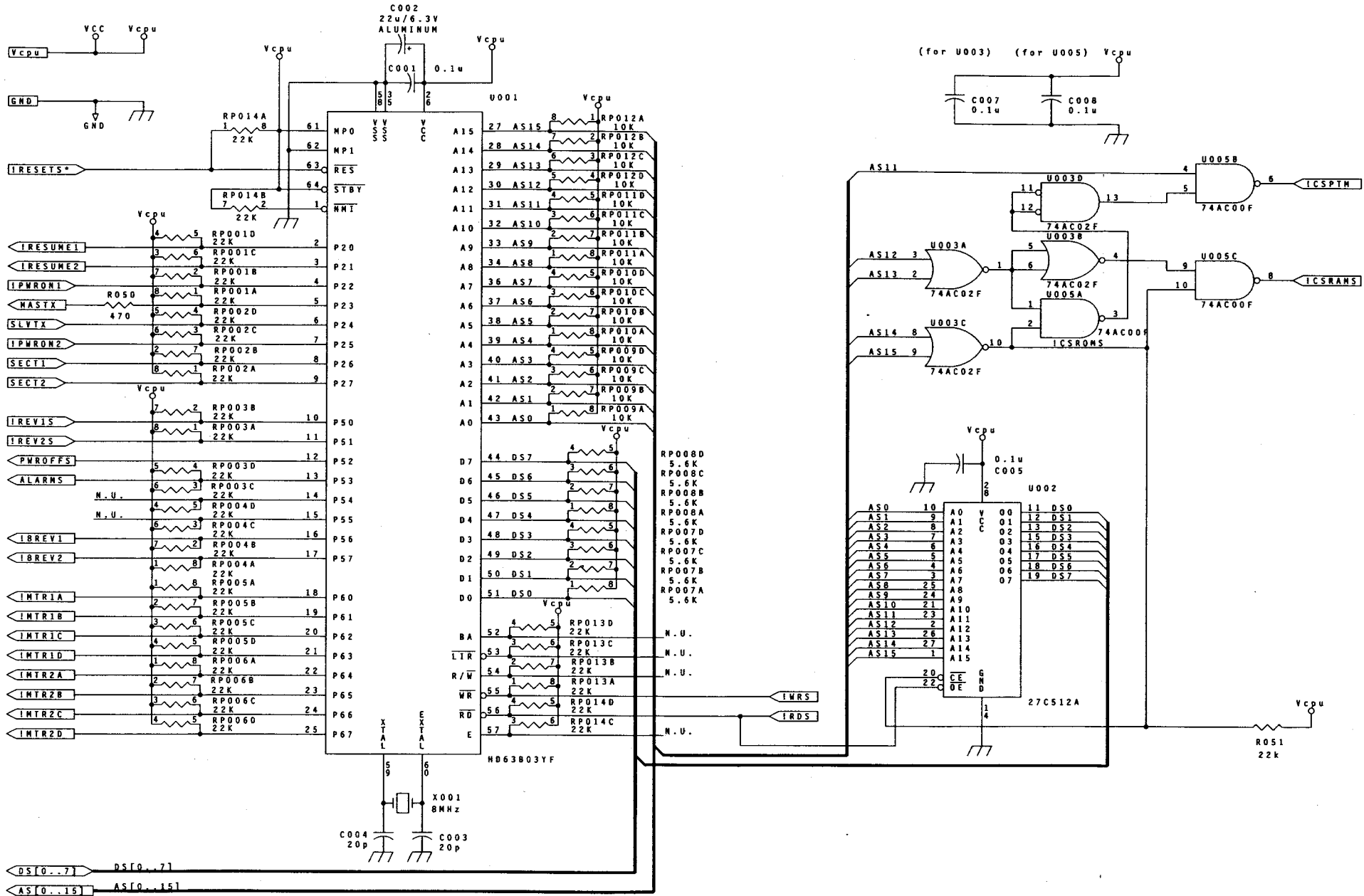

Figure 10-16. Slave CPU Schematic

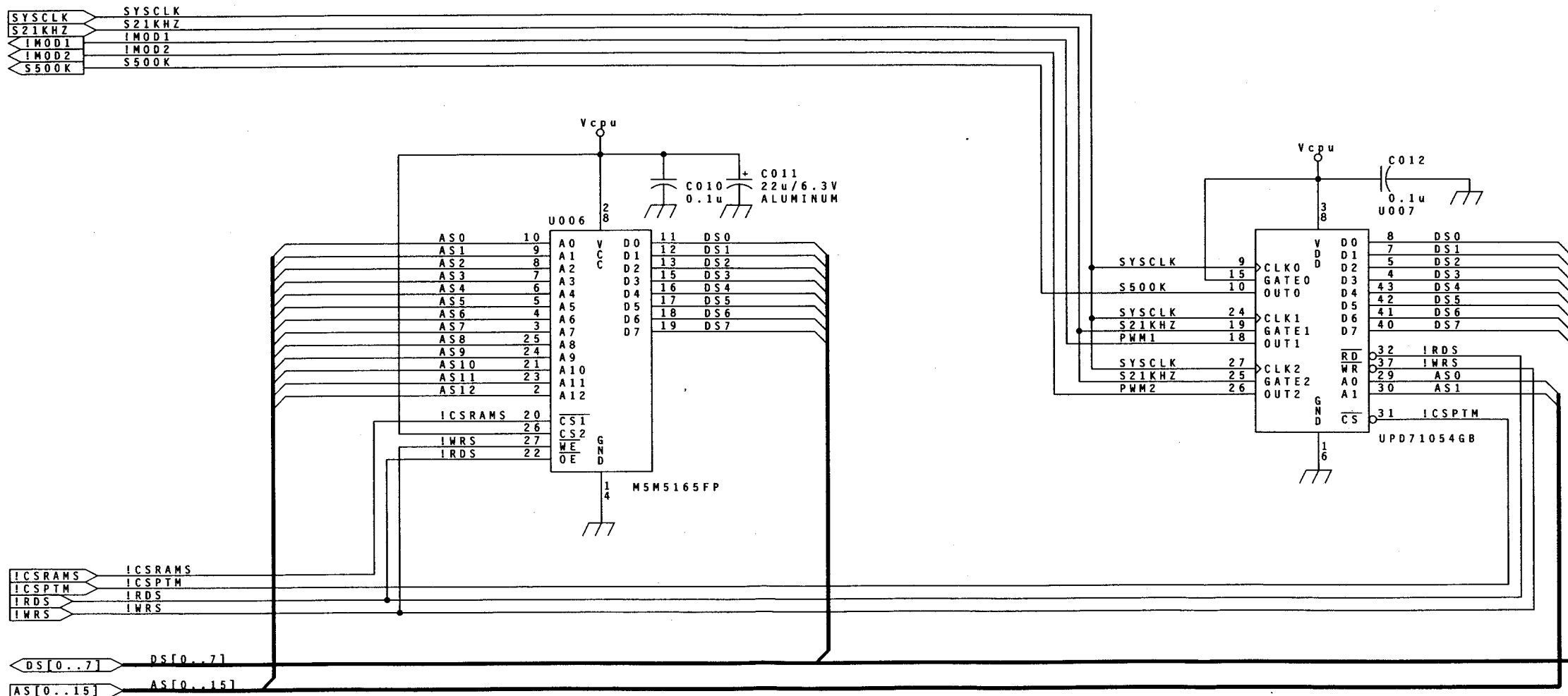
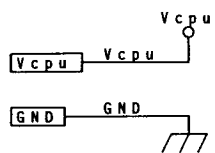

Figure 10-17. Slave RAM and Programmable Timer Module

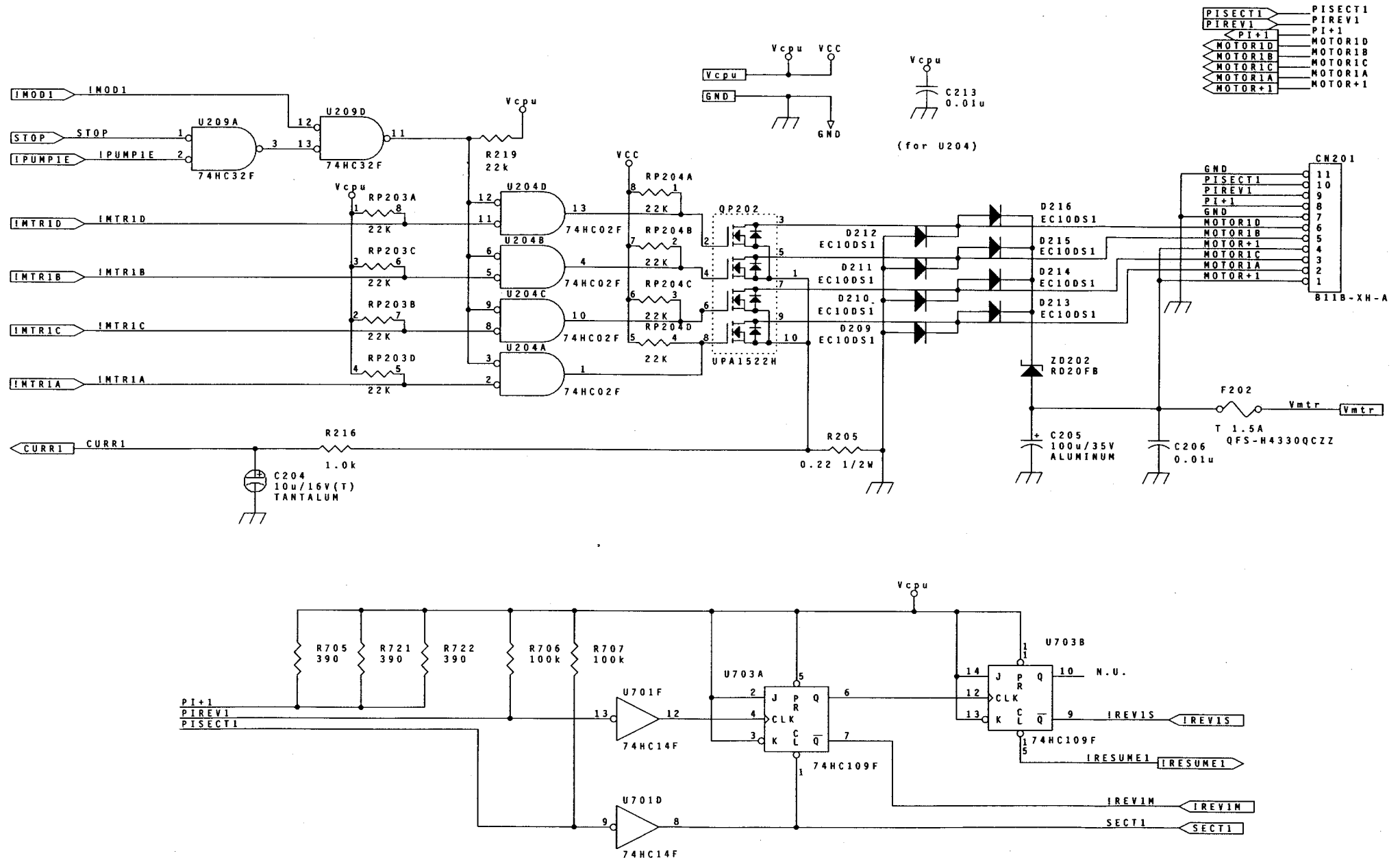

Figure 10-18. Motor Driver Circuit - Pump 1



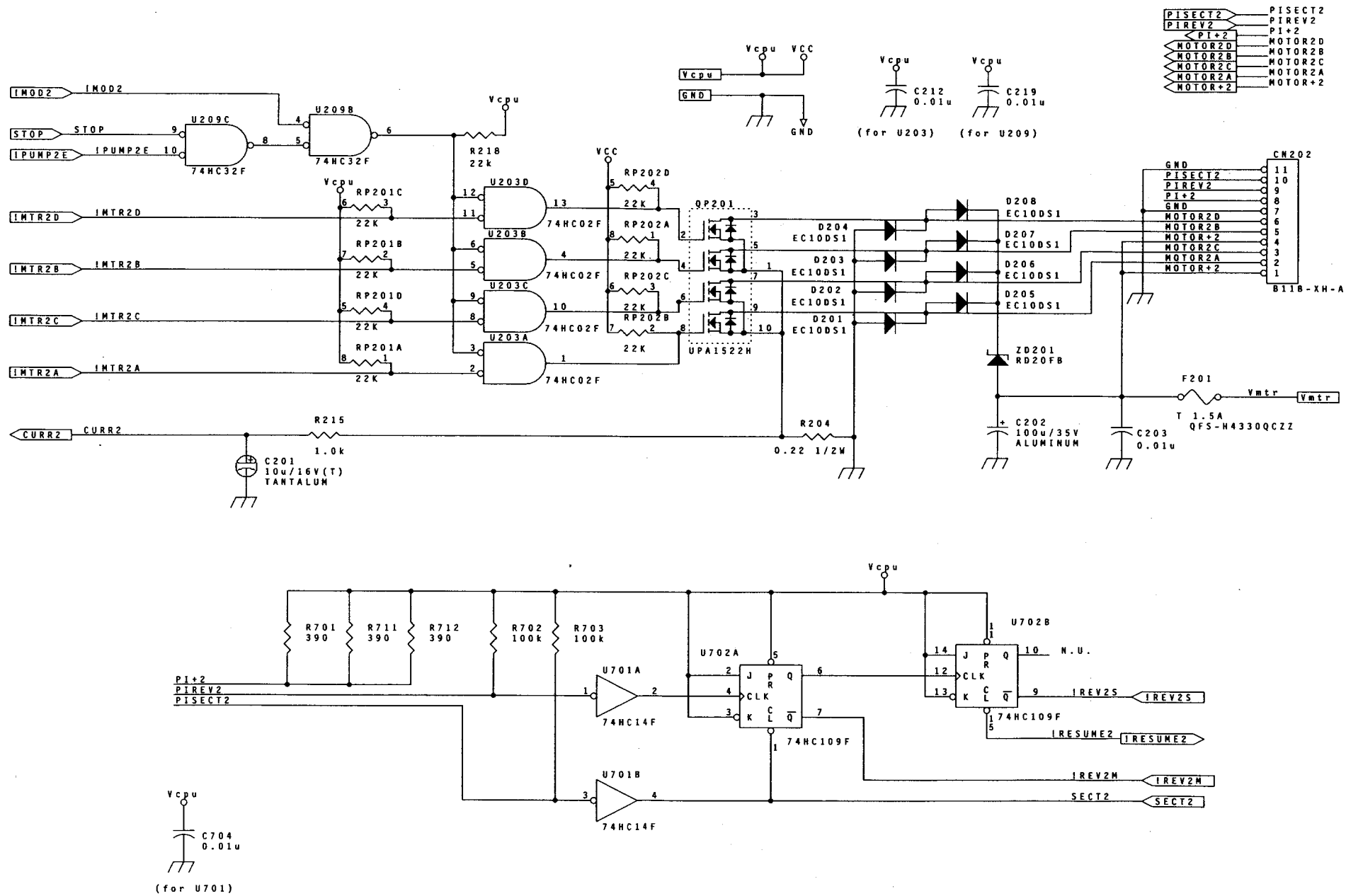

Figure 10-19. Motor Driver Circuit - Pump 2

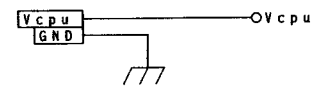
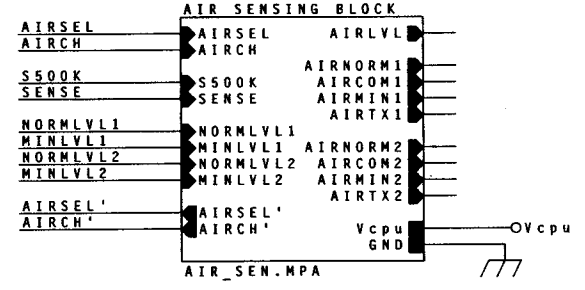
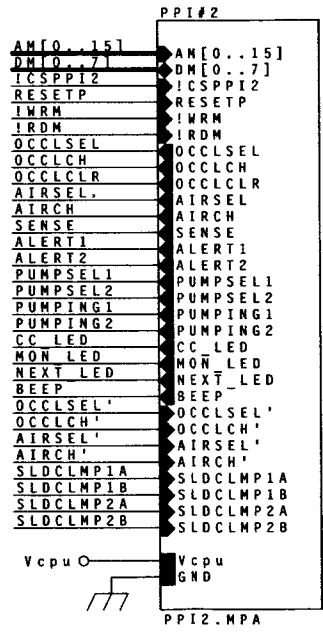
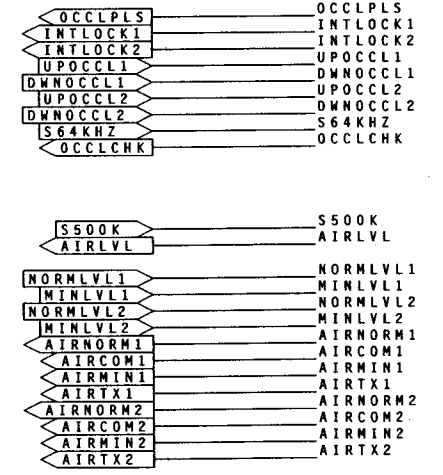
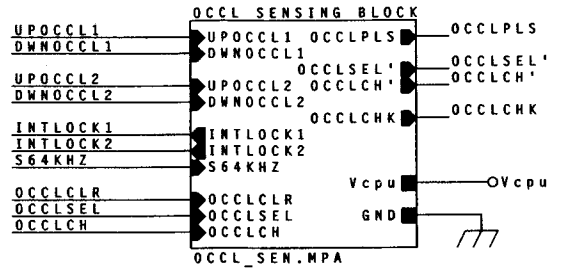
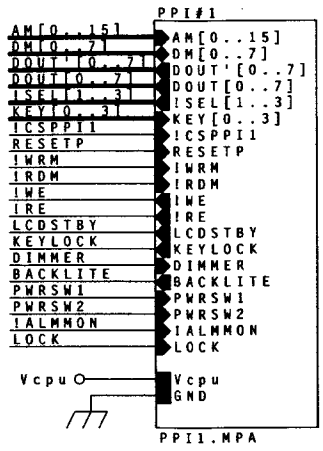
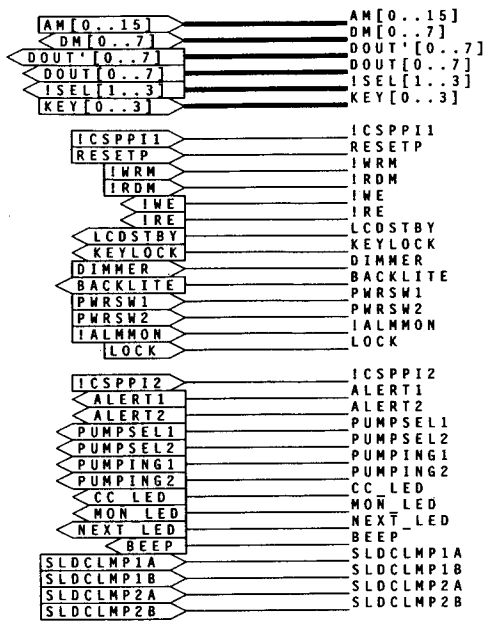

Figure 10-20. CPU PCB (Sensor Block)

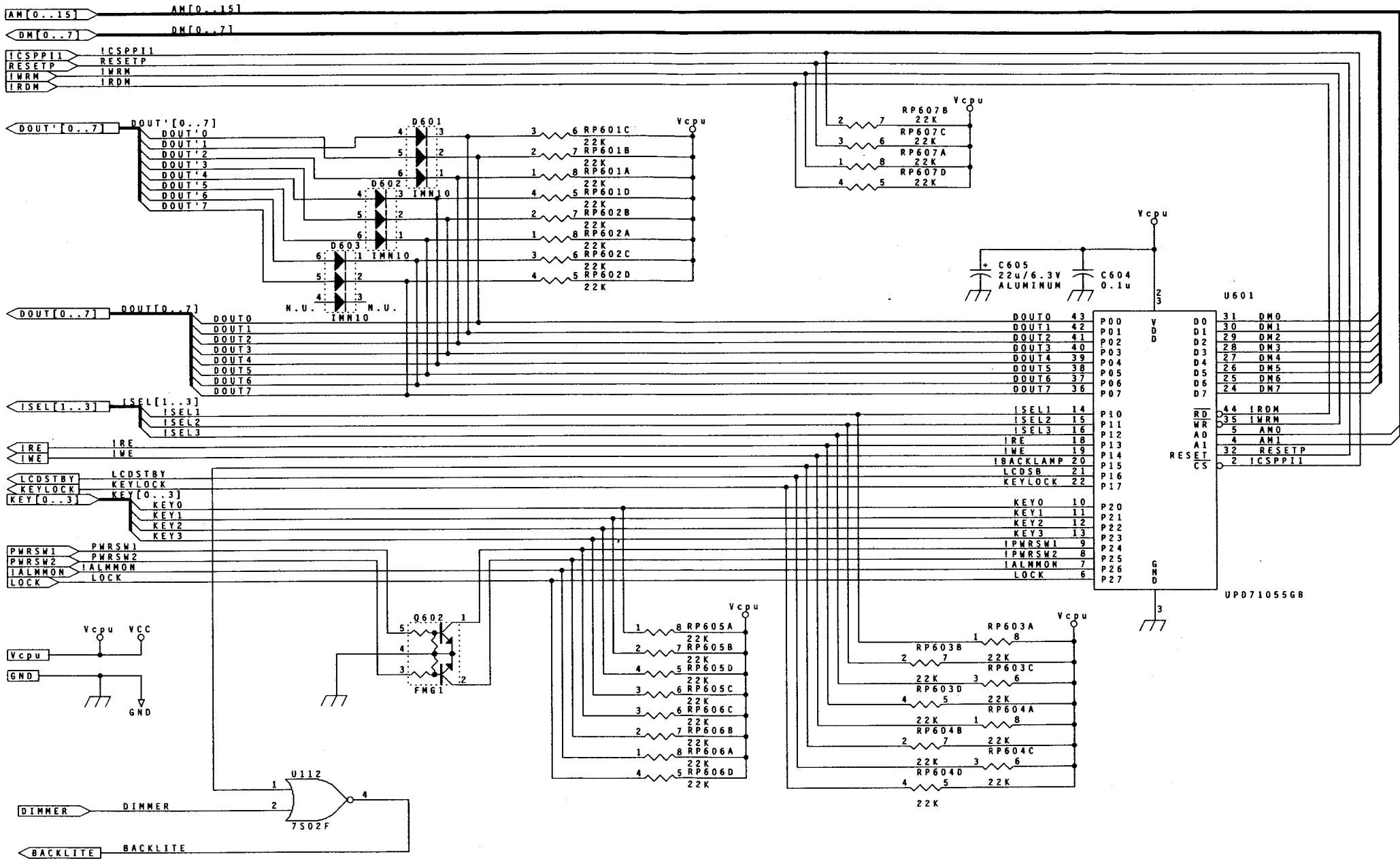

Figure 10-21. PPI Block #1

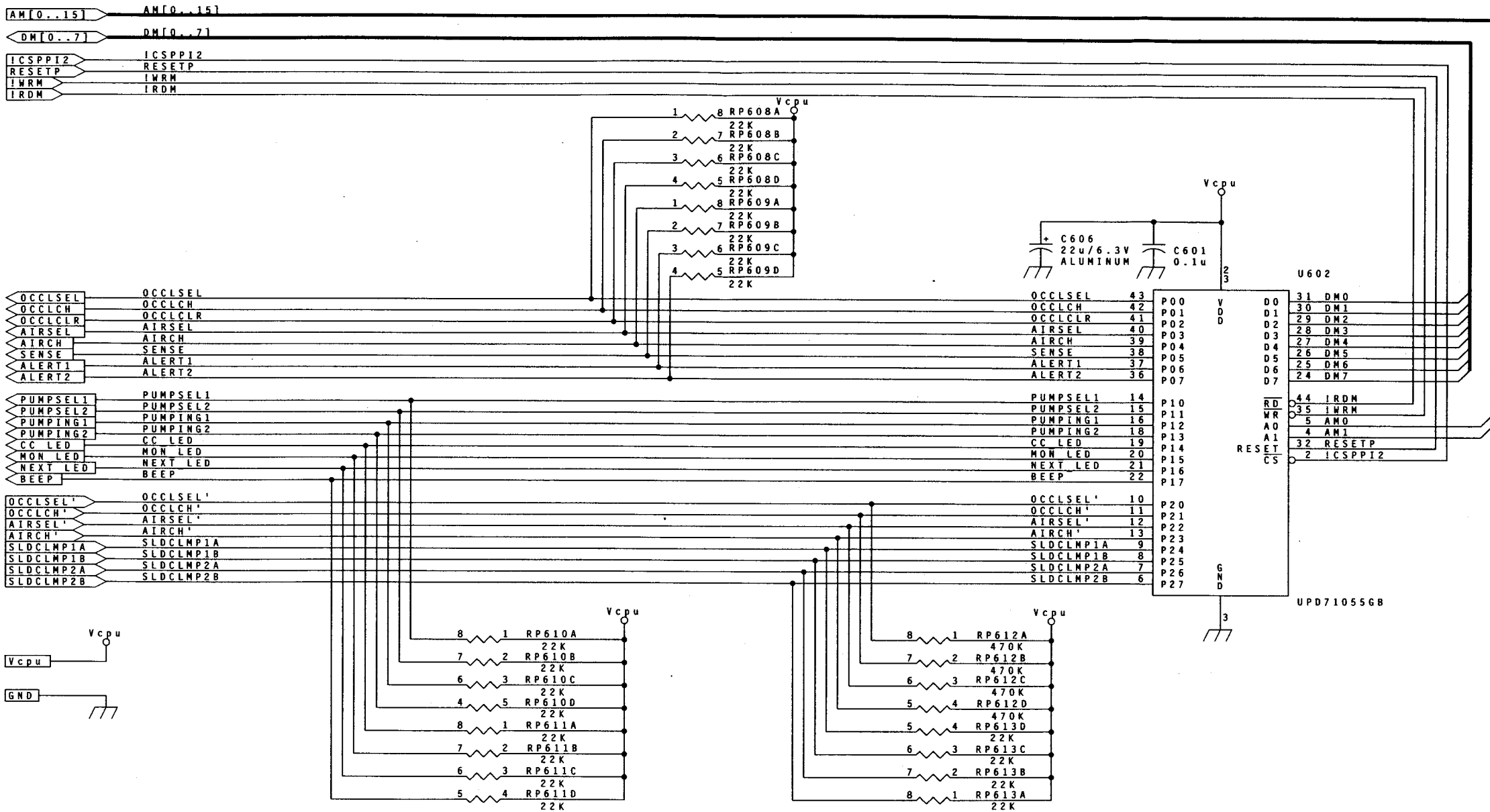

Figure 10-22. PPI Block #2



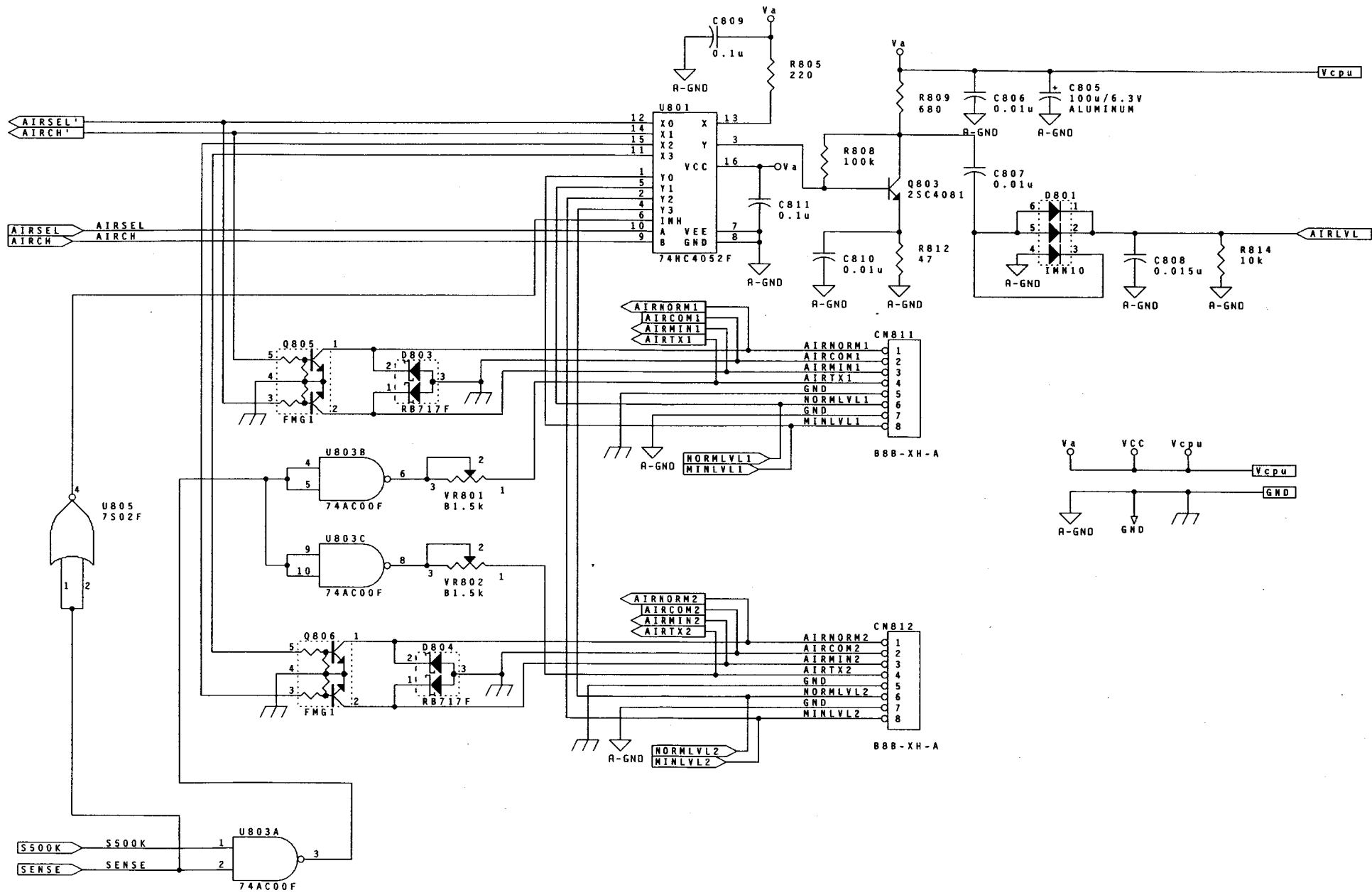

Figure 10-24. Air Sensing Block

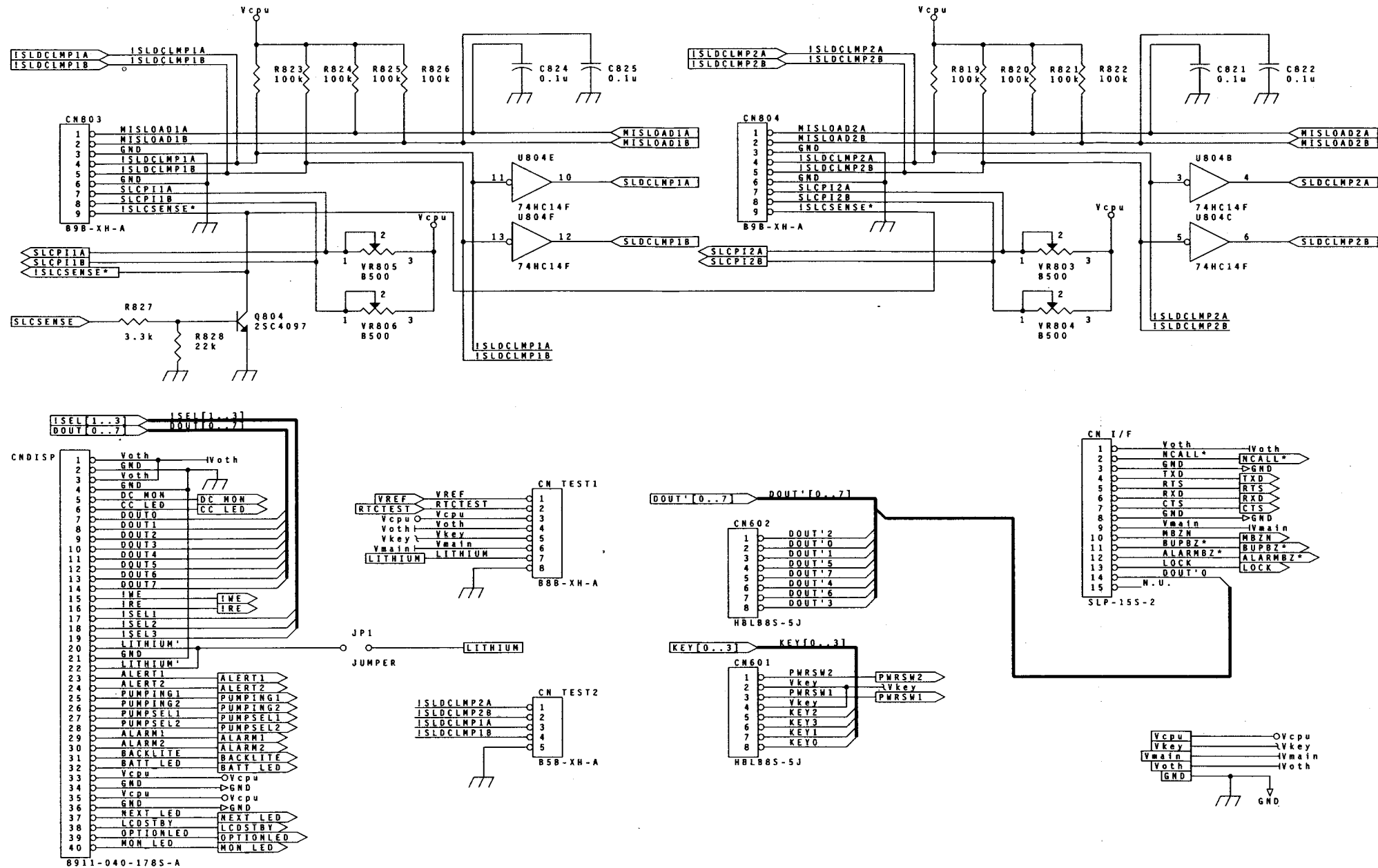

Figure 10-25. Misload and Slide Clamp Sensors

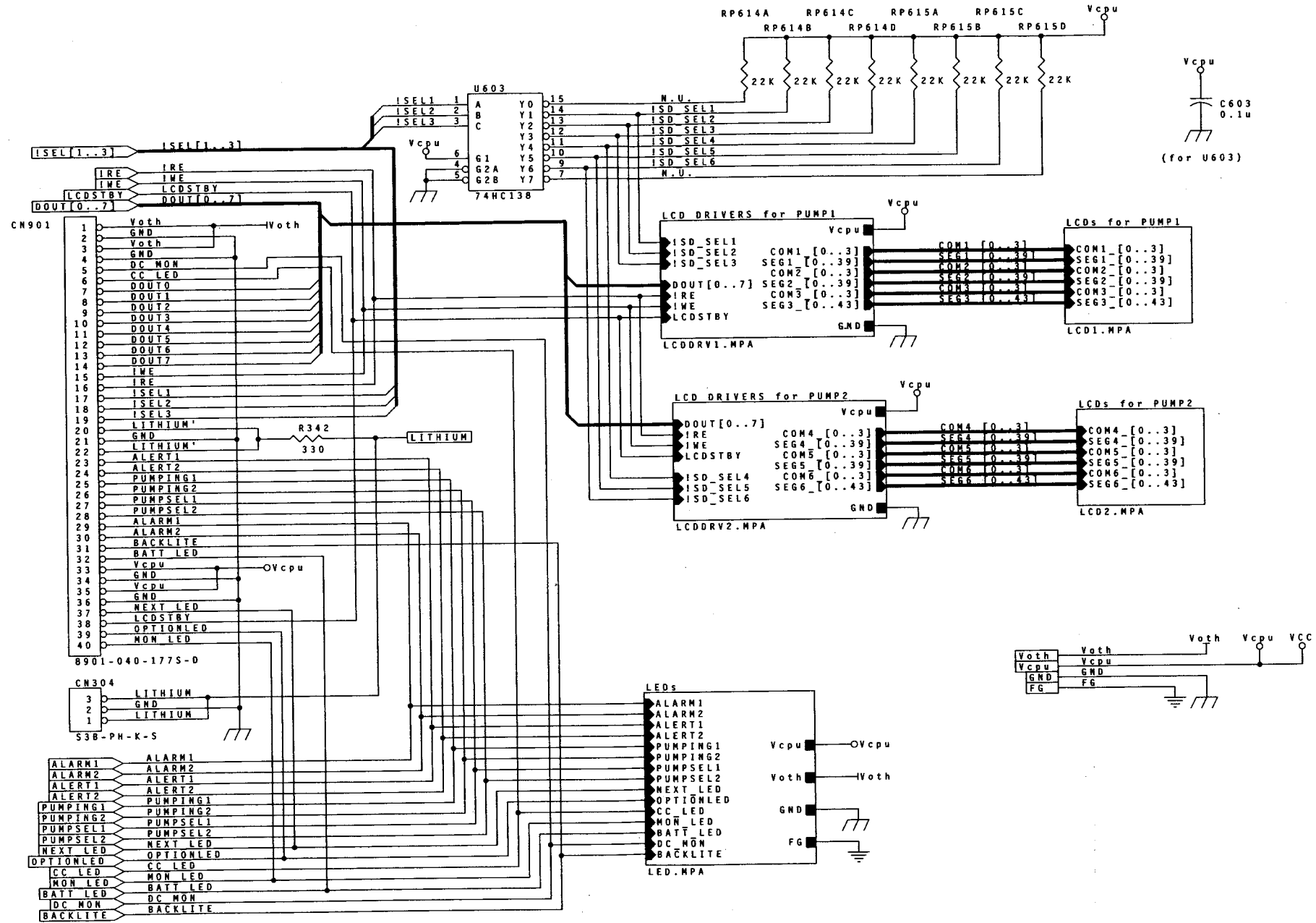

Figure 10-26. Display PCB



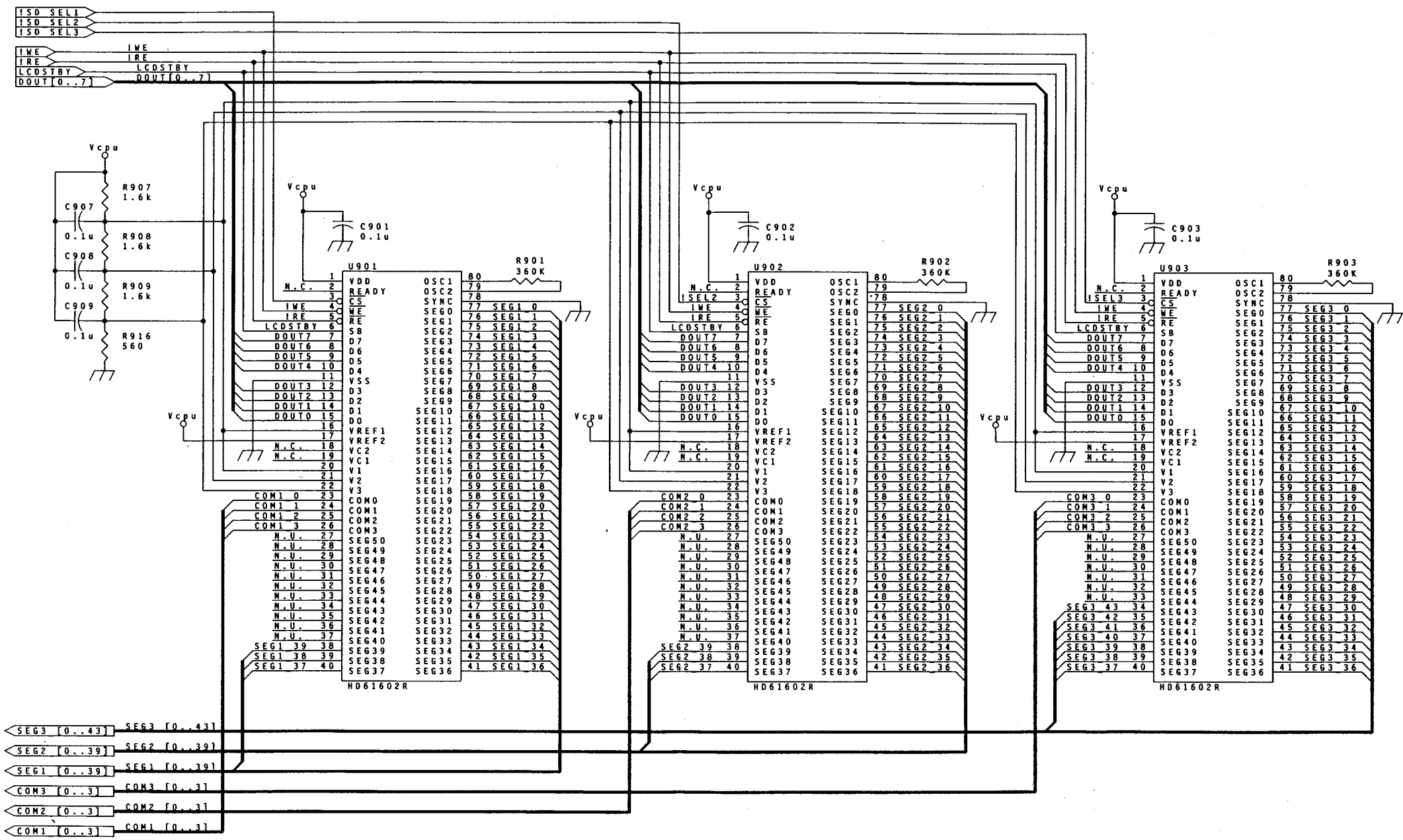

Figure 10-27. LCD Drivers for Pump 1

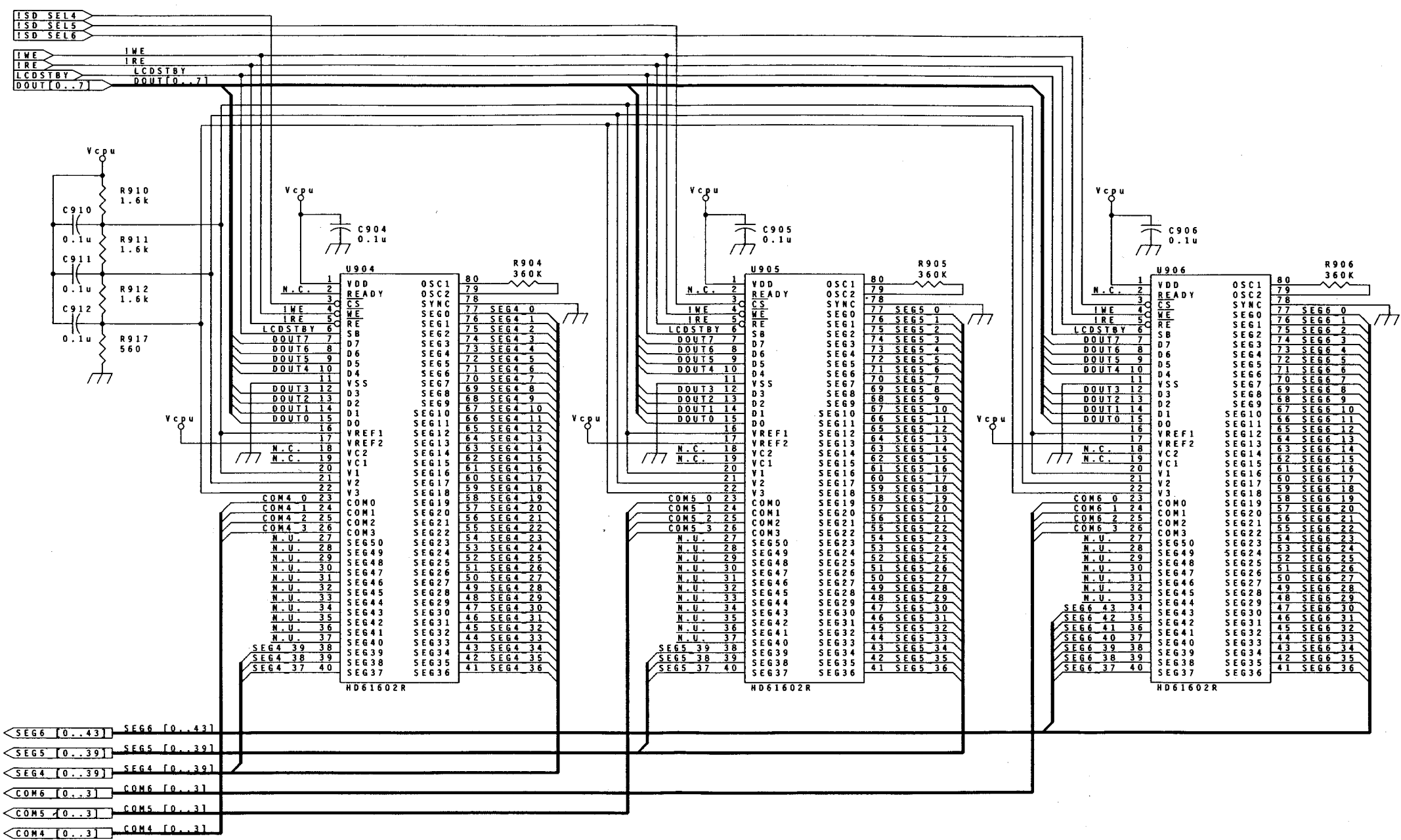

Figure 10-28. LCD Drivers for Pump 2

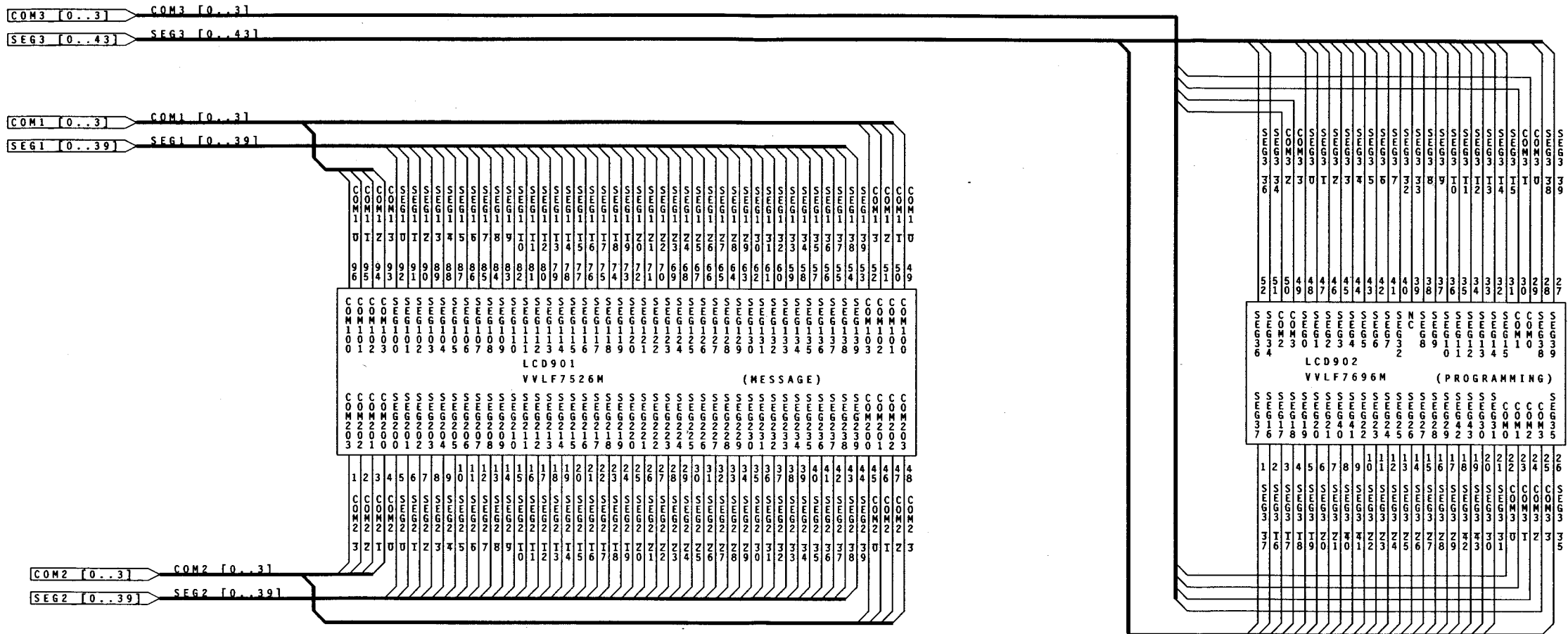

Figure 10-29. LCDs for Pump 1



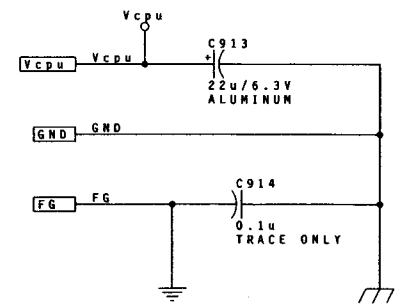
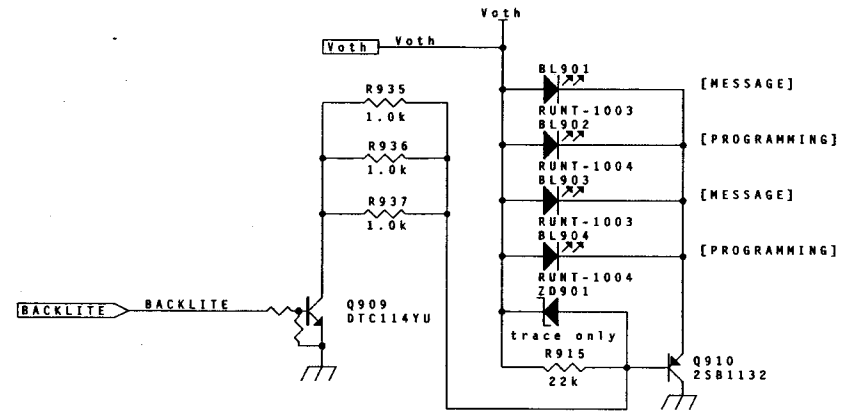
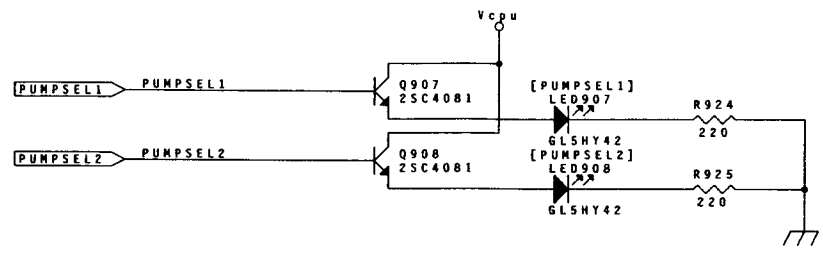
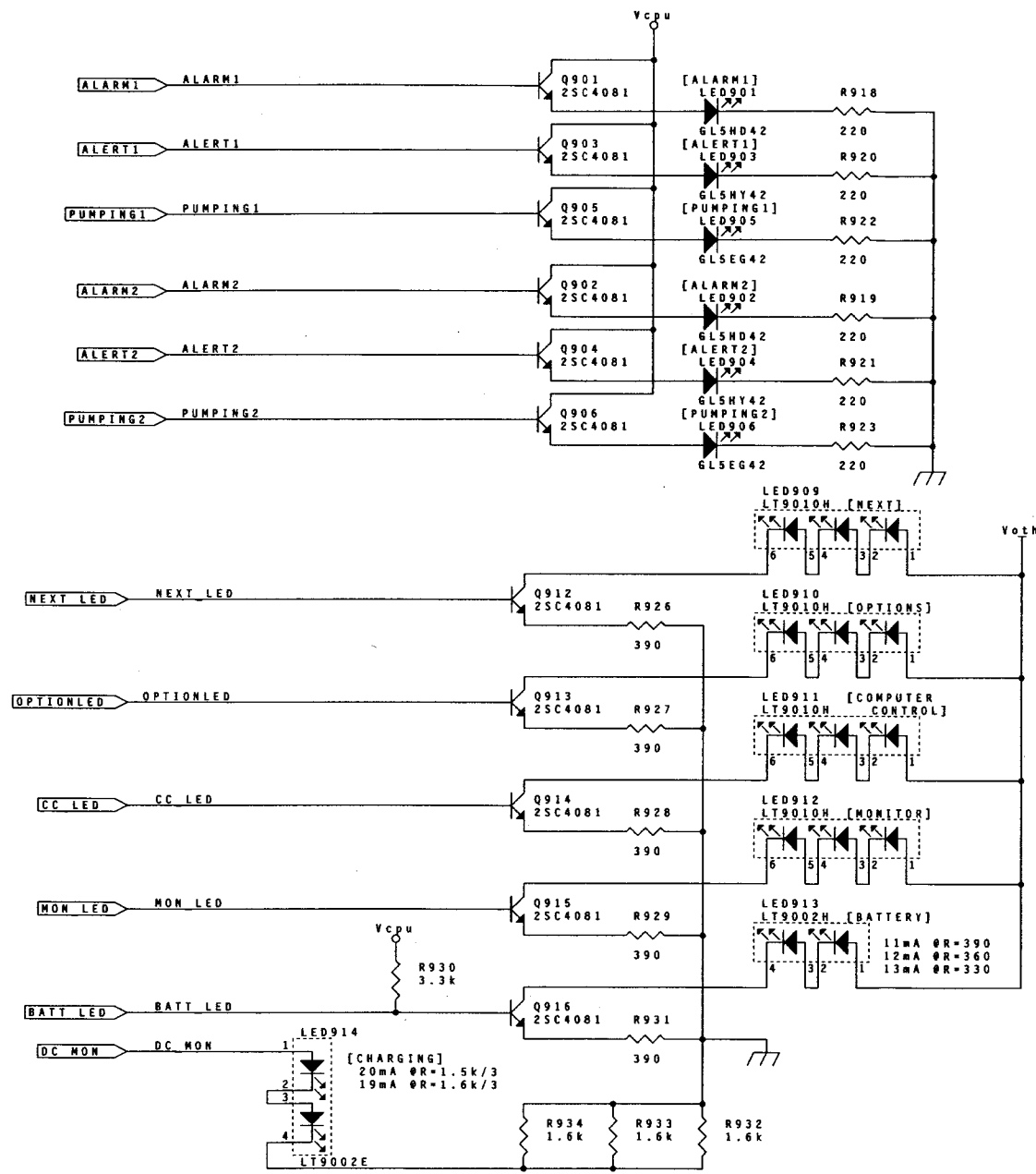

Figure 10-31. LED Lamps

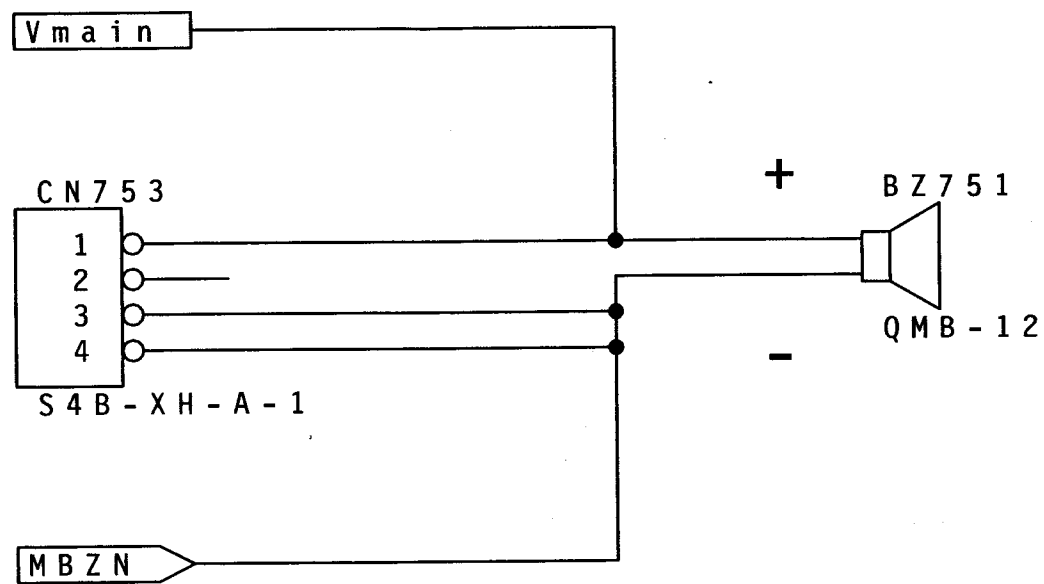
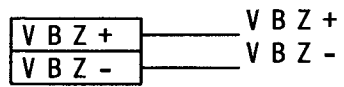

Figure 10-32. Audible Alarm PCB



Pin #1 of CN751 is connected to GND via wire harness. But true GND line is VBZ-.

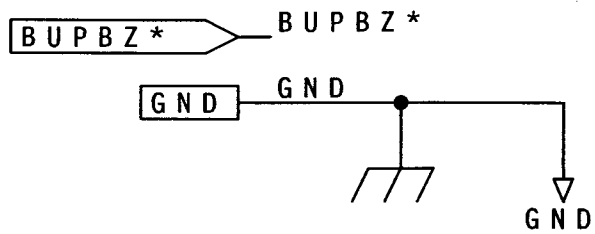
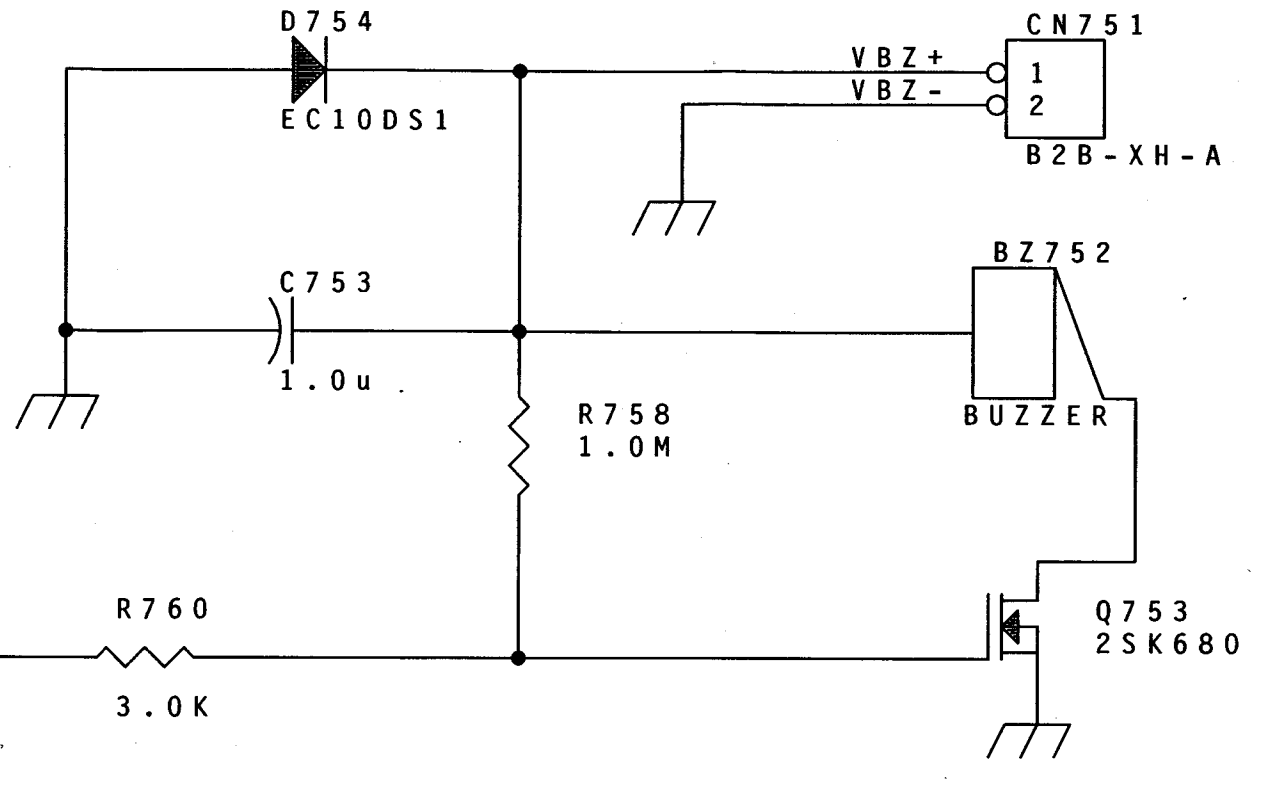
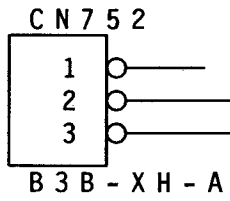

Figure 10-33. Backup Buzzer PCB

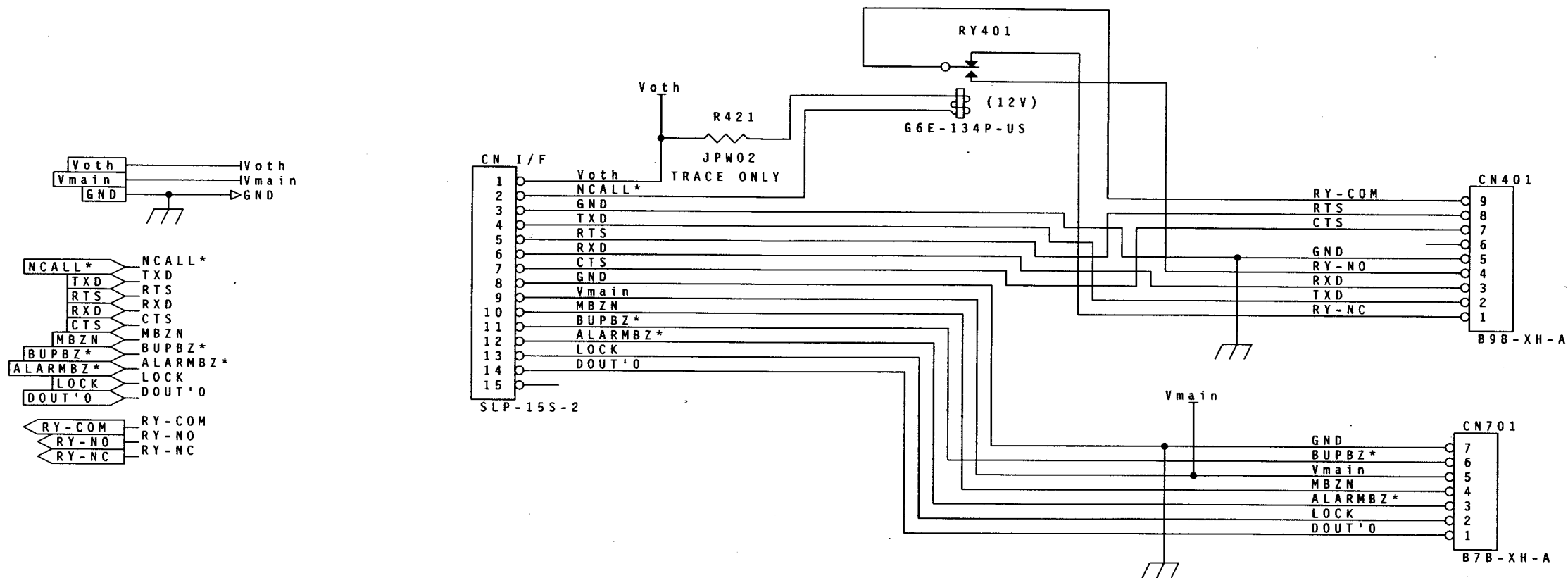
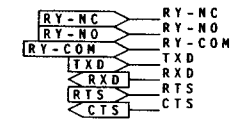
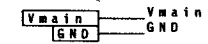
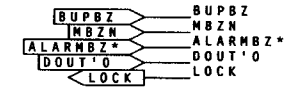
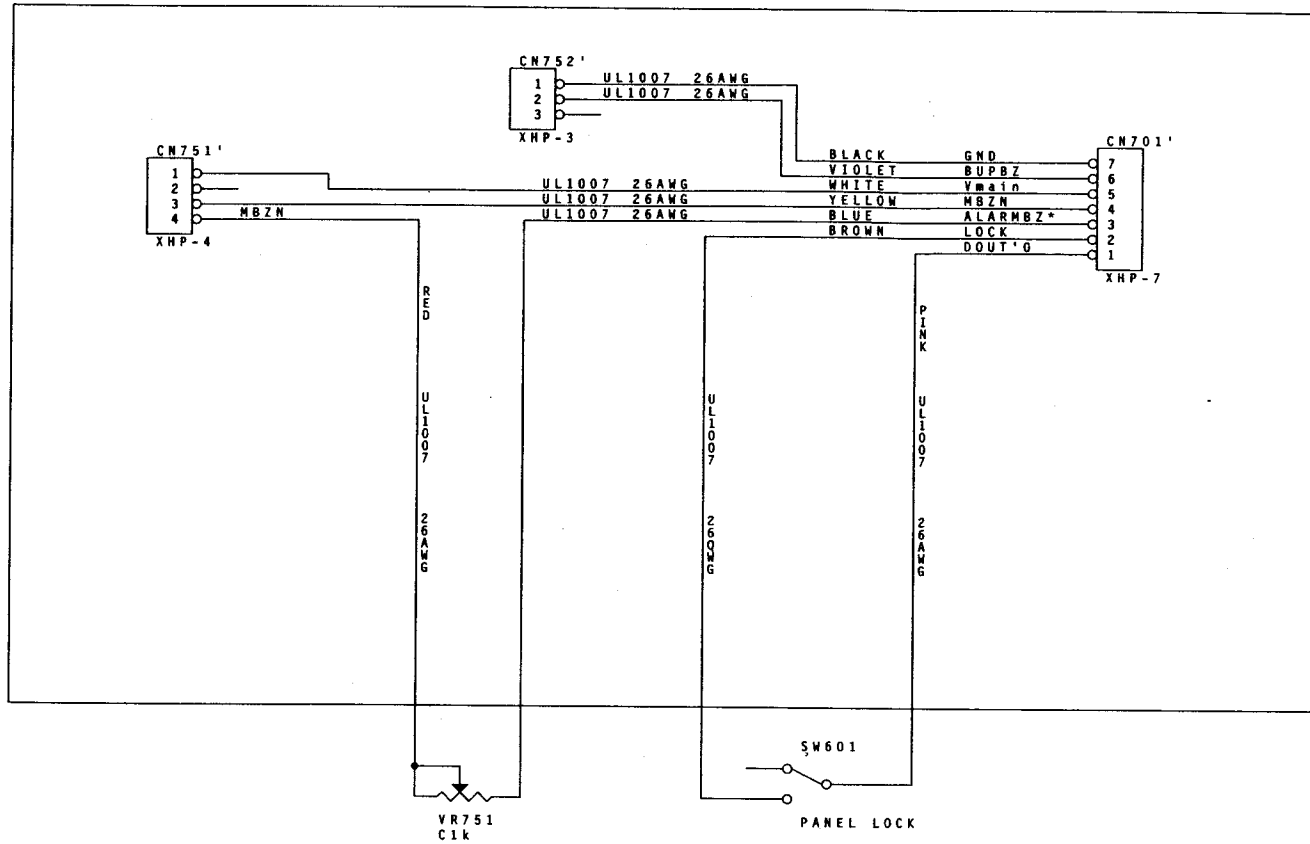

Figure 10-34. Terminal PCB



QC NW - 1114 MC



QC NW - 1092 MC

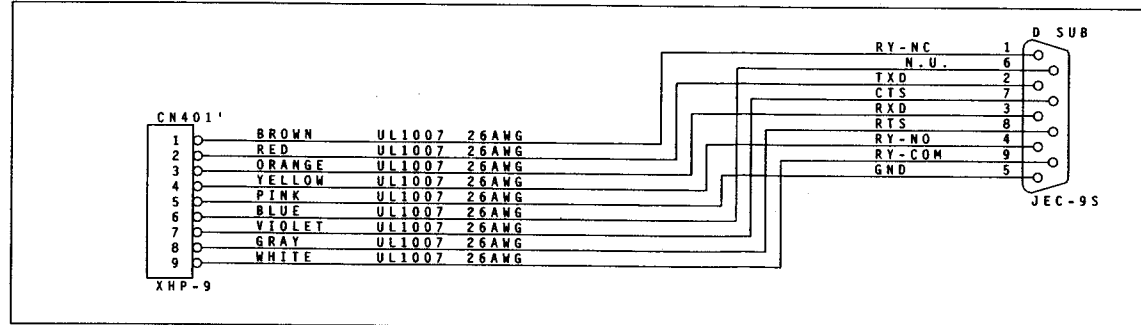

Figure 10-35. Accessories

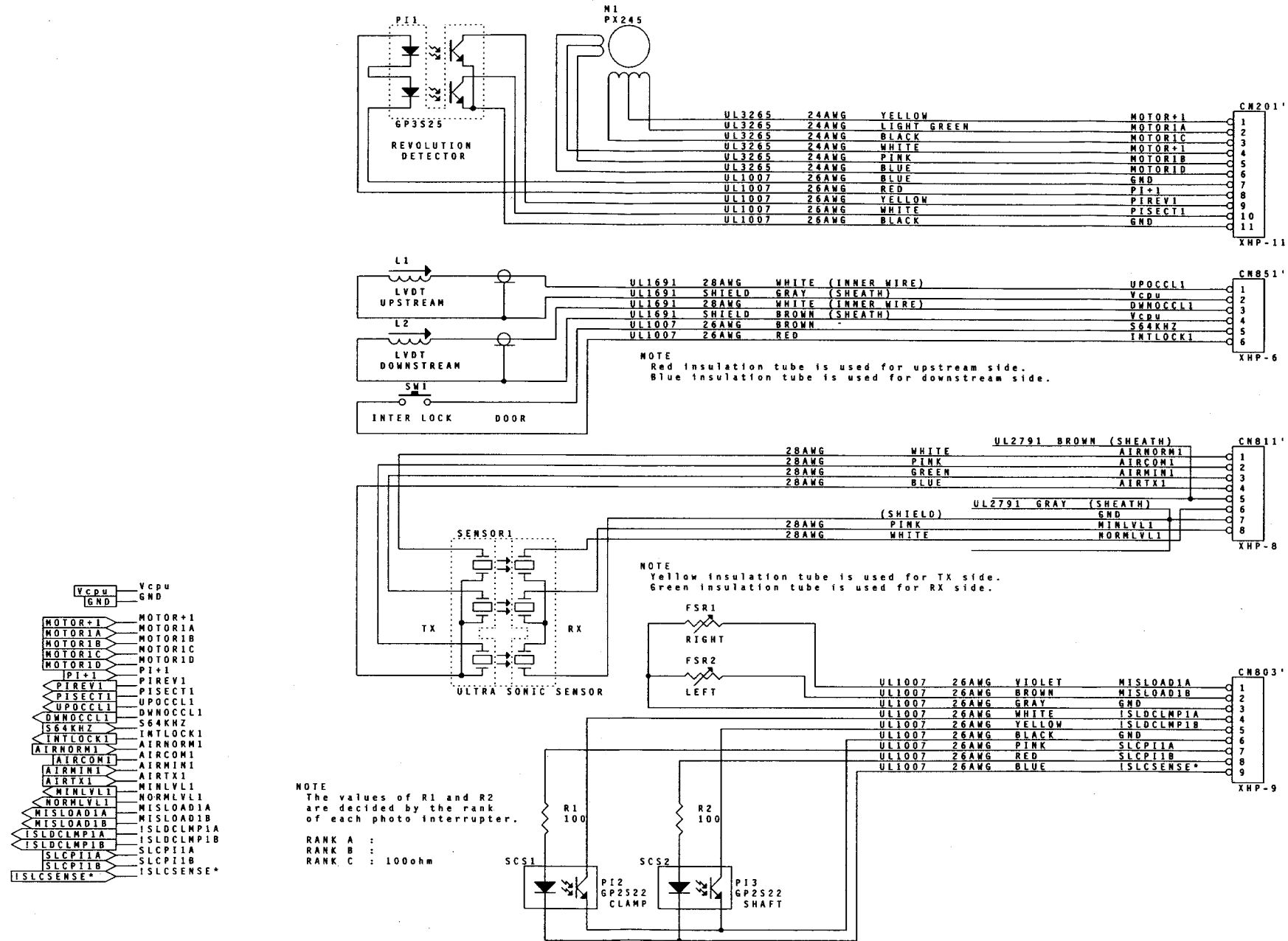

Figure 10-36. Sensors on Pumphead 1

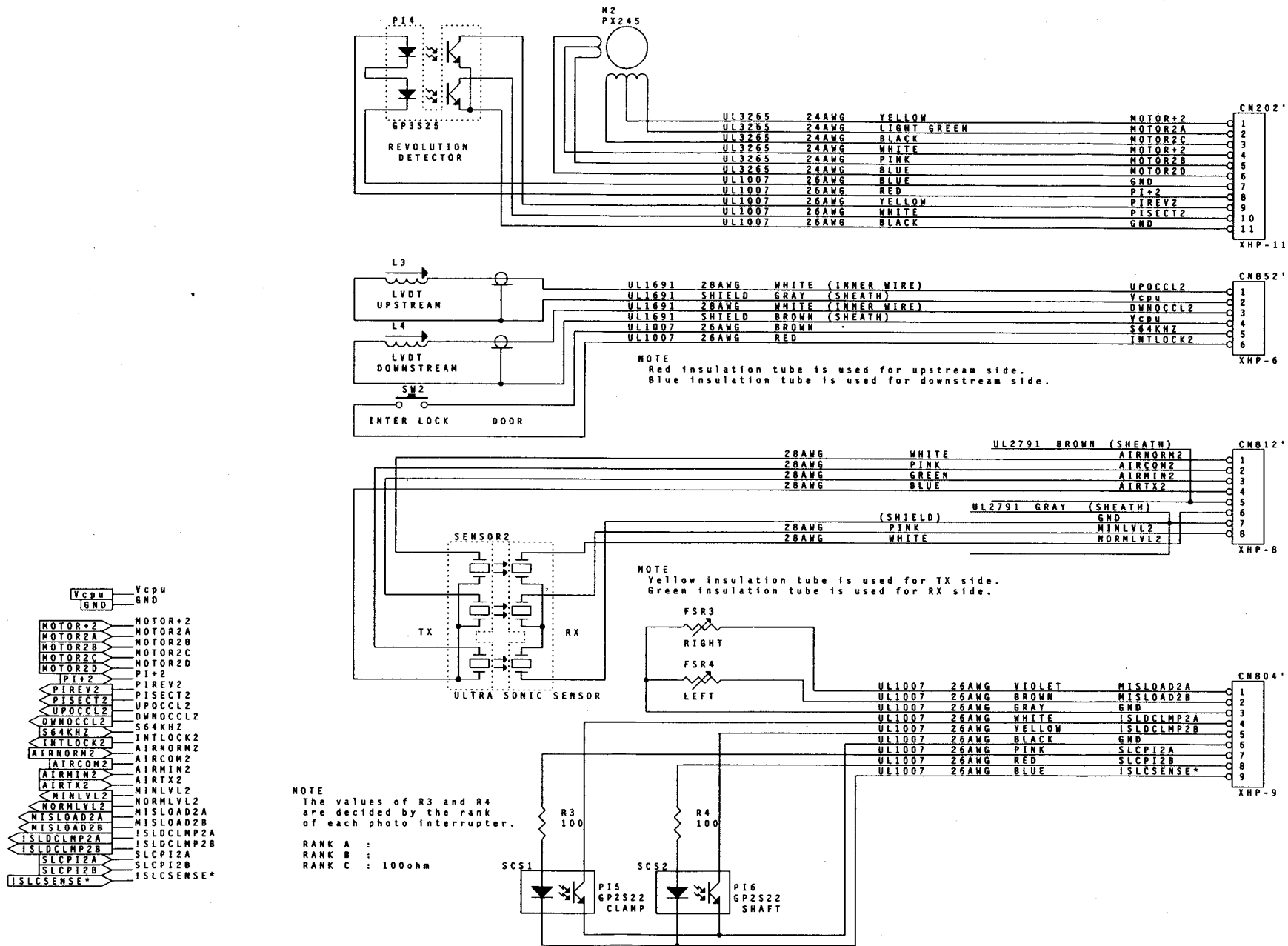

Figure 10-37. Sensors on Pumphead 2

	DOUT7'	DOUT6'	DOUT5'	DOUT4'	DOUT3'	DOUT2'	DOUT1'	DOUT0'
KEY3					STOP2	PUMP2	STOP1	PUMP1
KEY2	.	SEC START	SEC VTBI	SEC RATE	OPTIONS	PRI START	PRI VTBI	PRI RATE
KEY1	8	9	TIME	CLEAR	BACK LIGHT	SILENCE	CLEAR TOT VOL	TOT VOL STATUS
KEY0	0	1	2	3	4	5	6	7

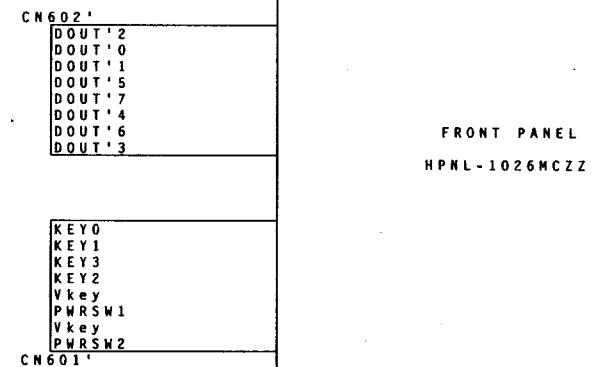
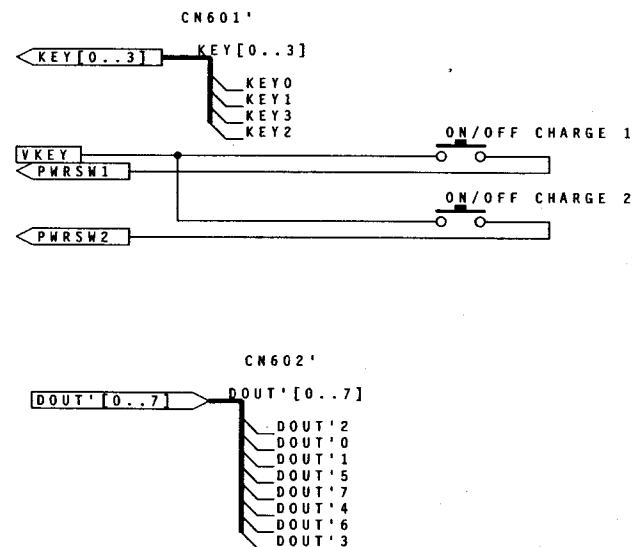

Figure 10-38. Front Panel Key Assignments

# Appendix A

## Data Sheet, Flo-Gard® 6301 Volumetric Infusion Pump (2M8064)

This data sheet should be used to record the results obtained when performing the Operational Checkout of the device. The configuration option settings can also be recorded.

Device Serial Number \_\_\_\_\_

### Configuration Option Settings

Options	Factory Set Values	Modified Configuration to:
OCCLUSION	1: LEVEL 1	1 ( ) 2 ( ) 3 ( )
AUDIB SWI	1: OFF	ON ( ) OFF ( )
AUTO RES	3	
DOOR OPEN	1: OFF	ON ( ) OFF ( )
AIR SIZE	1: NORM	NORM ( ) MIN ( )
ALARM INT	1	
ALERT INT	7	
MAX RATE	1999	
MAX VTBI	9999	
FLOW CHECK	1: OFF	ON ( ) OFF ( )
BAUD RATE	5: 9600	
COMP CONT	1: DISABLED	DISABLED ( ) OFF W ALRM ( ) ON W ALRM ( )
HAD	0: no message	
CLOSE CLMP	2: ON	OFF ( ) ON ( )
INS CLAMP Note: Alert or alarm option available only on pumps running software versions 1.09 or later.	1: OFF	OFF ( ) ON ( ) for software versions earlier than 1.09 ALERT ( ) for software versions 1.09 or later ALARM ( ) for software versions 1.09 or later
PDP	1: DISABLED	DISABLED ( ) FIVE HOUR ( ) SEMI PERM ( ) PERM ( )
TIME SET	Central Standard Time	
DATE SET	Current date for Central Standard Time	

### Operational Checkout - Section 7

Paragraph	Test	Results			
		Pump 1		Pump 2	
7.3.2.2	Self-Test	Pass	Fail	Pass	Fail
7.3.2.3	Primary Infusion Test	Pass	Fail	Pass	Fail
7.3.3	<b>DOOR OPEN</b> message and audible alarm occur when door is opened during infusion	Pass	Fail	Pass	Fail
7.3.4	Pump alarms for air bubble NORM >110 µL ( ) or MIN > 85 µL ( )	Pass	Fail	Pass	Fail
7.3.5	Drive defect/Occlusion check	Pass	Fail	Pass	Fail
7.3.6	Downstream occlusion detected	Pass	Fail	Pass	Fail
7.3.6	Downstream Occlusion Sensor Calibration Value (2967 - 3039 with thickness gauge in place)	Pass	Fail	Pass	Fail
7.3.7	Upstream occlusion detected	Pass	Fail	Pass	Fail
7.3.7	Upstream Occlusion Sensor Calibration Value (3242 - 3314 with thickness gauge in place)	Pass	Fail	Pass	Fail
7.3.7	Upstream Occlusion Sensor Calibration Value (3180 or less without thickness gauge installed)	Pass	Fail	Pass	Fail
7.3.8	<b>BATTERY</b> appears when device is unplugged during operation and the pump continues to operate while unplugged	Pass	Fail		
7.3.8.2	<b>BATTERY</b> disappears when the device is plugged back in	Pass	Fail		
7.3.9	<b>Loc</b> message appears when PANEL LOCK switch is pressed	Pass	Fail	Pass	Fail
7.3.9	Input from front panel keys is not accepted while panel lock is in effect	Pass	Fail	Pass	Fail
7.3.9	<b>Loc</b> message disappears when PANEL LOCK switch is pressed again and input from keypad is accepted	Pass	Fail	Pass	Fail
7.3.10	Safety clamp prevents free flow	Pass	Fail	Pass	Fail
7.3.11	Sound level increases as VOLUME knob is rotated clockwise and decreases as knob is rotated counterclockwise.	Pass	Fail	Pass	Fail
7.3.11	Alarm/alert sound audible at any VOLUME knob position	Pass	Fail	Pass	Fail
7.3.12	Slide clamp enabled	Yes	No		
7.3.12	If the slide clamp option is enabled, slide clamp operates correctly	Pass	Fail	Pass	Fail
7.3.12	If the slide clamp option is disabled, spring retainer occupies slide clamp slot	Pass	Fail	Pass	Fail
7.3.13	Leakage current is <b>50 microamps or less</b>	Pass	Fail		
7.3.13	Ground impedance is <b>0.15 ohm or less</b>	Pass	Fail		

### Air Sensor Calibration Values - Section 5.3.2

Descriptor	Window Displayed	Acceptable Value	Tubing Loaded Pump Door Closed	Results			
				Pump 1		Pump 2	
NORM and MIN	PRI RATE and PRI VTBI	330-565 (new)	Yes	Pass	Fail	Pass	Fail
NORM and MIN	PRI RATE and PRI VTBI	400-650 (old)	Yes	Pass	Fail	Pass	Fail
NORM and MIN	PRI RATE, PRI VTBI	11 or less	Yes	Pass	Fail	Pass	Fail

# Appendix B

## Multiple Key Combinations

The following multiple key combinations can be used to initiate sequences on the pump. See the appropriate sections for details regarding the proper use of these combinations. An example of the standard convention used in this table is given below.

Key combination: **LOCK + STOP + ON/OFF CHARGE**

Action: Press and hold the **LOCK** key, while simultaneously pressing the **STOP** and **ON/OFF CHARGE** key, then release all of the keys.

### Multiple Key Combinations

Sequence	Key Combination	Section
Alarm Log (Failure ID Codes)	SILENCE + TOT VOL STATUS Press CLR TOT VOL within 3 seconds. The display will scroll backwards through the alarm codes and automatically exit at the end.	5.2
Flow Check	“.” + TOT VOL STATUS When the keys are released, the display will disappear 10 seconds later.	Table 1-1
Modify Configuration	LOCK + STOP + ON/OFF CHARGE	1.5.2
View Configuration	TIME + TOT VOL STATUS	1.5.1
Software Version	SILENCE + ON/OFF CHARGE	N/A
Calibration Test Mode 1	CLR/TOT VOL + 1 + ON/OFF CHARGE	5.3.1
Calibration Test Mode 2	CLR/TOT VOL + 2 + ON/OFF CHARGE	5.3.2
Mfg. Test Mode 3	CLR/TOT VOL + 3 + ON/OFF CHARGE	5.3.3
Aging Test Mode 4	CLR/TOT VOL + 4 + ON/OFF CHARGE	5.3.4
Display Check Test Mode 5	CLR/TOT VOL + 5 + ON/OFF CHARGE	5.3.5
Time Information Test Mode 6	CLR/TOT VOL + 6 + ON/OFF CHARGE	5.3.6
Pumping Sensor Monitoring Mode 7	CLR/TOT VOL + 7 + ON/OFF CHARGE	5.3.7
Air Sensor Test Mode 8	CLR/TOT VOL + 8 + ON/OFF CHARGE	5.3.8
Elapsed Time Test Mode 9	CLR/TOT VOL + 9 + ON/OFF CHARGE	5.3.9
Downstream Occlusion Test Mode 0	CLR/TOT VOL + 0 + ON/OFF CHARGE	5.3.10





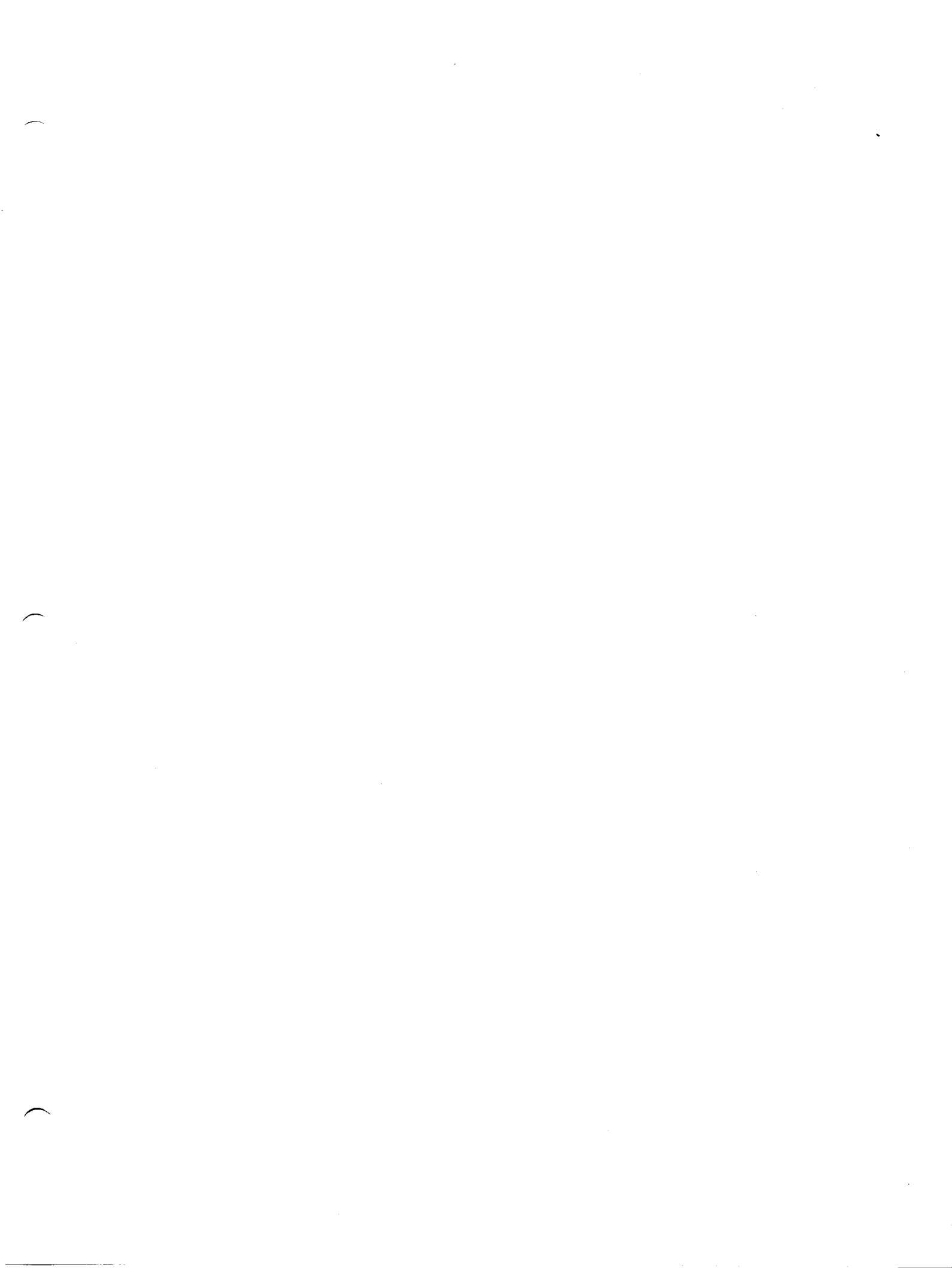

***Baxter***

**Baxter Healthcare Corporation**

Deerfield, IL 60015