

Operator's Manual

Flo-Gard[®] 6200

Volumetric Infusion Pump

Baxter

CHANGE RECORD PAGE

Specification number: 7-19-6-14A

Original Issue: 1/89

Revision A: 9/89

Page change record

Page	Revision
Cover/blank	A
Title	A
Change record page	A
1,2	0
3	A
4	0
5	A
6 through 10	0
11	A
Signature	A

Total number of pages: 16

A zero in the revision column indicates original issue.

Introduction

The Baxter Flo-Gard® 6200 Volumetric Infusion Pump can deliver a wide variety of fluids, including blood, over a broad range of infusion rates. The pump's features include:

- Easy to load, spill-resistant pumping mechanism.
- Occlusion sensors that detect both upstream and downstream restrictions.
- Ultrasonic air detector that senses bubbles approximately 50 microliters or larger without nuisance alarms.
- Safety clamp mechanism that prevents accidental free flow.
- Locking control panel that prevents tampering.
- Independent secondary medication program that automatically switches over to primary program upon completion.
- Uses standard Baxter solution administration sets.
- Automatic self-test routine that checks for proper function before use.
- Five hour memory which retains infusion data after power-off.
- Easily replaceable fuse, battery, and power cord.

Technical Specifications

Catalog Code Number	2M8043
Description	Linear peristaltic volumetric infusion pump
Administration Set	Baxter Standard administration sets with "s" suffix
Output Pressure	Initial distal occlusion alarm pressure is approx. 5 to 7 psi
Air-in-line Detection	Air bubbles approximately 50 microliters or larger
Flow Rate Range	1-999 mL/hr in 1 mL increments, for both primary and secondary
Volume Range	1-9999 mL for both primary and secondary
Keep Vein Open (KVO) Rate	5 mL/hr or programmed rate, whichever is less
Nurse Call	Optional: an installation kit is required
Battery Life	5 hours on fully charged batteries, at 125 mL/hr
Battery Recharge	16 hours to recharge to 80% of capacity
AC Power Requirements	110/120V, 60 Hz
Power Cord	2.4 m (8 ft) long, with Hospital Grade plug
Fuse	0.5 A, 250V, SB, 6.35 mm (1/4 in) x 31.8 mm (1-1/4 in)
Leakage Current	Less than 50 microamps (using UL specified test methods)
Weight	6.4 kg (14 lbs)
Dimensions	24 cm W x 16 cm D x 27 cm H (9-1/2 in W x 6 in D x 11 in H)

Physical Description

Refer to figures 1, 2, and 3 for the location of the following items.

Item	Function
1. ON-OFF/CHARGE Key	Turns the pump on and off. The pump's internal battery charger remains on regardless of the ON-OFF/CHARGE key as long as the pump is plugged into a 115 VAC power source.
2. Message Display	Shows all alarm and alert messages.
3. Main Display	Shows rate, volume to be infused (VTBI), and total volume infused for primary and secondary infusion programs.
4. PRI RATE Key	Enters the infusion rate for the primary solution.
5. PRI VTBI Key	Enters the VTBI for the primary solution.
6. PRI START Key	Starts the delivery of the primary solution.
7. Numerical Keyboard	The numerical values for Rate and VTBI are entered with these keys. The CLR key clears any RATE or VTBI currently being entered.
8. STOP Key	Stops pumping until further instructions are given. An alert will sound if the pump is stopped for more than two minutes.
9. SILENCE Key	Temporarily silences an audible alarm or alert for two minutes. All visual alarm or alert information remains displayed.
10. SEC RATE Key	Enters the infusion rate for the secondary solution.
11. SEC VTBI Key	Enters the VTBI for the secondary solution.
12. SEC START Key	Starts the delivery of the secondary solution.
13. ALARM LED	Red LED that blinks on and off during an alarm, accompanied by a visual message display and a rapid three-tone sound. An alarm indicates that the pump requires immediate attention.
14. PUMPING LED	Green LED which is constantly lit during pumping.
15. ALERT LED	Yellow LED which is constantly lit during an alert, accompanied by a visual message display and a single tone every eight seconds. An alert indicates that the pump requires some routine attention.
16. TOT VOL/STATUS Key	When pressed, the total volume infused is displayed for three seconds, and then all rate and volume data for each pumping program is displayed for three seconds.
17. CLEAR TOT VOL Key	Resets the volume infused to zero when the pump is stopped.
18. BACK LIGHT Key	Backlights the main and message displays when pressed. Pressing the key again turns the backlighting off. If the pump is operating on battery power, the backlighting remains on for 60 seconds each time the BACKLIGHT key is pressed.
19. CHARGING LED	Green LED which is constantly lit while the pump is plugged in and the battery is charging.
20. Door Latch	Opens and closes the pump door.
21. Upstream Occlusion Sensor	Detects a complete tubing restriction upstream of the pump.
22. Pumping Mechanism	Linear peristaltic pumping mechanism.

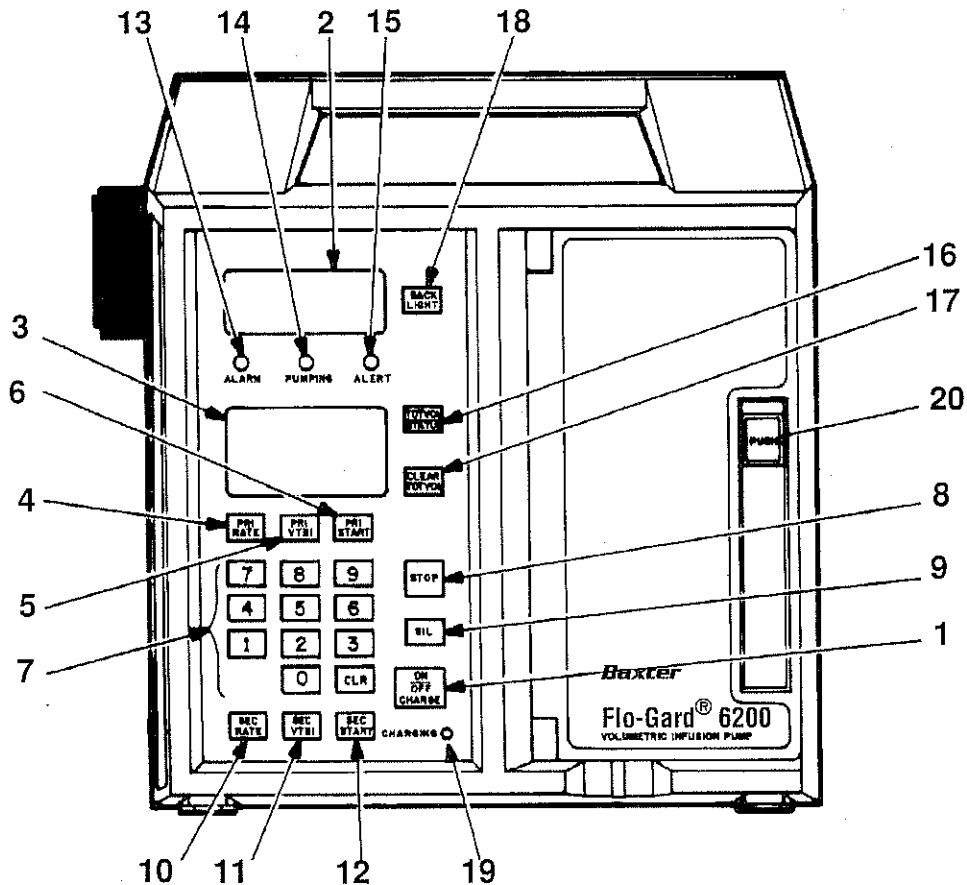

Figure 1. Front View of Pump

- | | |
|---------------------------------|--|
| 23. Downstream Occlusion Sensor | Detects tubing restrictions downstream of the pump. |
| 24. Tube Loading Diagram | Shows the correct way to load tubing into the pump. |
| 25. Safety Clamp | Prevents accidental fluid flow when the pump door is opened. |
| 26. Air Sensor | Detects air bubbles in the tubing. |
| 27. Power Cord Clip | Stores power cord during battery operation and pump storage. |
| 28. PANEL LOCK Switch | Disables front panel controls, except BACKLIGHT and TOT VOL/STATUS, when pressed. |
| 29. FUSE | Fuse compartment |
| 30. VOLUME Knob | Adjusts sound level of audible alarm and alert tones. The tones cannot be turned completely off. |
| 31. Power Cord | Removable only by qualified personnel for easy replacement. |
| 32. Accessory Port | Allows addition of future accessories. |
| 33. Audio Speaker | For generation of audible alarm and alert tones. |
| 34. Nurse Call Port | Allows addition of an optional nurse call jack. |
| 35. Battery Compartment | Allows easy access to the battery. |
| 36. IV Pole Clamp | Secures the pump to the IV pole. |

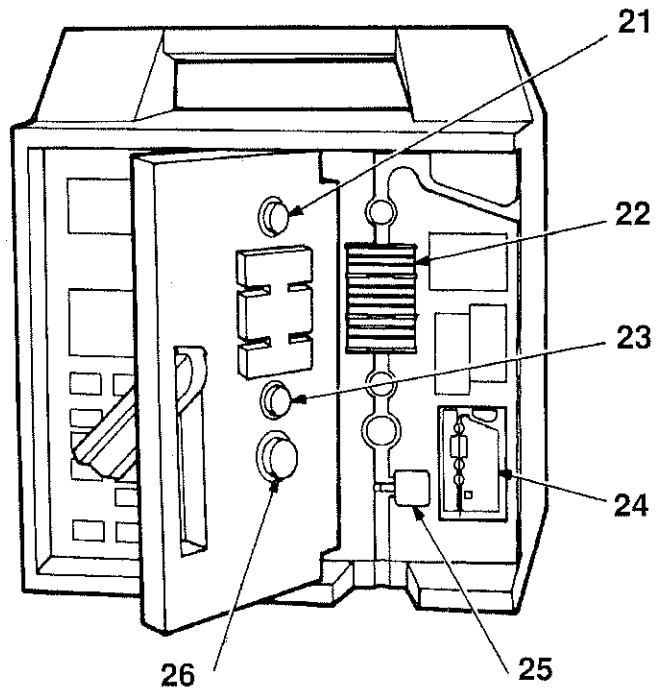

Figure 2. Pump with Door Open

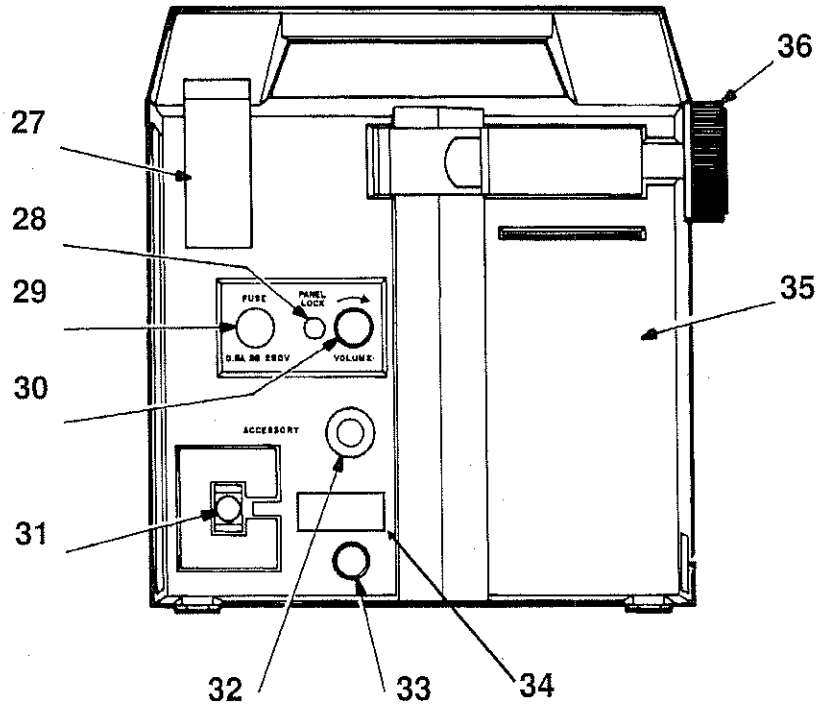

Figure 3. Rear View of Pump

Operating Instructions

Safety Precautions

- DANGER - Possible explosion hazard if used in the presence of flammable anesthetics.
- Operate pump from 115 V, 60 Hz, hospital grade earth-grounded outlet only. Leave the pump plugged in when not in use to maintain the battery charge.
- As with any infusion device, always replace fluid containers before air is permitted to enter the set. If air enters the set, or if the pump detects air, purge all air from set.
- Do not store pump with the ON-OFF/CHARGE key ON. The battery may discharge completely.
- Always close the administration set control clamp before opening pump door and removing set.
- Ensure that tubing is loaded straight through the pump mechanism tubing guides and safety clamp before closing the pump door. If resistance is felt when closing the door, check for misloaded tubing.
- Use only with standard Baxter soft tubing administration sets that contain an "s" as the last character of the code number (for example: 2C5417s).
- When infusing fluid through a central venous catheter, Baxter recommends sets with a Luer lock adapter be used.
- If using a filter set, use only filters which state specifically in the Instructions that they may be used with pumps. Read and follow instructions of the filter to be used.
- When a secondary infusion is programmed, use only Continu-Flo[®] sets as the primary line with a compatible secondary set for the secondary line.
- As with any infusion device, always verify programmed information prior to starting the device.

Instructions For Use

1. Read and understand this manual before using pump.
2. Plug pump into a 115 V, 60Hz grounded outlet, unless battery power is required.
3. Prepare fluid container and attach administration set according to the directions accompanying the products. Expel all air from set.
4. Close set control clamp.
5. Raise pump door handle to horizontal position and pull door open.
6. Push safety clamp to open position.
7. Thread tubing through guide channel from top to bottom as shown in fig. 4.
8. Close pump door.
9. Open set control clamp completely. Verify that no drops are falling in drip chamber. If flow is observed, recheck tube loading and make sure the proper set is being used. If flow is again observed, do not use the pump. Have it inspected by service personnel.
10. Attach set to venipuncture or other device.
11. Press ON-OFF/CHARGE key. All displays illuminate momentarily as shown in figure 5. The audible alarm sounds and if pump is plugged in, the CHARGING LED lights.

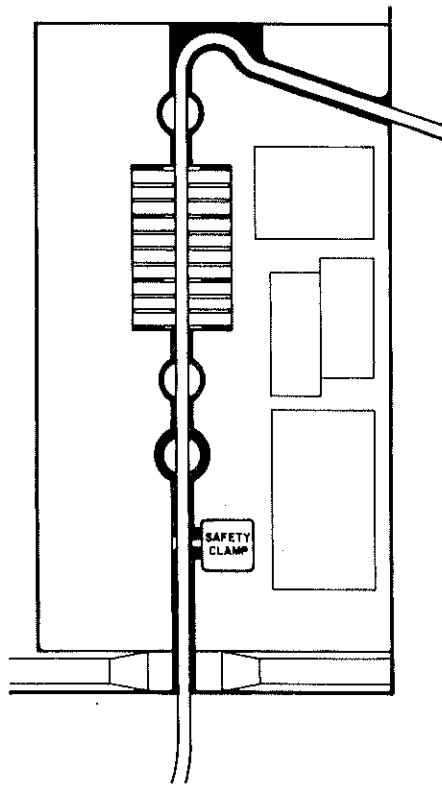

Figure 4. Tube Loading Diagram

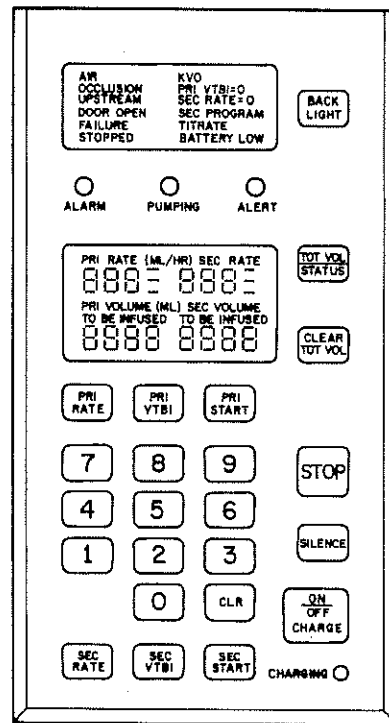

Figure 5. Self-Test Displays

12. Set audible alarm knob on the rear of the pump to the desired level.
13. Set primary flow rate as follows:
 - a. Press RATE key.
 - b. Enter desired flow rate (in mL/hr) on keyboard. The pump will not accept a zero as the first digit entered. To correct a mistake, press PRI RATE again and re-enter correct rate.
14. Set primary volume to be infused as follows:
 - a. Press PRI VTBI.
 - b. Enter desired VTBI (in mL) on keyboard. Set VTBI equal to the amount of fluid in the container or less if desired. To correct a mistake, press PRI VTBI again and re-enter the correct VTBI.
15. If desired, reset the volume infused to zero by pressing CLEAR TOT VOL.
16. Press PRI START key. The green PUMPING LED lights and a moving bar appears next to the flow rate setting. Confirm flow by checking for drops in the administration set drip chamber.
17. To read total volume infused and/or review infusion settings, press TOT VOL/STATUS key. TOTAL VOLUME INFUSED is displayed first, followed by RATE and VTBI.
18. To halt infusion, press STOP key. The PUMPING LED goes out and STOPPED appears in the message display. If pump is not restarted in two minutes, an audible alert sounds.

19. When the selected volume has been delivered, the pump sounds an alert tone and switches to a KVO (Keep Vein Open) rate of 5 mL/hr or the current rate setting, whichever is lower.
Remove set from pump as follows:
 - a. Press STOP key.
 - b. Close set clamp.
 - c. Open pump door.
 - d. Press SAFETY clamp button.
 - e. Check that no fluid is flowing in set, then remove set from pump.

Starting a Secondary Program

1. Prepare secondary fluid container and administration set according to the instructions accompanying the products. Expel all air from the secondary set. To perform automatic piggybacking, a Baxter set labeled Continu-Flo[®] should be used.
2. Close secondary set control clamp.
3. Set secondary flow rate as follows:
 - a. Press SEC RATE key. The right-hand side of the main display now shows secondary infusion data.
 - b. Enter desired flow rate (in mL/hr) for secondary solution. To correct a mistake, press SEC RATE again and re-enter the correct value.
4. Set secondary volume to be infused as follows:
 - a. Press SEC VTBI key.
 - b. Enter the desired fluid amount (in mL) on the keyboard. Set VTBI equal to the volume of fluid in the container. To correct a mistake, press SEC VTBI again and re-enter the correct value.
5. Lower primary container with the hanger accompanying the Baxter secondary set.
6. Open secondary set control clamp.
7. Press SEC START to begin infusion. Drops begin falling in the secondary set drip chamber. When the VTBI of the secondary program reaches zero, the pump reverts to the primary program.

Changing Flow Rates (Titrating) While Pump Is Running

To change the primary flow rate, follow the procedure given below.

1. Press PRI RATE key while pump is running. TITRATE appears in the message display and an alert tone sounds periodically.
2. Enter the new flow rate on the keyboard.
3. Press PRI START. The pump begins delivering fluid at the new rate, the alert tone stops, and the TITRATE message disappears.
4. To change secondary flow rate, follow the above procedure using the SEC RATE and SEC START keys instead of the PRI RATE and PRI START keys.

Locking The Control Panel

The pump control panel can be locked during pumping to prevent tampering. It can be unlocked at any time. The TOT VOL STATUS and BACK LIGHT keys are not affected by the lock-out. This allows routine infusion data checks while the controls are still locked.

To lock the panel: While pump is running, press the PANEL LOCK switch on the rear of pump. The message Loc appears in the main display.

To unlock the panel: Press PANEL LOCK again. The Loc message disappears. If the pump is stopped due to an infusion alarm or an opened door, the panel must be unlocked to restart the infusion.

Battery Powered Operation

The pump can operate on internal battery power for up to five hours at 125 mL/hr. The pump automatically switches to battery operation when the AC power is interrupted or the pump is unplugged. When operating on battery power, BATTERY appears in the message display. The battery automatically recharges whenever the pump is plugged in. It is recommended that the pump be plugged into an AC outlet during storage to maintain batteries at full charge.

Alerts And Alarms

The following chart describes the pump's alarm alert messages along with the cause of each.

Alert Message	Flow Status	Alert Condition
STOPPED	No flow	Pump has been in STOPPED mode for two minutes.
KVO PRI VTBI =0	KVO	Primary VTBI has been delivered. The pump has switched to a KVO rate of 5 mL/hr or programmed rate, whichever is less.
TITRATE	No change until procedure is complete	Flow rate is being changed while pump is running. Pump will remain in TITRATE alert condition until START key is pressed.
PRI RATE =0	No flow	A primary flow rate of zero has been entered. The pump will remain in this alert condition until a non-zero primary flow rate is entered.
BATTERY	No change	Pump is operating on internal battery power.
BATTERY LOW with intermittent alert tone	No change	Battery needs recharging. Pump will stop operating in approximately fifteen minutes unless it is plugged into an AC outlet.
SEC PROGRAM	No Change	Secondary program data is being programmed while pump is running. Pump will remain in SEC PROGRAM alert condition until SEC START key is pressed.
SEC RATE=0	No flow	A secondary flow rate of zero has been entered. The pump will remain in this alert condition until a non-zero secondary flow rate is entered.
SEC VTBI=0	No flow	A secondary VTBI of zero has been entered. The pump will remain in this alert condition until a non-zero secondary VTBI is entered.
Alarm message	Flow status	Possible Cause
AIR	No flow	a. Air bubble at detector b. Empty fluid container c. No set in pump
OCCLUSION	No flow	Closed distal clamp, stopcock, clogged filter or other blockage downstream of the pump.
OCCLUSION UPSTREAM	No flow	Closed clamp or other blockage upstream of the pump.
DOOR OPEN	No flow	Pump door not fully closed.
BATTERY LOW with rapid three-beep alarm tone		Battery power has been exhausted. Plug pump into AC outlet to restore operation and recharge battery.
FAILURE with code number		Press ON-OFF/CHARGE key twice to reset. If FAILURE does not clear, record the error code number, remove pump from use and have it serviced.

Cleaning and Maintenance

The exterior of the pump may be cleaned with a soft cloth, sparingly dampened with any of the cleaners listed below. Follow manufacturers' dilution instructions for concentrated cleaners.

Clean pumps that have been used in an isolation area with an agent from the list below that cleans and disinfects.

If spillage into the pumping mechanism occurs, clean the mechanism immediately by wiping with a soft cloth dampened with any of the cleaners listed below.

List of Cleaners

Cleaner	Manufacturer
LpH, Septisol	Vestal Labs
Cidex 7	Surgikos
Super Edisonite	Edison Chemical Co.
Clinidine	Clinipad Co.
Betadine	Purdue Frederick
A solution of 10% bleach and water	
Soapy water	
Isopropyl alcohol up to 95%	

Do not clean or disinfect internal parts by autoclave, or sterilize the pump with ethylene oxide gas. Doing so may damage the pump and void the warranty.

Do not use the following chemicals on the pump. They will damage the front panel. Acetone, ammonia, benzene, hydroxytoluene, methylene chloride, n-alkyl dimethyl ethybenzyl ammonium chloride, and ozone.

Warranty And Service Information

Warranty

Baxter Healthcare Corporation warrants that the equipment shall be free from defects in material and workmanship when delivered to the original purchaser. Baxter Healthcare Corporation's sole obligation shall be limited to repair or replacement, at Baxter's option and expense, of the defective part or unit for a period of one year following the date of initial delivery. Warranty for the replaceable battery pack is limited to a period of six months under normal use and service.

THERE ARE NO OTHER WARRANTIES INCLUDING ANY IMPLIED WARRANTY AND ANY WARRANTY OF MERCHANTABILITY OR FITNESS FOR A PARTICULAR PURPOSE WHICH EXTEND BEYOND THE DESCRIPTION OF THE PRODUCT AND THOSE EXPRESSLY SET FORTH IN ITS LABELING. UNLESS USED ACCORDING TO THE DIRECTIONS ACCOMPANYING THE PRODUCT, ALL WARRANTIES ARE SPECIFICALLY EXCLUDED. In no event shall Baxter Healthcare Corporation be responsible for incidental, consequential or exemplary damages. Modification, alteration, recalibration or abuse, and service by other than a Baxter Healthcare Corporation authorized representative may void the warranty.

Service Information

While under Baxter Healthcare Corporation Warranty, Service Agreement (optional), or lease agreement, the instrument must not be opened by unauthorized personnel.

Contact Baxter Healthcare Corporation Customer Service Division for service and repair information for all instruments. In USA, call (800) THE-PUMP.

Shipping costs for all units returned to Baxter Healthcare Corporation shall be paid by the customer. The unit must be packed in its original container or in another Baxter approved container that will provide adequate protection during shipment. To ensure prompt return, a Baxter Product Service representative must be notified before shipping any unit for repair. When calling Baxter Product Service, please be prepared to provide code number and serial number of the unit. A service request number will be issued and should accompany all communications. A brief written description of the problem should be attached to the instrument when it is returned for service.

Baxter Healthcare Corporation will not be responsible for unauthorized returns or for units damaged in shipment due to improper packing.