

Register your instrument!
www.eppendorf.com/myeppendorf



epMotion[®] 5070

Hardware manual

Copyright© 2021 Eppendorf AG, Germany. All rights reserved, including graphics and images. No part of this publication may be reproduced without the prior permission of the copyright owner.

Qiagen® and Rotor-Disc® are registered trademarks of Qiagen GmbH, Germany.

Magnum FLX® is a registered trademark of Alpaqua Engineering, LLC, USA. Used by permission.

Illumina® is a registered trademark of Illumina, Inc., U.S

ep*Motion*®, Eppendorf Tubes ®, and epT.I.P.S.® are registered trademarks of Eppendorf AG, Germany.

Eppendorf® and the Eppendorf Brand Design are registered trademarks of Eppendorf AG, Germany.

Registered trademarks and protected trademarks are not marked in all cases with ® or ™ in this manual.

Magnum FLX magnet adapter 96 well plates U.S. Pat. No. 6,755,384 and 9,663,780

ep*Motion* optical sensor U.S. Pat. No. 6,819,437

U.S. Design Patents are listed on www.eppendorf.com/ip.

The software of the device (firmware) contains open source software. License information is available on request from Eppendorf AG, Germany.

Table of contents

1	Operating instructions	9
1.1	Using this manual	9
1.2	Danger symbols and danger levels	9
1.2.1	Danger symbols	9
1.2.2	Danger levels	9
1.3	Symbols used	10
1.4	Abbreviations used	10
1.5	Glossary	11
1.6	Revision history	15
2	Safety	17
2.1	Intended use	17
2.1.1	Intended use epMotion 5070	17
2.1.2	Intended use epMotion 5070f	17
2.2	User profile	18
2.3	Information on product liability	18
2.4	Warnings for intended use	18
2.5	Warning symbols and safety equipment on the device	21
3	Product description	23
3.1	Product overview	23
3.1.1	epMotion 5070	23
3.1.2	epMotion 5070f	24
3.1.3	Interfaces	25
3.2	EasyCon tablet	26
3.3	MultiCon PC	27
3.4	Delivery package	28
3.4.1	epMotion 5070	28
3.4.2	epMotion 5070f	28
3.4.3	Accessories for all versions of the epMotion	28
3.4.4	Accessories for epMotion with epBlue ID	29
3.4.5	Accessories for epMotion with epBlue GxP	29
3.5	Features	30
3.5.1	Principle of operation	30
3.5.2	Cleanbench	30
4	Installation	31
4.1	Selecting the location	31
4.2	Installing the device	31
5	Hardware	33
5.1	Worktable for epMotion 5070 and epMotion 5070f	33
5.2	Optical sensor	34
5.3	Tools	36
5.3.1	Dispensing tools	36
5.4	Barcode reader	37

6	Dispensing liquids	39
6.1	Operation of the dispensing tools	39
6.1.1	Dispensing modes	39
6.1.2	Volume aspiration in the Multidispense dispensing mode	42
6.1.3	Calculating the volume aspiration in the Multidispense dispensing mode	43
6.1.4	Mixing liquids	43
6.2	Bottom tolerance	44
6.3	Liquid aspiration	44
6.3.1	Liquid aspiration with a constant immersion depth (Default)	45
6.3.2	Liquid aspiration from the vessel base (Aspirate from bottom)	47
6.3.3	Liquid aspiration from a defined position	49
6.4	Transporting the liquid	53
6.5	Liquid dispensing	54
6.5.1	Liquid dispensing in a free jet (Default)	54
6.5.2	Liquid dispensing with contact to the surface (Default)	55
6.5.3	Liquid dispensing at the height of the edge of the vessel (Dispense from top)	56
6.5.4	Liquid dispensing from a defined position	57
7	Labware – vessels, plates and pipette tips	61
7.1	Tubes	61
7.2	Plates	62
7.2.1	PCR plates	62
7.2.2	Deepwell plates	63
7.2.3	Microplates	64
7.2.4	Tube plates	64
7.3	Reservoirs	65
7.3.1	Reservoir 10 mL	65
7.3.2	Reservoir 30 mL	65
7.3.3	Reservoir 100 mL	66
7.3.4	Reservoir 400 mL	66
7.4	epT.I.P.S. Motion	67
7.4.1	epT.I.P.S. Motion Racks	68
7.4.2	epT.I.P.S. Motion SafeRacks	69
7.4.3	epT.I.P.S. Motion reloads	70
7.4.4	TipHolder for epT.I.P.S. Motion reloads	71
8	Labware accessories	73
8.1	Tip Tool	73
8.1.1	Picking up the pipette tips	74
8.1.2	Ejecting the pipette tips	74

8.2	Racks	75
8.2.1	Rack for 24 vessels	75
8.2.2	Rack for 96 conical vessels	75
8.2.3	Rack 0.5/1.5/2.0 mL	76
8.2.4	Rack LC	76
8.2.5	Rack for ILMN tubes	77
8.2.6	Thermorack 0.5/1.5/2.0 mL	77
8.2.7	Thermorack Rotor/Tubes	78
8.2.8	ReservoirRack	79
8.2.9	ReservoirRack modules	80
8.3	Adapter	87
8.3.1	Height adapter	87
8.3.2	Thermoadapter for PCR plates and deepwell plates	88
8.3.3	Thermoadapter LC Samples	88
8.3.4	Thermoadapter Microplate 96/V/U	89
8.3.5	Thermoadapter Frosty	89
8.3.6	Magnum FLX magnetic adapter 96-well plates	90
8.4	Thermoblock	92
8.4.1	Thermoblock PCR 96	92
8.4.2	Thermoblock PCR 96 OC	93
8.4.3	Thermoblock PCR 384	94
8.4.4	Thermoblock DWP 2000	94
8.4.5	Comparing thermoblocks and thermoadapters	95
8.5	Waste container	96
8.5.1	Waste box	96
8.5.2	Waste bag holder	97
8.5.3	LiquidWasteTub	98
8.5.4	Waste bag	99
9	Operation	101
9.1	First steps	101
9.1.1	Switching on the epMotion	101
9.1.2	Operation of the epMotion	101
9.1.3	Backing up data	102
9.1.4	Working with epMotion	102
9.2	Placing tools and labware on the worktable	103
9.2.1	Displaying the epBlue worktable	103
9.2.2	Placing dispensing tools on the worktable	103
9.2.3	Placing the epT.I.P.S. Motion on the worktable	104
9.2.4	Placing the waste container on the worktable	104
9.2.5	Placing additional labware on the worktable	105
9.3	Executing an application	107
9.3.1	Performing a test run	107
9.3.2	Performing an application run	108
9.3.3	Controlling the application run	108
9.4	Completing your work	110
9.4.1	Cleaning up the worktable	110
9.4.2	Switching off epMotion	110

10	Maintenance	111
10.1	Decontamination and cleaning	111
10.1.1	Cleaning	111
10.1.2	Decontamination methods and decontamination agents	112
10.1.3	Performing a wipe decontamination	113
10.1.4	Performing a spray decontamination	114
10.1.5	Autoclaving	114
10.1.6	Decontaminating the Magnum FLX magnetic adapter 96-well plates using 70 % ethanol solution	115
10.1.7	Decontaminating the Magnum FLX magnetic adapter 96-well plates using an ortho-phthalaldehyde-based solution	115
10.2	Shipping the device	116
10.3	Servicing the device	116
10.4	Fuses	117
10.5	Checking the dispensing volume	117
10.6	Servicing the dispensing tools	118
10.6.1	Replacing the sealing rings on the dispensing tool	118
10.7	Customer service functions	119
11	Troubleshooting	121
11.1	Error search	121
11.2	General errors	122
11.2.1	Optical sensor error	122
11.2.2	Dispensing error	122
12	Transport, storage and disposal	125
12.1	Transport	125
12.2	Storage	125
12.3	Disposal	125
13	Technical data	127
13.1	Power supply	127
13.2	Ambient conditions	127
13.3	Weight/dimensions	127
13.4	Noise level	127
13.5	Interfaces	128
13.6	MultiCon PC	128
13.7	EasyCon tablet	128
13.8	Additional specifications	129
13.8.1	Optical sensor	129
13.8.2	Carrier	129
13.9	Enhancements	129
13.9.1	Barcode reader	129
13.9.2	Tip Tool	129
13.10	Dispensing tool errors	130
13.10.1	Pipetting	130
13.10.2	Test conditions	131

14	Ordering information	133
14.1	Tools	133
14.2	epT.I.P.S. Motion	133
14.2.1	epT.I.P.S. Motion racks	133
14.2.2	epT.I.P.S. Motion SafeRacks	134
14.2.3	epT.I.P.S. Motion Reloads	135
14.2.4	Adapter	135
14.2.5	Accessories	136
14.3	Plates	136
14.4	Reservoirs	137
14.5	Racks	137
14.5.1	Racks for individual tubes	137
14.5.2	Thermoracks	138
14.5.3	ReservoirRacks	139
14.5.4	ReservoirRack modules	139
14.6	Adapter	140
14.6.1	Height adapter	140
14.6.2	Thermoadapter	140
14.6.3	Magnetic adapter	140
14.7	Thermoblocks	140
14.8	Accessories	141
14.9	Modification kits and enhancements	142
	Index	143
	Certificates	147

1 Operating instructions

1.1 Using this manual

The operating manual of your epMotion consists of a manual for the hardware and a manual for the software. For some optional software modules, separate manuals are available.

The operating manual is part of the product.









The current version of the operating manual can be found on our website at www.eppendorf.com.

- ▶ Read the complete operating manual before using the device.
- ▶ Store the operating manual at an easily accessible location.
- ▶ The device may only be transferred with the operating manual.
- ▶ If the operating manual is lost, replace it immediately. Please contact Eppendorf AG.

1.2 Danger symbols and danger levels

1.2.1 Danger symbols

The safety instructions in this manual have the following danger symbols and danger levels:

	Biohazard		Explosive substances
	Electric shock		Heavy load
	Cuts		Hot surfaces
	Hazard point		Material damage

1.2.2 Danger levels

DANGER	<i>Will</i> lead to severe injuries or death.
WARNING	<i>May</i> lead to severe injuries or death.
CAUTION	<i>May</i> lead to light to moderate injuries.
NOTICE	<i>May</i> lead to material damage.

1.3 Symbols used

Depiction	Meaning
1. 2.	Actions in the specified order
▶	Actions without a specified order
•	List
<i>Text</i>	Display or software texts
i	Additional information

1.4 Abbreviations used

BCR

Barcode reader

CRM

Customer Relationship Management

CSV

Comma Separated Value

DNA

Deoxyribonucleic acid

DWP

Deepwell plate

epT.I.P.S.

Eppendorf Totally Integrated Pipetting System

LH

Liquid Handling

LIMS

Laboratory Information Management System

MTP

Microplate

NGS

Next Generation Sequencing

PCR

Polymerase Chain Reaction

PDF

Portable Document Format

USB

Universal Serial Bus

1.5 Glossary

A

Application

Program for a particular application. An application includes the procedure and the equipping of the worktable.

B

Barcode reader

Device for scanning an ID.

Bottom tolerance

The bottom tolerance is the distance between the vessel base and the lower end of the pipette tip. The default setting is 1 mm. For the 30 mL reservoir, the default setting is 2.5 mm. You can change the bottom tolerance.

C

Cleanbench

A Class 2 safety cabinet for personal safety and product protection. A laminar air flow prevents germs from entering the cabinet from the ambient environment. The air flow also prevents aerosols contaminated with microorganisms from escaping the safety cabinet.

Contact dispensing

The pipette tip places a drop on a surface. The contact with the surface causes the drop to separate from the pipette tip. The pipette tip places a drop on a liquid level (wet contact dispensing) or on the surface of a vessel (dry contact dispensing).

D

Destination labware

Rack or plate with destination positions.

Destination position

Position in the labware that is only used as the destination of liquid transfers.

Dispensing tool

A tool that aspirates and dispenses liquid. Single-channel and eight-channel dispensing tools are available for various volume ranges.

Operating instructions

epMotion® 5070
English (EN)

Dry contact dispensing

The pipette tip places a drop on the surface of a vessel. The contact with the surface of the vessel causes the drop to separate from the pipette tip.

E**EasyCon Tablet**

Eppendorf EasyCon™ tablet. With the tablet, the epBlue software is used to control your epMotion.

epBlue

Software for creating and administrating applications and labware. The epBlue software is used for controlling the epMotion.

Eppendorf Quality

Eppendorf Quality is an Eppendorf AG purity grade for consumables. Eppendorf Quality meets the requirements for standard products, e.g., precision, accuracy, wetting behavior and leak tightness.

epT.I.P.S. Motion

Pipette tips of the epMotion. epT.I.P.S.® Motion are available with and without filter. The abbreviation stands for Eppendorf Totally Integrated Pipetting System.

F**Filling volume**

Maximum volume of a labware. The filling volume is greater than the working volume. The epMotion removes liquid from the labware up to the filling volume.

Free jet dispensing

The pipette tip dispenses liquid while it is in the air. The pipette tip has no contact with a surface.

H**Height adapter**

Adapter for low labware. The height differences between the labware are offset to decrease the tool holder paths and therefore decrease the cycle time of the application.

I**Intermediate labware**

Rack or plate with intermediate positions.

Intermediate position

Position in a labware that is the source and destination of liquid transfers.

L**Labware**

Racks, plates, tips, etc. which are placed on the worktable.

Location

Area on the worktable where the labware is placed.

M

MultiCon PC

Computer with a touch screen. With the computer you use the epBlue software to control your epMotion.

P

PCR clean

PCR clean is an Eppendorf AG purity grade for consumables. PCR clean meets the requirements for standard products, e.g., precision, accuracy, wetting behavior, leak tightness. PCR clean also meets the requirements with regard to absence of human DNA, DNase, RNase and PCR inhibitors. Consumables with the purity grade PCR clean are inspected and certified by an external laboratory. Certificates are available on our webpage www.eppendorf.com.

Procedure

Sequence of commands that are executed one after the other. Part of an application.

R

Rack

Mount for tubes or pipette tips.

Random error

Imprecision. A measure for the scattering (standard deviation) of the measured values around the average value.

Remaining volume

Volume which the pipette tip is unable to aspirate from a tube. Caused by the bottom tolerance of the labware, the immersion depth of the pipette tip into the liquid and the tube geometry. The remaining volume results for pipetting under standard conditions, as the pipette tip has a minimum immersion depth in the liquid and a minimum distance to the vessel base (bottom tolerance). Under standard conditions, the remaining volume has a filling height of 1.7 mm (bottom tolerance of 1 mm + minimum depth of immersion of 0.7 mm).

Reservoir

Reservoirs are used for preparing reagents. Reservoirs are hung in a ReservoirRack or placed directly on the worktable.

S

SafeRack

Rack with ep.T.I.P.S. Motion pipette tips. The SafeRack features a partition that prevents the contamination of adjacent tips. Use the SafeRacks if you would like to use tips several times.

Source labware

Rack or plate with source positions.

Operating instructions

epMotion® 5070
English (EN)

Source position

Position in a labware that is only used as the source for liquid transfers.

Sterile

Sterile is an Eppendorf AG purity grade for consumables. Sterile meets the requirements for standard products, e.g., precision, accuracy, wetting behavior, leak tightness. Sterile also meets the requirements with regard to sterility and freedom from pyrogens.

Systematic error

Inaccuracy. Deviation of the average value of the dispensed volumes from the selected volume.

T

Thermoadapter

Temperature-controlled adapter that is not transported with the gripper. Plates are inserted into the thermoadapter.

Thermoblock

Temperature-controlled adapter that is transported with the gripper. Plates are inserted into the thermoblocks.

There are two types of thermoblocks for epBlue:

- *Thermoblocks*: Thermoblocks and plates are available as separate labware definitions.
- *Thermoblocks with Plates* Thermoblocks and plate are combined in one labware definition. The thermoblock is not available as a separate labware definition.

Thermorack

Temperature-controlled rack for smaller vessels, e.g. Eppendorf Safe-Lock tubes for 0.5 mL, 1.5 mL or 2 mL.

W

Wet contact dispensing

The pipette tip places a drop on the surface of the liquid. Contact with the surface of the liquid causes the drop to separate from the pipette tip.

Working volume

The filling volume minus the volume of the pipette tip that is immersed. epMotion fills the vessels up to the working volume.

Worktable

epMotion work surface on which the labware and tools are placed. In the software, the epMotion worktable is represented as the epBlue worktable.

1.6 Revision history

Revision history of the epMotion 5070 hardware manual, order no. 5070 900.850

Operating manual version	Date	Changes
Version 00	June 2013	<ul style="list-style-type: none"> • Document created
Version 01	August 2015	<ul style="list-style-type: none"> • MultiCon PC and EasyCon tablet can be selected as control device • New labware
Version 02	March 2016	<ul style="list-style-type: none"> • Delivery package revised • New certificate
Version 03	February 2017	<ul style="list-style-type: none"> • New dispensing tools • New labware • New dispensing modes
Version 04	August 2017	<ul style="list-style-type: none"> • Error of measurement for dispensing tools changed.
Version 05	October 2017	<ul style="list-style-type: none"> • Change of layout
Version 06	March 2018	<ul style="list-style-type: none"> • New waste container, waste bag • FLX magnetic adapter, rack for ILMN tubes • Stacking of epT.I.P.S. Motion and plates with lids
Version 07	April 2019	<ul style="list-style-type: none"> • New PCR, NGS and Tips ReservoirRack modules
Version 08	March 2021	<ul style="list-style-type: none"> • Barcode reader amended • TipTool amended • New MultiCon • Spare parts removed and new spare parts added • Technical data changed

2 Safety

2.1 Intended use

2.1.1 Intended use epMotion 5070

The device is intended for use in laboratories for research, development, and industrial and routine work, as well as for training purposes. The areas of application include, but are not limited to the fields of life sciences, biotechnology and chemistry.

The automated liquid handling system epMotion 5070 is designed for monitoring the contamination-free, accurate and correct dispensing and transferring of liquids and for the automatic checking of the combination of liquids.

The autoclavable dispensing tools work in a volume range from 0.2 µL to 1000 µL.

The device complies with the relevant essential requirements of the EU directives and standards listed in the declaration of conformity.

These automated liquid-handling systems are exclusively intended for indoor use and may only be used by skilled specialists who have received adequate training.

2.1.2 Intended use epMotion 5070f

The device is intended for use in laboratories for research, development, and industrial and routine work, as well as for training purposes. The areas of application include, but are not limited to the fields of life sciences, biotechnology and chemistry.

The automated liquid handling system epMotion 5070f is designed for monitoring the contamination-free, accurate and correct dispensing and transferring of liquids and for the automatic checking of the combination of liquids.

The autoclavable dispensing tools work in a volume range from 0.2 µL to 1000 µL.

The epMotion 5070f may only be operated in a Cleanbench.

The device complies with the relevant essential requirements of the EU directives and standards listed in the declaration of conformity.

These automated liquid-handling systems are exclusively intended for indoor use and may only be used by skilled specialists who have received adequate training.

2.2 User profile

This device may only be operated by specialists.

The specialists must have received training on this device. The training must have been conducted by Eppendorf AG or an authorized partner of Eppendorf AG.

The specialists must have read the operating manual of the device carefully. The specialists must have read the operating manuals of all installed software modules carefully.

2.3 Information on product liability

In the following cases, the designated protection of the device may be affected. The liability for any resulting damage or personal injury is then transferred to the owner:

- The device is not used in accordance with the operating manual.
- The device is used outside of its intended use.
- The device is used with accessories or consumables that are not recommended by Eppendorf.
- The device is maintained or repaired by persons not authorized by Eppendorf AG.
- The user makes unauthorized changes to the device.

2.4 Warnings for intended use



DANGER! Risk of explosion.

- ▶ Do not operate the device in areas where work with explosive substances is carried out.
- ▶ Do not use this device to process any explosive or highly reactive substances.
- ▶ Do not use this device to process any substances which could generate an explosive atmosphere.



WARNING! Lethal voltages inside the device.

Touching high-voltage parts can cause an electric shock. Electric shocks cause heart injury and respiratory paralysis.

- ▶ Ensure that the housing is closed and undamaged.
 - ▶ Do not remove the housing.
 - ▶ Ensure that no liquids can penetrate the device.
- Only authorized service staff may open the device.



WARNING! Risk of electric shock due to damage to the device or the mains/power cord.

- ▶ Only switch on the device if the device and the mains/power cord are undamaged.
- ▶ Only operate devices which have been installed or repaired properly.
- ▶ In the event of danger, disconnect the device from the mains/power supply voltage. Disconnect the mains/power plug from the device or the earth/grounded socket. Use the isolating device intended for this purpose (e.g., the emergency switch in the laboratory).



WARNING! Risk due to incorrect voltage supply.

- ▶ Only connect the device to voltage sources which correspond with the electrical requirements on the name plate.
- ▶ Only use earth/grounded sockets with a protective earth (PE) conductor.
- ▶ Only use the mains/power cord supplied.



DANGER! Danger due to high voltage.

- ▶ Always ensure that this device and the mains/power cord supplied are grounded properly before performing the initial setup of the device.



WARNING! Damage to health due to infectious liquids and pathogenic germs.

- ▶ When handling infectious liquids and pathogenic germs, observe the national regulations, the biosafety level of your laboratory, and the manufacturers' Safety Data Sheets and application notes.
- ▶ Wear your personal protective equipment.
- ▶ For comprehensive regulations about handling germs or biological material of risk group II or higher, please refer to the "Laboratory Biosafety Manual" (source: World Health Organization, Laboratory Biosafety Manual, in the currently valid version).



WARNING! Health hazard from skin contact with infectious substances.

- ▶ Wear protective gloves.



WARNING! Danger due to flammable and infectious liquids in the waste container and waste bags.

Pipette tips in the waste container and in waste bags may contain flammable or infectious liquids.

- ▶ Wear your personal protective equipment.
- ▶ Handle the pipette tips and sample material from the waste container and waste bags in accordance with the safety data sheets, safety regulations and laboratory guidelines.
- ▶ Dispose of the pipette tips and sample material from the waste container and waste bags in accordance with the safety data sheets, safety regulations and laboratory guidelines.



WARNING! Risk to health due to contaminated device and accessories.

- ▶ Decontaminate the device and accessories prior to storage or shipping.



CAUTION! Risk of injury due to movement of the carrier.

The carrier may still be moving when the front hood of the epMotion is opened.

- ▶ Wait until the carrier is at standstill before reaching into the device.



CAUTION! Cuts due to broken glass.

A damaged touch screen can cause cuts to the hands.

- ▶ Only work with the touch screen if it is not damaged.



CAUTION! Risk of poor safety due to incorrect accessories and spare parts.

The use of accessories and spare parts other than those recommended by Eppendorf may impair the safety, functioning and precision of the device. Eppendorf cannot be held liable or accept any liability for damage resulting from the use of accessories and spare parts other than those recommended or from improper use.

- ▶ Only use accessories and original spare parts recommended by Eppendorf.



NOTICE! Damage to plastic due to UV radiation.

Plastics become brittle when they are exposed to UV radiation. Minute cracks may form in the front cover.

- ▶ If you irradiate your device regularly with UV light, have the device serviced by the authorized service once a year.



NOTICE! Risk of damage to device due to liquid spills.

- ▶ Switch off the device.
- ▶ Disconnect the mains/power plug.
- ▶ Collect the spilled liquid. Observe the information in the Safety Data Sheet for the liquid.



NOTICE! Change in the size of single-use items through autoclaving.

- ▶ Do not use autoclaved single-use items in automated applications.

2.5 Warning symbols and safety equipment on the device

This section explains the warning symbols on the epMotion and the location of the safety equipment.

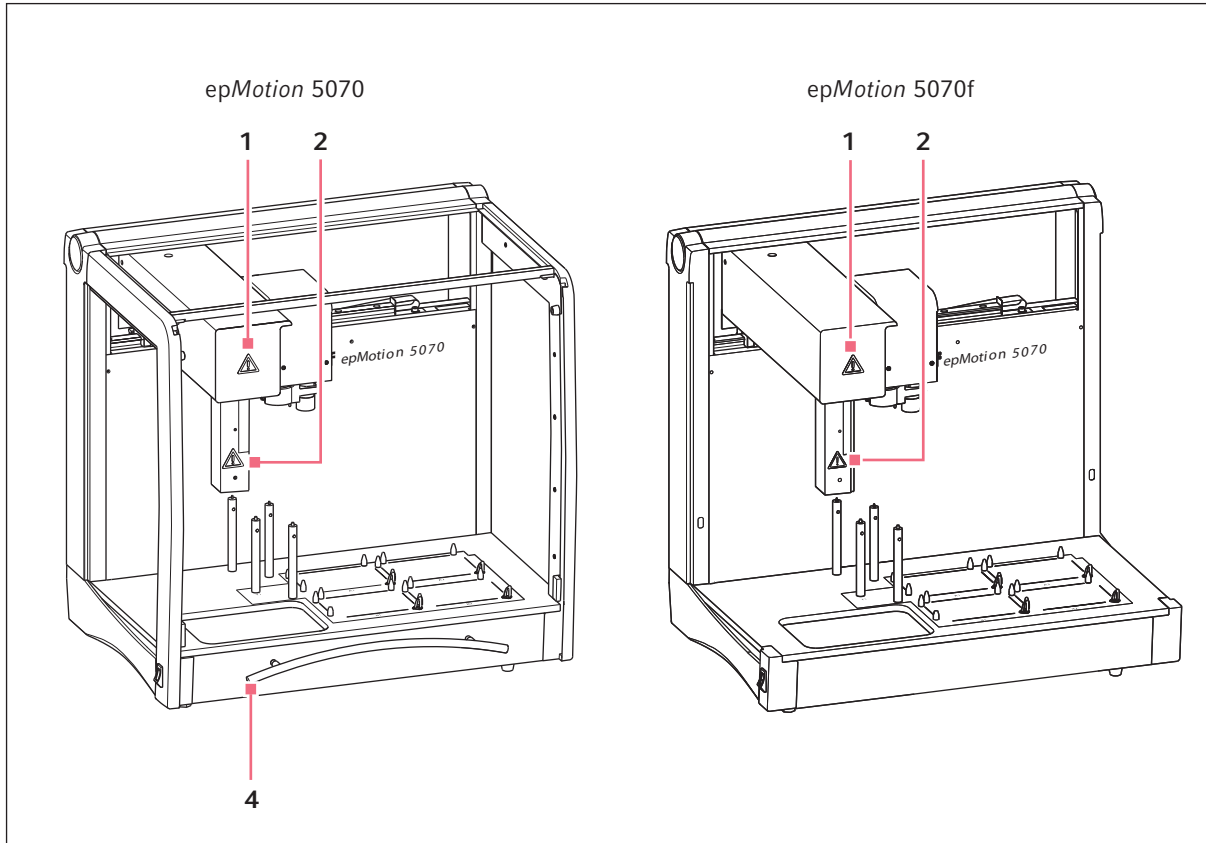



Fig. 2-1: Danger symbols and safety equipment on the epMotion 5070

Tab. 2-1: Warning symbols

1		<p>WARNING Observe the operating manual.</p>
2		<p>WARNING The carrier may continue to move after the front panel has been opened.</p> <p>► Wait until the carrier stops moving before reaching into the device.</p>

Tab. 2-2: Safety equipment

4		<p>The housing or the cleanbench protect the user from contamination and moving parts.</p>
---	--	--

3 Product description

3.1 Product overview

3.1.1 epMotion 5070

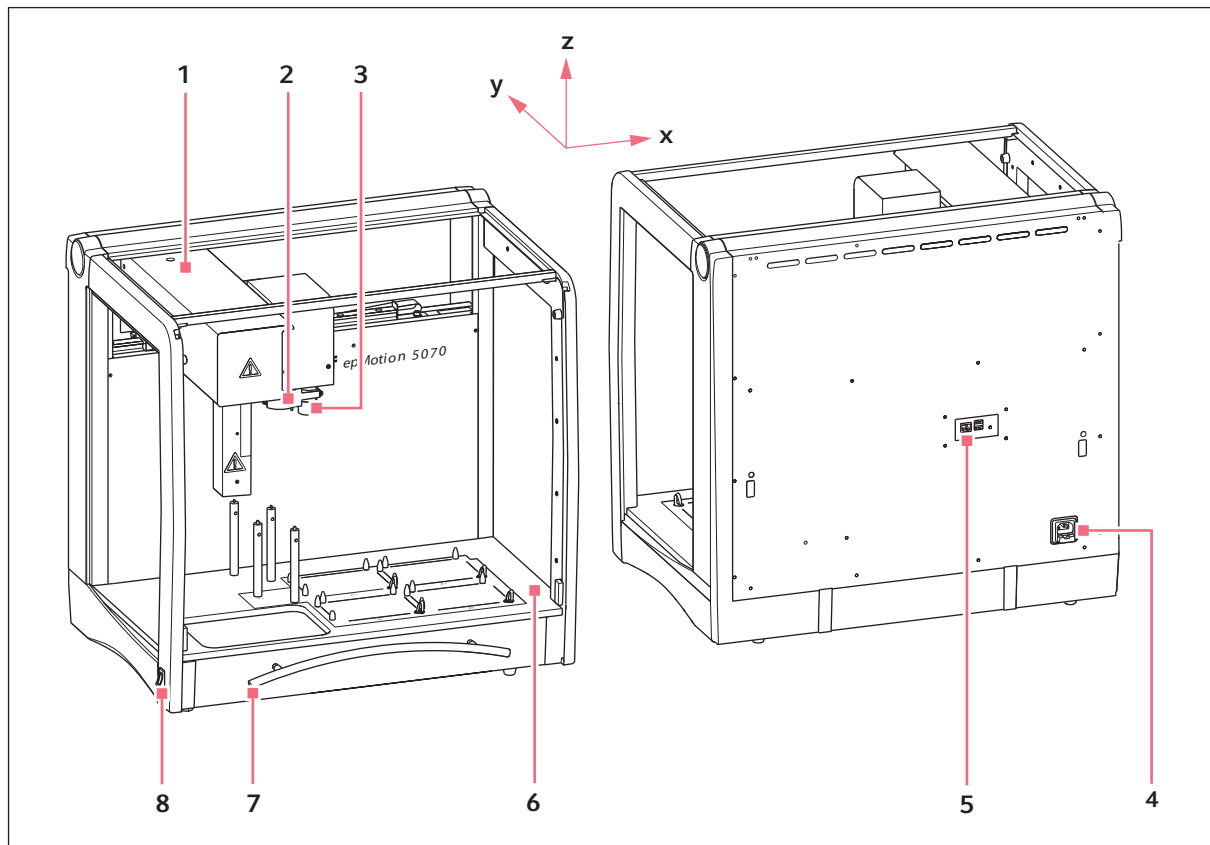

Fig. 3-1: epMotion 5070 overview

- | | |
|--|---|
| 1 Carrier
The carrier moves in X-direction, Y-direction and Z-direction. | 5 Interfaces |
| 2 Tool holder
Holds dispensing tools. | 6 Worktable
Work surface for placing tools and labware. |
| 3 Optical sensor
Detects filling levels, tips, and labware. | 7 Front hood
Safety device for protection from movable parts and contamination. |
| 4 Mains/power connection | 8 Mains/power switch |

3.1.2 epMotion 5070f

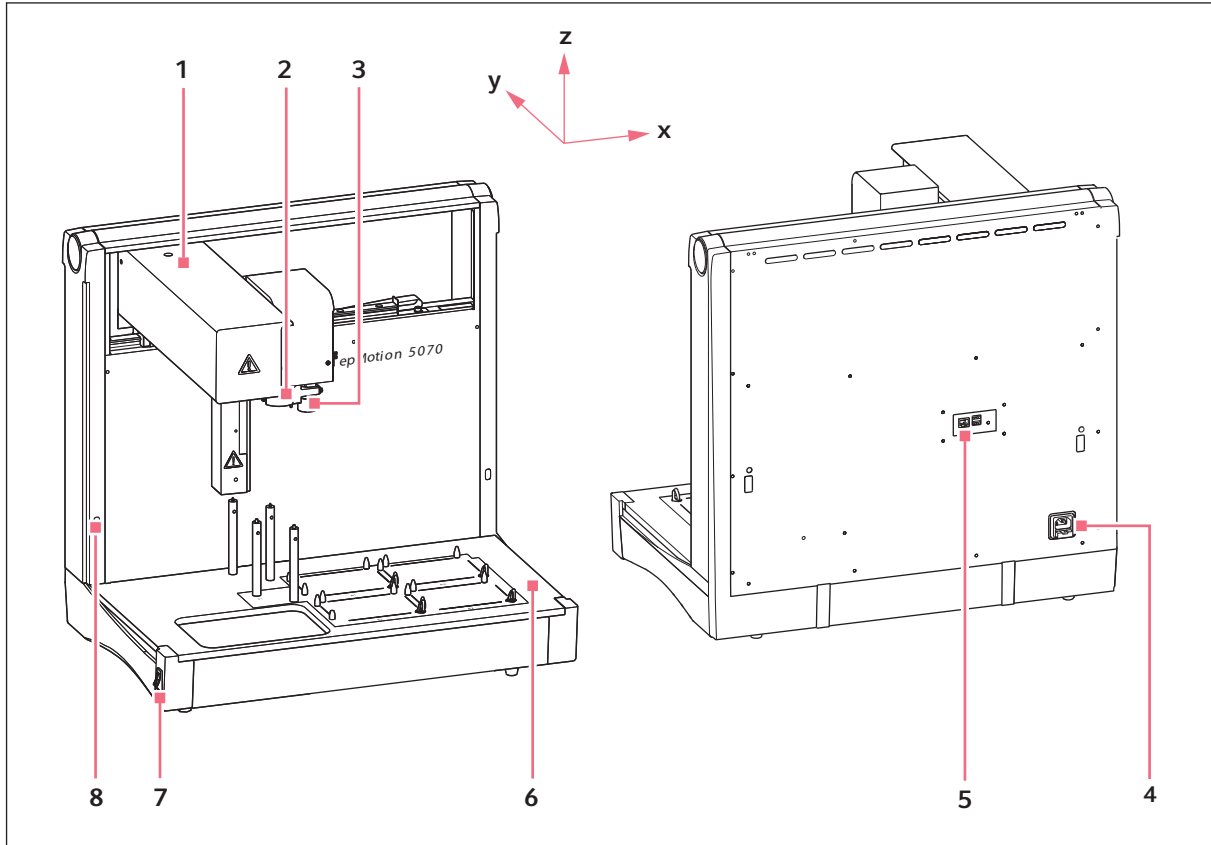

Fig. 3-2: epMotion 5070f overview

1 Carrier

The carrier moves in X-direction, Y-direction and Z-direction.

2 Tool holder

Holds dispensing tools.

3 Optical sensor

Detects filling levels, tips, and labware.

4 Mains/power connection

5 Interfaces

6 Worktable

Work surface for placing tools and labware.

7 Mains/power switch

8 Light barrier

The light reflectors are located on the inside of the front screen of the Cleanbench.

3.1.3 Interfaces

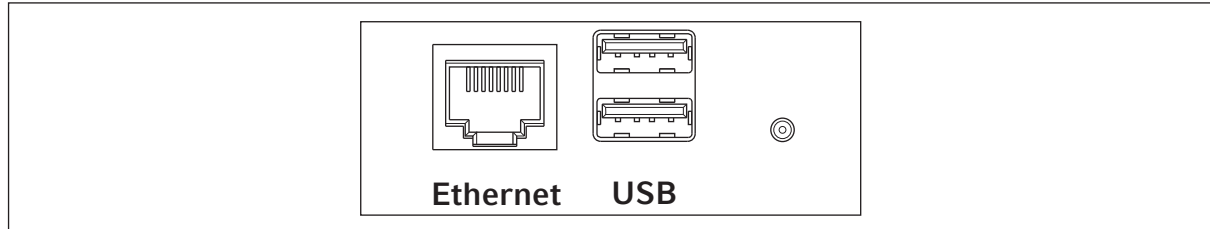

Fig. 3-3: Interfaces epMotion 5070 and epMotion 5070f

Ethernet

Port for the cable to the operating device.

USB

Port for a USB storage medium for firmware updates.

Only connect devices to the interface that comply with the DIN EN 62368-1:2016-05 standards.

3.2 EasyCon tablet

The EasyCon tablet is available for devices up to serial number 7000.

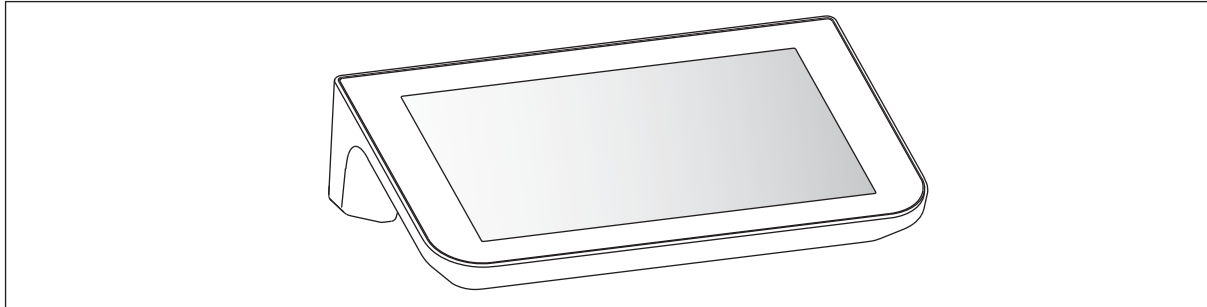

Fig. 3-4: EasyCon tablet

The EasyCon tablet is used to control the epMotion. The EasyCon tablet has a touch screen.

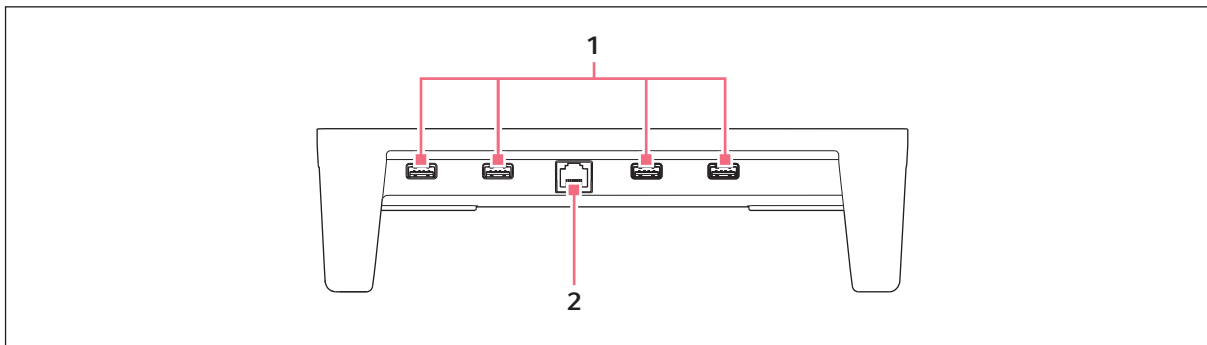

Fig. 3-5: Interfaces EasyCon tablet

1 USB

Port for mouse and USB storage medium

2 Ethernet

Port for the cable to the epMotion

Only connect devices which comply with the DIN EN 62368-1:2016-05 standards to the interfaces.

3.3 MultiCon PC

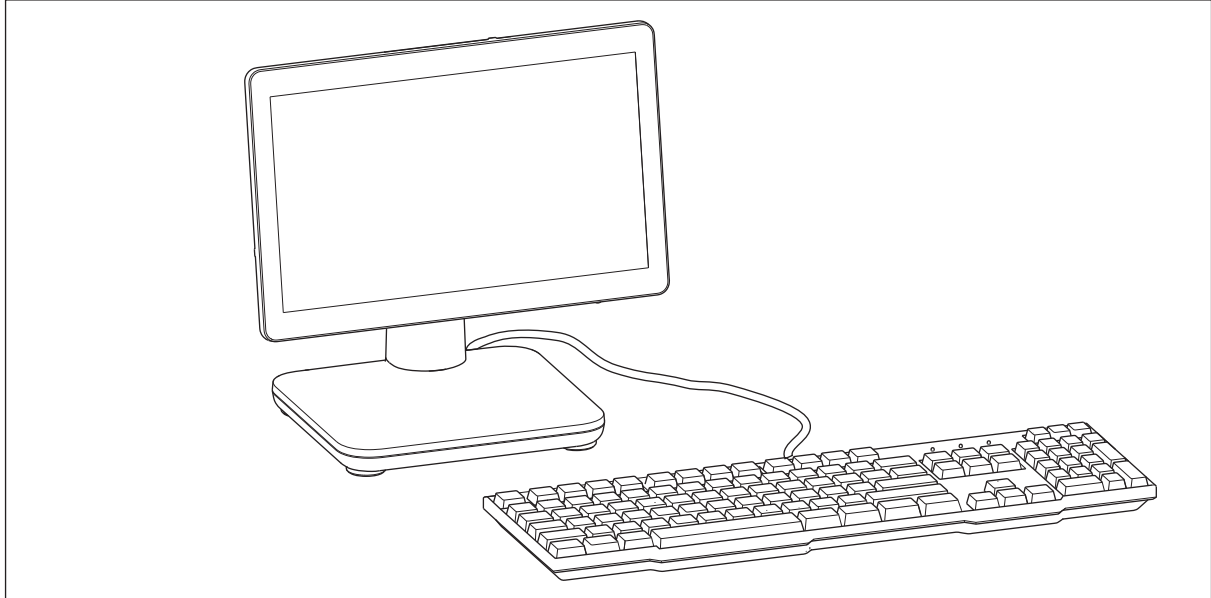

Fig. 3-6: Example depiction MultiCon PC

The MultiCon PC is used to control the *epMotion*. The MultiCon PC has a touch screen.

Information on operation and the interfaces can be found in the manufacturer's original operating manual which is enclosed.

3.4 Delivery package

The epMotion is available in various versions. Your device has been equipped according to your specifications.

3.4.1 epMotion 5070

Quantity	Order no. (International)	Description
1	5070 006.032	epMotion 5070 EasyCon completely contained housing, system incl. EasyCon, epBlue software, mouse, waste box 100 V - 240 V, 50 Hz/60 Hz
or 1	5070 000.282	Automatic liquid handling system epMotion 5070 System with MultiCon PC, mouse, keyboard; accessories; with epBlue software and LH Assistant 100 V - 240 V, 50 Hz/60 Hz

3.4.2 epMotion 5070f

Quantity	Order no. (International)	Description
1	5070 006.108	epMotion 5070f EasyCon system incl. EasyCon, epBlue software, mouse, waste box 100 V - 240 V, 50 Hz/60 Hz
or 1	5070 000.283	Automatic liquid handling system epMotion 5070f System for cleanbench; with MultiCon PC, mouse, keyboard; accessories; with epBlue software and LH Assistant 100 V - 240 V, 50 Hz/60 Hz

3.4.3 Accessories for all versions of the epMotion

Quantity	Order no. (International)	Description
1	–	Mains/power cord Consistent with the country of order or country of destination
1	–	Cable For connecting the control device to the epMotion
1	–	USB cable For connecting USB devices to the control device For epMotion with EasyCon tablet
1	5075 753.006	Waste box for used pipette tips
1	–	Tool for transport securing device
1	5070 900.850	Operating manual epMotion 5070 hardware manual
1	5075 901.250	epBlue with EasyCon tablet software manual
or 1	5075 900.866	epBlue with MultiCon PC software manual

3.4.4 Accessories for epMotion with epBlue ID

Quantity	Order no. (International)	Description
1	–	Software epBlue ID
1	–	Barcode reader With USB cable and table foot
1	5075 003.350	Installation Guide epBlue ID

3.4.5 Accessories for epMotion with epBlue GxP

Quantity	Order no. (International)	Description
1	–	epBlue GxP software
1	–	Documentation folder Folder for certificates and documentation
1	5075 002.353	Installation Guide epBlue GxP
	5075 900.874	Operating manual epBlue GxP

Product description

epMotion® 5070

English (EN)

3.5 Features

The epMotion 5070 is available with different features. All available features are described in this manual.

3.5.1 Principle of operation

The epMotion 5070 is an automatic device for dispensing liquids using dispensing tools and pipette tips.

The epMotion 5070 dispenses liquids in the volume range from 0.2 µL – 1 000 µL.

The dispensing tool aspirates liquid from source positions and dispenses this liquid in destination positions. The dispensing tool works according to the piston stroke principle. For the epMotion, dispensing tools are available for 4 volume ranges.

The epMotion 5070 features an optical sensor. The sensor checks:

- The type and location of labware
- The number and locations of the epT.I.P.S. Motion pipette tips in individual TipHolders and racks by Eppendorf
- Vessel filling levels

The epMotion 5070 can be operated using the MultiCon PC or the EasyCon tablet.

The epMotion 5070 is operated with the epBlue software. You can use the epBlue software to define dispensing processes and compile them into an application. To do so, you select the source positions and destination positions, determine the procedure and define the pattern.

There is a user administration available when working with the MultiCon PC.

3.5.2 Cleanbench

The epMotion 5070f may only be operated in a Cleanbench. The mode of operation corresponds to an epMotion 5070 without a Cleanbench.



For further information on your epMotion, please visit the webpage www.eppendorf.com/automation.

4 Installation

4.1 Selecting the location

Information on ambient conditions, dimensions and weights can be found in the technical data (see *Weight/dimensions on p. 127*).

Select the location of the device according to the following criteria:

Electrical connections

- Mains/power connection as per the name plate.
- The mains/power switch and disconnecting device of the power system circuit (e.g. residual current circuit breaker) can be accessed during operation.

Location

- The ambient conditions match the specifications in the technical data.
- The location is well ventilated.
- The location is protected from direct sunlight.
- The location is protected from UV radiation.
- The location is not near any heat sources, like heaters or drying cabinets.
- There is sufficient space available for the device. The minimum distance to other devices and walls is 6 cm.
- The device can be operated safely and easily at this location.

Workplace

- The lab bench is permanently mounted.
- The lab bench is designed for the weight of the device.
- The lab bench has a horizontal, even work surface.
- The lab bench has a non-skid surface.
- The lab bench is vibration-free.
- There are no vibrating devices on the lab bench.

Cleanbench

- The Cleanbench is 60 cm deep.
- The Cleanbench cables are routed along its side.
- The laminar airflow in the Cleanbench is not affected by the device.
- There are light reflectors on the front screen of the Cleanbench.

4.2 Installing the device



The epMotion may only be installed and put into service by service technicians authorized by Eppendorf.

Information on transport (see *Transport on p. 125*).

5 Hardware

5.1 Worktable for epMotion 5070 and epMotion 5070f

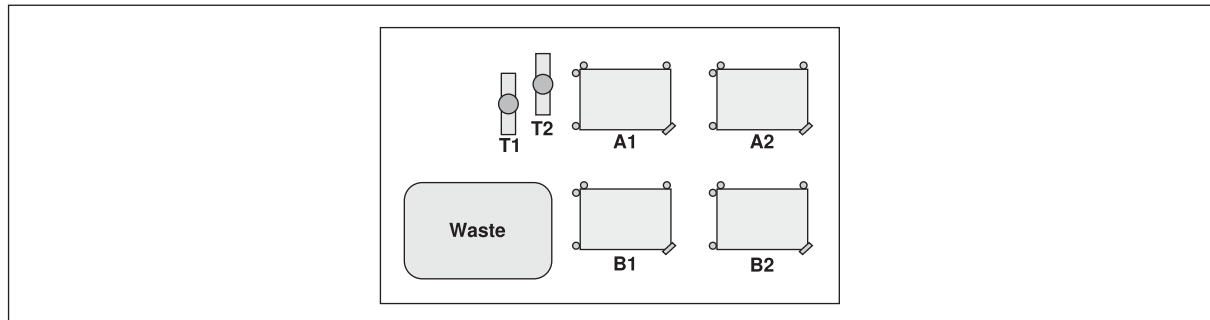

Fig. 5-1: Worktable

A1-B2

Locations for labware

Waste

Location for waste container

T1-T2

Locations for dispensing tools

5.2 Optical sensor

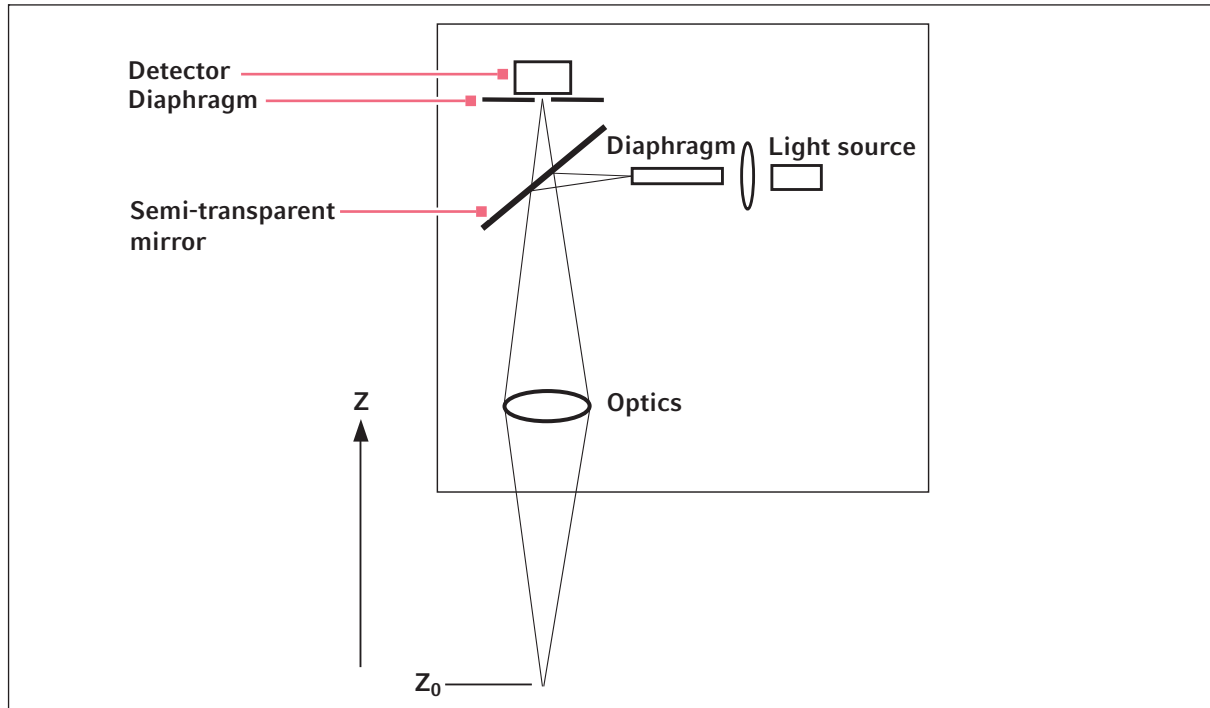

Fig. 5-2: Optical sensor principle

The optical sensor is located on the carrier, to the right of the tool holder.

The optical sensor records the intensity of the reflected light using a lateral infrared light source, a semi-transparent mirror, a fixed lens and travel in the Z-direction. Height z_0 is defined at the point with the highest intensity. This enables the detection of the filling level in a vessel or the presence of labware.

The optical sensor can detect horizontal, plane surfaces. The surface of the liquid must be at an angle of $90^\circ \pm 3^\circ$ to the optical axis.

The surfaces of liquids can be curved due to the vessel geometry or the physical properties of the liquid or vessel. The optical sensor may not detect the filling level on curved surfaces. If this is the case, the user must enter the liquid volume.

The optical sensor has a detection limit for the filling level of vessels. The detection limit depends on the vessel geometry. As a rule, filling levels of 3 mm or higher can be detected.

The optical sensor has the following functions:

Measuring the filling level in the labware

- The optical sensor measures the filling level in labware locations. There are two options.
 - The optical sensor measures the filling level in all locations used.
 - The optical sensor measures the filling level in the first location, in the last location and in 8 randomly determined locations.
- The optical sensor cannot measure the filling level in the following labware:
 - 384-well plates
 - Qiagen Rotor-Disc 72, Qiagen Rotor-Disc 100
 - LiquidWasteTub

Detecting pipette tips

- The optical sensor determines the quantity and the positions of the ep.T.I.P.S. pipette tips. Motion pipette tips in TipHolders and racks by Eppendorf.
- If there are too few pipette tips on the epMotion worktable, epBlue will prompt you to refill pipette tips.

Checking the labware on the worktable

- The optical sensor scans the code on the labware.
- epBlue checks if the labware on the epMotion worktable matches the labware on the epBlue worktable.
- If a required labware is not available on the epMotion worktable, epBlue will prompt you to position the labware.
- The optical sensor checks all the locations in which labware is positioned. The optical sensor does not check any locations which are empty in the application.



Information on setting the optical sensor and a detailed description of all functions can be found in the software manual.

5.3 Tools



NOTICE! Damage to the gold contacts from handling.

If the gold contacts of the tool are damaged or contaminated this will damage the tool.

- ▶ Do not touch the gold contacts.

The tool holder picks up a dispensing tool and puts it down again. The tool holder detects the dispensing tool from its gold contacts.

5.3.1 Dispensing tools

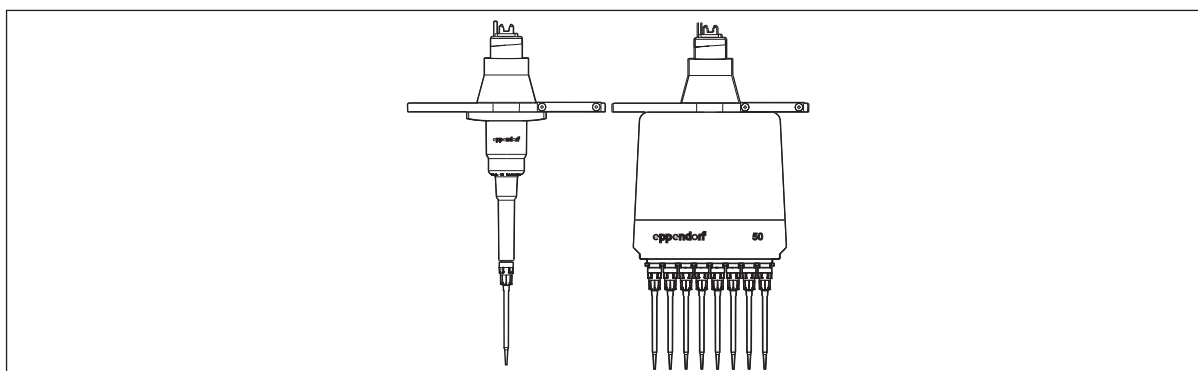

Fig. 5-3: Single-channel dispensing tool and eight-channel dispensing tool

Dispensing tools are piston-stroke pipettes. The principle of operation of the dispensing tools is described in chapter (see *Dispensing liquids on p. 39*).

Single-channel dispensing tools and eight-channel dispensing tools with 4 volume ranges each are available for the epMotion.

Tab. 5-1: Volume range of the dispensing tools

Single-channel dispensing tool	Eight-channel dispensing tool	Volume range
TS 10	TM 10-8	0.2 µL – 10 µL
TS 50	TM 50-8	1 µL – 50 µL
TS 300	TM 300-8	20 µL – 300 µL
TS 1000	TM 1000-8	40 µL – 1000 µL

The errors of measurement of the dispensing tools can be found in the technical data (see p. 130).

Help on dispensing errors can be found in the Maintenance chapter (see *Dispensing error on p. 122*).

5.4 Barcode reader

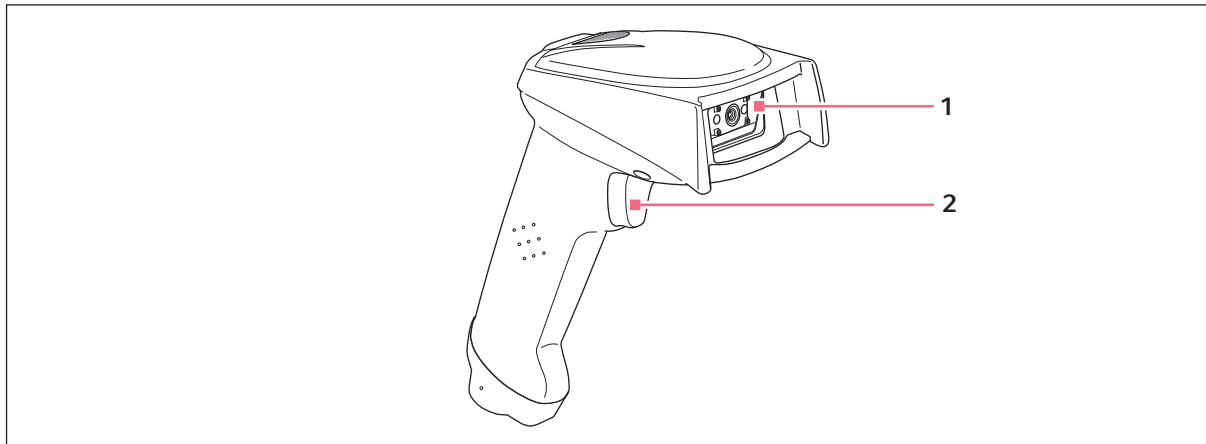

Fig. 5-4: Model of a barcode reader

1 Window

2 Key

You can use the barcode reader to track and document your samples via IDs.

The barcode reader is connected to a USB interface on the MultiCon PC.

Plates have an ID. The ID of a well is generated automatically from the ID of the plate and the identification of the well. Racks do not have an ID. Each tube in a rack has an ID.

The barcode reader has 2 settings:

- Manual entry: To read an ID, press a key on the barcode reader.
- Automatic Entry: To read an ID, hold the barcode reader to the ID. The barcode reader detects the ID automatically.

6 Dispensing liquids

6.1 Operation of the dispensing tools

Dispensing tools are piston-stroke pipettes. If the piston moves downward in the dispensing tool, liquid will be dispensed from the pipette tip. If the piston moves upward in the dispensing tool, liquid will be aspirated into the pipette tip. The piston is moved by a motor in the tool holder.

Dispensing tools are air-cushioned. There is an air cushion between the piston and the liquid.

On eight-channel dispensing tools, all 8 channels move simultaneously.

You can dispense liquids in the *Pipette*, *Multidispense* and *Multiaspirate* modes.

6.1.1 Dispensing modes

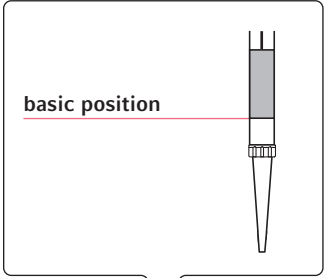
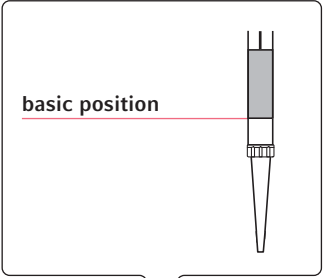
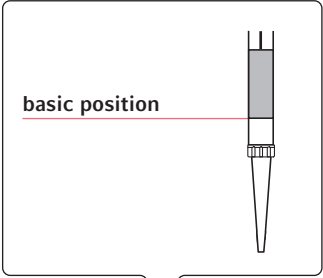
<i>Pipette</i> dispensing mode	<i>Multidispense</i> dispensing mode	<i>Multiaspirate</i> dispensing mode
In <i>Pipette</i> mode, a defined volume is aspirated and fully dispensed in one step.	In <i>Multidispense</i> mode, a volume is aspirated and dispensed in defined dispensing steps.	In <i>Multiaspirate</i> mode, a volume is aspirated in defined steps and fully dispensed in one step.
		
The piston is in the basic position.	The piston is in the basic position.	The piston is in the basic position.

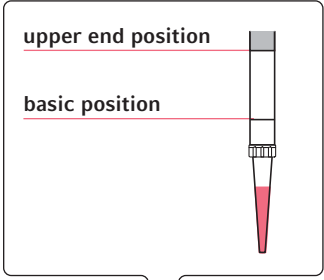
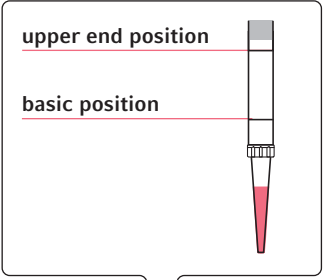
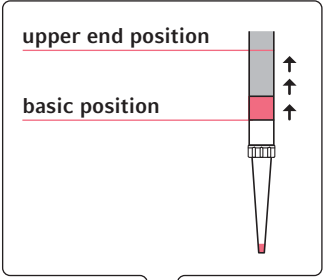
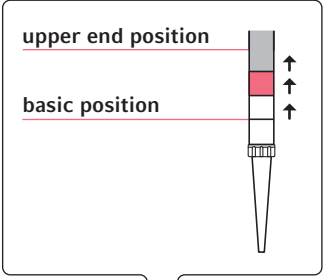
<i>Pipette dispensing mode</i>	<i>Multidispense dispensing mode</i>	<i>Multiaspirate dispensing mode</i>
<div data-bbox="204 385 528 663" style="border: 1px solid black; padding: 5px;">  </div> <div data-bbox="193 745 563 875" style="margin-top: 10px;"> <p>In order to aspirate the volume, the piston moves from the basic position to the upper end position.</p> </div>	<div data-bbox="608 385 932 663" style="border: 1px solid black; padding: 5px;">  </div> <div data-bbox="596 745 979 943" style="margin-top: 10px;"> <p>In order to aspirate the volume, the piston moves from the basic position to beyond the upper end position. More volume is aspirated than is needed for the dispensing steps.</p> </div>	<div data-bbox="1011 385 1335 663" style="border: 1px solid black; padding: 5px;">  </div> <div data-bbox="1000 745 1367 842" style="margin-top: 10px;"> <p>To aspirate the defined volume, the piston moves upwards a bit from the home position.</p> </div>
		<div data-bbox="1011 967 1335 1245" style="border: 1px solid black; padding: 5px;">  </div> <div data-bbox="1000 1328 1383 1525" style="margin-top: 10px;"> <p>The dispensing tool moves to vessel height. To avoid liquids dripping from the pipette tip, the piston moves up a defined distance. Air is aspirated into the pipette tip.</p> </div>

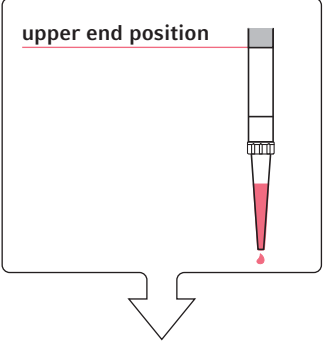
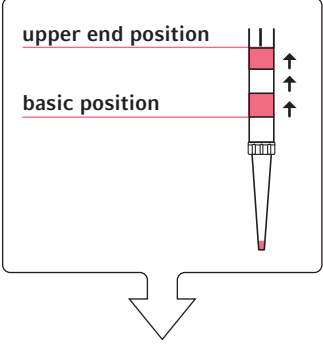
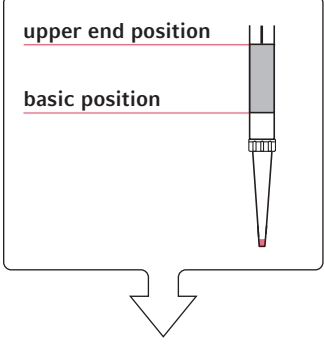
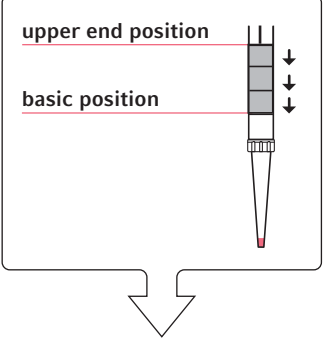
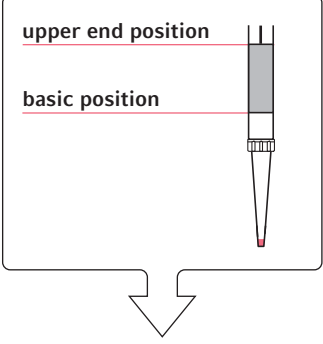
<i>Pipette dispensing mode</i>	<i>Multidispense dispensing mode</i>	<i>Multiaspirate dispensing mode</i>
	 <p>The piston is moved to a defined position. For this, the piston moves to the upper end position (reverse stroke). Volume is dispensed into the source position.</p>	 <p>The dispensing tool moves downward and is immersed into the liquid. To aspirate the defined volume, the piston moves upwards a bit from the home position.</p>
 <p>To dispense the volume, the piston moves from the upper end position to the basic position in one step. When the piston is in the basic position, there is still a remaining volume in the pipette tip. The remaining volume is part of the volume of this pipetting procedure.</p>	 <p>The piston moves from the upper end position to the basic position in defined dispensing steps. The same volume is dispensed with each dispensing step. When the piston is in the basic position, there is still a remaining volume in the pipette tip. The remaining volume is not part of the volume for the dispensing steps.</p>	 <p>To dispense the volume, the piston moves from the upper end position to the basic position in one step. When the piston is in the basic position, there is still a remaining volume in the pipette tip. The remaining volume is part of the volume of this pipetting procedure.</p>

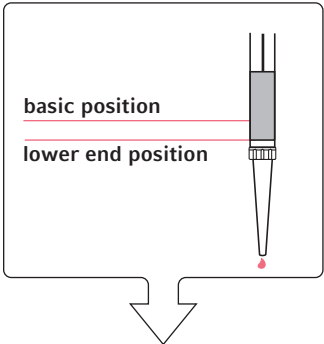
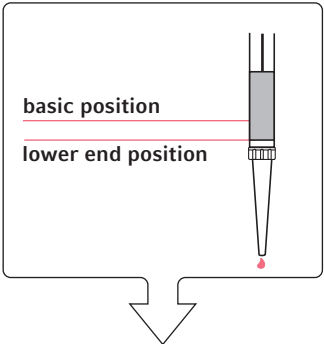
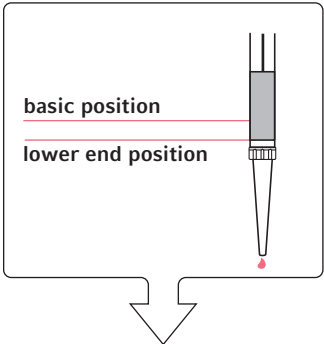
<i>Pipette dispensing mode</i>	<i>Multidispense dispensing mode</i>	<i>Multiaspirate dispensing mode</i>
 <p>The piston moves to the lower end position (remaining stroke). The remaining volume is dispensed into the destination position.</p>	 <p>The piston moves to the lower end position (remaining stroke). The remaining volume is dispensed. If the pipette tip is replaced before each liquid aspiration, the remaining volume is dispensed into the waste container. If the pipette tip is not replaced before each liquid aspiration, the remaining volume is dispensed into the source position.</p>	 <p>The piston moves to the lower end position (remaining stroke). The remaining volume is dispensed into the destination position.</p>

6.1.2 Volume aspiration in the *Multidispense* dispensing mode

The aspirated volume depends on the dispensing tool. The epBlue software automatically calculates the volume to be aspirated.

Dispensing tool	Volume per channel for reverse stroke	Volume per channel for remaining stroke
TS 10 single-channel dispensing tool	1.8 µL	0.8 µL
TM 10-8 eight-channel dispensing tool	1.8 µL	0.8 µL
TS 50 single-channel dispensing tool	5.8 µL	2.5 µL
TM 50-8 eight-channel dispensing tool	5.8 µL	2.5 µL
TS 300 single-channel dispensing tool	16.7 µL	3.7 µL
TM 300-8 eight-channel dispensing tool	45.2 µL	5.0 µL
TS 1000 single-channel dispensing tool	50.3 µL	35.2 µL
TM 1000-8 eight-channel dispensing tool	50.3 µL	35.2 µL

The reverse stroke and remaining stroke are identical for all liquid types.

6.1.3 Calculating the volume aspiration in the *Multidispense* dispensing mode

A 96-well plate is to be filled with 10 µL of water per location by dispensing. The TM 50-8 eight-channel dispensing tool is used. The volume is taken from a reservoir. The pipette tips are not replaced before a new volume aspiration.

Sum of the volumes for dispensing:

- $96 \times 10 \text{ µL}$ for 96-well plate: 960 µL
- $8 \times 5.8 \text{ µL}$ reverse stroke: 46.4 µL
- $8 \times 2.5 \text{ µL}$ remaining stroke: 20 µL
- Sum: **1026.4 µL**

6.1.4 Mixing liquids

Liquids can be mixed by multiple pipetting.

A mixing cycle consists of one upward movement and one downward movement of the piston in the dispensing tool.

The aspiration and dispensing levels of the liquid can be defined when mixing. Use a defined level if the volume in the vessel is smaller than the working volume. If the volume in the vessel is greater than the working volume, the vessel may overflow.

During the mixing process, the pipette tip is immersed in the liquid. After mixing, the remaining volume is dispensed above the liquid level.

Mixing speeds are defined in the liquid types. When using your own settings, carry out trials to determine the mixing speeds.



NOTICE! Contamination of the dispensing tool due to excessive high mixing speeds.

If the mixing speed is too high, liquid may enter the dispensing tool.

- ▶ If the liquid has a low viscosity or tends to foam, set low mixing speeds.
 - ▶ Test the mixing parameters using demineralized water.
 - ▶ Use pipette tips with filters.
-

6.2 Bottom tolerance

The bottom tolerance is the minimum distance between the vessel base and the lower end of the pipette tip.

The bottom tolerance compensates any manufacturing variations of the labware and ensure the safe movement of the pipette tip in the vessel.

The pipette tip moves down inside the vessel until it has reached the bottom tolerance. The pipette tip cannot aspirate any volume that is within the bottom tolerance. The remaining volume remains in the vessel.

Standard for bottom tolerance:

- General labware: 1 mm
- 30 mL and 100 mL reservoirs: 2.5 mm

You can change the bottom tolerance. The bottom tolerance of labware is set in the *labware editor*. The bottom tolerance can be set in the *Application Editor* for each step of an application. Decreasing the bottom tolerance also reduces the remaining volume.

There is a special procedure for pipetting below the bottom tolerance. For this procedure you need to measure the labware for which you want to pipette below the bottom tolerance. This is to check where the bottom of this labware is located. You can find a detailed description of this function in the *epMotion* software manual.

- ▶ Do not decrease the bottom tolerance on uneven plates.
- ▶ Check the set bottom tolerance when exchanging pipette tips, plates or vessels.

6.3 Liquid aspiration

The *epMotion* offers several options for aspirating liquid.

Make sure that only the pipette tip is immersed into the vessel. If the dispensing tool is immersed into the vessel, the dispensing tool can become contaminated. This risk of contamination is particularly high if you are working with 10 µL and 50 µL pipette tips in high or large vessels. Examples: 10 µL pipette tips in a 30 mL reservoir. 10 µL pipette tips in 1.5 mL and 2 mL size vessels.

6.3.1 Liquid aspiration with a constant immersion depth (Default)

Liquid aspiration with a constant immersion depth is set as the default in the software

Parameters:

- Immersion depth of the pipette tip: according to the liquid type
- Reduced immersion depth of the pipette tip: 0.7 mm.
- Additional movement of the pipette tip: The pipette tip moves down during liquid aspiration.
- Bottom tolerance of the labware: Standard 1 mm. The bottom tolerance can be adjusted for each type of labware.

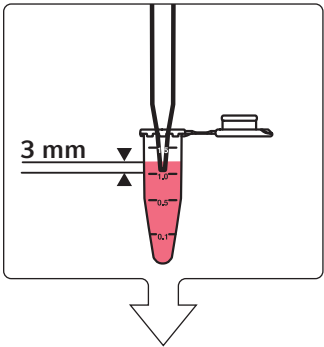
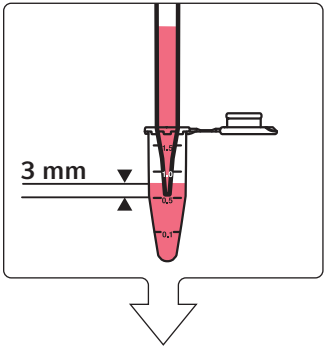
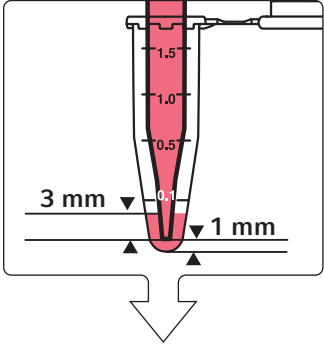
<p>Start position</p> 	<p>The pipette tip is immersed into the liquid. The immersion depth of the pipette tip is defined in the liquid type, e.g. 3 mm.</p>
<p>Movement 1</p> 	<p>The pipette tip aspirates liquid. The filling level in the vessel falls, the pipette tip moves down simultaneously. The immersion depth of the pipette tip remains constant.</p>
<p>Movement 2</p> 	<p>The pipette tip moves down until it has reached the bottom tolerance of 1 mm.</p>

End position

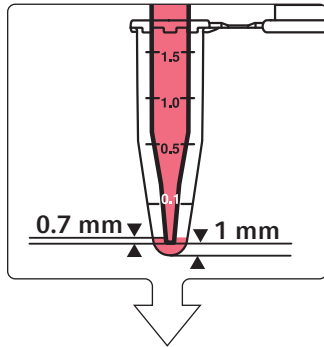

The pipette tip continues to aspirate liquid. The immersion depth of the pipette tip is reduced, e.g. from 3 mm to 0.7 mm.

The liquid aspiration is ended when the pipette tip is at the same height as the bottom tolerance of 1 mm and when it has an immersion depth of 0.7 mm. The remaining volume stays in the vessel.

Remaining volume = bottom tolerance + immersion depth. In the example this is 1.7 mm.

Liquid aspiration with a constant immersion depth can be activated in the software using the *Default* option (refer to the epMotion software manual).



If the liquid is aspirated up to the remaining volume, the curvature of the liquid level can lead to errors during dispensing.

6.3.2 Liquid aspiration from the vessel base (*Aspirate from bottom*)

Parameters:

- Immersion depth of the pipette tip: Up to the height of the bottom tolerance.
- Additional movement of the pipette tip: The position of the pipette tip does not change.
- Bottom tolerance of the labware: Standard 1 mm. The bottom tolerance can be adjusted for each type of labware.

Liquid aspiration from the vessel base is recommended in the following cases:

- For vessels ≤ 0.5 mL, 96-well plates and 384-well plates.
- For plates with different filling levels in the locations.
- For vessels with low filling volumes.

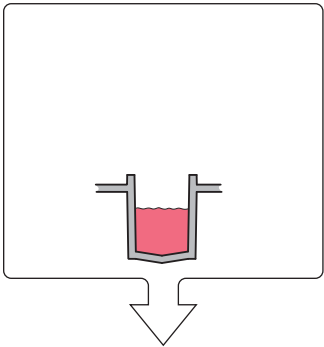
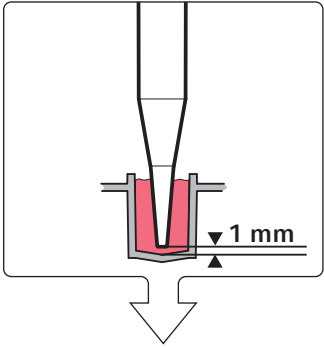
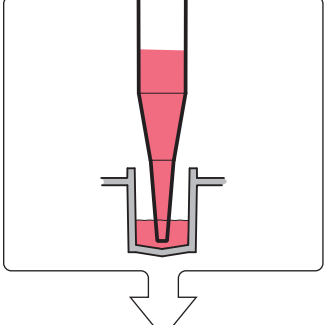
<p>Start position 1</p> 	<p>The vessel is filled no further than the working volume.</p>
<p>Start position 2</p> 	<p>The pipette tip is immersed into the liquid up to the bottom tolerance, e.g. 1 mm. The filling level in the vessel rises no further than the filling volume.</p>
<p>Movement</p> 	<p>The pipette tip aspirates liquid, the filling level in the vessel falls. The pipette tip does not change its position.</p>

Dispensing liquids

epMotion® 5070

English (EN)

End position

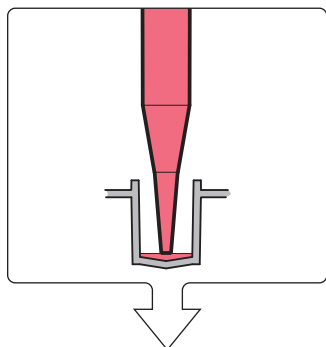

The liquid aspiration is ended when the pipette tip is at the same height as the bottom tolerance of 1 mm.

The remaining volume with a height of 1 mm remains in the vessel.

Liquid aspiration from the vessel base can be activated in the software using the *Aspirate from bottom* option (refer to the epMotion software manual).



If the liquid is aspirated up to the remaining volume, the curvature of the liquid level can lead to errors during dispensing.

6.3.3 Liquid aspiration from a defined position

The pipette tip is in a defined position in the vessel. The position of the pipette tip is determined from the vessel base or from the liquid level.

During liquid aspiration, the pipette tip can perform the following movements:

- *Default*: During liquid aspiration, the pipette tip moves uniformly downwards with a constant immersion depth.
- *Custom*: The pipette tip moves for a defined distance.
- *Fix*: The pipette tip remains in a defined position.

Liquid aspiration from a defined position is recommended in the following cases:

- For liquids with different phases.
- For liquid aspiration above a pellet.



CAUTION! Sample loss due to incorrect immersion depth.

If the immersion depth of the pipette tip is incorrect, this may result in a sample loss, e.g. due to liquid displacement.

- ▶ Use the *Surface Teaching* function to check that position of the pipette tip is correct.
- ▶ Perform a test run to check that the position of the pipette tip and the immersion depth are correct.



The filling volume of each vessel is defined in the application.
The bottom tolerance is defined in the labware properties.
Other values for liquid aspiration are defined in the liquid type, e.g. aspiration speed.

6.3.3.1 Liquid aspiration with a constant immersion depth (*Aspirate from defined height > Default*)

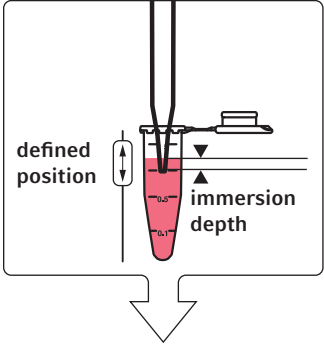
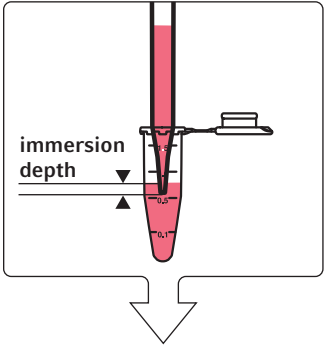
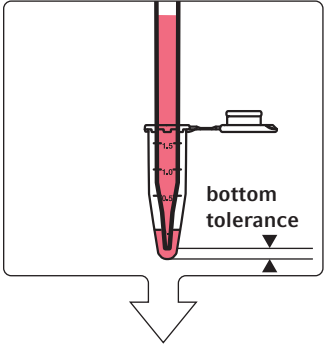
<p>Start position</p> 	<p>The user defines the position of the pipette tip in the vessel. The immersion depth of the pipette tip in the liquid is calculated using the defined position.</p>
<p>Movement</p> 	<p>The pipette tip aspirates liquid. The pipette tip moves with the liquid level according to the liquid type settings.</p>
<p>End position</p> 	<p>The pipette tip moves down until it has reached the bottom tolerance. The pipette tip continues to aspirate liquid. The immersion depth of the pipette tip is reduced, e.g. from 2 mm to 0.7 mm. The liquid aspiration is ended when the pipette tip is at the same height as the bottom tolerance and when it has an immersion depth of 0.7 mm. The remaining volume stays in the vessel. Remaining volume = bottom tolerance + immersion depth.</p>

Liquid aspiration with a constant immersion depth can be activated in the software using the *Aspirate from defined height > Default* option (refer to the epMotion software manual).

Perform a test run to check that the immersion depth is correct.

6.3.3.2 Liquid aspiration on a defined distance (*Aspirate from defined height > Custom*)

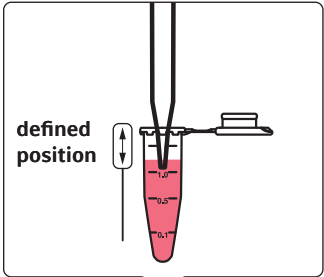
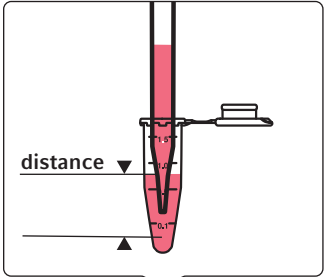
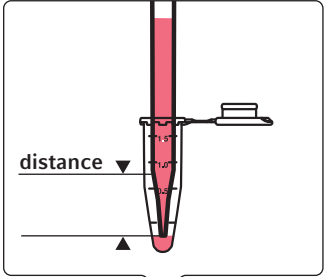
<p>Start position</p> 	<p>The user defines the position of the pipette tip in the vessel.</p>
<p>Movement</p> 	<p>The user defines the distance the pipette tip travels. The pipette tip can move up or down. The pipette tip travels the defined distance and aspirates liquid during this process. The filling level in the vessel rises. The immersion depth of the pipette tips changes in line with the defined distance and the liquid type settings, e.g. aspiration speed.</p>
<p>End position</p> 	<p>The movement of the pipette tip ends when the pipette tips has travelled the defined distance. Liquid aspiration is ended when the pipette tip has aspirated the defined amount of fluid.</p>

Liquid aspiration on a defined distance can be activated in the software using the *Aspirate from defined height > Custom* option (refer to the epMotion software manual).

Perform a test run to check that the immersion depth is correct.

6.3.3.3 Liquid aspiration from a defined position (*Aspirate from defined height > Fix*)

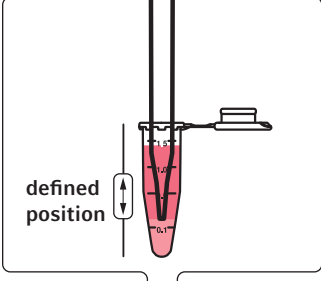
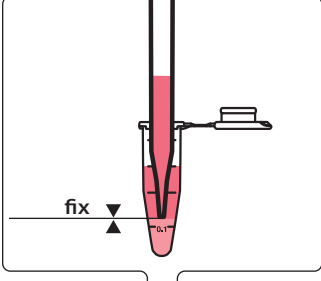
<p>Start position</p> 	<p>The user defines the position of the pipette tip in the vessel.</p>
<p>Movement and end position</p> 	<p>The pipette tip aspirates liquid. The filling level in the vessel rises. The pipette tip does not change its position. The immersion depth of the pipette tip reduces in line with the aspirated amount of fluid. The pipette tip aspirates liquid until the defined amount of fluid has been aspirated.</p>

Liquid aspiration from a defined position can be activated in the software using the *Aspirate from defined height > Fix* option (refer to the epMotion software manual).

Perform a test run to check that the immersion depth is correct.

6.4 Transporting the liquid

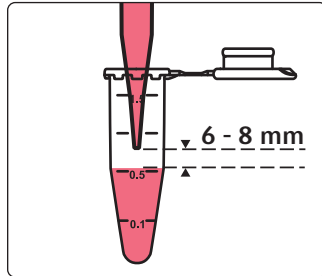

Before transport, the pipette tip goes into a defined position above the surface of the liquid, e.g. 6 mm. The position of the pipette above the surface of the liquid is defined in the liquid type. The distance corresponds to the position in which the pipette tip dispenses the liquid in a free jet.

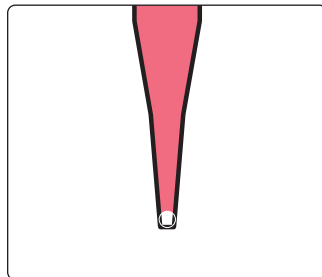

Once the pipette has reached the position, the liquid is retracted into in the pipette tip. An area filled with air is created in the lower part of the pipette tip. The liquid does not drip during transport. If the liquid was aspirated from a filter plate, bubbles may form at the lower end of the pipette tip during transport. The bubbles are of different sizes.

6.5 Liquid dispensing

The epMotion provides several options to dispense liquid from the pipette tip.

6.5.1 Liquid dispensing in a free jet (*Default*)

Liquid dispensing in a free jet is set as the default in the software.

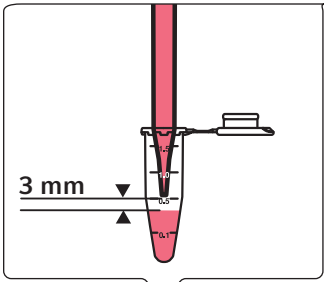
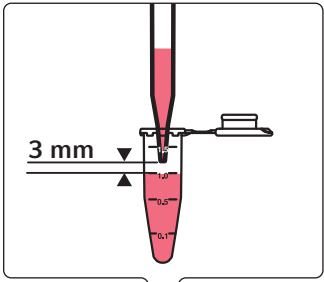
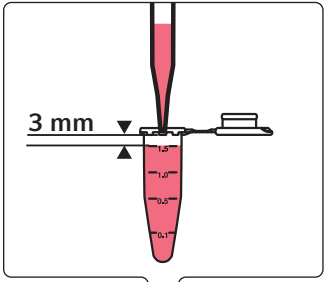
<p>Start position</p> 	<p>The pipette tip moves to a defined position above the surface of the liquid. The location is defined in the liquid type.</p> <p>The example shows the liquid type water. In this case, the distance is 3 mm.</p> <p>For the liquid type Protein C, the distance is 5 mm.</p> <p>This setting takes into account the tendency of concentrated protein solutions to form foam.</p>
<p>Movement</p> 	<p>The pipette tip dispenses the liquid into the vessel in a free jet.</p> <p>The filling level in the vessel rises, the pipette tip moves up simultaneously.</p> <p>The distance between the pipette tip and the liquid level remains constant.</p>
<p>End position</p> 	<p>The pipette tip moves up no further than the edge of the vessel.</p> <p>Liquid dispensing is ended when the pipette tip has dispensed the defined amount of fluid. The vessel can be filled up to the filling volume.</p>

You can activate liquid dispensing in a free jet in the software using the *Default* function (refer to the epMotion software manual).

6.5.2 Liquid dispensing with contact to the surface (*Default*)

For certain types of liquid and the dispensing tool for 10 µL, liquid dispensing with contact to the surface replaces dispensing in a free jet. Liquid is dispensed onto the surface of the liquid or the surface of the vessel. Eppendorf AG recommends contact dispensing for dispensing volumes of <1 µL.

Prerequisites:

- Dispensing tool TS 10 or TM 10-8
- A suitable dispensing volume
- A suitable type of liquid

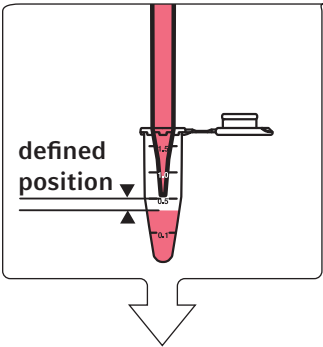
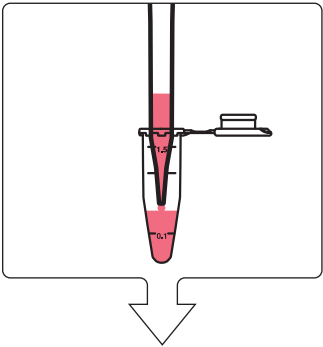
<p>Start position</p> 	<p>The pipette tip moves to a defined location. The distance between the pipette tip and the surface is very small. The location is defined in the liquid type.</p>
<p>Dispensing position</p> 	<p>The pipette tip places a drop on the surface. The contact with the surface causes the drop to separate from the pipette tip. The drop can be placed on the surface of a liquid (wet contact dispensing) or on the surface of a vessel (dry contact dispensing).</p>

You can activate liquid dispensing in the software using the *Default* function (refer to the epMotion software manual).

6.5.3 Liquid dispensing at the height of the edge of the vessel (*Dispense from top*)

Liquid dispensing at the height of the edge of the vessel minimizes the risk of contaminating the pipette tip.

Liquid dispensing at the height of the edge of the vessel is recommended in the following cases:

- Quick dispensing.
- Liquid dispensing in vessels with small diameters, e.g. 384-well plates, capillaries.
- Liquid dispensing in plates with very different filling levels in the locations.

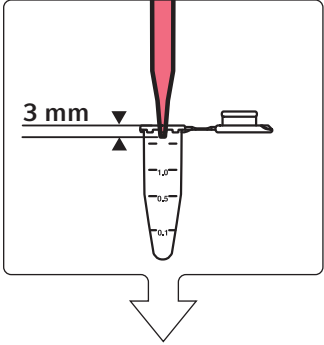
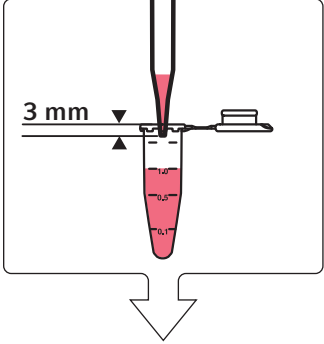
	<p>The pipette tip is 3 mm – 4 mm below the edge of the vessel.</p>
	<p>The pipette tip dispenses the liquid into the vessel in a free jet. The filling level in the vessel rises, the position of the pipette tips does not change. Liquid dispensing is ended when the pipette tip has dispensed the defined amount of fluid. The vessel can be filled up to the filling volume.</p>

You can activate liquid dispensing at the height of the edge of the vessel in the software using the *Dispense from top* function (refer to the epMotion software manual).

6.5.4 Liquid dispensing from a defined position

The pipette tip is in a defined position in the vessel. The position of the pipette tip is determined from the vessel base or from the liquid level.

The pipette tip can dispense the liquid above a liquid, into a liquid or onto the vessel base.

During liquid dispensing, the pipette tip can perform the following movements:

- During liquid dispensing, the pipette tip moves uniformly upwards with a constant immersion depth.
- The pipette tip moves for a defined distance.
- The pipette tip remains in the selected position.

Liquid dispensing from a defined height is recommended in the following cases:

Above a liquid

- Liquid dispensing into plates. The locations of the plate have different filling levels.
- Liquid dispensing into HPLC vials

Into a liquid (wet contact dispensing)

- Dispensing of low-volume, highly viscous solutions which are difficult to release from the pipette tip
- Protein crystallization
- Hanging-drop cell-culture plates

Onto the vessel base (dry contact dispensing)

- Liquid dispensing onto a punch on the vessel base.
- Liquid dispensing onto microarrays.



The filling volume of each vessel is defined in the application.

The bottom tolerance is defined in the labware properties.

Other values for liquid aspiration are defined in the liquid type, e.g. aspiration speed.

6.5.4.1 Liquid dispensing with a constant immersion depth (*Dispense from defined height > Default*)

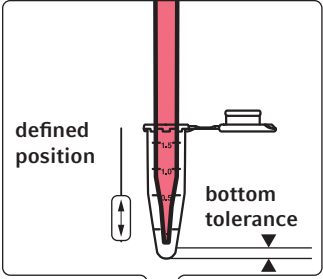
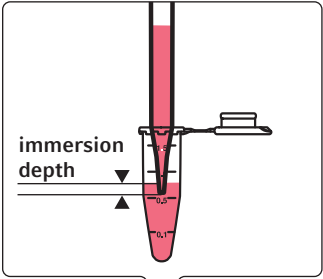
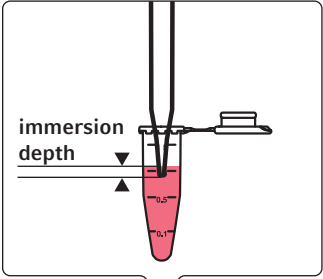
<p>Start position</p> 	<p>The user defines the position of the pipette tip in the vessel. The pipette tip can be positioned below the bottom tolerance.</p>
<p>Movement</p> 	<p>The pipette tip dispenses liquid. The filling level in the vessel rises, the pipette tip moves uniformly upwards. The immersion depth remains constant.</p>
<p>End position</p> 	<p>Liquid dispensing is ended when the pipette tip has dispensed the defined amount of fluid. The vessel can be filled up to the filling volume.</p>

You can activate liquid aspiration from a defined position in the software using the function *Dispense from defined height > Default* (refer to the epMotion software manual).

Perform a test run to check that the immersion depth is correct.

6.5.4.2 Liquid dispensing on a defined distance (*Dispense from defined height > Custom*)

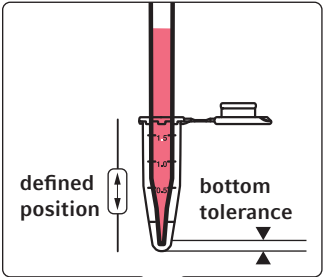
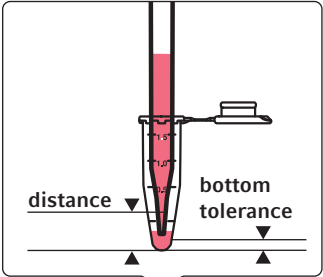
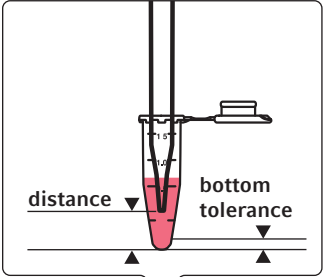
<p>Start position</p> 	<p>The user defines the position of the pipette tip in the vessel. The pipette tip can be positioned below the bottom tolerance.</p>
<p>Movement</p> 	<p>The user defines the distance the pipette tip travels. The pipette tip can move up or down. The pipette tip travels the defined distance and dispenses liquid during this process. The filling level in the vessel rises. The immersion depth of the pipette tips changes in line with the defined distance and the liquid type settings, e.g. the dispensing speed.</p>
<p>End position</p> 	<p>The movement of the pipette tip ends when the pipette tips has travelled the defined distance. Liquid dispensing is ended when the pipette tip has dispensed the defined amount of fluid. The vessel can be filled up to the filling volume.</p>

You can activate liquid aspiration from a defined position in the software using the function *Dispense from defined height > Custom* (refer to the epMotion software manual).

Perform a test run to check that the immersion depth is correct.

6.5.4.3 Liquid dispensing from a defined position (*Dispense from defined height > Fix*)

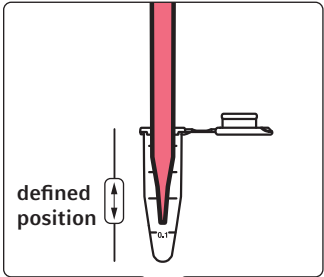
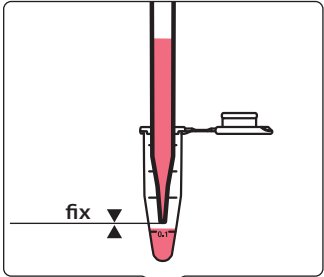
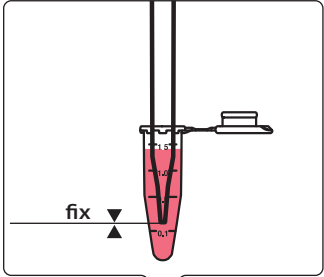
<p>Start position</p> 	<p>The user defines the position of the pipette tip in the vessel. The pipette tip can be positioned below the bottom tolerance.</p>
<p>Movement</p> 	<p>The pipette tip dispenses liquid. The filling level in the vessel rises. The pipette tip does not change its position. The immersion depth of the pipette tips may increase when the filling level rises.</p>
<p>End position</p> 	<p>Liquid dispensing is ended when the pipette tip has dispensed the defined amount of liquid. The vessel can be filled up to the filling volume.</p>

You can activate liquid aspiration from a defined position in the software using the function *Dispense from defined height > Fix* (refer to the epMotion software manual).

Perform a test run to check that the immersion depth is correct.

7 Labware – vessels, plates and pipette tips

The term *Labware* refers to consumables and accessories for the epMotion. Consumables are vessels, plates and pipette tips. Accessories include adapters, blocks and racks. epBlue includes a definition for labware that is placed on the epMotion worktable. The definition includes data on the geometry, temperature control, volume and bottom tolerance of the labware.



The epMotion works with labware from different manufacturers. Information on how to expand the labware library can be found in the software manual.



Labware may not exceed an overall height of 147 mm. If this height is exceeded, epBlue generates an error message.

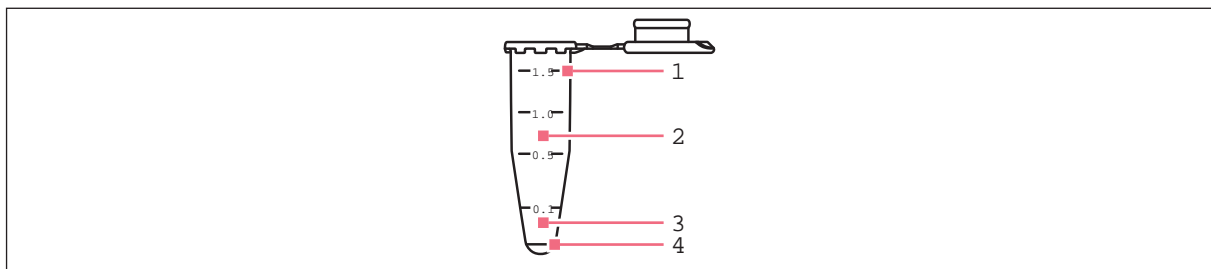

Fig. 7-1: Tube with lid

1 Filling volume

3 Detection limit of optical sensor

2 Working volume

4 Remaining volume

7.1 Tubes

Tubes must be inserted in racks. You can use any type of tube which fits in an epMotion rack.

Tubes that can be inserted into a rack:

- Eppendorf Safe-Lock tubes
- Standard 3810X tubes
- PCR tubes
- Conical tubes/centrifuge tubes
- Cryogenic tubes

Level measurement with the optical sensor is more difficult with 0.2 mL and 0.5 mL tubes.

Use thermoracks or ReservoirRack modules if you want to temper tubes.

7.2 Plates

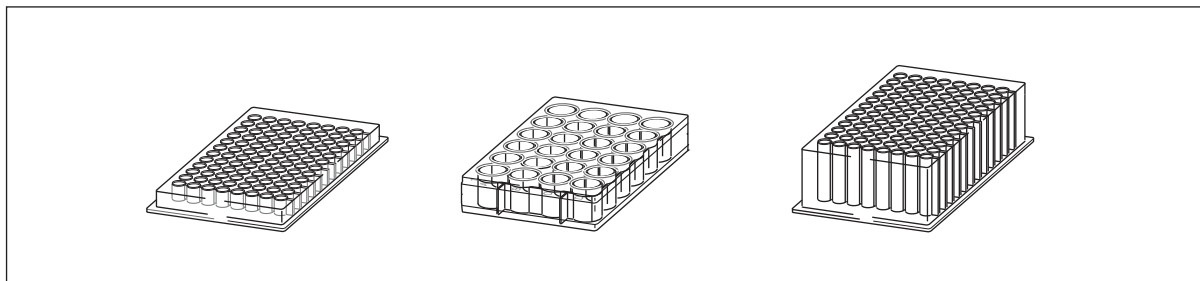

Fig. 7-2: Plates: left – 96-well Microplate, center – 24-well Microplate, right – 96-well Deepwell plate

The following plates are available for the epMotion:

- PCR plates with 96 and 384 wells
- Deepwell plates with 24, 96 and 384 wells
- Microplate with 6, 24, 48, 96 and 384 wells
- Plates with 96 individual tubes (tube plates)

Stacking plates

- You can stack plates of the same type on the worktable.



- ▶ Only stack plates supplied by Eppendorf AG.
Plates from other manufacturers may have different dimensions.

7.2.1 PCR plates

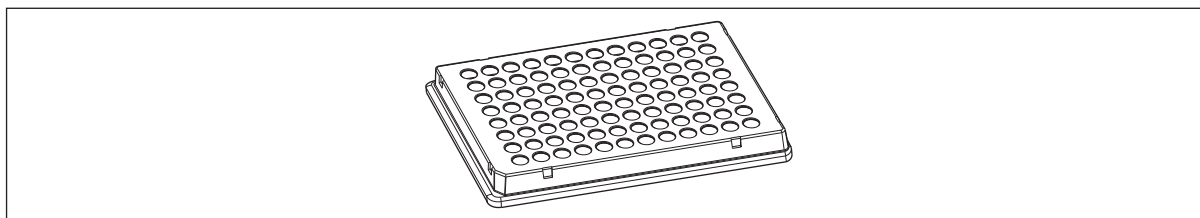

Fig. 7-3: 96-well PCR plate

The following PCR plates are available for the epMotion:

- 96-well PCR plates of the skirted, semi-skirted, unskirted type
- 384-Well-PCR plates of the skirted type

Level measurement using the optical sensor is not recommended for 96-well PCR plates. Level measurement using the optical sensor is not possible with 384-well PCR plates.

Tab. 7-1: Use of Thermoblocks

96-well PCR plates, semi-skirted	Thermoblock PCR 96 OC, Thermoblock PCR 96
96-well PCR plates, unskirted	Thermoblock PCR 96

Tab. 7-2: Placing and transporting PCR plates

	Thermoblock	Adapter	Worktable
96-well PCR plates, skirted	Manual placement is possible. The gripper can grip plates which are placed on a thermoblock. The gripper can transport the plates individually. The gripper can transport the plate and the thermoblock together.	Manual placement is possible. The gripper can grip plates which are placed on an adapter. The gripper transports the plate. Adapters are not transported.	They can be placed manually or using the gripper. The gripper transports the plate.
96-well PCR plates, semi-skirted	Manual placement is possible. The gripper can grip plates which are placed on a thermoblock. The gripper can transport the plates individually. The gripper can transport the plate and the thermoblock together.	Manual placement is possible. The gripper can grip plates which are placed on an adapter. The gripper transports the plate. Adapters are not transported.	They cannot be placed on the worktable. The plate cannot be placed on a location without a thermoblock or an adapter.
96-well PCR plates, unskirted	Manual placement on the thermoblock. The gripper transports the plate with the thermoblock.	Manual placement is possible. The gripper cannot grip the plates on the adapter. Adapters are not transported.	They cannot be placed on the worktable. The plate cannot be placed on a location without a thermoblock or an adapter.

7.2.2 Deepwell plates

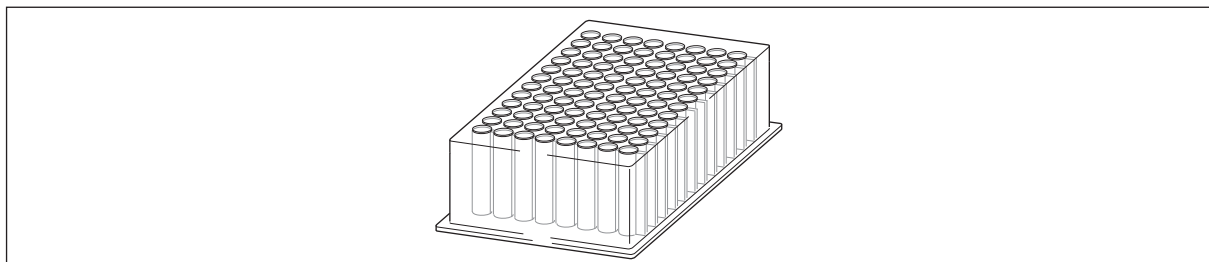

Fig. 7-4: Deepwell plate with 96 wells

You can place the plates directly on a worktable location. You can place the plates on suitable adapters.

A maximum of 2 Eppendorf deepwell plates can be stacked on one location.

For Eppendorf Deepwell Plates 96/1000 µL a thermoadapter is available. For Eppendorf Deepwell Plates 96/2000 µL a thermoblock is available.

7.2.3 Microplates

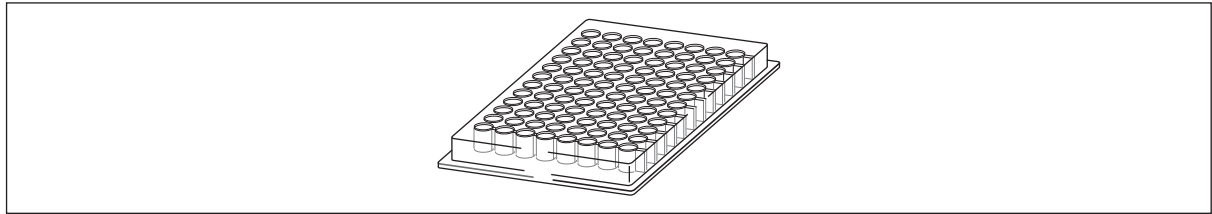

Fig. 7-5: Microplate with 96 wells

You can place the plates directly on a worktable location. You can place the plates on suitable adapters.

A maximum of 5 Eppendorf microplates can be stacked on one location.

Level measurement using the optical sensor is not possible for microplates with 384 wells. Level measurement using the optical sensor is not recommended for microplates with 96 wells.

7.2.4 Tube plates

Tube plates are plates with individual tubes. Tube plates are available in various tube layouts. Tube plates are treated like normal plates.

7.3 Reservoirs

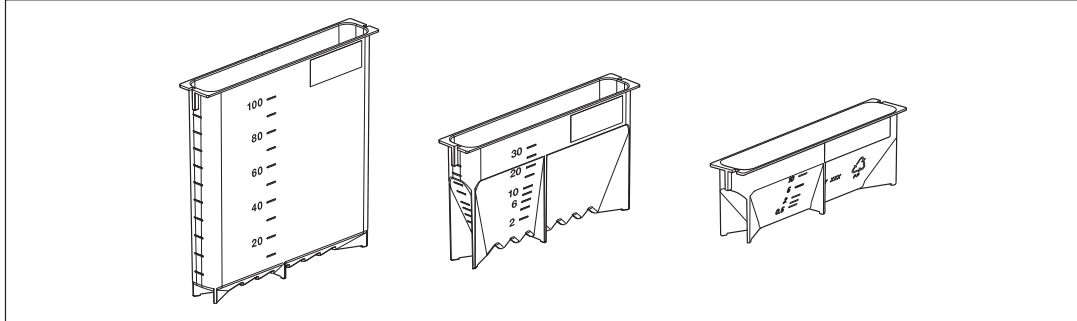

Fig. 7-6: 100 mL, 30 mL and 10 mL reservoirs

Reservoirs make liquids available. Reservoirs are made of polypropylene (PP).

Reservoirs are available in the following sizes:

- 10 mL
- 30 mL
- 100 mL
- 400 mL

7.3.1 Reservoir 10 mL

The 10 mL reservoir can be used with all pipette tips.

The 10 mL reservoir has a smooth base.

Pipette tips of 1000 μL in size cannot be immersed all the way down to the vessel base. A higher remaining volume stays in the reservoir.

The 10 mL reservoir can be tempered if it was inserted into the ReservoirRack with the ReservoirRack module TC 10 mL.

7.3.2 Reservoir 30 mL

The 30 mL reservoir can be used with all pipette tips.

The 30 mL reservoir has a ribbed base. If the bottom tolerance has been reduced, the information on the remaining volume is not accurate.

The 30 mL reservoir is very narrow at the bottom. If the bottom tolerance is reduced, the reservoir can be lifted using the pipette tips.

The 30 mL reservoir is particularly suitable for eight-channel dispensing tools.

The reservoir 30 mL can be tempered if it was inserted into the ReservoirRack with the ReservoirRack module TC 30 mL.

7.3.3 Reservoir 100 mL

The 100 mL reservoir has a ribbed base. If the bottom tolerance has been reduced, the information on the remaining volume is not accurate.

The 100 mL reservoir is particularly suitable for eight-channel dispensing tools.

The TM 50-8 and TM 300-8 eight-channel dispensing tools cannot be immersed all the way down to the base of the vessel. A higher remaining volume stays in the reservoir.

The reservoir 100 mL can be tempered if it was inserted into the ReservoirRack with the ReservoirRack module TC 100 mL.

7.3.4 Reservoir 400 mL

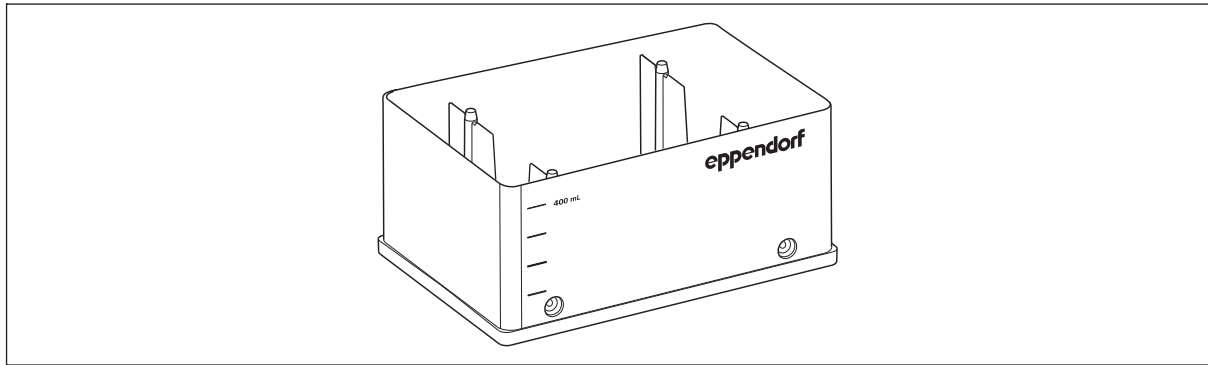

Fig. 7-7: Reservoir 400 mL

The remaining volume of the 400 mL reservoir is approx. 10 mL.

7.4 epT.I.P.S. Motion



NOTICE! Dispensing errors due to incorrect handling of pipette tips.

Pipette tips become deformed and change size during autoclaving.

- ▶ Do not autoclave the pipette tips. If necessary, use pipette tips that are specified as sterile.



Observe the instructions for use for the epT.I.P.S. Motion Racks and epT.I.P.S. Motion Reloads.

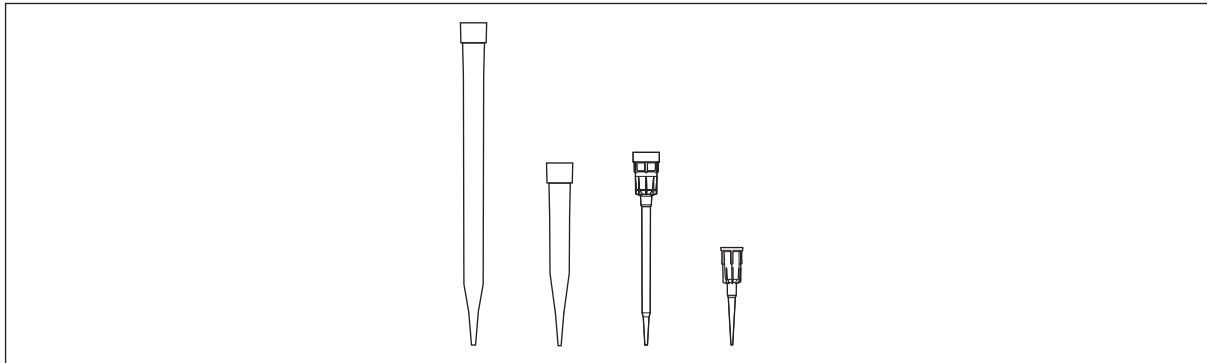

Fig. 7-8: epT.I.P.S. Motion 1 000 µL, 300 µL, 50 µL, 10 µL

epT.I.P.S. Motion are pipette tips for use in the epMotion.

The pipette tips are located in trays. Trays can be part of racks and SafeRacks or they are available separately as reloads. The trays of the reloads are placed on a TipHolder.

Pipette tips, racks and trays are made of polypropylene (PP). The filter of the pipette tips and the protective film of the racks are made of polyethylene (PE).

The trays have a coding. The optical sensor detects the size of the pipette tips from the coding. The optical sensor also detects if the pipette tips have a filter. However, the optical sensor does not detect if the pipette tips are in racks, SafeRacks or in the TipHolder.

Racks, SafeRacks and Reloads must be placed with the bottom side down during storage. This ensures that the pipette tips are hanging in the trays.

Placement

Pipette tips can be positioned on all locations of the epMotion worktable except location B0 and the Eppendorf ThermoMixer module. When racks, SafeRacks and reloads are placed in Row C, the dispensing tool cannot remove any pipette tips.

7.4.1 epT.I.P.S. Motion Racks

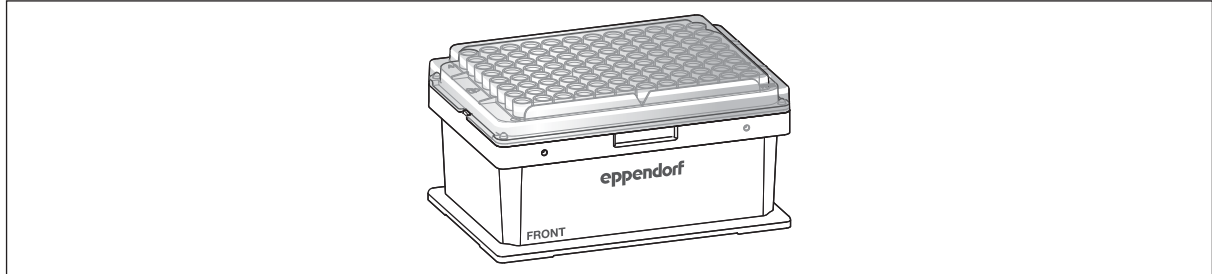

Fig. 7-9: epT.I.P.S. Motion rack

epT.I.P.S. Motion racks are intended for applications in which pipette tips are used only once.

Tab. 7-3: epT.I.P.S. Motion racks are available in the following sizes:

Size of the pipette tips	Dispensing tool	Rack color
10 µL	TS 10, TM 10-8	Dark gray
50 µL	TS 50, TM 50-8	Light gray
300 µL	TS 300, TM 300-8	Yellow
1000 µL	TS 1000, TM 1000-8	Dark blue

Tab. 7-4: epT.I.P.S. Motion racks are available in the following purity grades:

epT.I.P.S. Motion racks	Purity grade
Pipette tips with filter	PCR clean PCR clean and sterile
Pipette tips without filter	Eppendorf Quality Sterile

7.4.2 epT.I.P.S. Motion SafeRacks

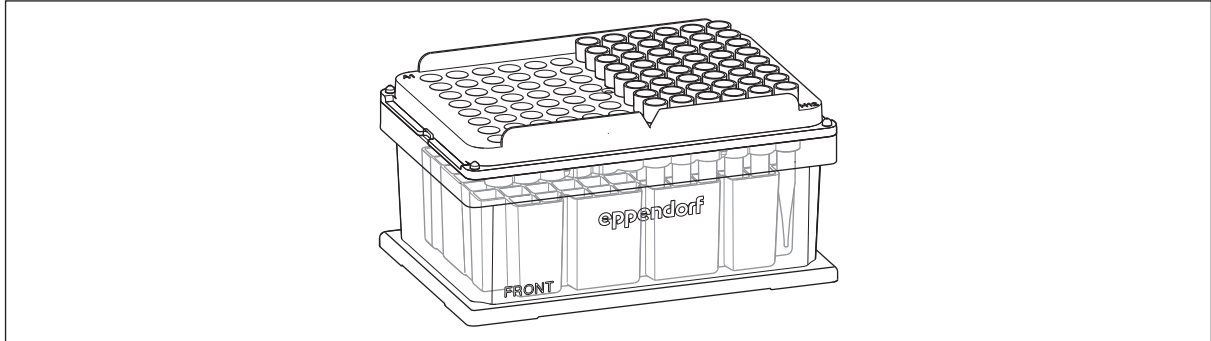

Fig. 7-10: epT.I.P.S. Motion SafeRack



NOTICE! Contamination due to using incorrect pipette tips.

The optical sensor does not detect if the pipette tips on the worktable are intended for single use (epT.I.P.S. Motion Rack, epT.I.P.S. Motion Reload) or multiple use (epT.I.P.S. Motion SafeRack).

- ▶ If the pipette tips will be used several times, equip the entire worktable with epT.I.P.S. Motion SafeRacks.

epT.I.P.S. Motion SafeRacks are suitable for applications in which pipette tips are used multiple times. Example: Aspiration of buffers in several washing steps.

epT.I.P.S. Motion SafeRacks have a partition to separate the pipette tips. During an application, used pipette tips are returned to the SafeRack. The partition prevents the contamination of adjacent pipette tips with residual liquid.

To prevent the contamination of samples due to the repeated use of pipette tips, the software assigns each pipette tip to a defined source position.

In the software, you can set whether pipette tips should be used multiple times (refer to the epMotion software manual).



Use epT.I.P.S. Motion SafeRacks for a maximum of 6 usage cycles. A usage cycle consists of aspiration, dispensing and ejecting the tip.

Tab. 7-5: epT.I.P.S. Motion SafeRacks are available in the following sizes:

Size of the pipette tips	Dispensing tool	Rack color
50 µL	TS 50, TM 50-8	Light gray
300 µL	TS 300, TM 300-8	Yellow
1000 µL	TS 1000, TM 1000-8	Dark blue

Tab. 7-6: epT.I.P.S. Motion SafeRacks are available in the following purity grades:

epT.I.P.S. Motion SafeRacks	Purity grade
Pipette tips with filter	PCR clean
Pipette tips without filter	Eppendorf Quality

7.4.3 epT.I.P.S. Motion reloads

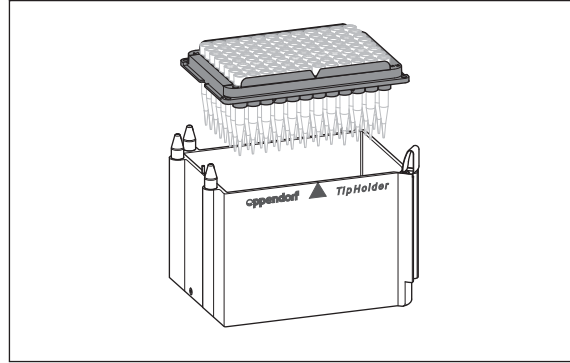
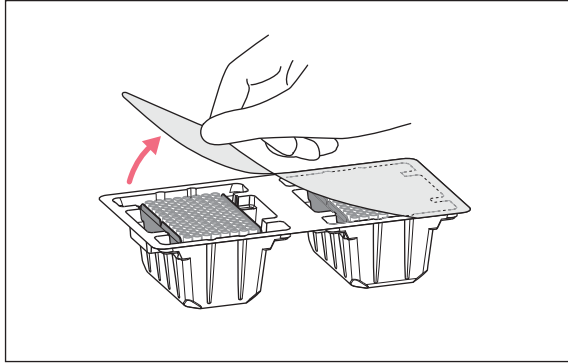

Fig. 7-11: epT.I.P.S. Motion reloads with packing

Fig. 7-12: epT.I.P.S. Motion reloads and TipHolder

epT.I.P.S. Motion reloads consist of a tray which contains 96 pipette tips of the epT.I.P.S. Motion type. epT.I.P.S. Motion reloads are intended for single use.

The trays are placed in reusable TipHolder. This reduces waste as no racks are required.

Tab. 7-7: epT.I.P.S. Motion Reloads are available in the following sizes:

Size of the pipette tips	Dispensing tool	Color of the tray
10 µL	TS 10, TM 10-8	Dark gray
50 µL	TS 50, TM 50-8	Light gray
300 µL	TS 300, TM 300-8	Yellow
1000 µL	TS 1000, TM 1000-8	Dark blue

Tab. 7-8: epT.I.P.S. Motion reloads are available in the following purity grades:

epT.I.P.S. Motion reloads	Purity grade
Pipette tips with filter	PCR clean PCR clean and sterile
Pipette tips without filter	Eppendorf Quality

7.4.4 TipHolder for epT.I.P.S. Motion reloads

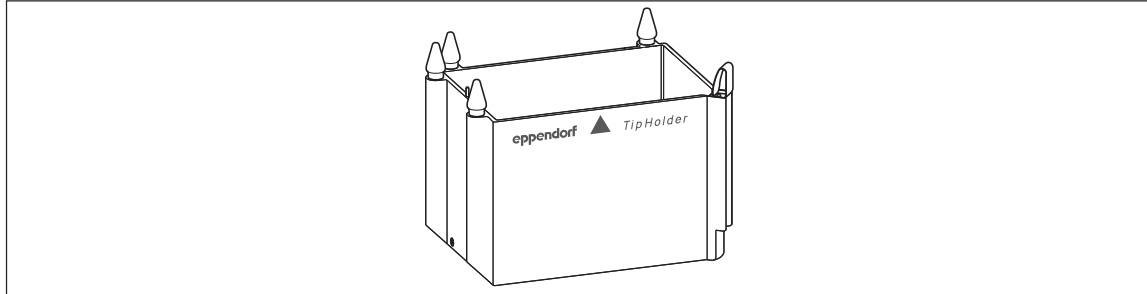

Fig. 7-13: TipHolder

The TipHolder is an adapter that holds epT.I.P.S. Motion reloads.

7.4.4.1 Placing the epT.I.P.S. Motion reloads on the TipHolder

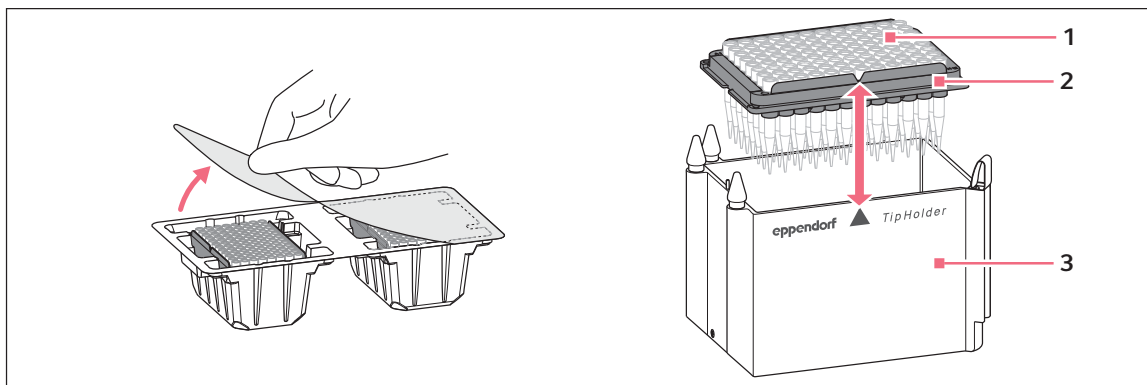

Fig. 7-14: Placing the tray on the TipHolder

1 Tips

2 Tray

3 TipHolder

Prerequisites

- The pipette tips are not damaged.
1. Check that boxes that are used multiple times are undamaged and do not show any signs of abrasion.
 2. Place the tray on a box of the corresponding size. The notch in the tray must be on the labeled side of the box.
 3. Use a clip for trays with 1000 μL pipette tips. Place the clip on the tray from above. Bend the 4 tabs at the corners so that they grip around the tray. The tray is protected against lifting.
- i** When using clips, do not stack the boxes.
4. Place the box on an epMotion worktable location with the label facing the front.

8 Labware accessories



Tubes and accessories may not exceed an overall height of 147 mm. If this height is exceeded, epBlue generates an error message.

8.1 Tip Tool

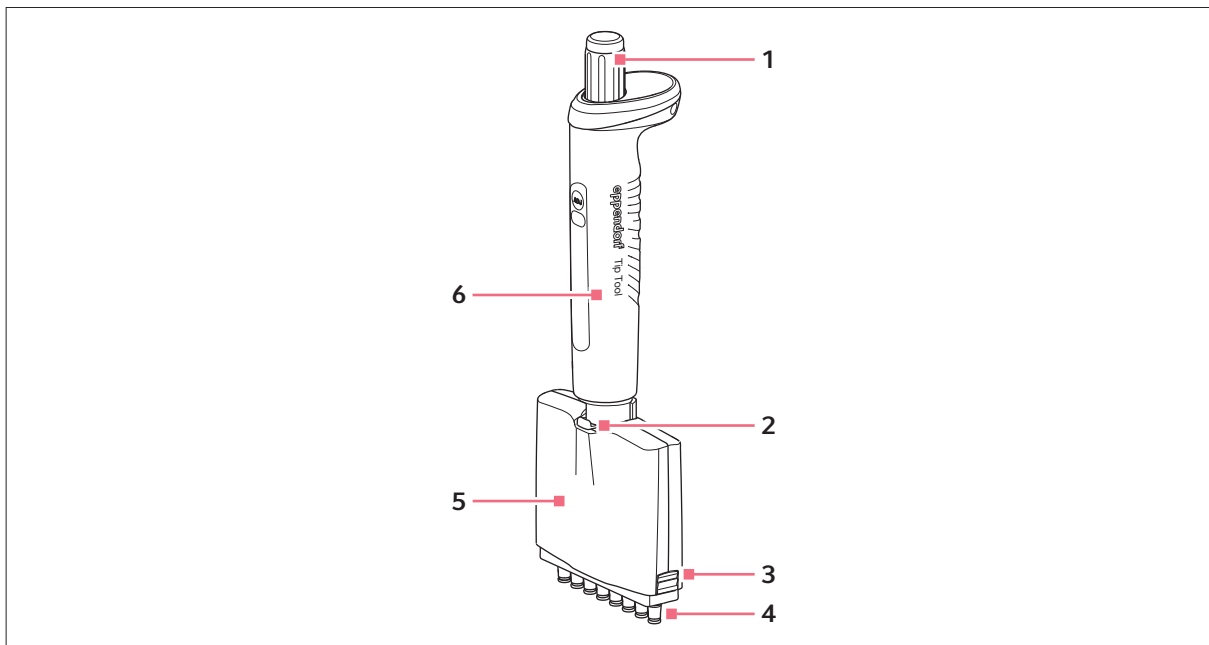

Fig. 8-1: Tip Tool

- | | |
|---|---------------------|
| 1 Ejector
Ejecting the pipette tips | 4 Tip cones |
| 2 Lever
Removing the lower part | 5 Lower part |
| 3 Latch
Unlocking the cover plate | 6 Upper part |

The tip tool is an auxiliary equipment used for equipping the ReservoirRack module tips with empty and unused epT.I.P.S. Motion of 10 µL, 50 µL, 300 µL and 1 000 µL sizes. The tip tool can hold a row (8 pcs.) of epT.I.P.S. Motion.

To keep the tool safe and ready for use, the holder 2 can be attached to the outside of the epMotion on the left or on the right.

8.1.1 Picking up the pipette tips

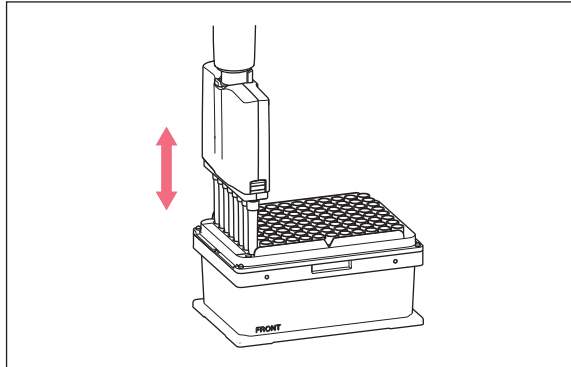

1. Push the tip tool onto the pipette tips vertically from above applying a slight pressure.
2. Use the tip tool to remove the attached pipette tips in an upward motion.

3. Use the tip tool to remove the attached pipette tips in an upward motion.

8.1.2 Ejecting the pipette tips

1. Insert the tip tool with the attached epT.I.P.S. into the corresponding locations of the ReservoirRack module.
2. Press the ejector button.

The epT.I.P.S. Motion are ejected into the corresponding locations.

8.2 Racks

Racks are holders for individual vessels.

8.2.1 Rack for 24 vessels

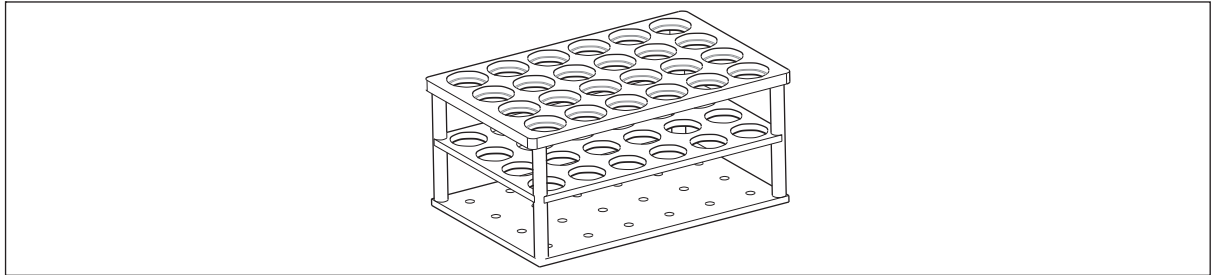

Fig. 8-2: Rack for 24 vessels

Various racks are available for vessels with a diameter of 12 mm – 17 mm. Racks are available in 2 heights. The bores for the vessels are numbered.

The racks cover the same area as plates. Racks can be positioned on any location.

Racks are coded. The optical sensor uses the code to detect if the rack is placed correctly.

8.2.2 Rack for 96 conical vessels

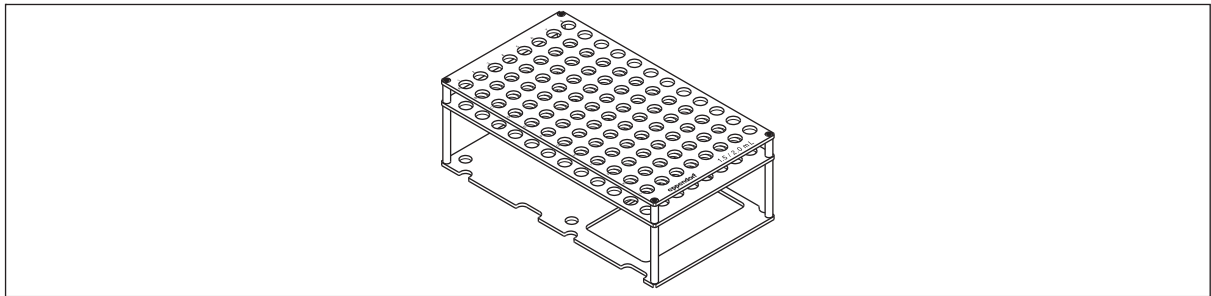

Fig. 8-3: Rack for 96 conical vessels

The rack for 96 conical vessels occupies 2 locations on the worktable.

The rack holds 96 vessels without lids with a volume of 1.5 mL or 2 mL. The rack holds 48 vessels with fastened lids, e.g. Safe-Lock tubes.

8.2.2.1 Equipping the rack

- ▶ If you equip the rack with vessels which have fastened lids, leave every other row of the rack empty.
- ▶ Check that the lids do not cover the openings of adjacent vessels.

8.2.2.2 Place the rack on the worktable

1. Place the rack on the epMotion worktable so that the opening in the lower panel points towards the user.
2. Place the rack on the positioning pins of the two locations.

8.2.3 Rack 0.5/1.5/2.0 mL

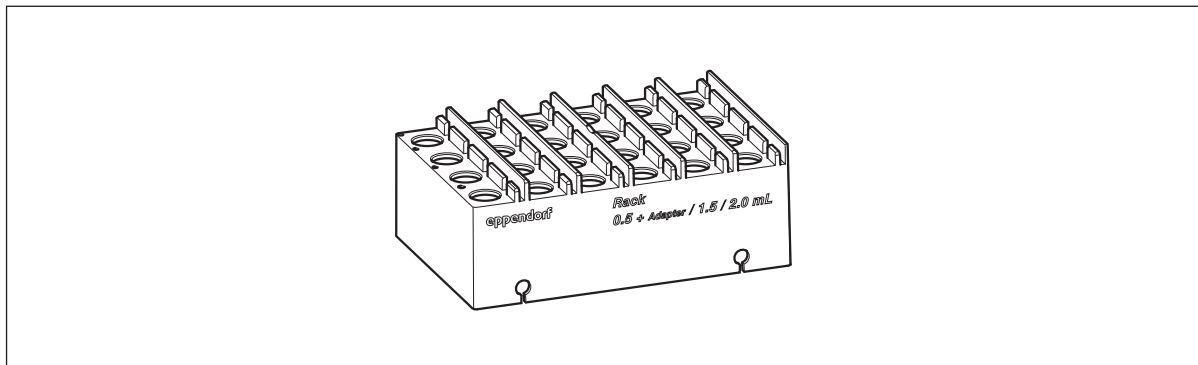

Fig. 8-4: Rack 0.5/1.5/2.0 mL

The Rack 0.5/1.5/2.0 mL has 24 bores for vessels with a volume of 1.5 mL and 2 mL. If you are using adapters, vessels with a volume of 0.5 mL can be used.

The Rack 0.5/1.5/2.0 mL has lid holders. The lid holders are on the right, next to the bore for the vessel. The lid holders clamp the tube lid vertically.

8.2.4 Rack LC

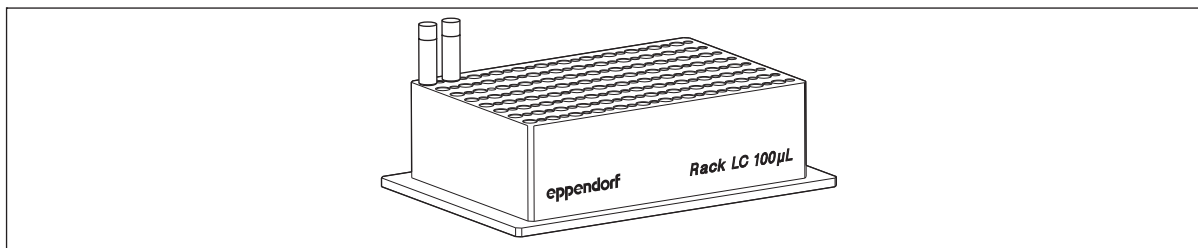

Fig. 8-5: Rack LC 100 µL

The Rack LC holds the following capillaries:

- 96 LightCycler capillaries with a volume of 20 µL
- 96 LightCycler capillaries with a volume of 1000 µL

The Rack LC has bores for each capillary size. The bores are arranged in an alternating pattern.

The Rack LC is labeled on both of the longer sides. One side is labeled Rack LC 20 µL, the other side is labeled Rack LC 100 µL.

8.2.4.1 Equipping Rack LC

- ▶ Equip the Rack LC. Only use capillaries of one size for the same application.

8.2.5 Rack for ILMN tubes

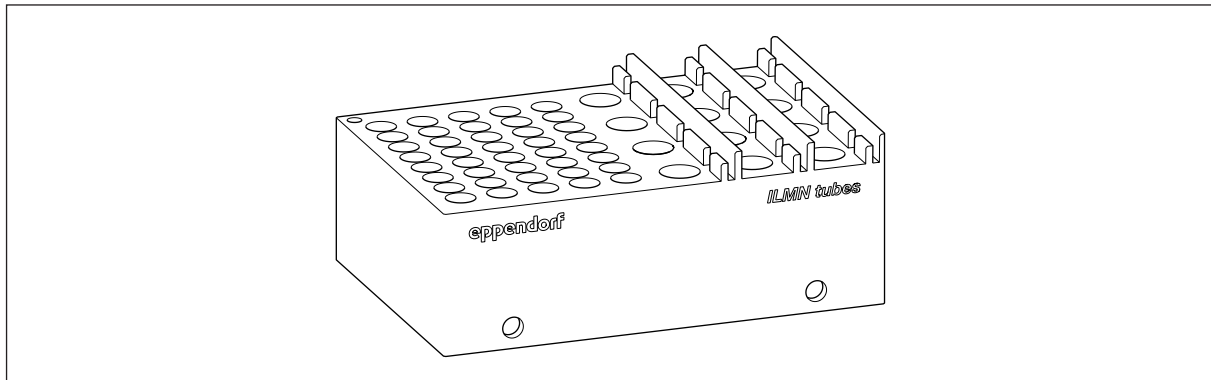

Fig. 8-6: Rack for ILMN tubes

The rack holds vessels of different sizes. In columns 1 – 5, 40 tubes with a diameter of 8.4 mm can be placed, e.g. Illumina Index tubes i5/i7 or 1.10 mL Tubes Internal Thread by Micronic. In columns 6 – 8, 12 tubes with a diameter of 11.2 mm can be placed, e.g. Eppendorf Safe-Lock Tubes 1.5 mL and 2 mL.

8.2.6 Thermorack 0.5/1.5/2.0 mL

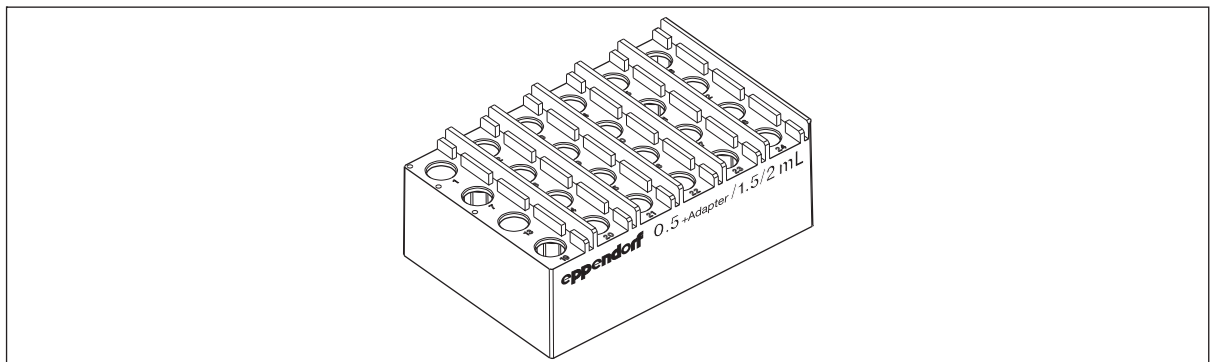

Fig. 8-7: Thermorack 0.5/1.5/2.0 mL

The Thermorack 0.5/1.5/2.0 mL has 24 bores for vessels with a volume of 1.5 mL and 2 mL. If you are using adapters, vessels with a volume of 0.5 mL can be used.

The Thermorack 0.5/1.5/2.0 mL has lid holders. The lid holders are on the right, next to the bore for the vessel. The lid holders clamp the tube lid vertically.

Thermoracks can be cooled in the lab refrigerator.

8.2.7 Thermorack Rotor/Tubes

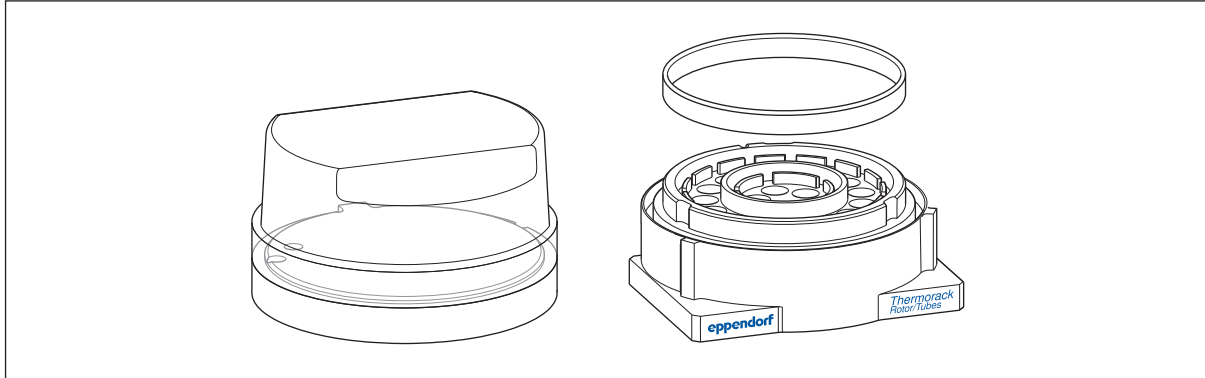

Fig. 8-8: Thermorack rotor/tubes

The Thermorack Rotor/Tubes can be tempered on a thermal module in the epMotion. The Thermorack Rotor/Tubes reduces the time it takes the samples to reach the target temperature.

The epMotion can fill the tubes on the Thermorack Rotor/Tubes with sample material and extract sample material from the tubes. The epMotion fills the locations of the Qiagen Rotor-Disc with sample material. The epMotion cannot extract sample material from the locations of the Qiagen Rotor-Disc.



The epMotion 5070 cannot reach positions E2 to E8 of the Qiagen rotor disc 72 and positions D10 to E8 of the Qiagen rotor disc 100.

The following labware can be used in the Thermorack Rotor/Tubes:

- a Qiagen Rotor-Disc 72 or a Qiagen Rotor-Disc 100
- in addition a maximum of 20 Eppendorf micro test tubes 1.5 mL/2.0 mL or a maximum of 20 Sarstedt screw cap tubes 1.5 mL

The Qiagen Rotor-Disc can be cooled in the lab refrigerator.

The delivery package includes a ring. The ring fixes the Thermorack Rotor/Tubes on the Thermorack Rotor/Tubes.

A lid and an adapter for putting the lid on are available for the Thermorack Rotor/Tubes.

On the epMotion 5070 the lid and the adapter cannot be placed on the worktable.

8.2.7.1 Placing the Thermorack Rotor/Tubes on the worktable

The Thermorack Rotor/Tubes takes up 2 locations on the worktable. The location directly behind the thermorack cannot be equipped with labware.

1. Place the equipped Thermorack Rotor/Tubes in a location in the following row:
 - Row B
2. Place the ring onto the Qiagen Rotor-Disc.

8.2.8 ReservoirRack

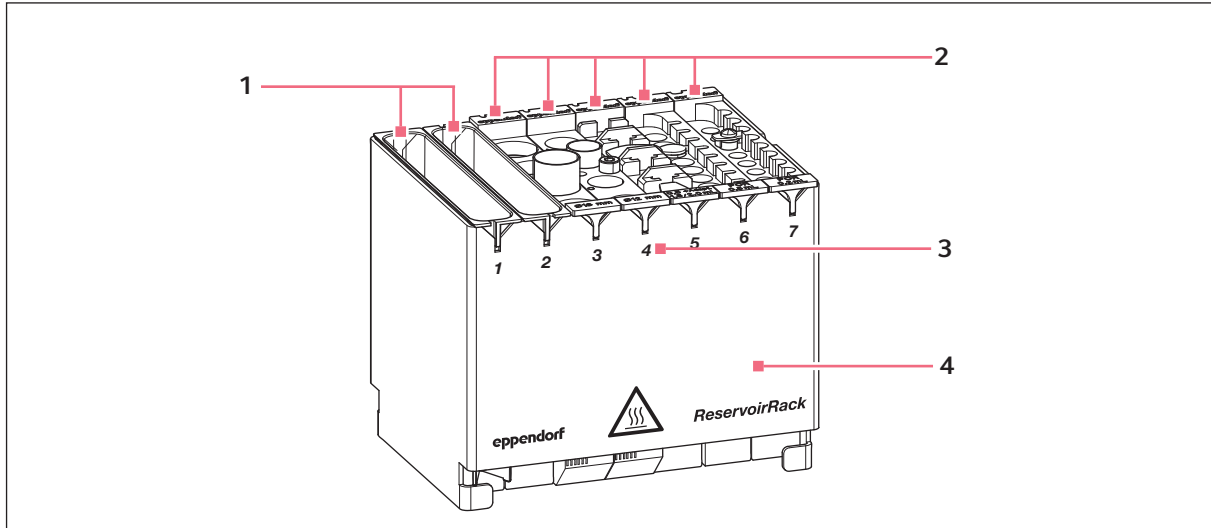

Fig. 8-9: Equipped ReservoirRack

- | | |
|------------------------|-------------------------|
| 1 Reservoir | 3 ReservoirRack columns |
| 2 ReservoirRack module | 4 ReservoirRack |

The ReservoirRack is used for locating reservoirs and ReservoirRack modules. The ReservoirRack columns are numbered.

The ReservoirRack module holds a maximum of 7 reservoirs or 7 different ReservoirRack modules. ReservoirRacks can be equipped in any order.

8.2.8.1 Equipping ReservoirRacks

Location 1 and location 7 are not tempered as well as the other locations of the ReservoirRack.

- ▶ Place ReservoirRack modules in the ReservoirRack with the code facing the rear.
- ▶ Insert the reservoirs into the ReservoirRack facing any direction.

8.2.8.2 Placing the ReservoirRack on the worktable

- ▶ The ReservoirRack cannot be placed on locations A1 or A2.
- ▶ Place the ReservoirRack on the worktable so that the ReservoirRack tabs are located between the positioning pins of the location.

8.2.9 ReservoirRack modules

ReservoirRack modules TC

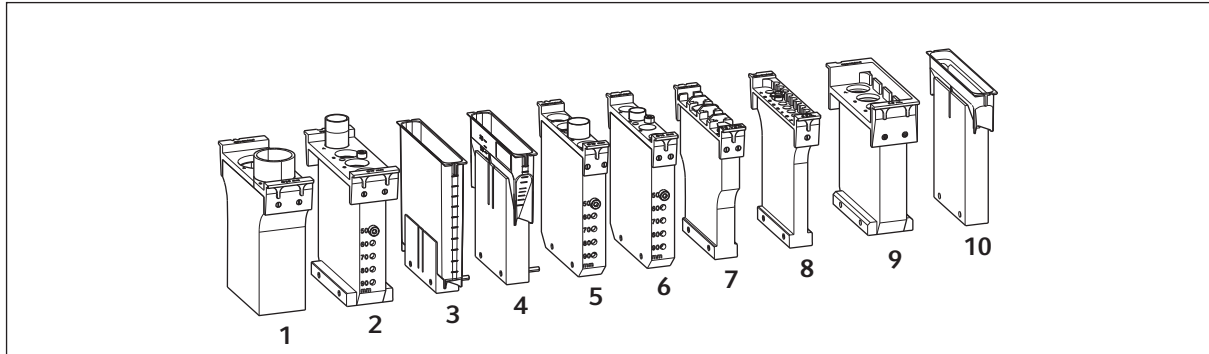

Fig. 8-10: ReservoirRack modules TC

- | | |
|---|--|
| <p>1 ReservoirRack module TC
for two 29 mm Ø micro test tubes</p> <p>2 ReservoirRack module TC
for four 17 mm Ø micro test tubes</p> <p>3 ReservoirRack module TC
for one 100 mL reservoir</p> <p>4 ReservoirRack module TC
for one 30 mL reservoir</p> <p>5 ReservoirRack module TC
for four 16 mm Ø micro test tubes</p> | <p>6 ReservoirRack module TC
for four 12 mm Ø micro test tubes</p> <p>7 ReservoirRack module TC
for four 1.5 mL/2 mL Safe-Lock tubes / 0.5 mL with adapter</p> <p>8 ReservoirRack module TC
for eight 0.2 mL PCR tubes</p> <p>9 ReservoirRack module TC
for four 5 mL Eppendorf Tubes</p> <p>10 ReservoirRack module TC
for one 10 mL reservoir</p> |
|---|--|

A ReservoirRack module is equipped with vessels or a reservoir. All of the vessels inserted into a ReservoirRack module must be of the same type. The ReservoirRack module is inserted into a ReservoirRack.

The TC ReservoirRack modules are temperature-controlled.

Temperature control of the micro test tubes

Micro test tube	Temperature control from 23 °C to 4 °C		Temperature control from 23 °C to 37 °C	
	Set temperature	Temperature control duration	Set temperature	Temperature control duration
0.2 mL PCR tube	3 °C	approx. 15 min	38 °C	approx. 8 min
0.5 mL Safe-Lock tube	3 °C	approx. 20 min	38 °C	approx. 12 min
Safe-Lock tube 1.5 mL	2 °C	approx. 20 min	38 °C	approx. 12 min
Safe-Lock tube 2.0 mL	3 °C	approx. 20 min	38 °C	approx. 12 min
12 mm Ø micro test tube	3 °C	approx. 30 min	38 °C	approx. 17 min
16 mm Ø micro test tube	3 °C	approx. 30 min	38 °C	approx. 17 min
5 mL tube	3 °C	approx. 30 min	38 °C	approx. 17 min
15 mL conical tube	2 °C	approx. 30 min	38 °C	approx. 17 min
50 mL conical tube	3 °C	approx. 39 min	39 °C	approx. 23 min
Reservoir 10 mL	1 °C	approx. 30 min	39 °C	approx. 30 min
Reservoir 30 mL	1 °C	approx. 21 min	39 °C	approx. 15 min
Reservoir 100 mL	1 °C	approx. 46 min	40 °C	approx. 28 min

This table shows the time it takes to reach the set temperature if the user has entered the set temperature in the software.

ReservoirRack modules PCR

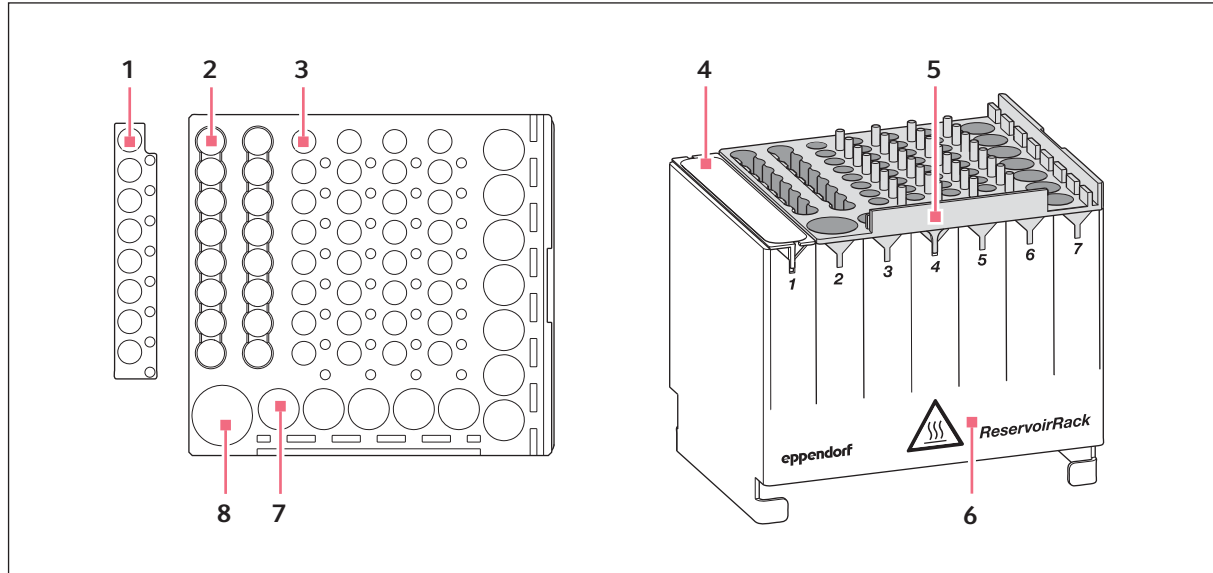

Fig. 8-11: ReservoirRack module PCR

- | | |
|---|---|
| 1 Locations for 0.2 mL PCR tubes | 5 ReservoirRack module PCR |
| 2 Locations for 1.0 mL ILMN tubes | 6 ReservoirRack |
| 3 Locations for 0.2 mL PCR tubes or PCR strips | 7 Locations for 0.5/1.5/2.0 mL micro test tubes |
| 4 Reservoir optional | 8 Location for 5 mL micro test tube with screw cap |

A ReservoirRack module PCR can take up locations 2–7 of a ReservoirRack and must be positioned in a way that the lettering faces the user. The optical sensor can measure the filling level of the inserted tubes. The code on the labware cannot be scanned. A ReservoirRack module PCR can hold the following tubes:

- One 5 mL micro test tube with screw cap
- 12 1.5/2.0 mL micro test tubes / 0.5 mL micro test tubes with adapters
- 32 0.2 mL PCR tubes (4 PCR strips)
- 16 0.2 mL PCR tubes or 1.0 mL ILMN tubes

ReservoirRack modules PCR are autoclavable.

ReservoirRack modules NGS

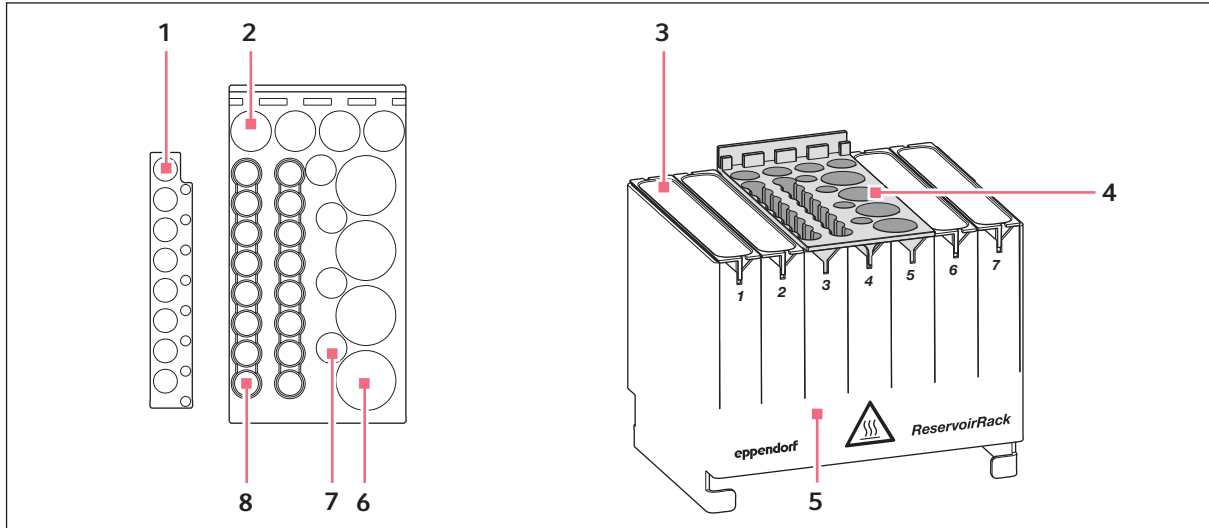

Fig. 8-12: ReservoirRack module NGS

- | | |
|--|--|
| 1 Locations for 0.2 mL PCR tubes | 5 ReservoirRack |
| 2 Locations for 0.5/1.5/2.0 mL micro test tubes | 6 Locations for 5 mL micro test tubes with screw caps |
| 3 Reservoir optional | 7 Locations for 1.0 mL ILMN tubes |
| 4 ReservoirRack module NGS | 8 Locations for 1.0 mL ILMN tubes |

A ReservoirRack module NGS can take up 3 locations of a ReservoirRack and must be positioned so that the lettering faces the user. Location 7 must not be occupied by a ReservoirRack module NGS. The optical sensor can measure the filling level of the inserted tubes. The code on the labware cannot be scanned. The ReservoirRack module NGS can hold the following tubes:

- Four 5 mL micro test tubes
- Four 1.5/2.0 mL micro test tubes / 0.5 mL micro test tubes with adapters
- Four 1 mL ILMN micro test tubes
- 16 0.2 mL PCR tubes or 1.0 mL ILMN tubes

ReservoirRack modules NGS are autoclavable.

ReservoirRack module Tips

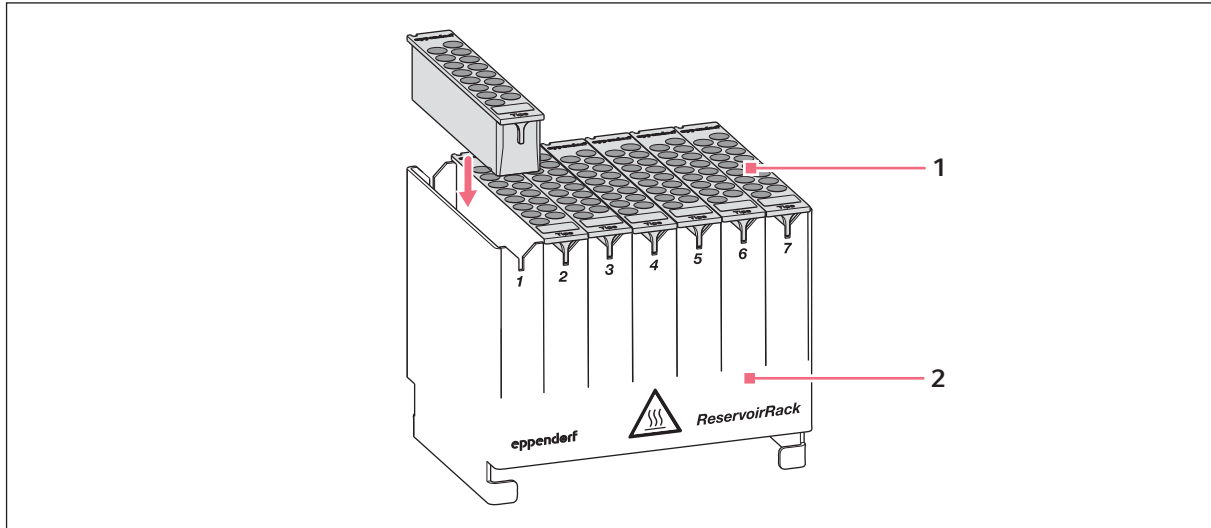

Fig. 8-13: ReservoirRack module Tips

1 ReservoirRack module Tips

2 ReservoirRack

ReservoirRack module tips can hold 16 identical epT.I.P.S. Motion. ReservoirRack modules Tips are available for all sizes of epT.I.P.S. Motion. A ReservoirRack can be filled with ReservoirRack modules Tips equipped with different types.

ReservoirRack modules Tips are autoclavable.

8.2.9.1 Inserting the strip adapter

The strip adapter can be inserted into the ReservoirRack modules NGS and PCR to provide more locations for 0.2 mL PCR tubes.

The strip adapter is autoclavable.

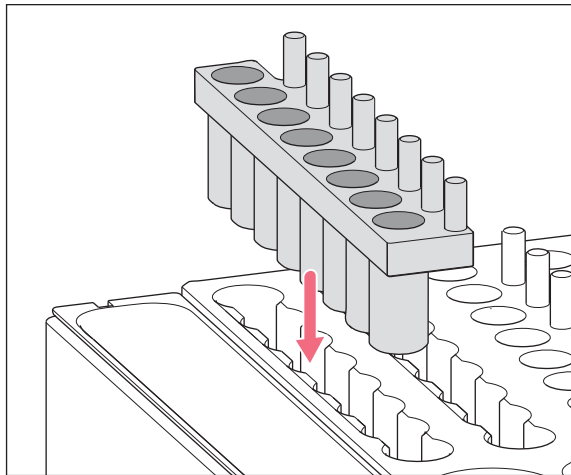

1. Ensure that the locations of the ILMN tubes are not occupied.
2. The strip adapter has a notch on its bottom side to ensure correct positioning in the ReservoirRack module. Insert the strip adapter into the locations of the ILMN tubes so that the notch is at the front and the pins are on the right (see image).

Fig. 8-14: Strip adapter

8.2.9.2 Connecting the ReservoirRack module with the adjacent module

The ReservoirRack modules for the 10 mL, 30 mL and 100 mL reservoirs cannot be placed separately in the ReservoirRack. The ReservoirRack modules must be joined with the adjacent ReservoirRack module.

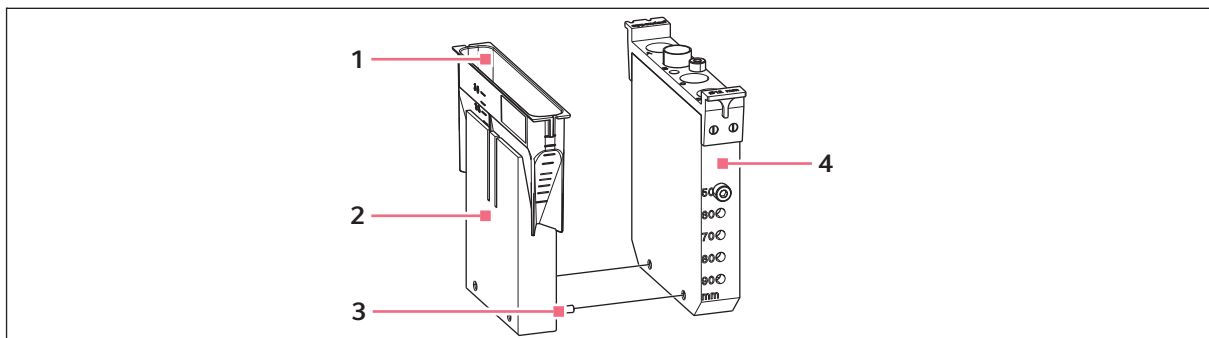

Fig. 8-15: Join the ReservoirRack module TC for the 30 mL reservoir with the adjacent module.

- | | |
|---|--|
| <p>1 30 mL reservoir</p> <p>2 ReservoirRack modules TC for 30 mL reservoirs</p> | <p>3 Connecting bar</p> <p>4 Adjacent module</p> |
|---|--|

There are 2 connecting bars on one side of the ReservoirRack modules for the 10 mL, 30 mL and 100 mL reservoirs.

- ▶ Insert the 2 connecting bars into the adjacent ReservoirRack module.

8.2.9.3 Adjusting the height of the vessels

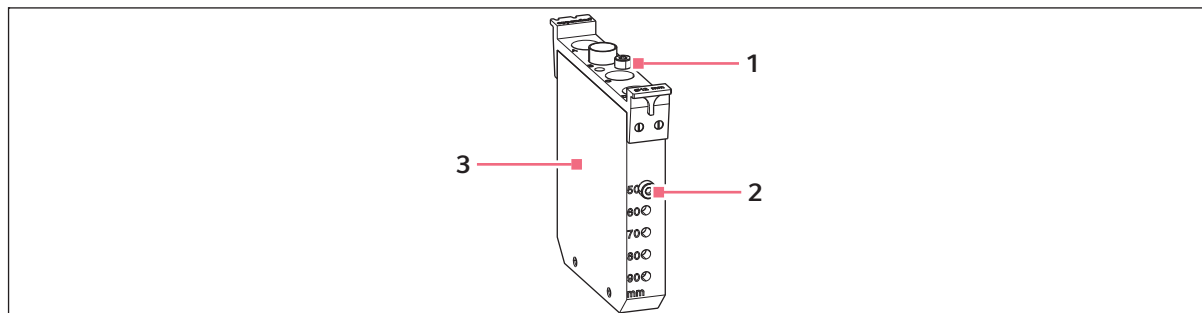

Fig. 8-16: Setting the ReservoirRack module to vessel height

1 Positioning screw

in resting position

3 ReservoirRack module

2 Positioning screw

at height of 50 mm

You can place tubes with a height of 50 mm, 60 mm, 70 mm, 80 mm and 90 mm in any ReservoirRack module. There is one bore at the front and one at the rear of the ReservoirRack module at each of these heights.

- ▶ Screw the two positioning screws into the bores at the required height.

8.3 Adapter

The following adapters are available for the epMotion:

- Height adapter
- Thermodapter
- Magnetic adapter
- Vacuum holder

8.3.1 Height adapter

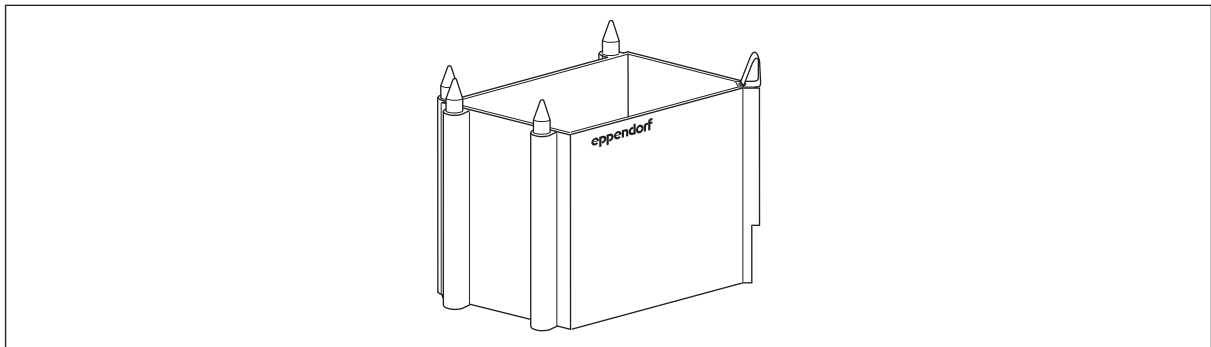

Fig. 8-17: Height adapter

Height adapters are used to compensate the different heights of the labware. The tool holder does not need to compensate the height differences of the labware and remains at one height. The shorter paths of this tool holder enable the application to run more quickly.

The height of the adapter is listed on the adapter. The total height of adapter and labware must not be more than 147 mm.

Tab. 8-1: Available height adapters

Adapter	Use with
40 mm	<ul style="list-style-type: none"> • epT.I.P.S. Motionracks with a size of 50 µL and 300 µL
55 mm	<ul style="list-style-type: none"> • DWP plates • Reservoir 400 mL • Thermoblock with PCR plate
85 mm	<ul style="list-style-type: none"> • Virtually all MTP plates with 6 – 384 wells • Virtually all PCR plates with 96 – 384 wells • Thermoblock für PCR plates with PCR plate

8.3.2 Thermoadapter for PCR plates and deepwell plates

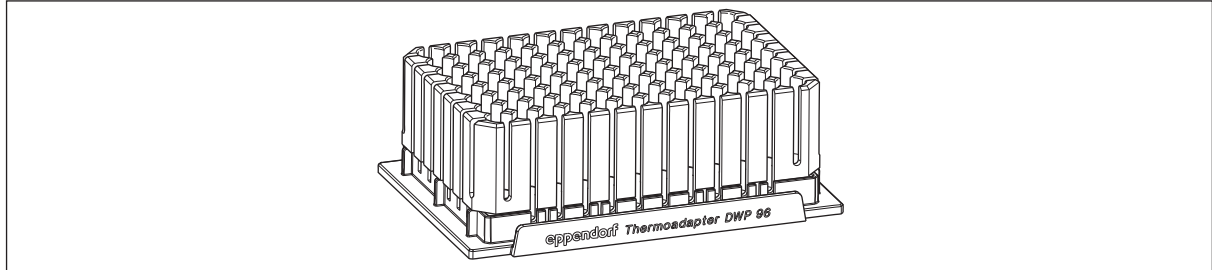

Fig. 8-18: Thermoadapter DWP 96

Thermoadapters are temperature-controlled adapters.

Thermoadapters can be placed on the worktable with or without plates.

For PCR plates and deepwell plates the following thermoadapters are available:

- for PCR plates, 96 wells, skirted
- for PCR plates, 384 wells, skirted
- for Eppendorf Deepwell Plates 96/1000 μ L

8.3.3 Thermoadapter LC Samples

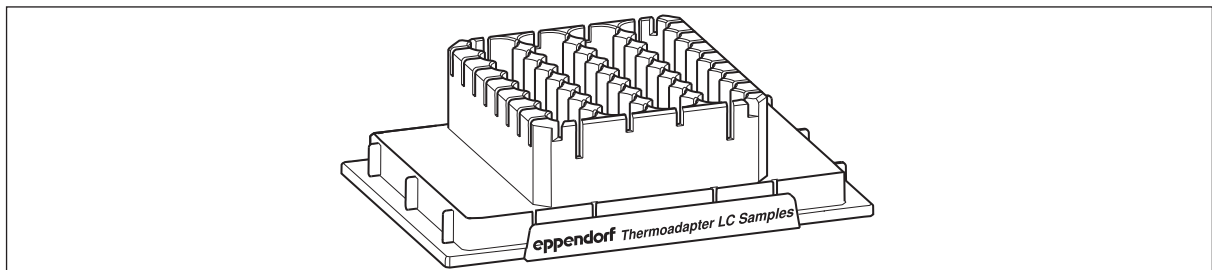

Fig. 8-19: Thermoadapter LC Samples

The thermoadapter LC Samples is a tube holder for the automatic filling of MagNA Pure LC Sample Cartridges. Thermoadapters and cartridges are a fixed combination for the epMotion.

The thermoadapter LC Samples can be temperature controlled up to 70°C.

8.3.4 Thermoadapter Microplate 96/V/U

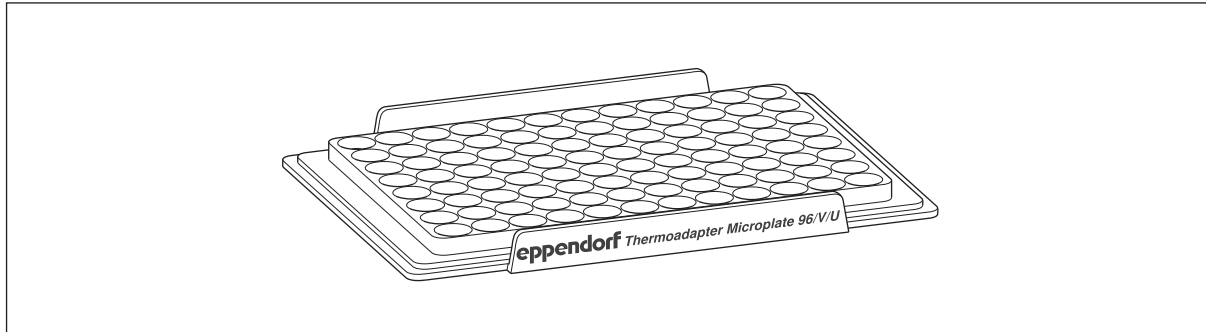

Fig. 8-20: Thermoadapter Microplate 96/V/U

The thermoadapter Microplate 96/V/U is not permanently attached to a plate.

The following labware can be inserted into the thermoadapter Microplate 96/V/U:

- Microplate 96/V
- Microplate 96/U

8.3.5 Thermoadapter Frosty

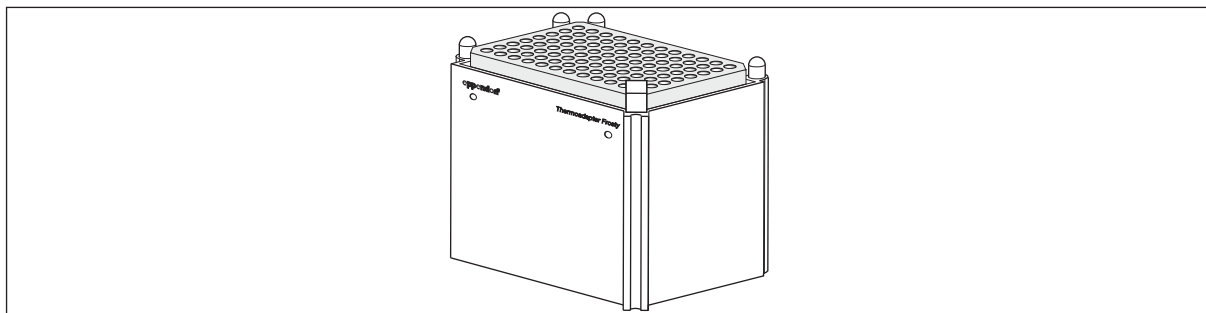

Fig. 8-21: Thermoadapter Frosty

The Thermoadapter Frosty cools samples.

The Thermoadapter Frosty is a modified height adapter. The Thermoadapter Frosty includes a PCR-Cooler. A PCR plate is placed on the Thermoadapter Frosty. The PCR-Cooler cools the samples in this plate. The Thermoadapter Frosty can only be used with skirted PCR plates.

8.3.5.1 Preparing the Thermoadapter Frosty

1. Cool the PCR-Cooler. To do this, place the PCR-Cooler upside down into the lab refrigerator or into the ultra-low temperature upright freezer at -20 °C.
2. Insert the PCR-Cooler into the Thermoadapter Frosty.
3. Place a PCR plate on the Thermoadapter Frosty.



The PCR-Cooler changes color if the temperature exceeds 7°C. The color changes from violet to pink or from dark blue to light blue. The color in the recesses of the PCR-Cooler is the decisive factor for the temperature of the samples.

8.3.6 Magnum FLX magnetic adapter 96-well plates



WARNING! Strong magnetic field on Magnum FLX magnetic adapter 96-well plates

Magnetic fields affect the function of pacemakers and defibrillators.

- ▶ If you have a pacemaker or defibrillator, avoid any contact with the Magnum FLX magnetic adapter 96-well plates.



WARNING! Risk of crushing due to strong magnetic field

Each Magnum FLX magnetic adapter 96-well plates has a strong magnetic field. If the distance between the magnetic adapter and other magnetizable materials is <10 cm they will attract each other very quickly and very strongly. They are then very difficult to separate. Any limbs caught between the magnets may get seriously injured.

Examples for magnetizable materials: other magnetic adapters, steel surfaces, other magnets.

- ▶ Make sure that there is a minimum distance of 10 cm between the magnetic adapter and the tool holder, carrier and rear panel of the device.
- ▶ Only use the magnetic adapter as described in the instructions for use.



CAUTION! Skin irritation from nickel

The magnets of the Magnum FLX magnetic adapter 96-well plates are plated with Ni-Cu-Ni. Ni-Cu-Ni can trigger an irritation of the skin.

- ▶ If you are allergic or sensitive to nickel, avoid contact with the Magnum FLX magnetic adapter 96-well plates.
- ▶ Wash irritated skin with soap and water.
- ▶ Contact a physician, if required.



NOTICE! Material damage due to magnetic field

Media which contain magnets may get damaged if they are near the magnetic adapter. Examples: computers, CRT-based monitors, credit cards.

- ▶ Prevent the Magnum FLX magnetic adapter 96-well plates from coming near metal objects or other magnets.

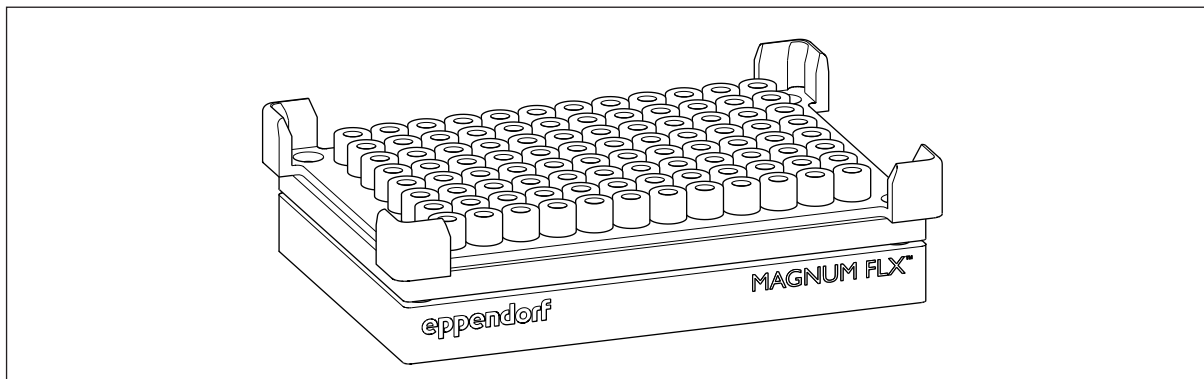

Fig. 8-22: Magnum FLX magnetic adapter 96-well plates

The Magnum FLX magnetic adapter 96-well plates is used for the quick and efficient settling of magnetic particles from liquid columns up to a height of 40 mm. It can be used for working volumes of >10 µL.

The Magnum FLX magnetic adapter 96-well plates is a ring magnet plate. The Magnum FLX magnetic adapter 96-well plates is used to isolate magnetic beads in a suspension and to remove washing liquid.

Labware containing a bead suspension is placed on the magnetic adapter. The magnetic adapter has 96 strong ring magnets. The ring magnets cause the beads to settle on the tube inner wall after an incubation period. The beads form a ring at magnet level. The sample supernatant is aspirated below the bead ring using a pipette tip without aspirating the beads.

The following plates can be inserted in the Magnum FLX magnetic adapter 96-well plates:

- Standard plates
- Deepwell plates
- Plates with round bottoms and V-bottoms
- PCR plates (skirted, semi-skirted, unskirted)



If warped labware is placed on the magnetic adapter, the magnetic beads may end up on the magnetic adapter.

The Magnum FLX magnetic adapter 96-well plates must not be tempered.

The gripper is not used to transport the Magnum FLX magnetic adapter 96-well plates. Any plates on the magnetic adapter are transported using the gripper.

8.4 Thermoblock

A thermoblock is a temperature-controlled adapter into which plates are inserted. The thermoblock is transported by the gripper.

There are two types of thermoblocks for epBlue:

- *Thermoblocks*: Thermoblock and labware are available as separate labware definitions.
- *Thermoblocks with Plates*: Thermoblock and labware are combined in a labware definition. The thermoblock is not available as a separate labware definition.

Store the thermoblock in the laboratory refrigerator to cool it.

8.4.1 Thermoblock PCR 96

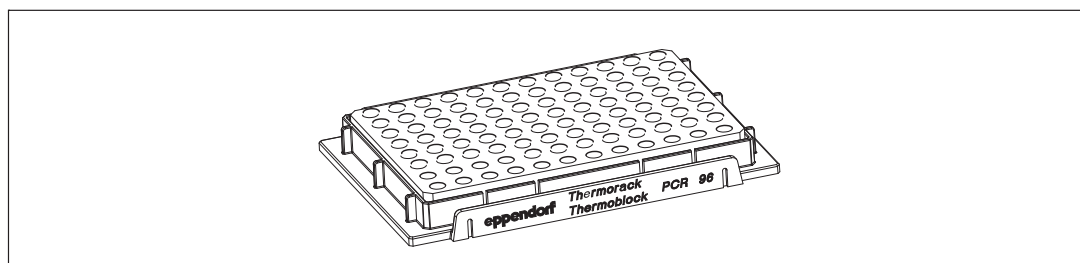

Fig. 8-23: Thermoblock PCR 96

96 micro test tubes 0.2 mL, PCR tubes 0.5 mL or a 96-well PCR plate of the semi-skirted type can be inserted in the Thermoblock PCR 96.

In epBlue, thermoblock and labware are combined. The thermoblock is not available as a separate labware definition.

Thermoblock	Plate firmly connected to the thermoblock	Filling volume per tube	Temperature control duration from 0 °C to 10 °C
PCR 96	96-well twin.tec PCR plate	150 µL	~ 14 min

8.4.1.1 Equipping the Thermoblock PCR 96 with 0.2 mL tubes

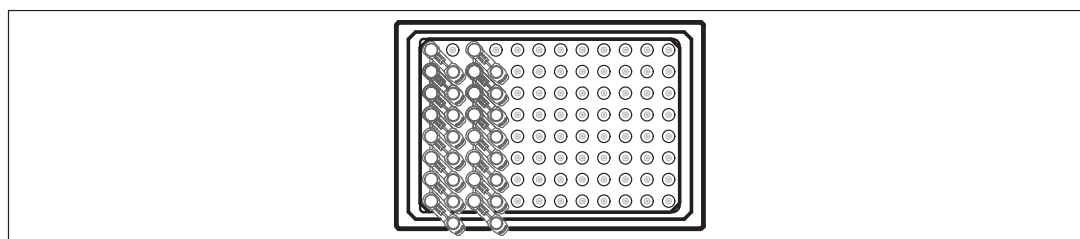

Fig. 8-24: Tube lid rotated 45° to the surface of the thermoblock

- ▶ Position the tubes in columns. Leave every other column empty for the tube lids.
A maximum of 48 micro test tubes with lids can be positioned in the thermoblock.

8.4.2 Thermoblock PCR 96 OC

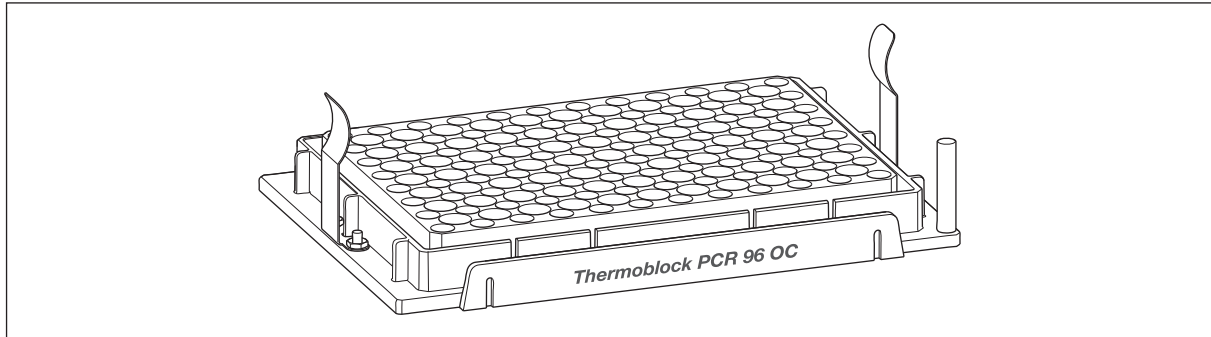

Fig. 8-25: Thermoblock PCR 96 OC

The Thermoblock PCR 96 OC (OC = Orientation Control) has been developed to open sealed plates safely. They can be opened safely by piercing the seal with a pipette tip. Clamps prevent the plate from being lifted by the retracting pipette tips. You can find information on the parameters for opening sealed plates in the software manual.

Plates of the semi-skirted type which have a cut-away corner on the bottom right can be inserted in the Thermoblock PCR 96 OC.

In epBlue the Thermoblock PCR 96 OC is not combined permanently with a labware. The thermoblock is available as a separate labware definition.

The Thermoblock PCR 96 OC facilitates working with sealed plates where the labeling is not legible. The Thermoblock PCR 96 OC has a pin on the bottom right for this purpose. Plates must be inserted in such a way that their cut-away corner is also on the bottom right. This ensures that location A1 of the plate is located on the top left.

The Thermoblock PCR 96 OC is suitable for high rotational speeds. The maximum rotational speed is 1700 rpm.

Labware	Recommended maximum speed in rpm	Maximum quantity of sample material
Thermoblock PCR 96 OC	1600	With an unsealed plate <140 µL

8.4.2.1 Positioning the plate on the Thermoblock PCR 96 OC

Prerequisites

- A semi-skirted type plate with a cut-away corner

1. Check whether the clamps on the Thermoblock PCR 96 OC are bent.
2. If the clamps are bent, replace the clamps. Use spare clamps.
3. Place the semi-skirted type plate on the thermoblock. Insert the plate so that the cut-away corner is on the bottom right.
4. Check whether the plate is positioned correctly in the thermoblock.
 - The plate is held firmly by the clamps.
 - The plate is firmly seated in the bores of the thermoblock.

8.4.3 Thermoblock PCR 384

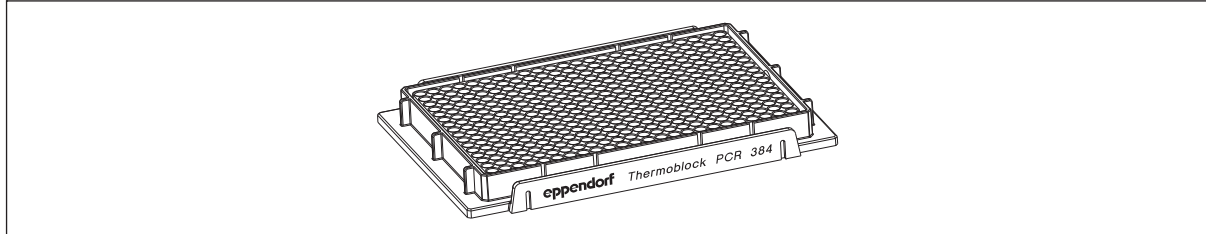

Fig. 8-26: Thermoblock PCR 384

384-well twin.tec PCR plates of the semi-skirted type can be inserted in the Thermoblock PCR 384.

In epBlue, thermoblock and labware are combined. The thermoblock is not available as a separate labware definition.

Thermoblock	Plate firmly connected to the thermoblock	Filling volume per tube	Temperature control duration from 0 °C to 10 °C
PCR 384	384-well twin.tec PCR plate	25 µL	~ 10 min

8.4.4 Thermoblock DWP 2000

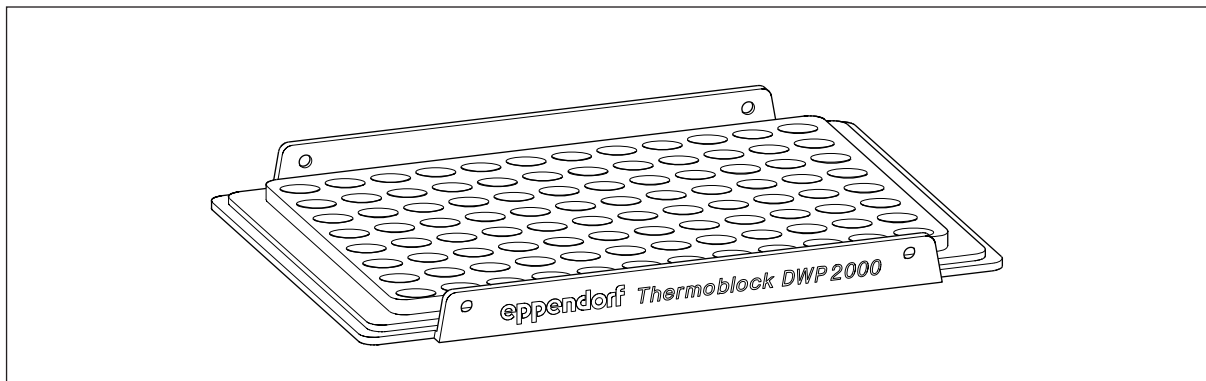

Fig. 8-27: Thermoblock DWP 2000

You can insert the thermoblock DWP 2000 in Eppendorf Deepwell Plates 96/2000 µL.

In epBlue, the thermoblock is not combined permanently with a labware. The thermoblock is available as a separate labware definition.

8.4.5 Comparing thermoblocks and thermoadapters

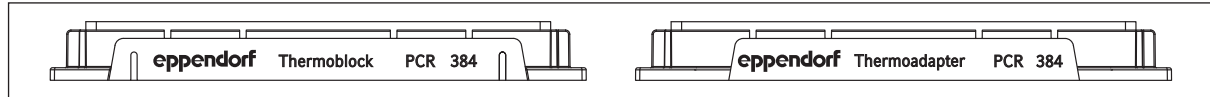

Fig. 8-28: Comparing thermoblocks and thermoadapters

For some plates, thermoblocks and thermoadapters are available, e.g. for 384 well-PCR plates.

Thermoblocks and thermoadapters are labeled on their sides. The labeling includes the name of the manufacturer, the type of the adapter and the name of the compatible labware.

Thermoadapters and thermoblocks also have different bar lengths. Thermoadapters have shorter bars than thermoblocks.

Thermoblocks feature gripping grooves for the gripper.

8.5 Waste container



NOTICE! NOTICE! Risk of contamination from waste materials.

If the waste container is full and more labware is discarded, the labware can fall onto the worktable and contaminate it.

- ▶ Check how much waste will be created with your application and empty the waste container via User Intervention, if necessary.
- ▶ Ensure that the waste container is empty when starting an application.

8.5.1 Waste box

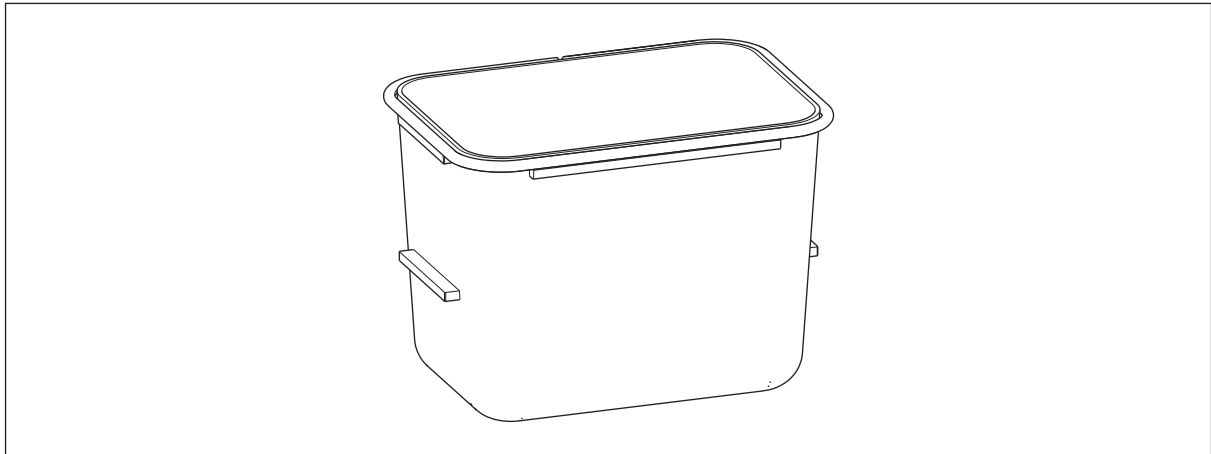

Fig. 8-29: Waste box with the ferrule attached

The waste box is a vessel for holding used pipette tips in the *epMotion*. You can insert a waste bag and a LiquidWasteTub in the waste box.

8.5.1.1 Placing the waste bag in the waste box

Use a waste bag to protect the waste box from contamination.

Prerequisites

- Waste bag
- Ferrule

1. Place the waste bag in the waste box.
2. Use the ferrule to fasten the waste bag.
3. Pull the edge of the waste bag down tight.

8.5.2 Waste bag holder

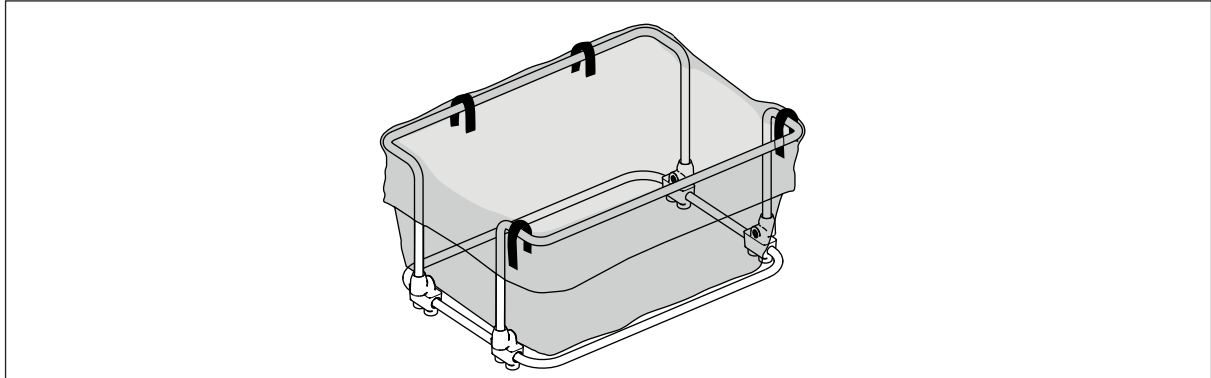

Fig. 8-30: Holder with waste bag

The waste bag holder is a rack for attaching a waste bag. You can insert a LiquidWasteTub in the holder.

8.5.2.1 Inserting the waste bag into the holder



NOTICE! Risk of collision due to loose waste bag.

If the waste bag protrudes into adjacent locations on the *epMotion* worktable, the waste bag can get caught on the gripper or the dispensing tool. The waste bag can be pulled from the holder.

- ▶ Use the clamps to attach the waste bag to the holder.
- ▶ Arrange the waste bag so that it does not protrude into the adjacent locations of the worktable.

Prerequisites

- Waste bag

1. Pull the waste bag over the holder.
2. Fold back the waste bag. The fold must reach the base of the holder.
3. Pull the edge of the waste bag down tight.
4. Use 4 clamps to fix the waste bag. Attach 2 clamps to the side of the holder that faces the rear panel.
Insert the waste bag so that it does not protrude into the adjacent locations of the *epMotion* worktable.

8.5.3 LiquidWasteTub



WARNING! Danger due to contamination of the LiquidWasteTub.

The outer surface of the LiquidWasteTub may become contaminated by pipette tips in the waste container.

- ▶ Wear your personal protective equipment.
- ▶ Decontaminate the outer surface of the LiquidWasteTub.

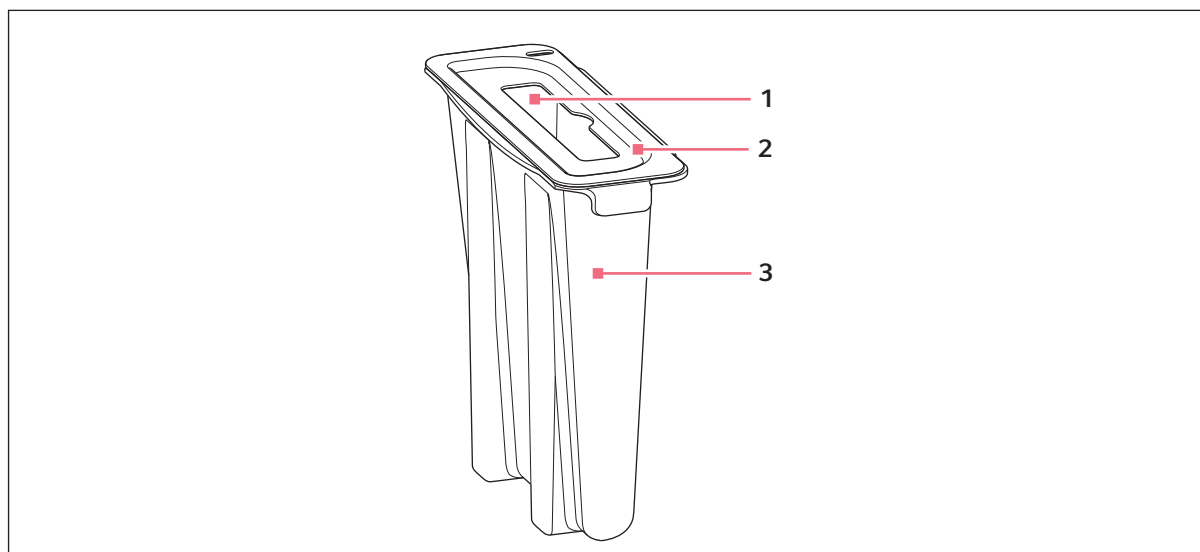

Fig. 8-31: LiquidWasteTub with lid

1 Opening for dispensing tool

3 LiquidWasteTub

2 Lid

The LiquidWasteTub is a container for liquid waste and is hung inside the waste box or from the waste bag holder. LiquidWasteTubs are available with a working volume of 400 mL.

The lid of the LiquidWasteTub prevents contamination caused by splashes from the liquid waste.

The LiquidWasteTub is reusable. You can decontaminate and clean the LiquidWasteTub (see *Decontamination and cleaning on p. 111*).

The optical sensor does not detect whether there is a LiquidWasteTub on the worktable. The optical sensor does not detect the size, the working volume and the filling level of a LiquidWasteTub.

You need to define in the software with which LiquidWasteTub the waste container is equipped.

8.5.3.1 Inserting the LiquidWasteTub into a waste container



NOTICE! Risk of collision due to loose LiquidWasteTub.

If the LiquidWasteTub is not seated properly in the waste container, the dispensing tool may collide with the LiquidWasteTub when the pipette tips are ejected.

- ▶ Always use the waste container with the ferrule.

You can insert the LiquidWasteTub into the waste box and into the waste bag holder.

1. If necessary, insert the waste bag into the waste container.

2. Place the LiquidWasteTub on the edge of the waste container.

The tabs of the LiquidWasteTub must protrude over the ferrule of the waste box.

3. If necessary, put the lid on the LiquidWasteTub.

4. Place the waste container on the worktable.

The LiquidWasteTub must be located on the right-hand side of the waste container.

8.5.4 Waste bag



WARNING! Danger due to flammable and infectious liquids in the waste container and waste bags.

Pipette tips in the waste container and in waste bags may contain flammable or infectious liquids.

- ▶ Wear your personal protective equipment.
- ▶ Handle the pipette tips and sample material from the waste container and waste bags in accordance with the safety data sheets, safety regulations and laboratory guidelines.
- ▶ Dispose of the pipette tips and sample material from the waste container and waste bags in accordance with the safety data sheets, safety regulations and laboratory guidelines.

Waste bags are used for holding and for the disposal of used pipette tips in the epMotion. Eppendorf AG offers waste bags for standard applications and waste bags for hazardous materials.

Waste bags can be inserted in the waste box or in the waste bag holder.

Properties of the waste bag

- Size 345 mm × 350 mm
- Thickness 50 µm
- Transparent
- Autoclavable
- Heat resistant to 134 °C
- Tested for leak tightness

8.5.4.1 Disposal of the waste bag

1. Remove the waste bag from the device and seal lightly.
2. Autoclave the waste bag.
The waste bag must not be tightly sealed during autoclaving.
3. Dispose of the waste bag in accordance with laboratory regulations.

9 Operation

9.1 First steps

9.1.1 Switching on the epMotion

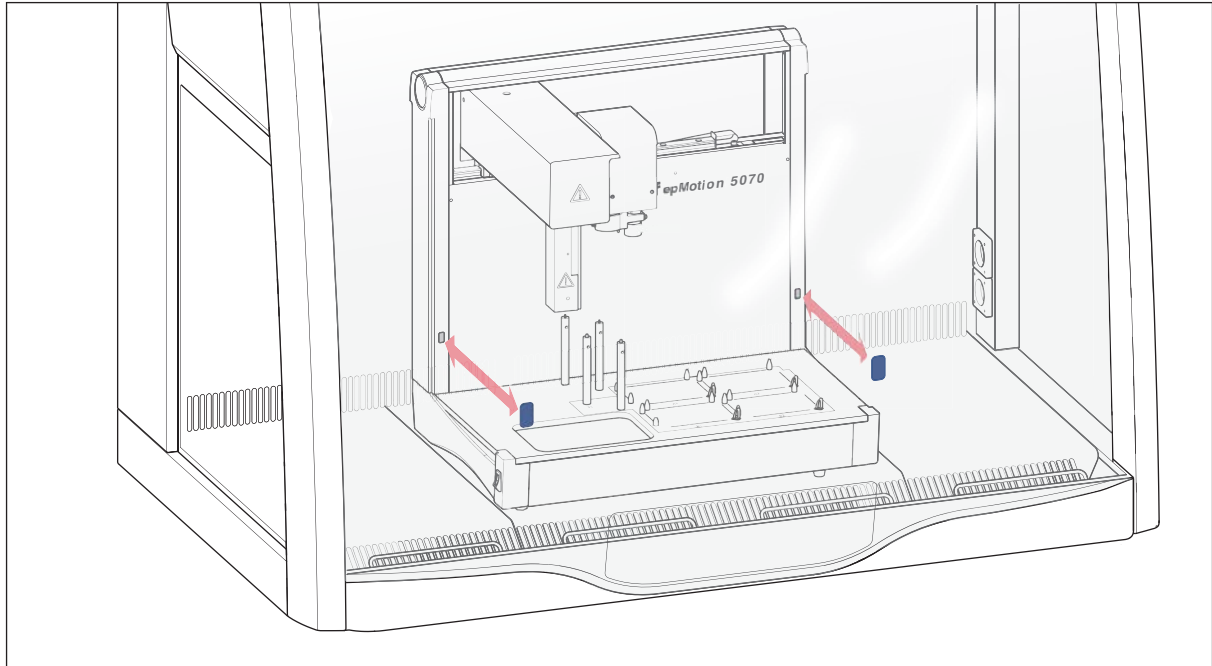

Fig. 9-1: epMotion in a cleanbench

Prerequisites

- The epMotion has been installed and commissioned by service technicians who are authorized by Eppendorf.
1. Close the front hood.
 2. If you use an epMotion in a Cleanbench, put the front panel of the Cleanbench in the operating position. The light barrier will build up.
 3. Switch on the epMotion at the mains/power switch. The carrier travels to the starting position.
 4. Switch on the MultiCon PC and start epBlue.
 5. The EasyCon tablet starts and displays the start screen.

9.1.2 Operation of the epMotion

You can operate the epMotion via the touch screen or with the USB mouse and USB keyboard.

- ▶ Connect the USB mouse and the USB keyboard to one of the USB ports on the control device.

9.1.3 Backing up data



NOTICE! Data loss and malfunction due to malicious software.

Malicious software, e.g. a computer virus on the USB storage medium may be transferred to the computer.

- ▶ Before connecting the USB storage medium, check the USB storage medium using an up-to-date antivirus software.



NOTICE! Data loss due to missing backup or incorrect storage of data carriers.

User accounts, applications, labware and logs are stored in one database. If this database becomes damaged (e.g. due to a hardware defect), data will be lost. Eppendorf is not liable for the loss of data. Eppendorf is not liable for any damage caused by data loss.

- ▶ Back up the database on a regular basis. Use the *Backup* function of the epBlue software.
- ▶ Save the backed-up data to external data carriers.
- ▶ Store the data carriers according to the manufacturer's instructions.



NOTICE! Malfunction due to third-party software.

Third-party software may impair the function of the epBlue software.

- ▶ Only install software approved by Eppendorf.
-

You need a USB storage medium to transfer or back up data.

1. Connect the USB storage medium to one of the USB ports.
The storage medium is ready for operation after 5 seconds.
2. Execute the required function in the software (refer to the epMotion software manual).

9.1.4 Working with epMotion

The epMotion workflow consists of the following steps.

1. Create the application (refer to the epMotion software manual).
2. Open the application (refer to the epMotion software manual).
3. Place the labware, pipette tips and tools on the epMotion worktable (see p. 103).
4. Prepare the application run (refer to the epMotion software manual).
5. Execute the application (see p. 107).
6. Complete your work (see p. 110).

9.2 Placing tools and labware on the worktable

In order to prepare the *epMotion* for an application, perform the following steps:

- Display the epBlue worktable in the software
- Place the tools
- Place the epT.I.P.S. Motion
- Place the waste container
- Place additional labware

9.2.1 Displaying the epBlue worktable



NOTICE! Collision of tools with incorrectly placed labware.

Labware must be placed on the *epMotion* worktable as defined in the application. Tools and labware will be damaged if there is a collision. A collision can lead to sample loss.

- ▶ Check the placement of the labware before starting the application.

1. Open the application.
2. Place the tools and labware as shown on the *epMotion* worktable.
Details on placement can be found in the following chapters.

9.2.2 Placing dispensing tools on the worktable



NOTICE! Damage to the gold contacts from handling.

If the gold contacts of the tool are damaged or contaminated this will damage the tool.

- ▶ Do not touch the gold contacts.

You can place two dispensing tools on the worktable.

When the application is started, the *epMotion* checks if the required tools are available. The order of the dispensing tools can be selected freely.

- ▶ Place the dispensing tool into the holders T1 to T2 with the gold contact on the right at the rear.

9.2.3 Placing the epT.I.P.S. Motion on the worktable



NOTICE! Dispensing errors due to incorrect handling of pipette tips.

Pipette tips become deformed and change size during autoclaving.

- ▶ Do not autoclave the pipette tips. If necessary, use pipette tips that are specified as sterile.



NOTICE! Incorrect stock detection due to missing pipette tips.

The optical sensor checks the start position and the end position of the pipette tips in the rack. The optical sensor does not check if pipette tips are missing in the center.

- ▶ Do not remove any pipette tips from the rack.



NOTICE! Contamination due to using incorrect pipette tips.

The optical sensor does not detect if the pipette tips on the worktable are intended for single use (epT.I.P.S. Motion Rack, epT.I.P.S. Motion Reload) or multiple use (epT.I.P.S. Motion SafeRack).

- ▶ If the pipette tips will be used several times, equip the entire worktable with epT.I.P.S. Motion SafeRacks.



Observe the instructions for use for the epT.I.P.S. Motion Racks and epT.I.P.S. Motion Reloads.

The optical sensor detects the type of pipette tips using the coding on the tray. The *epMotion* removes the pipette tips from the racks, column by column. For additional information (see p. 67)

1. remove the protective film.
2. If you are using epT.I.P.S. Motion Reloads, place the tray on the TipHolder.
3. Place the rack or TipHolder on the worktable location with the label facing the front.

9.2.4 Placing the waste container on the worktable

1. Insert the waste bag into the holder.
2. If necessary, insert the LiquidWasteTub in the waste container (see p. 99).
3. Insert the waste container in the *epMotion*.

9.2.5 Placing additional labware on the worktable



NOTICE! Collisions or dispensing errors due to uneven or canted labware.

Labware must be level on the worktable.

- ▶ Do not tilt the labware.



NOTICE! Collision with tube lids.

If lids block the tube opening, there is a risk of collision with the dispensing tool.

- ▶ Position the tube lid in such a way that the tube opening is not covered.



NOTICE! Risk of collision when using the 10 µL dispensing tools

The carrier will collide with a dispensing tool in the holder or with the holder under the following conditions:

- **epMotion 5075:** There is a dispensing tool on holder T4.
You are using the TS 10 dispensing tool in location A2.
 - **epMotion 5075:** You are using the TS 10 dispensing tool in location B1.
 - **epMotion 5073:** There is a dispensing tool on holder T2 (<serial number 6000) or T3 (from serial number 6000 onwards).
You are using the TS 10 dispensing tool in location A1.
 - **epMotion 5070:** There is a dispensing tool on holder T2.
You are using the TS 10 or TM 10 dispensing tool in location A1.
- ▶ Do not use the 10 µL dispensing tools in the specified locations.
 - ▶ Alternatively, use the labware in the specified locations with a height adapter.
 - ▶ Alternatively, equip the worktable in such a way that there is no dispensing tool on holder T4 (5075), T2 (5073, 5070) or T3 (5073) while the 10 µL dispensing tool is used in location A2 (5075) or A1 (5073, 5070).
 - ▶ **epMotion 5075** If the TS 10 dispensing tool is used, a height adapter must be used in location B1.

Special details on placement can be found in the Labware chapter (see *Labware accessories on p. 73*).

9.2.5.1 Tubes

1. Open the lids of the tubes.
2. Place the tubes upright in the racks.
Place tubes with lids in racks with lid holders only.
3. Lock any attached lids into place using the lid holders on the rack.

9.2.5.2 ReservoirRack module

- ▶ Place the ReservoirRack module in the ReservoirRack (see p. 79).

9.2.5.3 Plates, racks and adapters

The labware must not have any play on the epMotion worktable location.

1. Align the labware.

- Align the racks and adapters on the epMotion worktable in such a way that the labeling faces the user.
- Align the plates on the epMotion worktable in such a way that location A1 of the plate is located at the rear left.

Plates, racks, epT.I.P.S. Motion racks and thermo adapters

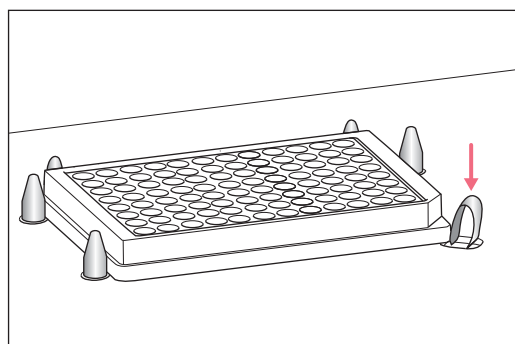

2. Place the labware in such a way that the retention clip pushes the labware against the positioning pins.
3. If necessary, tighten the retention clip by hand. The labware must be in contact with the positioning pins of the location.

Height adapter, TipHolder and ReservoirRack

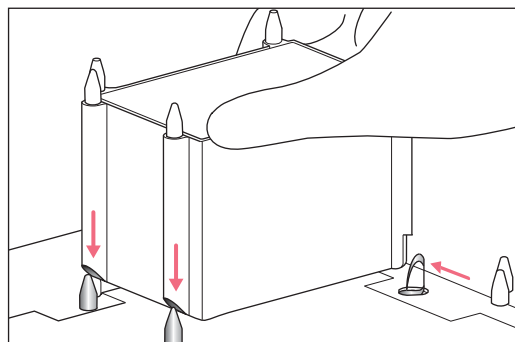

4. Place the height adapter, TipHolder and ReservoirRack over the positioning pins.

9.3 Executing an application



Detailed information on how to execute an application can be found in the software manual.

9.3.1 Performing a test run

Before you execute an application for the first time, carry out a test run.



Carry out the test run with a liquid which has similar physical properties to the liquid that is to be used in the application.

1. Open the application.
2. Fill the labware with defined volumes. Use demineralized water or a test liquid for the test run.
3. Place labware and tools on the epMotion worktable.
4. Prepare the application run (refer to the epMotion software manual).
5. Perform *Surface Teaching* if the following prerequisites are met.
 - You are working with liquid aspiration or liquid dispensing from a defined position.
 - You are pipetting below the bottom tolerance.
 - The pipette tips and labware have production-specific tolerances. If you are using a new batch, perform *Surface Teaching* again.
6. Fully execute the application.
7. Check to see if the application was executed without any errors.
 - Dispensing is precise and correct.
 - No liquid sprays out of the tubes. Contamination is unlikely.

Information on optimizing dispensing can be found in the software manual.

9.3.2 Performing an application run



NOTICE! Incorrect level measurement due to air bubbles.

If there are any air bubbles in the vessels, the optical sensor measures the filling level incorrectly.

- ▶ Check if there are any air bubbles in the vessels before starting the application.
- ▶ Carefully tap the labware on the work surface to remove air bubbles.

Prerequisites

- The epMotion is ready for operation.
- The application is open (refer to the epMotion software manual).
- Labware and tools are placed on the epMotion worktable (see p. 103).
- The application run has been prepared, see epMotion software manual, chapter *Application Runner*.

1. Start the application run.

If you have epBlue with an "Extended functions scope 1" license, you can start the application run at a defined place.

2. Enter the filling volume of the tubes manually, if required.

- The epMotion checks if the required tools are placed on the epMotion worktable.
- The optical sensor checks the labware and filling levels, if required.
- The application is executed. The software displays the status of the application.

9.3.3 Controlling the application run



CAUTION! Risk of injury due to movement of the carrier.

The carrier may still be moving when the front hood of the epMotion is opened.

- ▶ Wait until the carrier is at standstill before reaching into the device.

9.3.3.1 Stopping the application immediately

You can stop the application immediately, e.g. if there is a risk of a collision.

- ▶ Open the front hood.
 - The application run is stopped immediately.
- ▶ If you use an epMotion in a Cleanbench, raise or lower the front panel of the Cleanbench.
 - The front panel of the Cleanbench leaves the operating position. The light barrier is interrupted. The application run is stopped immediately.
- ▶ You can continue or abort the application run.

9.3.3.2 Interrupting the application run

- ▶ Stop the application run using the **||** button (refer to the epMotion software manual).
The current movement will be ended. After that, the application run is stopped.
- ▶ You can continue or abort the application run.

9.3.3.3 Continuing the application run

Prerequisites

- Labware and tools on the epMotion worktable have not been changed.
- The filling volumes of the vessels have not been changed.
- The carrier has not been moved manually.

1. Close the front hood.
2. If you use an epMotion in a Cleanbench, close the front panel of the Cleanbench.
3. Continue the application run with the **▶** button (refer to the epMotion software manual).

9.3.3.4 Aborting the application run



NOTICE! Contamination due to multiple use of pipette tips.

If you abort an application which includes the multiple use of pipette tips, the epT.I.P.S. Motion SafeRacks will contain used pipette tips. The device does not detect which pipette tips have already been used.

- ▶ Dispose of epT.I.P.S. Motion SafeRacks immediately after the application has been aborted.

Prerequisites

- The application run was stopped or interrupted.
- ▶ Abort the application run with the **✘** button (refer to the epMotion software manual).
 - The application run will be aborted.
 - The tool holder returns the tool to its original position.
 - The carrier travels to the starting position.
 - The epMotion is ready for operation.
- ▶ Close the application in the software.

9.4 Completing your work

9.4.1 Cleaning up the worktable



WARNING! Danger due to flammable and infectious liquids in the waste container and waste bags.

Pipette tips in the waste container and in waste bags may contain flammable or infectious liquids.

- ▶ Wear your personal protective equipment.
- ▶ Handle the pipette tips and sample material from the waste container and waste bags in accordance with the safety data sheets, safety regulations and laboratory guidelines.
- ▶ Dispose of the pipette tips and sample material from the waste container and waste bags in accordance with the safety data sheets, safety regulations and laboratory guidelines.



WARNING! Danger due to contamination of the LiquidWasteTub.

The outer surface of the LiquidWasteTub may become contaminated by pipette tips in the waste container.

- ▶ Wear your personal protective equipment.
- ▶ Decontaminate the outer surface of the LiquidWasteTub.

Complete the following steps after the end of the application.

1. Seal the vessels.
2. Remove the labware from the worktable.
3. Empty the waste container.
4. If required, decontaminate the device and the labware (see *Decontamination and cleaning on p. 111*).

9.4.2 Switching off epMotion



NOTICE! Data loss due to incorrect shutdown of the device.

If you switch off the device without ending the running processes, data will be lost.

- ▶ Switch off the device as described in the operating manual.

Proceed as follows:

1. Exit epBlue (refer to the epMotion software manual).
2. Shutdown the MultiCon PC and switch it off.
3. The EasyCon tablet switches off automatically. The display goes dark.
4. Switch off the epMotion using the mains/power switch.

10 Maintenance

10.1 Decontamination and cleaning



WARNING! Danger due to flammable and infectious liquids in the waste container and waste bags.

Pipette tips in the waste container and in waste bags may contain flammable or infectious liquids.

- ▶ Wear your personal protective equipment.
- ▶ Handle the pipette tips and sample material from the waste container and waste bags in accordance with the safety data sheets, safety regulations and laboratory guidelines.
- ▶ Dispose of the pipette tips and sample material from the waste container and waste bags in accordance with the safety data sheets, safety regulations and laboratory guidelines.



WARNING! Danger due to contamination of the LiquidWasteTub.

The outer surface of the LiquidWasteTub may become contaminated by pipette tips in the waste container.

- ▶ Wear your personal protective equipment.
- ▶ Decontaminate the outer surface of the LiquidWasteTub.



NOTICE! Material damage from corrosive cleaning agents.

Cleaning and decontamination agents may contain corrosive substances. Metal surfaces on the device become damaged by corrosion.

- ▶ Use the cleaning agents and disinfectants specified in the operating manual.
-

10.1.1 Cleaning

Auxiliary equipment

- Deionized water
- Lint-free cloths
- Cotton swabs

Prerequisites

- The device is switched off and disconnected from the mains/power line.

1. Moisten the lint-free cloth and cotton swab with deionized water.
2. Clean the surfaces using the lint-free cloth. Use the cotton swabs to clean hard to reach surfaces.
3. Allow the surfaces to dry.

10.1.2 Decontamination methods and decontamination agents

Tab. 10-1: Decontamination methods and decontamination agents

Decontamination method	Decontamination agent	Use for
Wipe decontamination	70% (v/v) ethanol	Worktable Waste container LiquidWasteTub Waste bag holder Housing Worktable base adapter Reflectors and sensor covers on the Cleanbench MultiCon PC EasyCon tablet Barcode reader Labware Dispensing tools
	3%–4% sodium hypochlorite solution	Waste container LiquidWasteTub Dispensing tools Racks Thermoblocks Thermoadapter Height adapter TipHolder
Spray decontamination outside of the device	70% (v/v) ethanol	Waste container LiquidWasteTub Waste bag holder Racks Thermoblocks Thermoadapter Height adapter TipHolder
UV irradiation using Cleanbench	UV light of the Cleanbench Irradiation period of 15 min If you perform UV irradiation regularly, the epMotion must be serviced once a year by the authorized service.	Worktable without labware and tools
Autoclaving	121 °C 100 kPa positive pressure 20 min	Waste container LiquidWasteTub Dispensing tools Racks Thermoblocks Thermoadapter Height adapter TipHolder

10.1.3 Performing a wipe decontamination

Use wipe decontamination to clean the device, tools, accessories and labware. Details can be found in the (see p. 112) chapter.

Auxiliary equipment

- Decontamination agent
- Deionized water
- Lint-free cloths
- Cotton swabs

Prerequisites

- The device is switched off and disconnected from the mains/power line.
1. Moisten the lint-free cloth and cotton swab with a decontamination agent.
 2. Clean the surfaces using the lint-free cloth. Use the cotton swabs to clean hard to reach surfaces.
The surfaces are dampened with a decontamination agent.
 3. Allow the decontamination agent to take effect.
 4. Wipe off the decontamination agent with deionized water.
 5. Allow the surfaces to dry.

Wipe decontamination on the dispensing tool

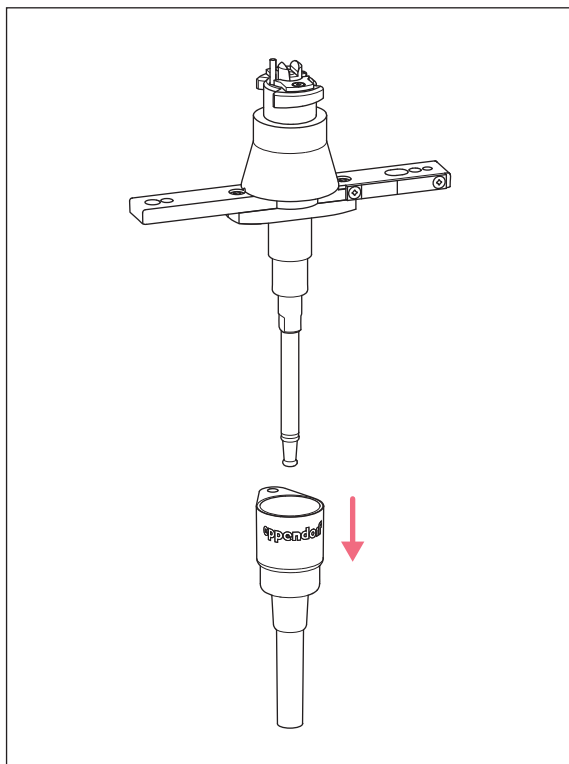

6. Remove the ejector sleeve of the single-channel dispensing tool.
7. Perform the wipe decontamination as described.

Fig. 10-1: Single-channel dispensing tool with ejector sleeve

10.1.4 Performing a spray decontamination



NOTICE! Damage to device from the ingress of liquid during spray decontamination.

- ▶ Do not use spray decontamination to clean the device.
 - ▶ Remove the labware and tools from the device before cleaning the labware and tools using spray decontamination.
-

Auxiliary equipment

- Decontamination agent in a spray bottle
- Deionized water

1. Remove the labware and the tools from the device.
2. Spray the labware and tools with decontamination agent.
3. Allow the decontamination agent to take effect.
4. Wipe off the decontamination agent with deionized water.
5. Allow labware and tools to dry.

10.1.5 Autoclaving



NOTICE! Damage to the tool due to autoclaving.

The tool will be damaged if the temperature in the autoclave is too high.

- ▶ Ensure that the temperature in the autoclave is 121 °C – 126 °C.
 - ▶ Ensure that the tools do not touch the wall of the autoclave.
-

Prerequisites

- The autoclave has been set up with 121 °C and a positive pressure of 100 kPa.
- Any chemical decontamination agents have been removed.

1. Autoclave the tools and labware for at least 20 min.
2. Rinse the tools and labware with deionized water.
3. Allow the tools and labware to dry.

10.1.6 Decontaminating the Magnum FLX magnetic adapter 96-well plates using 70 % ethanol solution

The Magnum FLX magnetic adapter 96-well plates must be decontaminated before and after each use with a 70% ethanol solution.

Prerequisites

- Solution with 70% ethanol
- Lint-free cloths
- Cotton swabs

1. Moisten the lint-free cloth and cotton swab with ethanol solution.
2. Clean the surfaces using the lint-free cloth.
3. Use the cotton swab and compressed air to remove strong salt encrustations.
4. Dry the magnetic adapter well using a dry cloth or compressed air.

10.1.7 Decontaminating the Magnum FLX magnetic adapter 96-well plates using an ortho-phthalaldehyde-based solution

Prerequisites

- Ortho-phthalaldehyde-based solution, e.g. CIDEX

1. Decontaminate the Magnum FLX magnetic adapter 96-well plates according to the instructions of the manufacturer of the decontamination agent.
2. After decontaminating the magnetic adapter with the ortho-phthalaldehyde-based solution, decontaminate it using a 70% ethanol solution.

10.2 Shipping the device

If an on-site repair is not possible, you can send the device to technical support in Hamburg, Germany.



WARNING! Infection by contaminated material.

There may be contaminated material on the device and accessories. People may infect themselves with contaminated material.

- ▶ Check the device decontamination certificate as well as the assemblies.
- ▶ Only send decontaminated devices and assemblies.



NOTICE! Risk of damage due to incorrect packing.

Incorrectly packed devices can be damaged during transport or storage. Eppendorf AG is not liable for any damage caused by improper packing.

- ▶ The device may only be stored and transported in its original packing.
-

Perform the following steps in the sequence described.

1. Check that all devices and assemblies you wish to send are decontaminated.
2. Download the decontamination certificate from the www.eppendorf.com/decontamination website.
Have the operator fill out the decontamination certificate.
3. Pack the decontamination certificate together with the device.
Deliveries shipped without a decontamination certificate will not be processed.
4. Ship the device.

10.3 Servicing the device



The Eppendorf AG performance plans are available to service and certify your device.

Services include:

- Installation qualification (IQ) and operational qualification (OQ)
- Service
- Calibration and validation

You can find information about the Performance plans on our website www.eppendorf.com.

- ▶ Have all dispensing tools be serviced by the authorized service after 100,000 full strokes or 200,000 strokes.
- ▶ If you irradiate your device regularly with UV light, have the device serviced by the authorized service once a year.

10.4 Fuses

Fuses may only be replaced by authorized service technicians. Users must not replace the fuses.

10.5 Checking the dispensing volume

The physical properties of a liquid affect the dispensing volume, e.g., viscosity, vapor pressure and surface tension. When you use liquids with a density greatly different from that of water, the dispensing volume may be incorrect.

Gravimetrically check the dispensing of the epMotion. Correct the dispensing volume if necessary.

Perform the following check:

Prerequisites

- Distilled water
- Test liquid

1. Call up the application.
2. Adjust the application to your labware and dispensing tool.
3. Weigh the destination labware.
4. Fill the source labware with distilled water.
5. Execute the application.
The destination labware is filled with distilled water.
6. Weigh the destination labware.
7. Calculate the volume of the water. $\text{Volume} = \text{mass} : \text{density}$.



Observe the ambient temperature for the density specification. The density of water at 20 °C is approx. 0.9982 g/mL.

8. Check to see if the dispensing tool dispenses liquid without errors. To do so, compare the calculated volume of water with the dispensing volume of the dispensing tool.
9. Repeat the check with test liquid and new labware.
10. Calculate the volume of the test liquid. $\text{Volume} = \text{mass} : \text{density}$.
11. Compare the volume of the water with the volume of the test liquid.
12. Change the dispensing volume if necessary.



Changing the density by 10% will change the volume by approx. 0.2% – 1%.

10.6 Servicing the dispensing tools



NOTICE! Dispensing errors due to lack of service.

To ensure that dispensing is executed according to the specifications, every dispensing tool must be serviced after 100,000 full strokes or 200,000 strokes. epBlue displays a message when a dispensing tool has reached 100,000 full strokes or 200,000 strokes.

- ▶ Have the dispensing tool serviced after 100,000 full strokes or 200,000 strokes.
- ▶ Send the dispensing tool to the authorized service partner.

10.6.1 Replacing the sealing rings on the dispensing tool

Replace the sealing rings in the following cases:

- The sealing rings are damaged.
- The pipette tips are not inserted in parallel.
- The pipette tips are dripping.
- Once a year
- During a service provision



NOTICE! Damage to the gold contacts from handling.

If the gold contacts of the tool are damaged or contaminated this will damage the tool.

- ▶ Do not touch the gold contacts.

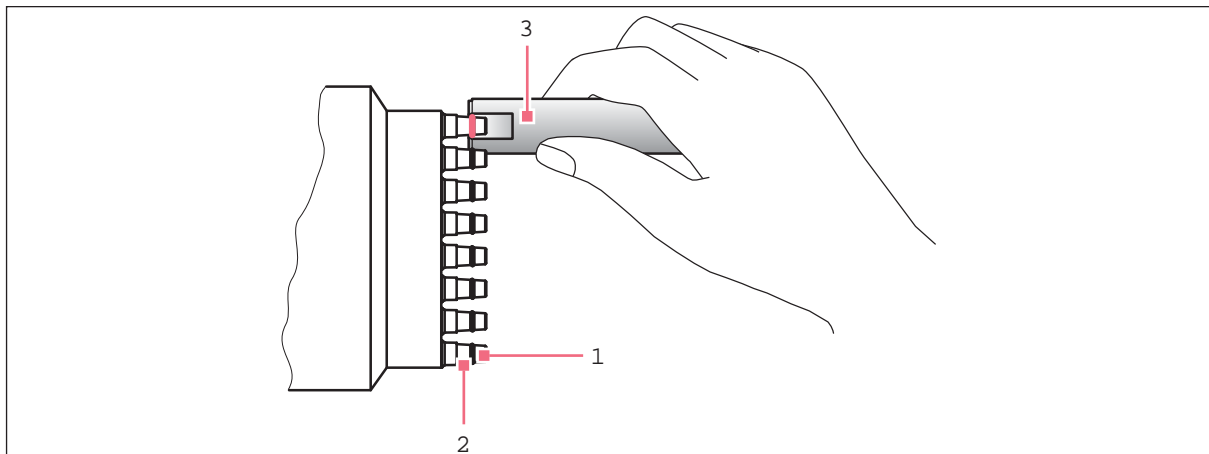

1 Sealing ring

3 Auxiliary tool

2 Tip cone

Prerequisites

- New sealing rings
- Auxiliary tool
- Mounting aid
- Damp, lint-free cloth

1. Place the edge of the auxiliary tool at the height of the sealing ring.
2. Use the auxiliary tool to cut the sealing rings on the dispensing tool.
3. Use your fingers to remove the sealing rings.
4. Clean all of the tip cones with a damp, lint-free cloth.
5. Use the mounting aid to attach the new sealing ring.
6. Position the sealing rings in the grooves of the tip cones.

10.7 Customer service functions

The following customer service functions are available for servicing and checking the device.

Customer service function	Description
<i>Tool interlock</i>	Check the locking mechanism of the tools.
<i>Backup tool</i>	Store tool data from the PCB of a tool in the epBlue software. The data is determined for a specific tool.
<i>Dosing device</i>	Display the number of piston movements of a dispensing tool.

The software manual contains a detailed description of the customer service functions.

11 Troubleshooting

If you cannot remedy an error with the recommended measures, please contact your local Eppendorf partner. The contact address can be found on the Internet at www.eppendorf.com.

11.1 Error search

If an application does not start, an error message appears. If you cannot eliminate the error using the suggested solution, please check the following points.

Device

- Is the front hood of the ep*Motion* or the safety glass of the Cleanbench fully closed?

Tools

- Are the required dispensing tools available?
- Have the tools been hung correctly in the holder?

Worktable

- Is the labware displayed in the software identical to the labware on the ep*Motion* worktable?
- Is the labware in the location shown on the display?
- Are all locations which are shown as empty in the software actually empty on the ep*Motion* worktable?

Labware

- Is the labware inserted correctly?
- Is the labware inserted the wrong way round?
- Are you using the correct height adapter?
- Are all tubes open?
- Are the epT.I.P.S. Motion racks sufficiently filled with pipette tips?
- Have the lids of the epT.I.P.S. Motion racks been removed?
- Are the lids of the Eppendorf Safe-Lock tubes positioned correctly?
- Are the minimum filling quantities present in the source positions?
- Are the racks or plates that will be required later prepared in the parking positions?
- Has the volume of the racks or plates that will be required later been entered in the application?

Waste container

- Is the waste container empty?
- Is the waste bag inserted correctly in the holder?
- Does the waste bag protrude into the adjacent locations?
- Can the bag hold the number of pipette tips required for the application?

Cleanbench

- Are the reflectors on the door of the cleanbench in order?
- Is the device positioned at the correct angle to the reflectors?

Barcode reader

- Is the barcode reader connected?
- Did you scan the required ID?
- Did you select the *Barcode-ID* function in epBlue?

11.2 General errors

11.2.1 Optical sensor error

Problem	Cause	Solution
The optical sensor does not detect the labware.	Plates are not level on the worktable. Plates were inserted the wrong way around.	▶ Check whether the labware is correctly inserted in the locations.
The optical sensor does not detect a plastic plate.	Plastic surface is uneven.	▶ Wipe the plate several times using a damp cloth. ▶ Use a damp plate to carry out a <i>Location</i> detection.
The optical sensor does not detect the filling level.	The surface of the liquid is not level. The surface of the liquid is heavily curved.	▶ Smooth the surface of the liquid. To do this, carefully tap the labware on the table.
	There are bubbles or foam on the surface of the liquid.	▶ Remove bubbles or foam.

11.2.2 Dispensing error

Problem	Cause	Solution
The dispensing tool dispenses incorrectly.	<ul style="list-style-type: none"> • The sealing rings on the dispensing tool are broken. 	▶ Replace the sealing rings on the dispensing tool.
Dispensing volume too high.	During retraction from the source position the opening of the pipette tip is in the liquid. There is no air bubble on the lower end of the pipette tip during liquid transport. <ul style="list-style-type: none"> • The actual volume in the source position is greater than the entered volume. 	▶ Measure the volume using the optical sensor. ▶ Enter the correct volume. ▶ Avoid different filling levels in the locations of a plate.
	<ul style="list-style-type: none"> • Liquid was refilled after starting the application without using the <i>set volume</i> command. 	▶ Only refill liquid when the <i>set volume</i> command is used.
	<ul style="list-style-type: none"> • Incorrect labware used. 	▶ Use the labware that is defined in the epBlue worktable.
Dispensing volume too low	The pipette tip draws in air. There are air bubbles in the pipette tip. <ul style="list-style-type: none"> • The actual volume in the source position is lower than the entered volume. 	▶ Measure the volume using the optical sensor. ▶ Enter the correct volume. ▶ Avoid different filling levels in the locations of a plate.
	<ul style="list-style-type: none"> • Incorrect labware used. 	▶ Use the labware that is defined in the epBlue worktable.

Problem	Cause	Solution
Residual liquid in pipette tip.	<ul style="list-style-type: none"> • An incorrect volume was entered for the destination position. • After dispensing the volume, liquid is drawn back into the pipette tip from the destination position. 	<ul style="list-style-type: none"> ▶ Use the optical sensor to determine the volume. ▶ Enter the correct volume. ▶ Avoid different filling levels in the locations of a plate.
	<ul style="list-style-type: none"> • Incorrect liquid type selected. • Unsuitable dispensing parameters. 	<ul style="list-style-type: none"> ▶ Select a liquid type that matches the liquid. ▶ Optimize the dispensing parameters (refer to the epMotion software manual).
	<ul style="list-style-type: none"> • Liquid wets the pipette tip. • Liquid tends to foam. 	<ul style="list-style-type: none"> ▶ Replace the pipette tip more often. ▶ Optimize the dispensing parameters (refer to the epMotion software manual).

12 Transport, storage and disposal

12.1 Transport



CAUTION! Risk of injury due to lifting and carrying heavy loads.

The device is heavy. Lifting and carrying the device can lead to back injuries.

- ▶ Only transport and lift the device with an adequate number of helpers.
- ▶ Use a transport aid to transport the device.

- ▶ Use the original packaging and the transport securing devices for transport.

	Air temperature	Relative humidity	Atmospheric pressure
General transport	-25 °C – 60 °C	10 % – 75 %	30 kPa – 106 kPa
Air freight	-20 °C – 55 °C	10 % – 75 %	30 kPa – 106 kPa

The center of gravity of the device is at the rear.

Yellow carrying straps are attached to the device for delivery.

- ▶ Use the yellow carrying straps to lift the device out of the packing and for installation.

12.2 Storage

	Air temperature	Relative humidity	Atmospheric pressure
In transport packing	-25 °C – 55 °C	10 % – 95 %	70 kPa – 106 kPa
Without transport packing	-5 °C – 45 °C	10 % – 95 %	70 kPa – 106 kPa

12.3 Disposal

Observe the relevant legal regulations when disposing of the product.

Information on the disposal of electrical and electronic devices in the European Community:

Within the European Community, the disposal of electrical devices is regulated by national regulations based on EU Directive 2012/19/EU pertaining to waste electrical and electronic equipment (WEEE).

According to these regulations, any devices supplied after August 13, 2005, in the business-to-business sphere, to which this product is assigned, may no longer be disposed of in municipal or domestic waste. They are marked with the following symbol to indicate this:

Transport, storage and disposal

epMotion® 5070

English (EN)



As the disposal regulations may differ from one country to another within the EU, please contact your supplier for more information.

13 Technical data

13.1 Power supply

Voltage	100 V – 240 V ±10 %
Fuses	AC 250 V/T 10 A, 5 mm × 20 mm
Mains/power cord	AC 250 V / 10 A, 3G 1.0 mm ² , C13 connector according to IEC 60320
Frequency	50 Hz – 60 Hz ±5 %
Power consumption in standby mode	50 W
Power consumption maximum	200 W
Overvoltage category	II (IEC 610 10-1)
Degree of pollution	2
Protection class	I

13.2 Ambient conditions

Environment	For indoor use only
Ambient temperature	15 °C – 35 °C
Relative humidity	55 % – 75 %, non-condensing
Atmospheric pressure	86 kPa – 106 kPa Use up to a height of 2 000 m above sea level.

13.3 Weight/dimensions

Dimensions	Width: 65 cm (25.6 in) Depth: 48 cm (18.9 in) Height: 63 cm (24.8 in) Height with open front panel: 120 cm (47.3 in)
Weight	epMotion 5070: 45 kg (99.2 lb) epMotion 5070f: 33 kg (72.8 lb)

13.4 Noise level

Noise level	typically 53 dB (A)
-------------	---------------------

13.5 Interfaces

USB	USB 2.0
Ethernet	Ethernet 100 MBit/s

Only connect devices that comply with the DIN EN 62368-1:2016-05 standards to the interfaces.

13.6 MultiCon PC

Dimensions	Width: 386 mm (15.20 in) Depth: 221 mm (8.71 in) Height: 369 mm (14.54 in)
Weight	With stand: 4.90 kg (10.80 lb) Without stand: 2.90 kg (6.39 lb)
Memory	RAM: 8 GB Hard disk: 128 GB

Detailed technical data can be found in the original operating manual of the MultiCon PC.

13.7 EasyCon tablet

Touchpanel	Capacitive touchpanel
Display	LCD color display
Display size	25.4 cm (10 in)
Resolution	1024 × 600 pixels
Weight	1.3 kg (2.87 lb)
Dimensions	Length: 29 cm (11.4 in) Depth: 18 cm (7.1 in) Height: 8 cm (3.2 in)
Power supply	Via Ethernet cable
Interfaces	USB 2.0 Ethernet 100 MBit/s
Memory	RAM: 2 GB Hard disk: 32 GB

Only connect devices to the interface that comply with the DIN EN 62368-1:2016-05 standards.

13.8 Additional specifications

13.8.1 Optical sensor

Optical confocal infrared sensor	Contact-free detection of <ul style="list-style-type: none"> • Filling level in the labware • Labware code and height • Number and location of the ep.T.I.P.S. pipette tips Motion in labware from Eppendorf
Detection conditions	90 ± 3° liquid surface to the optical axis Minimum filling level 3 mm

13.8.2 Carrier

Positioning accuracy along the X, Y and Z axes	
Systematic deviation	±0.3 mm
Random deviation	±0.1 mm
Workspace	Width: 370 mm Depth: 200 mm Height: 200 mm

13.9 Enhancements

13.9.1 Barcode reader

Type	Manual barcode reader
Connection	USB
Weight	
Supported barcodes	<ul style="list-style-type: none"> • linear: UPC, Code 39, Code 128, Interleaved 2 of 5, Codabar, GS1-DataBar, Code 93 • 2D: Data matrix, QR code, Micro-QR code, Aztec code • stacked: PDF 417, Micro PDF 417, Composite • postal: USPS-OneCode (4CB), POSTNET, PLANET, Japanese Post, Australian Post, Royal Mail, KIX code

13.9.2 Tip Tool

Dimensions	Width: 85 mm Depth: 27 mm Height: 230 mm
Weight	155 g

13.10 Dispensing tool errors

13.10.1 Pipetting

Dispensing tool	Volume range Pipetting	Testing volume	Maximum permissible errors			
			Error			
			Systematic		Random	
			± %	± µL	± %	± µL
TS 10	0.2 µL – 10 µL	0.2 µL	±25	±0.05	±19.8	±0.04
		1 µL	±5	±0.05	±3	±0.03
		5 µL	±2.4	±0.12	±0.5	±0.025
		10 µL	±1.2	±0.12	±0.25	±0.025
TS 50	1.0 µL – 50 µL	1 µL	±15.0	±0.15	±5.0	±0.05
		5 µL	±5.0	±0.25	±3.0	±0.15
		25 µL	±1.5	±0.375	±0.6	±0.15
		50 µL	±1.0	±0.5	±0.4	±0.2
TS 300	20 µL – 300 µL	20 µL	±4.0	±0.8	±2.5	±0.5
		30 µL	±3.0	±0.9	±1.5	±0.45
		150 µL	±1.0	±1.5	±0.4	±0.6
		300 µL	±0.6	±1.8	±0.3	±0.9
TS 1000	40 µL – 1 000 µL	40 µL	±5.0	±2.0	±1.5	±0.6
		100 µL	±2.0	±2.0	±1.0	±1.0
		500 µL	±1.0	±5.0	±0.2	±1.0
		1 000 µL	±0.7	±7.0	±0.15	±1.5
TM 10-8	0.2 µL – 10 µL	1 µL	±7.5	±0.075	±5	±0.05
		5 µL	±2.5	±0.125	±2	±0.1
		10 µL	±2	±0.02	±0.6	±0.06
TM 50-8	1.0 µL – 50 µL	1 µL	±25.0	±0.25	±10.0	±0.1
		5 µL	±5.0	±0.25	±5.0	±0.25
		25 µL	±2.0	±0.5	±1.2	±0.3
		50 µL	±1.2	±0.6	±0.6	±0.3
TM 300-8	20 µL – 300 µL	20 µL	±10.0	±2.0	±4.0	±0.8
		30 µL	±10.0	±3.0	±3.5	±1.05
		150 µL	±2.5	±3.75	±0.8	±1.2
		300 µL	±1.5	±4.5	±0.5	±1.5
TM 1000-8	40 µL – 1 000 µL	40 µL	±6.0	±2.4	±2.5	±1.0
		100 µL	±3.0	±3.0	±1.5	±1.5
		500 µL	±1.5	±7.5	±0.3	±1.5
		1 000 µL	±0.8	±8.0	±0.15	±1.5

13.10.2 Test conditions

Test conditions and test evaluation based on ISO 8655-6.

The errors for the volumes $\geq 1 \mu\text{L}$ were determined under the following conditions:

- Water in accordance with ISO 8655-6
- epT.I.P.S. Motion pipette tips with the purity grade Eppendorf Quality
- Free-jet dispensing

The errors for the volume $0.2 \mu\text{L}$ were determined by liquid dispensing in contact dispensing mode.

14 Ordering information

14.1 Tools

Order no. (International)	Description
5280 000.100	Single-channel dispensing tool TS 10 Volume range 0.2 µL - 10 µL
5280 000.010	Single-channel dispensing tool TS 50 Volume range 1 µL - 50 µL
5280 000.037	Single-channel dispensing tool TS 300 Volume range 20 µL - 300 µL
5280 000.053	Single-channel dispensing tool TS 1000 Volume range 40 µL - 1000 µL
5280 000.304	Eight-channel-dispensing tool TM 10-8 Volume range 0.2 µL - 10 µL
5280 000.215	Eight-channel-dispensing tool TM 50-8 Volume range 1 µL - 50 µL
5280 000.231	Eight-channel-dispensing tool TM 300-8 Volume range 20 µL - 300 µL
5280 000.258	Eight-channel-dispensing tool TM 1000-8 Volume range 40 µL - 1000 µL
5075 774.003	Holder for 6 dispensing tools
5075 751.895	Gripper Tower To be used with epMotion ReservoirRacks, for samples and reagents for NGS-specific application, requires epBlue as of version 40.7
5285 000.000	Tip Tool Tool for the transport of epT.I.P.S. Motion including racks and reload trays in ReservoirRack module Tips, incl. holder

14.2 epT.I.P.S. Motion

14.2.1 epT.I.P.S. Motion racks

Order no. (International)	Description
0030 014.383 0030 015.185	epT.I.P.S. Motion 10 µL 10 racks with 96 tips each Eppendorf Quality Sterile
0030 014.391 0030 015.193	epT.I.P.S. Motion Filter 10 µL 10 racks with 96 tips each PCR clean PCR clean and Sterile
0030 014.405 0030 015.207	epT.I.P.S. Motion 50 µL 10 racks with 96 tips each Eppendorf Quality Sterile
	epT.I.P.S. Motion Filter 50 µL 10 racks with 96 tips each

Ordering informationepMotion® 5070
English (EN)

Order no. (International)	Description
0030 014.413	PCR clean
0030 015.215	PCR clean and Sterile
0030 014.448	epT.I.P.S. Motion 300 µL 10 racks with 96 tips each Eppendorf Quality
0030 015.223	Sterile
0030 014.456	epT.I.P.S. Motion Filter 300 µL 10 racks with 96 tips each PCR clean
0030 015.231	PCR clean and Sterile
0030 014.480	epT.I.P.S. Motion 1 000 µL 10 racks with 96 tips each Eppendorf Quality
0030 015.240	Sterile
0030 014.499	epT.I.P.S. Motion Filter 1 000 µL 10 racks with 96 tips each PCR clean
0030 015.258	PCR clean and Sterile

14.2.2 epT.I.P.S. Motion SafeRacks

Order no. (International)	Description
0030 014.600	epT.I.P.S. Motion 50 µL 10 SafeRacks with 96 tips each Eppendorf Quality
0030 014.618	epT.I.P.S. Motion Filter 50 µL 10 SafeRacks with 96 tips each PCR clean
0030 014.626	epT.I.P.S. Motion 300 µL 10 SafeRacks with 96 tips each Eppendorf Quality
0030 014.634	epT.I.P.S. Motion Filter 300 µL 10 SafeRacks with 96 tips each PCR clean
0030 014.642	epT.I.P.S. Motion 1 000 µL 10 SafeRacks with 96 tips each Eppendorf Quality
0030 014.650	epT.I.P.S. Motion Filter 1 000 µL 10 SafeRacks with 96 tips each PCR clean

14.2.3 epT.I.P.S. Motion Reloads

Order no. (International)	Description
0030 014.545	epT.I.P.S. Motion Reloads 10 µL 12 × 2 trays with 96 tips each Eppendorf Quality
0030 014.553 0030 014.561	epT.I.P.S. Motion Filter Reloads 10 µL 12 × 2 trays with 96 tips each PCR clean PCR clean and Sterile
0030 014.421	epT.I.P.S. Motion Reloads 50 µL 12 × 2 trays with 96 tips each Eppendorf Quality
0030 014.430 0030 014.529	epT.I.P.S. Motion Filter Reloads 50 µL 12 × 2 trays with 96 tips each PCR clean PCR clean and Sterile
0030 014.464	epT.I.P.S. Motion Reloads 300 µL 12 × 2 trays with 96 tips each Eppendorf Quality
0030 014.472 0030 014.537	epT.I.P.S. Motion Filter Reloads 300 µL 12 × 2 trays with 96 tips each PCR clean PCR clean and Sterile
0030 014.502	epT.I.P.S. Motion Reloads 1 000 µL 12 × 2 trays with 96 tips each Eppendorf Quality
0030 014.510 0030 014.570	epT.I.P.S. Motion Filter Reloads 1 000 µL 12 × 2 trays with 96 tips each PCR clean PCR clean and Sterile

14.2.4 Adapter

Order no. (International)	Description
5075 751.399	TipHolder for epT.I.P.S. Motion Reloads

Ordering information

epMotion® 5070
English (EN)

14.2.5 Accessories

Order no. (International)	Description
0030 014.669	Box for epT.I.P.S. Motion 10 µL, 50 µL, 300 µL 10 pieces
0030 014.677	Box for epT.I.P.S. Motion 1 000 µL 10 pieces
5075 751.070	Clip for epT.I.P.S. Motion Reloads 5 pieces

14.3 Plates



All twin.tec plates are available with an ID on request.
Information about other plates can be found in our catalog and on our website
www.eppendorf.com

Order no. (International)	Description
0030 128.648	Eppendorf twin.tec PCR Plate 96 skirted, 150 µL PCR clean, colorless, 25 pcs.
0030 128.656	twin.tec PCR Plate 96, skirted low profile, wells colorless, 25 pieces
0030 128.664	
0030 128.672	
0030 128.680	
0030 128.800	twin.tec PCR Plate 96, skirted Wells black, 25 pieces border yellow
0030 128.575	Eppendorf twin.tec PCR Plate 96 semi-skirted, 250 µL PCR clean, colorless, 25 pcs.
0030 128.583	twin.tec PCR Plate 96, semi-skirted wells colorless, 25 pieces
0030 128.591	
0030 128.605	
0030 128.613	
0030 129.326	Eppendorf twin.tec microbiology PCR plate 96 semi-skirted, 250 µL PCR clean, colorless, 10 pcs.
0030 129.334	Eppendorf twin.tec microbiology PCR Plate 96 semi-skirted, 250 µL PCR clean, blue, 10 pcs.

Order no. (International)	Description
0030 129.504	Eppendorf twin.tec PCR Plates 96 LoBind, semi-skirted PCR clean, colorless, 25 pcs.
0030 132.530 0030 132.556	twin.tec real-time PCR Plate 96 semi-skirted wells white, 25 pieces border blue border black
0030 132.548	Eppendorf twin.tec 96 real-time PCR Plate semi-skirted, 250 µL PCR clean, white, 25 pcs.
0030 128.508	Eppendorf twin.tec PCR Plate 384 skirted, 40 µL PCR clean, colorless, 25 pcs.
0030 128.516 0030 128.524 0030 128.532 0030 128.540	twin.tec PCR Plate 384 wells colorless, 25 pieces border yellow border green border blue border red
3881 000.015	PCR-Cooler Starter Set (1 × pink, 1 × blue)
3881 000.023 3881 000.031	PCR-Cooler 0.2 mL Pink Blue

14.4 Reservoirs

Order no. (International)	Description
0030 126.521 0030 126.505 0030 126.513	Reservoir for ReservoirRack Modul PCR clean, 10 × 5 pieces in bags 10 mL 30 mL 100 mL
5075 751.364	Reservoir 400 mL 10 reservoirs, PCR clean, autoclavable 10 pieces

14.5 Racks

14.5.1 Racks for individual tubes

Order no. (International)	Description
5075 792.109 5075 763.001	Racks for individual tubes cannot be tempered, for use with Eppendorf vessels and glass or plastic test tubes Ø 12 mm × 60 mm max. length Ø 12 mm × 100 mm max. length

Ordering information

epMotion® 5070
English (EN)

Order no. (International)	Description
5075 792.087	Ø 13 mm x 60 mm max. length
5075 762.005	Ø 13 mm x 100 mm max. length
5075 792.060	Ø 14 mm x 60 mm max. length
5075 792.001	Ø 14 mm x 100 mm max. length
5075 792.044	Ø 15 mm x 60 mm max. length
5075 792.028	Ø 15 mm x 100 mm max. length
5075 776.006	Ø 16 mm x 60 mm max. length
5075 760.002	Ø 16 mm x 100 mm max. length
5075 775.000	Ø 17 mm x 60 mm max. length
5075 761.009	Ø 17 mm x 100 mm max. length
	Rack cannot be tempered, for 24 Safe-Lock tubes
5075 751.453	0,5 mL/1,5 mL/2,0 mL, with adapter for tubes für 0.5 mL
5075 751.275	1,5 mL/2,0 mL
	Rack for 24 HPLC vials
5075 792.125	Ø 12 mm x 40 mm max. length
	Rack for 96 conical tubes
5075 791.005	1.5 mL /2.0 mL
	Rack Smart for 16 SmartCycler test tubes
5075 790.009	
	Rack LC for 96 LightCycler capillaries
5075 795.000	20 µL/100 µL
	Rack for ILMN tubes Rack for individual tubes, 40 x ø 8.4 mm, 12 x ø 11.2 mm
5075 751.747	

14.5.2 Thermoracks

Order no. (International)	Description
	Thermorack for 24 Safe-Lock tubes
5075 769.000	0.5 mL
5075 771.004	1.5 mL/2.0 mL
	Adapter for thermorack 1.5 mL/2.0 mL for holding Safe-Lock tubes 0.5 mL
5075 772.000	
	Thermorack for 24 Cryo tubes
5075 777.055	
	Thermorack TMX for 24 Safe-Lock tubes
5075 751.160	0.5 mL
5075 751.186	1.5 mL/2.0 mL

Order no. (International)	Description
5075 767.031	Thermorack CB for 384 tube strips 100 µL
5075 751.526	Thermorack Rotor/Tubes
5075 751.640	Lid for Thermorack Rotor/Tubes with adapter for placing the lid on the epMotion worktable

14.5.3 ReservoirRacks

Order no. (International)	Description
5075 754.002	ReservoirRack for 10 mL, 30 mL and 100 mL reservoirs and ReservoirRack Module TC

14.5.4 ReservoirRack modules

Order no. (International)	Description
5075 799.049	ReservoirRack Module TC temperature-controlled, usable in ReservoirRacks, for the following tubes 8 PCR micro test tubes 0.2 mL 4 Safe-Lock tube 1.5 mL/2 mL 4 test tubes 12 mm diam. 4 test tubes 16 mm diam. 4 test tubes 17 mm diam. 2 test tubes 29 mm diam. 1 Reservoir 10 mL 1 Reservoir 30 mL 1 Reservoir 100 mL 4 Eppendorf Tubes 5.0 mL
5075 799.081	
5075 799.103	
5075 799.120	
5075 799.162	
5075 799.189	
5075 799.421	
5075 799.146	
5075 799.260	
5075 799.340	
5075 751.917	ReservoirRack module NGS To be used with epMotion ReservoirRacks, for samples and reagents for PCR, requires epBlue as of version 40.7
5075 751.933	ReservoirRack module PCR To be used with epMotion ReservoirRacks, for epT.I.P.S. Motion, set comprising 7 modules, requires epBlue as of version 40.7
5075 751.950	ReservoirRack module Tips To be used with epMotion ReservoirRacks, for epT.I.P.S. Motion, set comprising 7 modules, requires epBlue as of version 40.7

Ordering informationepMotion® 5070
English (EN)**14.6 Adapter****14.6.1 Height adapter**

Order no. (International)	Description
	Height adapter
5075 751.003	85 mm
5075 752.000	55 mm
5075 755.009	40 mm

14.6.2 Thermoadapter

Order no. (International)	Description
	Thermoadapter
5075 787.008	for PCR plates, 96 wells, skirted
5075 788.004	for PCR plates, 384 wells, skirted
	Thermoadapter DWP 96
5075 751.054	for Eppendorf Deepwell-Plates 96/1000 µL
	Thermoadapter LC Sample
5075 751.305	for MagNA Pure LC sample cartridge
	Thermoadapter Frosty
5075 789.000	Combination of height adapter and PCR cooler for PCR plates, skirted
	Thermoadapter Microplate 96/V/U
5075 751.577	for Microplate 96/V/U

14.6.3 Magnetic adapter

Order no. (International)	Description
	Magnum FLX magnet adapter 96-well plates
5075 751.836	for epT.I.P.S. Motion reload trays and epT.I.P.S. Motion racks, requires epBlue as of version 40.7

14.7 Thermoblocks

Order no. (International)	Description
	Thermoblock
5075 766.000	for 96 test tubes 0.2 mL, 77 PCR tubes 0.5 mL or a PCR plate with 96 wells
5075 767.007	for a PCR plate with 384 wells
	Thermoblock DWP 2000
5075 751.330	for Eppendorf Deepwell-Plates 96/2000 µL
	Thermoblock PCR 96 OC
5075 751.666	

14.8 Accessories

Worktable base adapters may only be mounted by authorized service technicians.

Order no. (International)	Description
5075 753.006	Waste box for used pipette tips
5075 753.103	Waste bag holder for epMotion 5070/5073/5075 waste position
5075 751.720	LiquidWasteTub 400 mL to mount in waste box and holder for waste frame with lid, autoclavable, working volume 400 mL
5075 751.763	Waste bag for risk material 50 pieces
5075 751.780	Waste bag for standard material 50 pieces
5070 752.001	Worktable base adapter to raise the epMotion worktable 4 pieces
0030 014.669	Box for epT.I.P.S. Motion 10 µL, 50 µL, 300 µL 10 pieces
0030 014.677	Box for epT.I.P.S. Motion 1 000 µL 10 pieces
5075 751.070	Clip for epT.I.P.S. Motion Reloads 5 pieces

Ordering information

epMotion® 5070
English (EN)

14.9 Modification kits and enhancements

Modification kits and enhancements may only be mounted by authorized service technicians.

Order no. (International)	Description
5075 757.001	Thermal module for heating or cooling the thermoadapter, thermoblock, or thermorack
5075 000.964	Enhanced Feature Set 1 License for epBlue features: number of sample flexibility, intelligent selection 1- or 8-channel dispensing tool, start methods at any step, e-mail notifications (MultiCon), requires service visit and epBlue > 40.6
5075 002.701	epBlue ID Modification kit for epMotion with MultiCon PC as of serial number 4000 with barcode reader
5075 002.728	epBlue GxP Modification kit for epMotion with MultiCon PC as of serial number 4000 with documentation folder
5075 014.220 5075 014.300	Eppendorf epMotion Editor 40 used to create, edit and simulate application on a PC, compatible with epBlue software CD ROM with software manual additional license

Index

A

Accessories	
Ordering information	141
Adapter	
Ordering information	140
Placement	106
Application	
Checking the labware	121
Application run	
Abort	109
Continue	109
Control	108
Pause	109
Start	108
Stop	108
Aspirate from a defined height	
Default	50
Aspirate from defined height	49
Custom	51
Fix	52
Autoclaving	114

B

Barcode reader	37
Decontamination and cleaning	112
Technical data	129
Bottom tolerance	44

C

Carrier	
Technical data	129
Cleanbench	
Decontamination and cleaning	112
Properties	30
Cleaning	111
Decontamination and cleaning	111
Contact dispensing	55

D

Decontamination	
Autoclaving	114
Spray decontamination	114
Wipe decontamination	113
Deepwell plate	63
Device	
Principle of operation	30
Switching off	110
Switching on	101
Dispense from defined height	57
Custom	59
Default	58
Fix	60
Dispensing	39
Checking the dispensing volume	117
Dispensing error	122
Dispensing mode	
Dispensing	39
Mixing	43
Pipetting	39
Dispensing tool	36
Decontamination and cleaning	112
Dispensing error	122
Placement	103
Principle of operation	39
Replacing the sealing rings	118
Disposal	125
Dry contact dispensing	55, 57

E

EasyCon tablet	
Decontamination and cleaning	112
Interface	26
Technical data	128
epT.I.P.S. Motion	67
Accessories	136
Adapter	135
Multiple use	69
Ordering information	133
Placement	104
Rack	68
Reload	135

- SafeRack69, 134
- Stacking70
- TipHolder71
- Error message
 - Dispensing error 122
 - Optical sensor read error 122
- Error search..... 121

- F**
- Free jet dispensing54, 56, 57

- H**
- Height adapter.....87

- L**
- Labware
 - Bottom tolerance.....44
 - Decontamination and cleaning 111
 - epT.I.P.S. Motion67
 - Height adapter87
 - LiquidWasteTub 98
 - Placement103, 105
 - Plate62
 - rack75, 76
 - Reservoir65
 - ReservoirRack79
 - ReservoirRack-Modul.....80
 - Thermoadapter88
 - Thermoadapter Frosty90
 - Thermoadapter Microplate 96/V/U.....89
 - Thermoblock92
 - Thermoblock PCR 96 OC93
 - Thermorack.....77
 - TipHolder71
 - Tubes.....61
 - Waste bag holder97
 - Waste box96
- Liquid aspiration44
 - From a defined height.....49
 - From a defined position52
 - From the vessel base.....47
 - On a defined distance51
 - With a constant immersion depth.....45, 50
- Liquid dispensing
 - At the height of the edge of the vessel..... 56
 - From a defined height 57
 - From a defined position 60
 - In a free jet 54
 - On a defined distance..... 59
 - With a constant immersion depth 58
 - With contact to the surface 55
- Liquid transport 53
- LiquidWasteTub..... 98
 - Inserting in waste containers 99
 - Placement..... 104
- Location
 - Connections..... 31
 - Prerequisites..... 31

- M**
- Micro test tube
 - Placement..... 105
- Microplate..... 64
- Mixing liquids..... 43
- Modification kit
 - Ordering information 142
- Multiaspirate..... 39
- MultiCon PC
 - Decontamination and cleaning..... 112
 - Technical data 128

- N**
- Noise level 127

- O**
- Optical sensor 34
 - Read error 122
 - Technical data 129
- Ordering information
 - Accessories..... 141
 - Adapter 140
 - epT.I.P.S. Motion 133
 - Modification kit 142
 - Plate..... 136
 - Rack..... 137

Reservoir	137	Reservoir	
Thermoblock	140	Ordering information	137
Tool	133	Reservoir 100 mL	66
P		Reservoir 10 mL	65
PCR plate	62	Reservoir 30 mL	65
Performance Plans	116	Reservoir 400 mL	66
Pipette tips		ReservoirRack module	
epT.I.P.S. Motion	67	Placement	105
epT.I.P.S. Motion rack	68	S	
epT.I.P.S. Motion SafeRack	69	Safety equipment	21
Multiple use	69	Service	116
Placement	104	Dispensing tool	118
Stacking	70	Dispensing tool sealing rings	118
TipHolder	71	Spray decontamination	114
Pipetting	39	Storage	125
Placement		T	
Adapter	106	Technical data	
Dispensing tool	103	Ambient conditions	127
Micro test tube	105	Barcode reader	129
Plate	106	Carrier	129
Rack	106	EasyCon tablet	128
ReservoirRack module	105	MultiCon PC	128
Waste container	104	Noise level	127
Plate	62	Optical sensor	129
Deepwell plate	63	Tip Tool	129
Microplate	64	Test run	107
Ordering information	136	Thermoadapter	
PCR plate	62	Thermoadapter Frosty	89
Placement	106	Thermoadapter LC samples	88
R		Thermoadapter Frosty	
rack		Description	89
Rack 0.5/1.5/2.0 mL	76	Preparation	90
Rack for 24 vessels	75	Thermoadapter LC samples	
Rack for 96 conical vessels	75	Description	88
Rack LC	76	Thermoadapter Microplate 96/V/U	89
ReservoirRack	79	Thermoblock	92
ReservoirRack-Modul	80	Ordering information	140
Remaining volume	45	Preparation	92
		Thermoblock PCR 96 OC	93

Index

epMotion® 5070
English (EN)

Thermorack	
Thermorack 0.5/1.5/2.0 mL.....	77
Tip Tool	
Technical data	129
Tool	
Decontamination and cleaning	111
Dispensing tool	36
Ordering information	133
Tools	
Placement	103
Touch screen	
Application	101
Transport	
Liquid	53
W	
Warning symbol	21
Waste bag holder	97
Waste box.....	96
Waste container	
LiquidWasteTub	98
Waste bag holder	97
Waste box	96
Wet contact dispensing	55, 57
Wipe decontamination	113
Workflow	102
Worktable	
Cleaning up.....	110
Decontamination and cleaning	111
Locations.....	33
Placing dispensing tools	103
Placing epT.I.P.S. Motion	104
Placing labware.....	105
Placing the LiquidWasteTub	104
Placing the waste container	104
Placing tools and labware	103
Worktable base adapter	
Decontamination and cleaning	112

Declaration of Conformity

The product named below fulfills the requirements of directives and standards listed. In the case of unauthorized modifications to the product or an unintended use this declaration becomes invalid. This declaration of conformity is issued under the sole responsibility of the manufacturer.

Product name:

epMotion® 5075, epMotion® 5073, epMotion® 5070

including accessories

Product type:

automated pipetting system

Relevant directives / standards:

2014/35/EU: EN 61010-1, EN 61010-2-010, EN 61010-2-051, EN 61010-2-081

UL 61010-1, CAN/CSA C22.2 No. 61010-1

2014/30/EU: EN 61326-1, EN 55011

2011/65/EU: EN 50581

EN ISO 8655-1, EN ISO 8655-2, EN ISO 8655-5, EN ISO 8655-6, EN ISO 8655-7, EN ISO 14971

Hamburg, September 13, 2018



Dr. Wilhelm Plüster
Management Board



Dr. Jochen Müller-Ibeler
Head of Business Unit
Automation

Your local distributor: www.eppendorf.com/contact
Eppendorf AG · Barkhausenweg 1 · 22339 Hamburg · Germany
eppendorf@eppendorf.com

Eppendorf® and the Eppendorf Brand Design are registered trademarks of Eppendorf AG, Germany.
U.S. Design Patents are listed on www.eppendorf.com/ip.
All rights reserved, incl. graphics and pictures. Copyright ©2018 by Eppendorf AG.

www.eppendorf.com

ISO
9001
Certified

ISO
13485
Certified

ISO
14001
Certified

Evaluate Your Manual

Give us your feedback.

www.eppendorf.com/manualfeedback

Your local distributor: www.eppendorf.com/contact

Eppendorf AG · Barkhausenweg 1 · 22339 Hamburg · Germany
eppendorf@eppendorf.com · www.eppendorf.com