

Instruction Manual

MODULY0D *FreezeDryer*



203-3500-00 Rev. D

Analyze • Detect • Measure • Control™

Thermo
ELECTRON CORPORATION

Table of Contents

Section	Section Title — Introduction	Page
1.0	Introduction	4
1.1	Scope of the Manual	4
1.2	General Description	4
1.2.1	The ModulyoD	4
	Figure 1-ModulyoD	5
	Figure 2-ModulyoD Back view	5
1.2.1.1	The Accessory Flange & Condenser Chamber	6
1.2.1.2	The Refrigeration System	5
	Figure 3-Inside ModulyoD	7
	Figure 4- Refrigeration Circuit Diagram	7
1.2.1.3	User Interface	8
	Table 1-Control Panel Description	8
	Figure 5-ModulyoD Control Panel	9
	Figure 6-Temperature Progress Bar	9
	Figure 7-Vacuum Progress Bar	9
1.2.1.4	Front Fascia	9
1.2.1.5	Connections	10
	Table 2-Drain Outlet Description	10
1.2.1.6	Condenser Extension Assembly	10
	Figure 8-The Condenser Extension Tube	11
1.3	Protection Devices	11
1.4	Applications	11
1.4.1	Introduction	11
1.4.2	The Freezing Process	12
1.4.3	The Drying Process	12
1.4.4	Vapor Trapping	12

Section	Section Title — Technical Data	Page
2.0	Technical Data	13
2.1	General	13
2.2	Refrigeration System	13
2.3	Electrical Data	13
2.4	Construction Details	14
2.4.1	Legislation and Standards	14
2.4.2	Constructions Materials	14
2.5	Vacuum Pump Requirements	14

Table of Contents

Section	Section Title — Installation	Page
3.0	Installation	15
3.1	Unpack and Inspect	15
	Table 3- Checklist of Components	15
3.2	Site Preparation	15
3.3	Connect the ModulyoD to the Electrical Supply	16
3.4	Connect the Vacuum Pump	16
3.5	Connect a Vacuum Pump to the ModulyoD	16
	Figure 9-Connect a VLP195FD or VLP120 Pump to the ModulyoD	17
3.6	Pump Outlet Safety	17
3.7	Test After Installation	17-18

Section	Section Title — Operation	Page
4.0	Operation	19
4.1	Safety	19
4.2	Sequence of Operation	19
	Table 4-Sequence of Operation	19
4.3	Prepare the ModulyoD	20
4.4.	Fit the Sample Container and Other Accessories	20
4.5	Pre-Cool the ModulyoD	20-21
4.6	Drying	21-22
4.7	Shut Down	22
4.8	Defrost the ModulyoD	23
4.9	Operation With No Load	24

Section	Section Title — Maintenance	Page
5.0	Maintenance	24
5.1	Safety	24
5.2	Precautions	24
5.3	Refrigerant Leaks	25

Section	Section Title — Accessories	Page
6.0	Accessories/Drying Accessories	25

Section	Section Title — Warranty & Appendices	Page
7.0	Warranty and Liability	26
	Appendix A - Using the ModulyoD as a Cold Trap	26
	Appendix B - Decision Tree	27
	Freeze Drying User's Log	28

1.0 INTRODUCTION

1.1 SCOPE OF THE MANUAL

This manual provides installation and operation instructions for the Thermo Electron ModulyoD Freeze Dryer, abbreviated to ModulyoD in the remainder of this manual. You must use the ModulyoD as specified in this manual.

Read this manual before installing and operating the ModulyoD. Important safety information is highlighted as WARNING and CAUTION instructions; you must obey these instructions. The use of WARNINGS and CAUTIONS is defined below.

WARNING: Warnings are given where failure to observe the instruction could result in injury or death to people.

CAUTION: Cautions are given where failure to observe the instruction could result in damage to equipment, associated equipment and process.

In accordance with the recommendations of IEC1010, the following warning symbols may appear on the freeze dryer:



Caution - refer to accompanying documents



Caution - risk of electric shock



Caution - hot surface

1.2 GENERAL DESCRIPTION

1.2.1 THE MODULYOD

The ModulyoD is the ice condenser section of a freeze drying system. It is designed specifically for freeze drying biological samples and pharmaceutical preparations in a laboratory environment. The ModulyoD, when used in conjunction with a vacuum source and manifold or other sample container, forms a complete freeze drying system. The ModulyoD may also be suitable for use as a low temperature (-50 °C.) vapor trap. Please refer to Appendix A for specific limitations regarding the use of the ModulyoD as a vapor trap.

The ModulyoD is used with a variety of optional accessories to freeze materials in bulk trays, flasks, tubes, vials or ampules. These optional accessories are described in Section 6.0 and depicted in Appendix B. The ModulyoD may also be used as a low temperature vapor trap (cold trap) for a variety of devices. These include vacuum concentrators, rotary evaporators and vacuum ovens.

The ModulyoD itself is made of three basic parts, the condenser chamber, a refrigeration system and the user interface. The refrigerant used in the ModulyoD is CFC free. All ModulyoD components are housed in a steel cabinet that is designed for bench-top use. The major components of the ModulyoD are described in the following sections. (Please refer to Figures 1 and 2 on page 4 for the location of each component.)

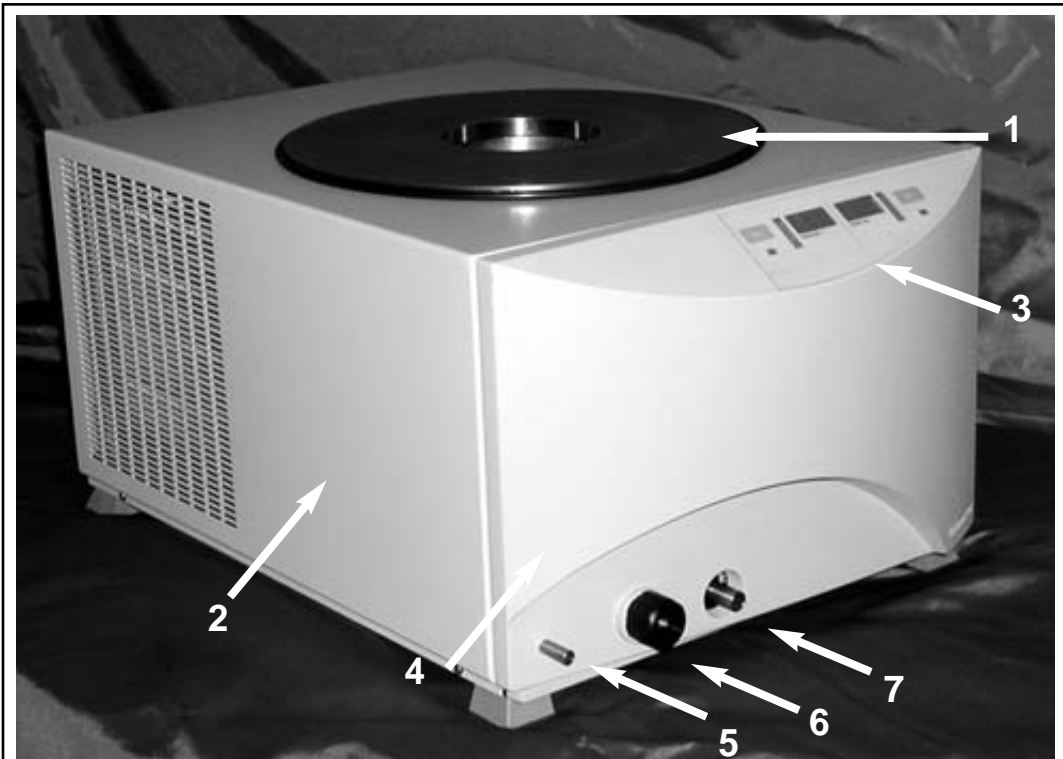

Figure 1 – MODULYOD

1. Condenser Chamber Accessory Flange & Condenser Chamber
2. Steel Cabinet with Refrigeration System
3. User Interface
4. Front Fascia
5. Drain Outlet
6. Drain Valve
7. Vacuum Port

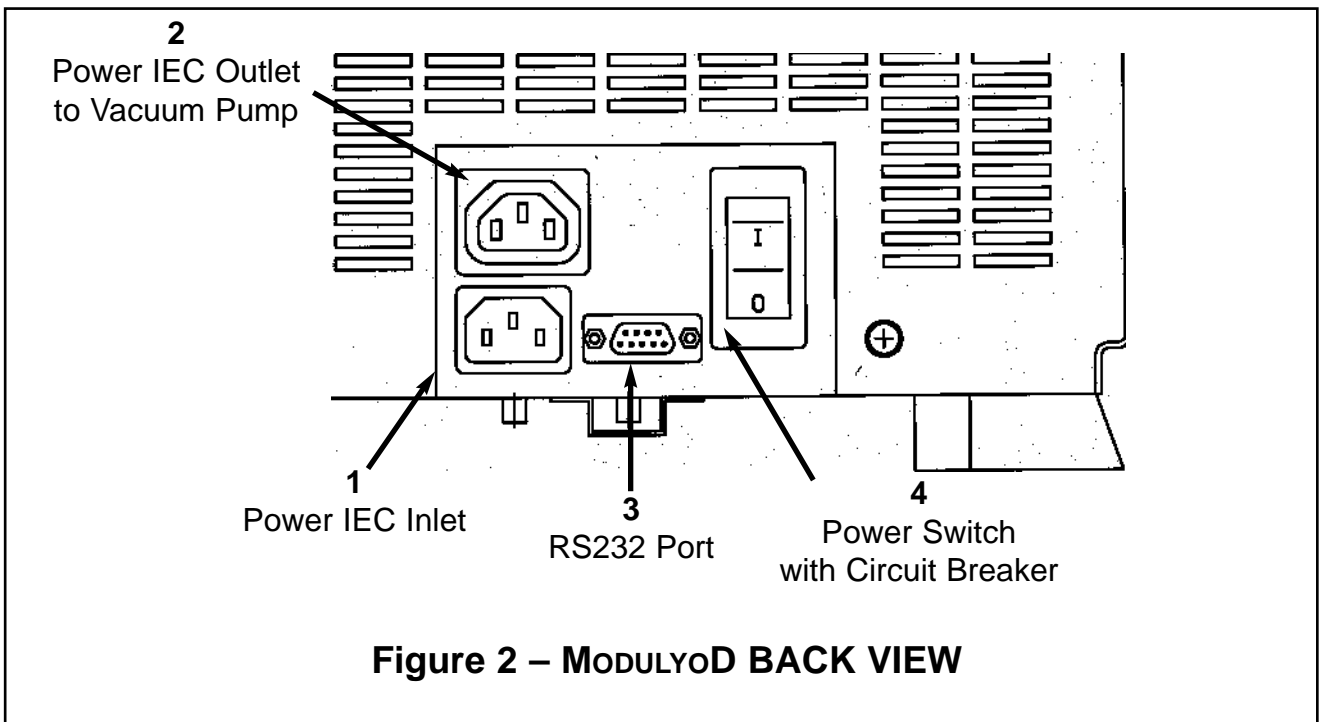

Figure 2 – MODULYOD BACK VIEW

1.2.1.1 THE ACCESSORY FLANGE & CONDENSER CHAMBER

The accessory flange and condenser chamber are made entirely of stainless steel. The chamber itself is a thin walled cylinder with a dish shaped bottom. It has a total capacity of 5 liters of ice. The accessory flange is a large diameter flat circular plate located immediately above the chamber. The accessory flange is designed to accept a wide variety of accessory items. A large opening in the center of the accessory flange provides easy inspection, cleaning and defrosting of the condenser chamber. It also facilitates high vacuum pumping rates. A circular cooling coil wrapped around the outside of the condenser chamber cools the walls of the chamber. This coil is cooled to approximately -50 °C under normal operating conditions with no load applied. At this temperature most water vapor will condense and freeze on the chamber walls.

1.2.1.2 THE REFRIGERATION SYSTEM

Refer to Figure 3, on page 6 for the location of components of the refrigeration system on the ModulyoD.

NOTE: There are no longer user-serviceable parts inside the ModulyoD refrigeration system.

The condenser chamber is cooled by refrigerant, which evaporates in the copper cooling coil wound externally around the chamber. The thermo expansion valve (item2) provides excellent performance to the system. The compressor (item1) is a high-capacity, air-cooled, hermetically sealed unit.

A suction-line accumulator (item 3) in the return line from the cooling-coil to the compressor prevents slugs of liquid refrigerant, which might cause damage, from reaching the compressor.

A filter dryer (item 4) in the line between the liquid receiver (item 5) and the expansion valve absorbs any residual particulate and water contamination in the system. The filter dryer does not need to be serviced or replaced.

The electrical fan (item 6) simultaneously cools down the condenser coil (item 7) and the compressor.

See Section 2.2 on page 12 for refrigerant type and charge.

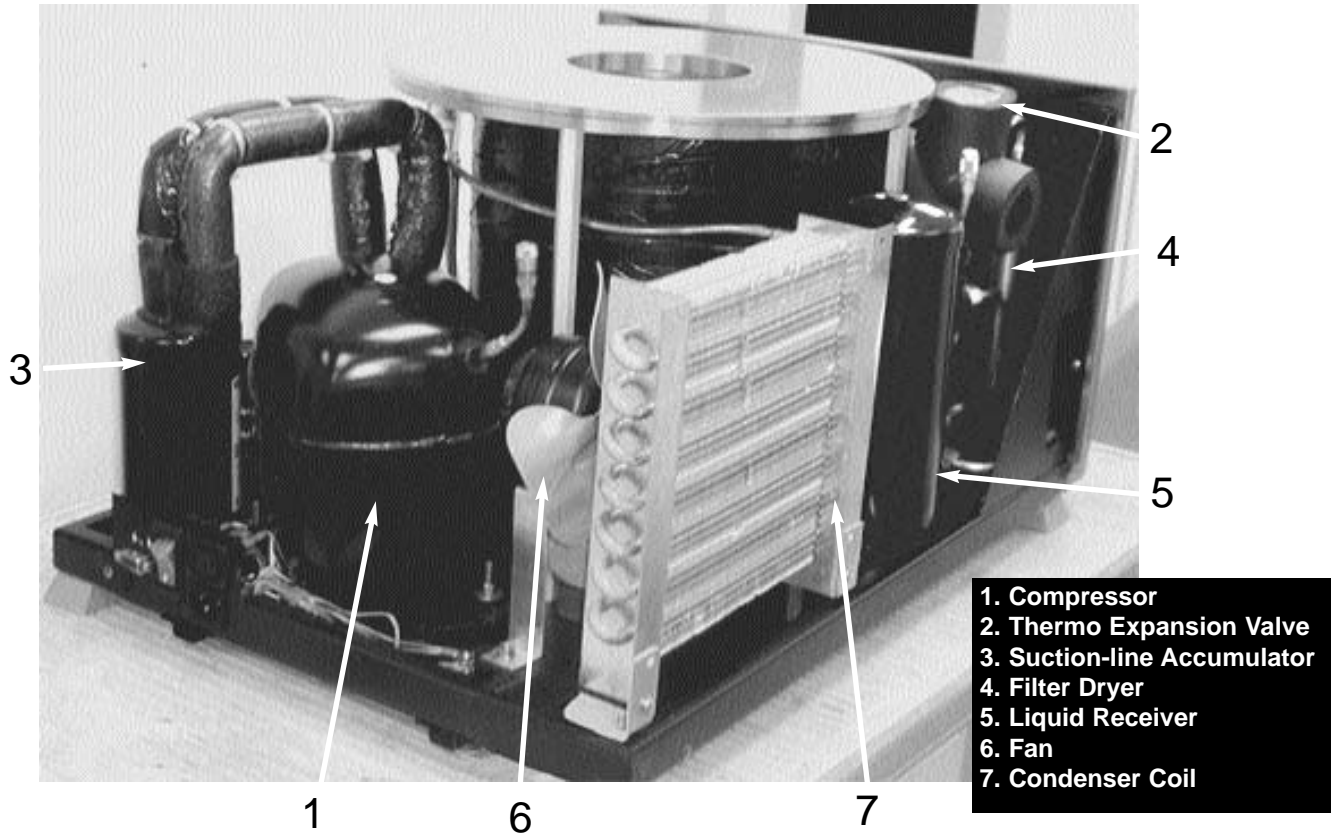

Figure 3 – INSIDE MODULYOD

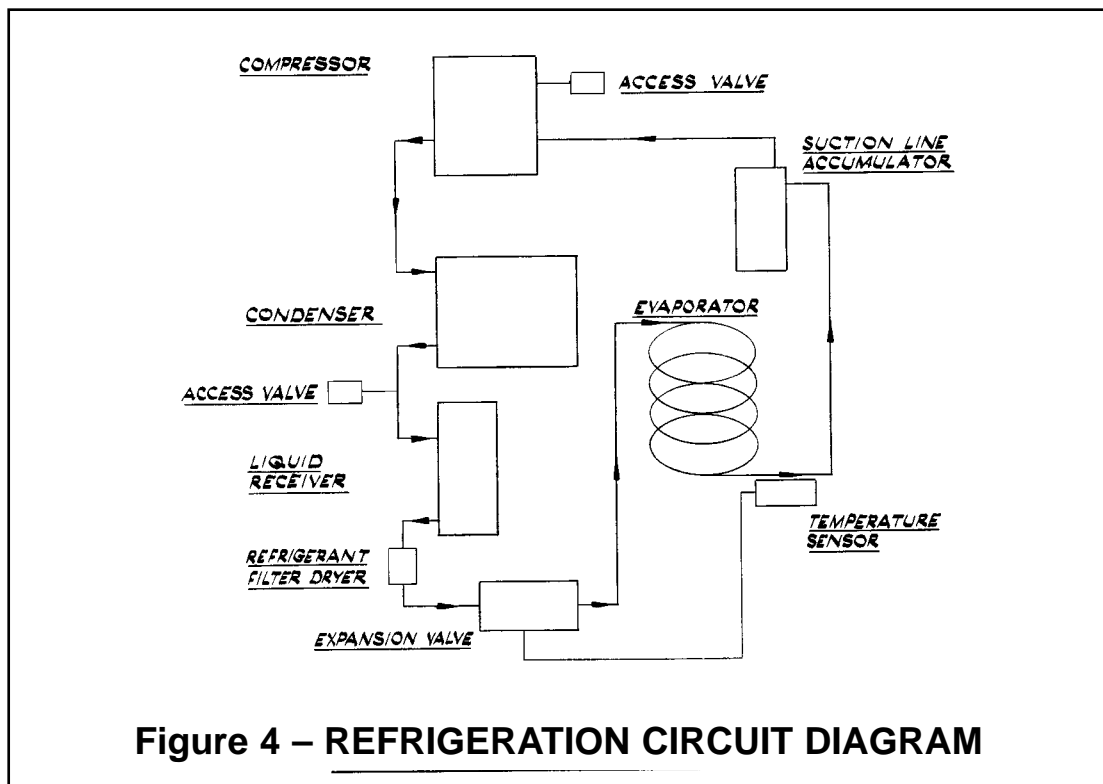

Figure 4 – REFRIGERATION CIRCUIT DIAGRAM

1.2.1.3 USER INTERFACE

The user interface is a membrane panel with two indicator bars, two digital displays and two pushbutton actuators. It is located on the upper sloping surface of the front fascia of the ModulyoD. Through this interface the user will switch on and off and moving refrigeration and vacuum. Figure 5, Figure 2 and Table 1 (below) locate and describe, in detail, the function of each item.

Table 1 – CONTROL PANEL DESCRIPTION

Control	Figure #	Item #	Use
Fridge button	5	1	To switch refrigeration system on and off.
Fridge On lamp	5	2	The lamp is on when the refrigeration system is on.
Temperature display	5	3	To show temperature of the condenser chamber in °C. When the temperature of the condenser chamber is equal to or higher than ambient temperature, 'rt' is displayed, which stands for 'room temperature'.
Temperature progress	5	4	The temperature indicator bar is a multicolored display designed to indicate operating status from a distance. Green indicates a temperature at or near minimum (approximately -40 °C.). Amber bars indicate temperatures progressing from approximately -40° to -7°. Red bars indicate temperatures progressing from -7° to ambient (see Figure 6, page 8).
Vacuum pump button	5	5	To switch vacuum pump on and off if the pump is plugged into auxiliary power outlet of the ModulyoD (see Section 3.5, page 15).
Vacuum progress bar	5	8	The lamp is on when the vacuum pump is on.
Vacuum pump on lamp	5	6	To show absolute pressure in the condenser chamber. Readings start when pressure is less than 50 mbar and are in millibars down to 1.0 millibar. When the vacuum pressure drops below 1.0 millibar, the pressure will then be displayed in micro-bars. When pressure is above 50 mbar, 'Hpr' is displayed, which stands for 'High pressure'.
Vacuum level display	5	7	The vacuum indicator bar is a multicolored display designed to indicate operating status from a distance. Green indicates a pressure at or below 1mbar. Amber bars indicate pressures progressing from approximately 1 to 13 mbar. Red bars indicate pressures progressing from 13 to 52 mbar, (see Figure 7, page 8).
Mains switch with circuit breaker	2	4	To switch the ModulyoD on and off.

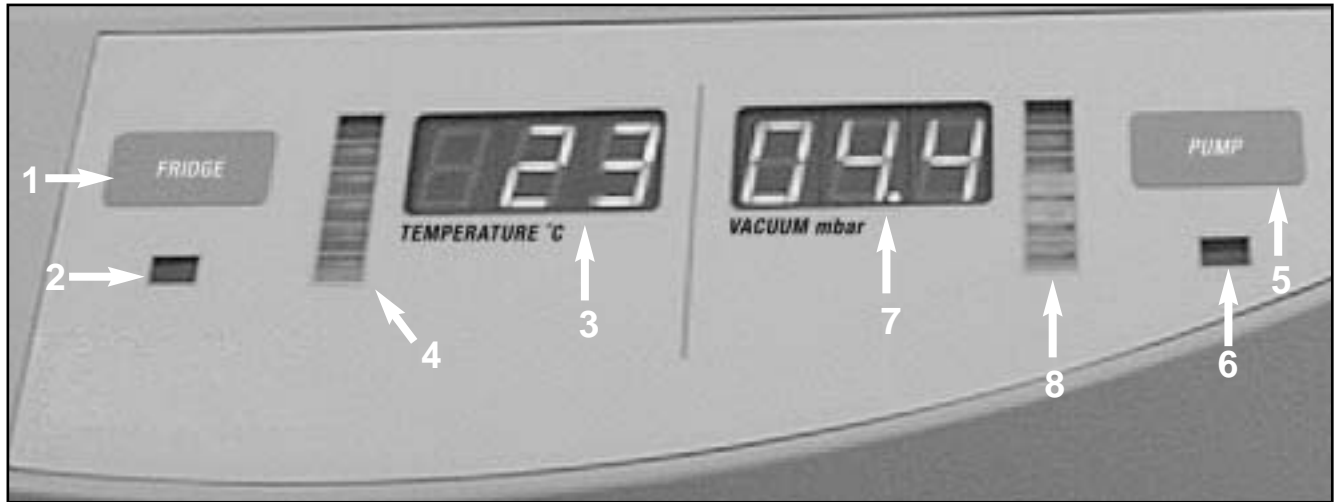
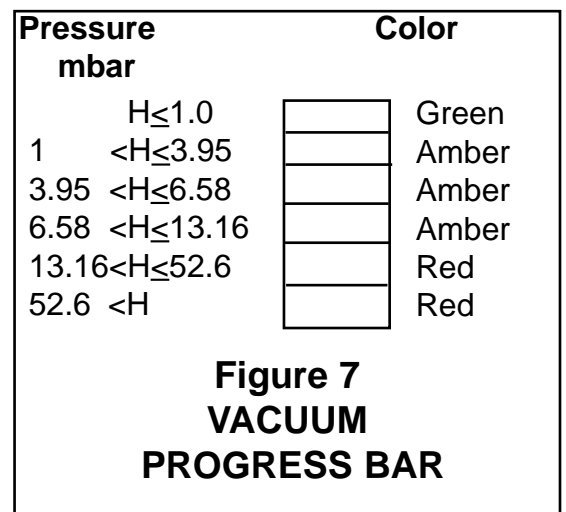
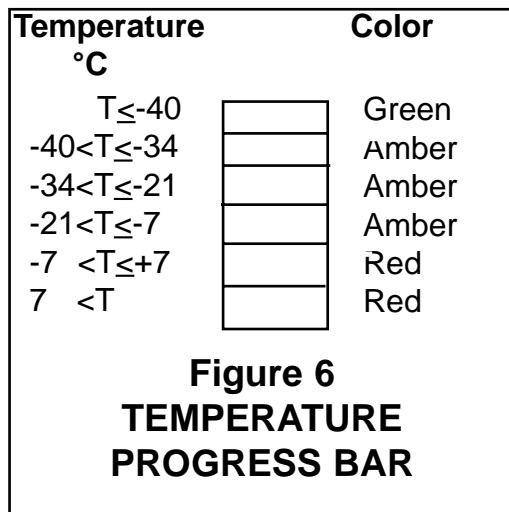

Figure 5 – MODULYO D CONTROL PANEL
See Table 1, page 7, for description of items.



1.2.1.4 FRONT FASCIA

The front fascia forms the front of the ModulyoD cabinet. The user interface is located on the upper right-hand portion of this surface. The drain outlet, drain valve and vacuum port are located on the lower left-hand portion.

1.2.1.5 CONNECTIONS

Figure 1 (Page 4) and Table 2 locate and describe, in detail, the function of the drain outlet, drain valve and vacuum port. Figure 2 and Table 2 locate and describe the electrical connections.

Connection	Figure #	Item #	Use
Vacuum port	1	7	To connect your vacuum pump to the ModulyoD
Drain valve	1	6	Close the valve (turn it fully clockwise) to isolate the condenser chamber from the drain outlet. Open the valve (turn it anti-clockwise) to admit air into the vacuum system, and to drain water from the condenser chamber after it has been defrosted.
Drain outlet	1	5	This outlet is used to drain water from the ModulyoD during defrosting of the condenser chamber. The outlet is also used to admit air into the vacuum system.
Power IEC 320 inlet	2	1	To connect the ModulyoD to an external power source.
Auxiliary power	2	2	To connect your vacuum pump to the IEC 320 outlet power supply which will enable the pump to be operated directly from the ModulyoD.
RS232 port	2	3	To connect the ModulyoD to a computer or chart recorder.

1.2.1.6 CONDENSER EXTENSION ASSEMBLY

The ModulyoD is shipped with the condenser extension assembly installed (see Figure 8). This extension assembly is necessary to prevent the formation of ice in the vacuum pump connection. The extension assembly should only be removed when working with the Spin Freezer 96 freeze drying accessory (part numbers F05637000 or F05637115).

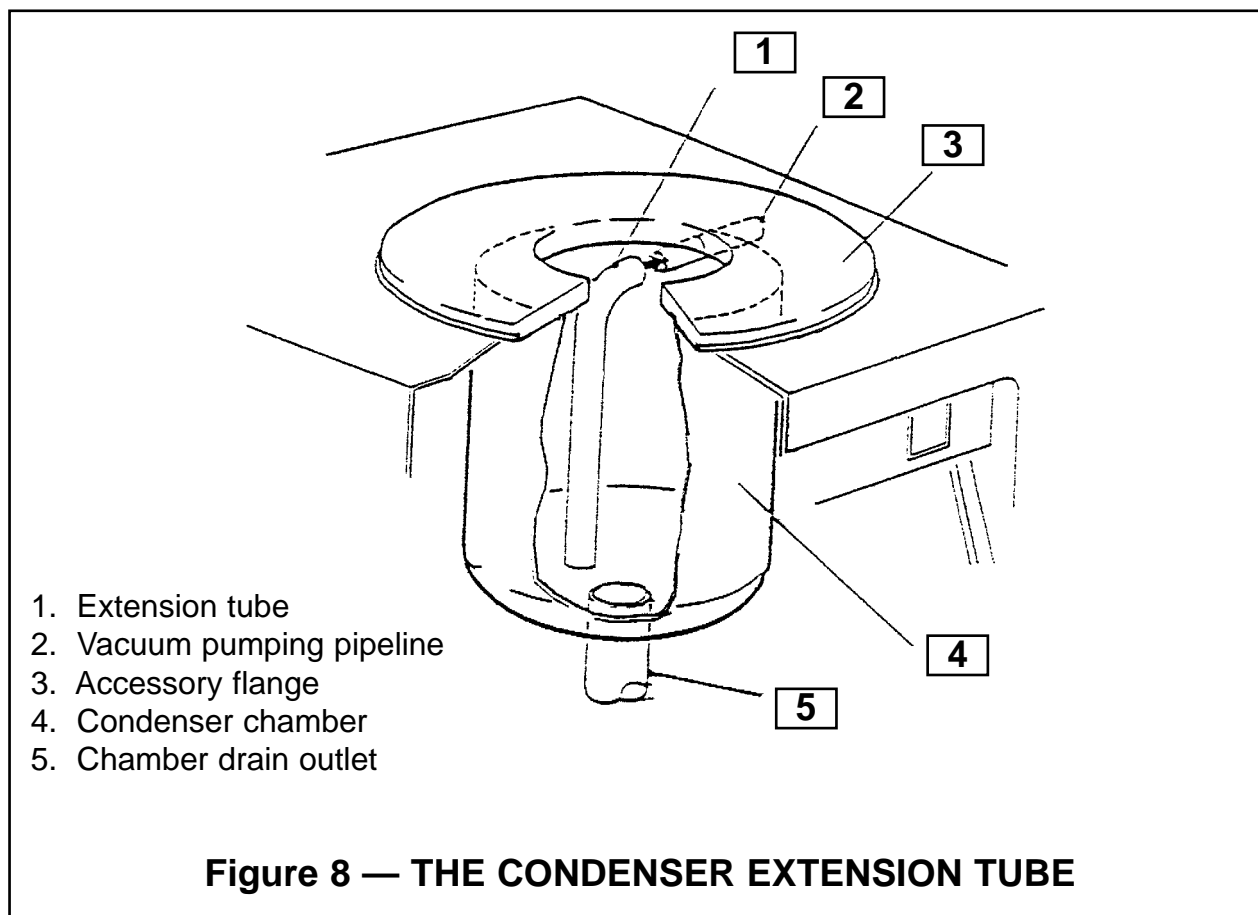

1.3 PROTECTION DEVICES

The ModulyoD and vacuum pump, if connected to the auxiliary power outlet, are protected by a circuit breaker built in to the mains power switch. You must manually reset the switch whenever the circuit breaker is activated. (Please refer to Section 2.3 for electrical requirements).

1.4 APPLICATIONS

1.4.1 INTRODUCTION

For freeze drying applications, the ModulyoD must be connected to a two-stage vacuum pump and fitted with a drying accessory (see Section 6.0 for a list of optional freeze drying accessories.) Optimal freeze drying conditions are normally determined empirically. For this reason, we recommend the user keep a detailed log of operating parameters (see Appendix C, Freeze Drying User's Log). ModulyoD performance data may be collected by connecting a computer to the RS232 port (See Figure 2). The following sections contain general information on some of the factors that affect the freeze drying process.

1.4.2 THE FREEZING PROCESS

You must pre-freeze the sample before placing it in (or on) the drying accessory. The thickness of the ice (and, hence, the sample) will affect the length of time needed to dry a given sample. In general, the thickness should be less than 10 mm.

1.4.3 THE DRYING PROCESS

When the condenser chamber has reached a temperature of $-40\text{ }^{\circ}\text{C}$ (as shown on the temperature display), the vacuum pump may be switched on (see Section 4). The pressure in the condenser chamber then starts to drop, producing the conditions necessary for freeze drying to occur. The pressure display will show the pressure in the condenser chamber.

The time required to dry sample varies and is determined by a number of factors: The type of sample, sample mass and thickness, type of container used, temperatures of the sample, and the condenser and system performance.

Freeze drying requires an input of heat energy to the sample to change the ice into water vapor. When using the ModulyoD, this energy may be absorbed solely from the surroundings or, alternatively, a heated accessory may be used to provide additional energy input. If using a heated accessory, the accessory should not be switched on until the pressure in the condenser chamber has fallen to 1 mbar or lower.

When deciding on the quantity of heat input required, or when you try to optimize the drying cycle for a particular product, it is important to observe the physical appearance of the product whenever possible during the drying process. If the product has been correctly frozen, it will usually appear to be uniform in color and compact. If the product is uneven in color, or if signs of boiling are visible, then the product may have been incorrectly frozen, or may have undergone some physical change, possibly from the application of too much heat.

A wide range of factors have to be considered when trying to optimize the drying cycle for a given sample. To assist in this optimization, we, therefore, recommend taking note of the rate of change of both temperature and pressure within the condenser chamber (see Appendix C) during the freeze drying process.

1.4.4 VAPOR TRAPPING

When the ModulyoD is used as a vapor trap (for example, in gel drying applications), its function is significantly different than that when it is used in freeze drying applications. In vapor trapping applications, the ModulyoD acts solely to protect the vacuum pump; in freeze drying applications, it actually pumps the water vapor from the product. In vapor trapping applications, it is often necessary to limit the vapor flow from the system to the ModulyoD by fitting a restrictor between the vapor source and the ModulyoD. The size of restrictor required depends on the system. See Appendix A for detailed information on the use of the ModulyoD as a vapor (cold) trap.

2.0 TECHNICAL DATA

2.1 GENERAL

Dimensions: height x width x depth	332 x 595 x 695 mm 13.1 x 23.4 x 27.4 in
Accessory-flange diameter	370 mm/14.6 in
Mass	45 kg, (100 lb)
Ambient operating temperature range	5 to 24 °C
Maximum ambient storage temperature	50 °C
Condenser chamber	
Ice capacity in 12 hours	1.2 kg (2.6 lb)
Maximum ice capacity	4.5 kg (9.9 lb)
Operating temperature	-50 ± 5 °C
Surface area	0.15m ² (233 in ²)
Volume	7.21ℓ
Average evaporation rate	95 cm ³ h ⁻¹
Instrumentation	
Temperature display range	-60 °C to ambient
Vacuum display pressure range	10 microbar to 50 millibar

2.2 REFRIGERATION SYSTEM

Refrigerant type	ISCEON 69 L
Refrigerant charge	0.68 kg (1.5 lb)
Thermocouple type	Type T

2.3 ELECTRICAL DATA

	MODULO D-230	MODULO D-115
Nominal electrical supply	220 to 240 V, 1-phase	110V, 1-phase
Electrical supply frequency	50 Hz	60 Hz
Power rating		
Protection		
Internal	8 amp	15 amp

2.4 CONSTRUCTION DETAILS

2.4.1 LEGISLATION AND STANDARDS

The ModulyoD has been designed in compliance with the following legislation and standards:

- CE Directives

2.4.2 CONSTRUCTION MATERIALS

Item	Material
Cabinet	Steel
Condenser chamber	Stainless steel
Vacuum pipeline	Stainless steel
Condenser extension-tube	PVC

2.5 VACUUM PUMP REQUIREMENTS

Note: Your vacuum pump must have a gas-ballast facility to prevent water build up in the pump.

For freeze drying, your vacuum pump must meet the following specification:

Type of pump	Two-stage, oil-sealed rotary pump
Ultimate pressure	1×10^{-2} to 3×10^{-2} mbar (1 to 3 Pa)
Pumping rate	50 ℓ/min or more
Recommended pump	Thermo Electron LyoPump™

3.0 INSTALLATION

WARNING: Use proper lifting technique to lift ModulyoD.

3.1 UNPACK AND INSPECT

Remove all packing and inspect the ModulyoD. If the ModulyoD is damaged, notify your supplier and the carrier in writing within three days; state the Serial Number of the ModulyoD together with your order number, and your supplier's invoice number. Retain all packing materials for inspection. Do not use the ModulyoD if it is damaged.

Check that your package contains the items listed in Table 3, below. If any of these items are missing, notify your supplier in writing within three days.

Qty	Description	Check ✓
1	ModulyoD Freeze Dryer	<input type="checkbox"/>
1	Power cord	<input type="checkbox"/>
1	Power cord for pump	<input type="checkbox"/>
1	Instruction Manual	<input type="checkbox"/>

Table 3 - Checklist of components

If the ModulyoD is not to be used immediately, replace the protective cover on the accessory flange. Store the ModulyoD in a clean, dry area until ready for use.

3.2 SITE PREPARATION

The ModulyoD is designed for use on a laboratory benchtop. Locate the ModulyoD in its required operating position, within convenient access to a suitable electrical supply.

We recommend leaving an air-gap of at least 200 mm (8 in) between all four sides of the ModulyoD and any wall or obstruction. If you do not leave a sufficient air-gap, poor cooling of the ModulyoD may result in poor performance. When locating the ModulyoD, consider ease of access for maintenance and repair work, which may require removing the cover of the ModulyoD.

3.3 CONNECT THE MODULYO D TO THE ELECTRICAL SUPPLY

WARNING: Ensure that the electrical installation of the ModulyoD conforms with your local and national safety requirements. It must be connected to a suitably fused and protected electrical supply and a suitable earth (ground) point.

1. Make sure that the ModulyoD is suitable for use with your electrical supply voltage and frequency.
2. Locate the standard 2 meter long power cord IEC 320 plug and outlet supplied with the ModulyoD.
3. Connect a 15 A fuse/breaker at the electrical supply outlet to protect the ModulyoD.

3.4 CONNECT THE VACUUM PUMP

WARNING: If intending to freeze dry product containing sodium azide, make sure that the vacuum pump and pipeline are suitable for freeze drying these products. If they are not suitable, there is a severe risk of explosion.

CAUTION: A two-stage vacuum pump must be used with the ModulyoD. If not, the pump will have a very short working life.

Connect the vacuum pump to the vacuum pump connector on the front of the ModulyoD (Figure 1, item 7). The connector is suitable for use with a 10 mm inside diameter pipeline.

We recommend the use of a Thermo Electron LyoPump™ high vacuum pump with the ModulyoD. These pumps are suitable for freeze drying products which contain sodium azides.

If you do not use a Thermo Electron vacuum pump, the pump must meet the requirements specified in Section 2.5. To connect another type of pump to the ModulyoD, refer to the instruction manual supplied with the pump.

3.5 CONNECT A VACUUM PUMP TO THE MODULYO D

If you have a Thermo Electron high vacuum pump, use the following procedure to connect the pump to the ModulyoD. Otherwise, you may order the additional connection kit, which consists of NW25 nozzle connector (item 5, Figure 9) and NW25 clamp (item 7, Figure 9). After having the additional kit installed on your pump, follow the same procedure below.

1. Remove the vacuum pump connection kit, which is already pre-assembled, from its packing material.
2. Push the elbow (item 2, Figure 9) of the connection kit onto the vacuum port of the ModulyoD (item 1, Figure 9).
3. Push the other end of the connection kit onto the nozzle connector of the vacuum pump. It is recommended that you use the ModulyoD (which has an IEC 320 outlet on the rear part of the unit (item 2, Figure 2) as a power supply for our vacuum pump, using the power cord supplied with the ModulyoD. This will enable operation of your vacuum pump directly from the ModulyoD control panel.

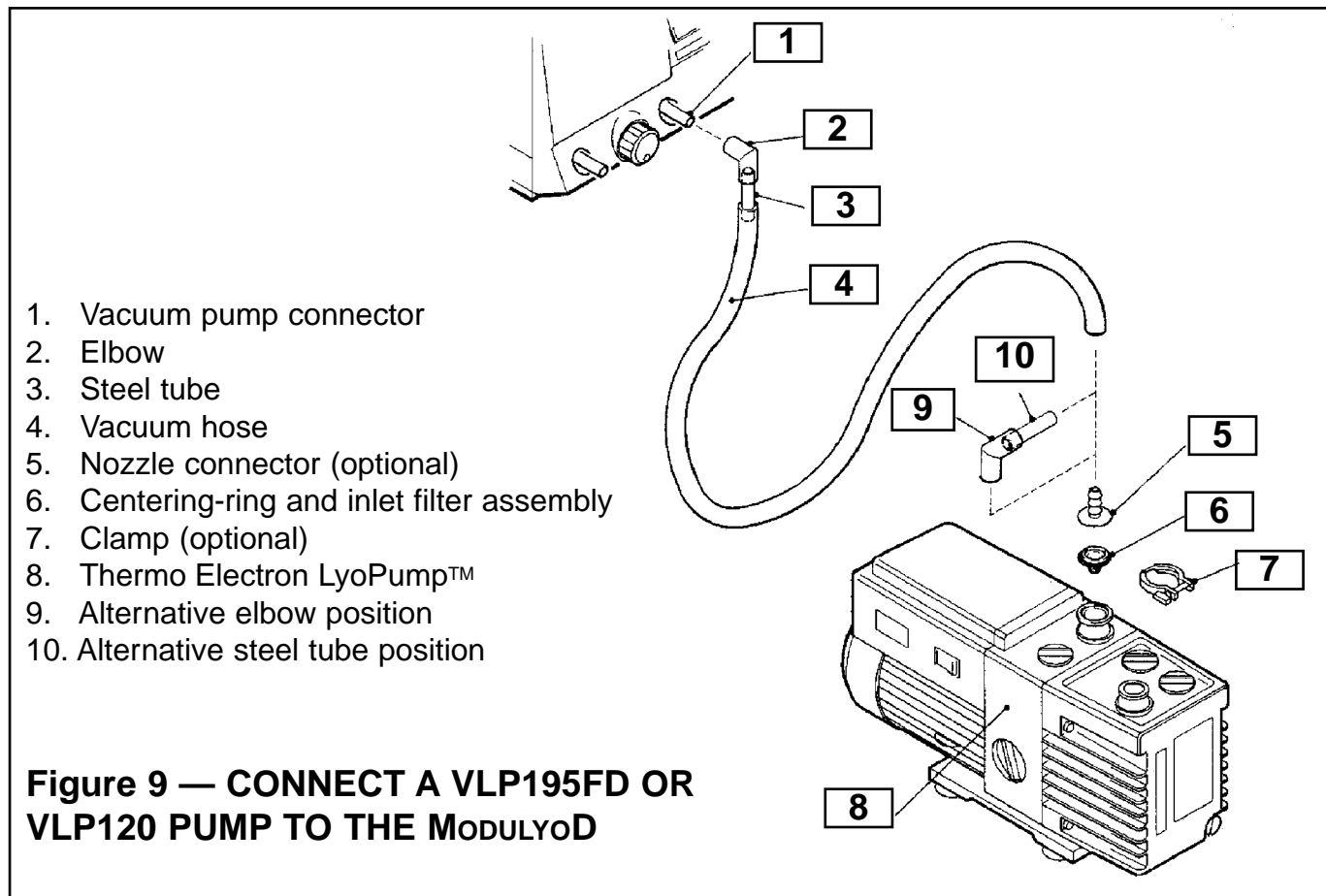

3.6 PUMP OUTLET SAFETY

Fit an oil mist filter or pipe the exhaust gases of the vacuum pump to a chemical fume hood.

All Thermo Electron high vacuum pumps are supplied with a gas ballast oil return kit (GBORK) and EMF10 oil mist filter. Refer to specific manuals received with your Thermo Electron pump to install these items.

3.7 TEST AFTER INSTALLATION

WARNING: Never engage the vacuum pump when water is present in the Ice Condenser. The introduction of water directly into the internal mechanism of the vacuum pump will cause significant damage to the pump.

CAUTION: Do not attempt to use the ModulyoD if it fails the installation test. If you do, poor performance may result in the loss of the sample being freeze dried.

Use the following procedure to test the ModulyoD:

If any of the checks below fail, turn the mains switch (item 4, Figure 2) off, then switch off the external electrical supply and disconnect the supply from the ModulyoD. Contact your supplier for advice. Do not attempt to use the ModulyoD.

3.7 TEST AFTER INSTALLATION (cont'd)

1. Ensure that the main switch (item 4, Figure 2) is in the '0' (off) position.
2. Connect the ModulyoD to the electrical supply and turn on the main switch (item 4, Figure 2). The controls on the control panel (item 3, Figure 1) should be illuminated.
3. Turn on the refrigeration system of the ModulyoD by pressing 'Fridge' button (item 1, Figure 5). The 'Fridge On' lamp (item 2, Figure 5) should go on.
4. Watch the cooling fan (item 6, figure 3) through the grill on the rear of the ModulyoD. The fan should rotate.
5. Check that the compressor operates. There should be a low "hum" from the compressor.
6. Leave the refrigeration system operating. In a minute or two, check the temperature on the temperature display (item 3, Figure 5). The displayed temperature should be falling.
7. Check the temperature of the condenser chamber in approximately 40 minutes. The temperature should be at or below -45 °C with an ambient temperature of 24 °C or less . Check that green light on the temperature progress bar (item 4, Figure 5) is illuminated.
8. Attach any empty drying accessory to the accessory flange of the condenser chamber (item 1, Figure 1). Refer to Section 6.0 for optional accessories.
9. Turn the drain valve (item 6, Figure 1) fully clockwise to close it and then switch on the vacuum pump.
10. Leave the vacuum pump on while watching the vacuum level display (item 7, Figure 5). The readings on the display should change from 'Hpr' to the actual pressure in the condenser chamber within a few minutes. As time goes by, the pressure should continue to fall.
11. Check the pressure in about 30 minutes. The pressure should be less than 70 microbars.

If the ModulyoD has passed through all these steps, it is ready for use. Refer to Section 4 on operation.

4.0 OPERATION

4.1 SAFETY

WARNING: If you intend to freeze dry products containing sodium azide, be sure that your vacuum pump and pipeline are suitable for freeze drying these products. If they are not suitable, there is a severe risk of explosion.

Sodium azide is sometimes used as a stabilizing agent in freeze drying processes. Sodium azide is toxic and, when dry, is highly explosive.

If you freeze dry a product containing sodium azide, a chemical reaction can occur in the presence of heavy metals such as copper, lead, zinc, and cadmium. The result of this reaction is the formation of metallic azides, which are highly unstable and explosive.

The ModulyoD contains no heavy metals and is suitable for freeze drying products containing sodium azide. The Thermo Electron LyoPump™ high vacuum pumps are also suitable for this purpose.

If you do not use a Thermo Electron pump, your vacuum pump and vacuum pipeline may not be suitable for freeze drying products containing sodium azide. Check with your vacuum pump manufacturer to determine its suitability if you intend to freeze dry products containing sodium azide.

4.2 SEQUENCE OF OPERATION

Operation of the ModulyoD can involve a number of different steps, as shown in Table 4 below:

Operation step	Refer to Section
Prepare the ModulyoD	4.3
Fit the sample container and other accessory	4.4
Pre-Cool the ModulyoD	4.5
Drying	4.6
Shut down	4.7

Table 4 — Sequence of operation

Before you freeze dry sample, always prepare the ModulyoD as described in Section 4.3. Always dry the sample and shut down the ModulyoD as described in Sections 4.6 and 4.7.

The order in which the remaining steps are carried out depends on the type of product container or other accessory used and the type of sample to be freeze dried. In some circumstances you will need to pre-cool the ModulyoD with the accessory flange open to the atmosphere; in other circumstances you will need to fit the sample container, pre-cool the ModulyoD and then load the sample.

If the correct sequence of operations to follow is not clear, refer to the instruction manual supplied with the sample container or other freeze drying accessory.

4.3 PREPARE THE MODULYO D

Note: Use only mild detergents to clean the condenser chamber, accessories and connecting pipeline. Some of the Thermo Electron accessories are made from acrylic materials and must not be cleaned with organic solvents.

Before you first use the ModulyoD, and between freeze drying cycles, prepare the ModulyoD, as follows (refer to Figure 1):

1. Turn the drain valve fully counterclockwise to open the valve and to remove any water left in the bottom of the condenser chamber. When the chamber is completely drained, turn the drain valve fully clockwise to close it.
2. If acidic or corrosive products have been processed, flush through the condenser chamber and drain outlet with clean water.
3. Make sure that the condenser chamber is dry.
4. Make sure the ModulyoD is clean, particularly the accessory flange. If the flange is not clean, you will not get a good vacuum seal and the performance of the ModulyoD will be poor.
5. Confirm that both the vacuum pump and the ModulyoD are properly connected to the interconnecting vacuum tubing.
6. Select a suitable drying accessory for the product. Wipe clean the sealing-ring of the accessory and check the sealing-ring for damage; if it is damaged, fit a new sealing-ring.

The accessory sealing-ring should not need lubricating.

4.4 FIT THE SAMPLE CONTAINER AND OTHER ACCESSORIES

A drying accessory may be connected to the ModulyoD accessory flange. Accessories have a rubber sealing-ring to seal the accessory to the ModulyoD accessory flange. Once positioned, the weight of the accessory is sufficient to produce an air-tight seal under vacuum conditions.

4.5 PRE-COOL THE MODULYO D

WARNING: Do not touch any part of the condenser chamber during or immediately after the cooling process. The condenser chamber is at a very low temperature and can cause tissue damage.

Note: If you cool the ModulyoD with no product in the chamber, the chamber temperature will cycle between approximately -40 °C and -55 °C.

4.5 PRE-COOL THE ModulyoD (cont'd)

Pre-cool the ModulyoD condenser chamber as follows:

1. Ensure that the displays on the control panel (item 3, Figure 1) are illuminated (that is, that the ModulyoD is connected to the electrical supply and the main switch [item 4, Figure 2] is on).
2. Press the 'Fridge' button. (item 1, Figure 5).
3. Leave the ModulyoD on until the temperature shown on the temperature display (item 3, Figure 5) is -45 °C or lower.
4. Wait an additional 10 minutes before operating.

4.6 DRYING

WARNING: Never engage the vacuum pump when water is present in the Ice Condenser. The introduction of water directly into the internal mechanism of the vacuum pump will cause significant damage to the pump.

CAUTION: Use the gas-ballast on the vacuum pump when drying. If you do not, water may condense in the pump.

1. On Thermo Electron high vacuum pumps, install the GBORK gas ballast oil return kit, referring to its instructions. On other pumps, fully open the gas-ballast valve (refer to the pump instruction manual).
2. Activate the pump "ON" by pressing 'Pump' button (item 5, Figure 5) if the pump is electrically connected to the ModulyoD vacuum pump power outlet (item 2, Figure 2).

Take note of the following when freeze drying products:

- Switch on a heated accessory only when the pressure is 1 mbar or less. (Green light on the vacuum progress bar is illuminated [(item 8, Figure 5)]).
- When a load is first applied to the ModulyoD, the temperature may rise for a few minutes. This is due to the high initial evaporation rate from the sample. If the temperature does not fall to ~-45 °C or below within a few minutes, the ModulyoD is overloaded. Reduce the amount of sample in the freeze drying system to prevent the sample from melting. When using the ModulyoD as a vapor trap, restrict the flow of vapor to the ModulyoD (for example, by using the pipeline attachment accessory [Appendix B, item 12]).
- If you wish to dry a number of flasks, first attach one flask, then evacuate the flask until the pressure (green light on the vacuum progress bar [item 8, Figure 5] is on) falls to 1mbar or less. Then attach and evacuate the remaining flasks in the same way.

4.6 DRYING (cont'd)

If you use this procedure, you can identify any flasks that might leak. This procedure also prevents rapid pressure increases, which might cause flasks to fall off of the drying accessory.

- If there appears to be a leak, check that the drain valve is fully closed and all seals are clean. If the ModulyoD continues to leak, contact your Thermo Electron distributor.

4.7 SHUT DOWN

CAUTION: If using a manifold assembly, do not admit air into the ModulyoD through the drain valve until all flasks have been removed, otherwise the flasks may fall off of the manifolds.

Look at the pressure shown on the pressure gauge and the appearance of the product and consult data gathered from previous freeze drying operations to determine when the freeze drying process has finished. Note that the pressure shown on the gauge will fall significantly when vapor is no longer being released from the sample.

Once the process has finished, shut down the ModulyoD as follows:

1. If you use a manifold accessory, use the manifold valves to vent each flask in turn. Remove and seal each flask.
2. Switch the vacuum pump off by pressing the 'Pump' button.
3. If you use other accessories, slowly open the drain valve to admit air to the system.
4. Remove the sample when the pressure shown on the pressure gauge has reached atmospheric pressure ('Hpr').
5. Press the 'Fridge' button to shut down the refrigeration system.
6. Remove the drying accessory.

4.8 DEFROST THE MODULYO D

WARNING: Do not touch any part of the condenser chamber during or immediately after the cooling process. The condenser chamber is at a very low temperature and may cause tissue damage.

WARNING: Do not pour water at a temperature greater than 50 °C into the ice condenser when it is cold. This may result in a dangerous rise in pressure in the refrigeration system.

Leave the ModulyoD switched off at ambient temperature to defrost. Make sure that all water is drained from the condenser chamber before you switch the ModulyoD “on” again. This method takes up to 36 hours to complete depending on the ambient temperature.

Alternatively, you can pour warm water into the ice condenser to speed up the defrosting process. This method is useful if you wish to use the ModulyoD again, immediately.

Use the following procedure:

1. Remove the drying accessory from the accessory flange.
2. Close the drain valve.
3. Pour warm water, at a maximum temperature of 50 °C, into the condenser chamber. *Note: Do not fill the chamber above the level of the vacuum pipeline (item 2, Figure 8).*
4. Wait for a few minutes to allow the ice to melt.
5. Fully open the drain valve and allow the water to drain out of the condenser chamber. A piece of tubing can be connected to the drain outlet for easier drainage into a sink or a container.
6. Remove the condenser extension tube (item 1, Figure 8). Clean and dry both the extension tube and the inside of the condenser chamber.
7. Re-fit the condenser extension tube.

Prepare the ModulyoD for the next operational cycle as described in Section 4.3.

4.9 OPERATION WITH NO LOAD

If operating the ModulyoD with no load for several hours, the internal components of the ModulyoD get very cold. Atmospheric water vapor will then condense onto the cold surfaces and may drip out of the bottom of the ModulyoD. You may, therefore, see puddles of water under the ModulyoD, which give the impression that water is leaking from the condenser chamber.

If you see water dripping out of the ModulyoD, inspect the condenser chamber. If there is ice in the chamber, the water is probably not leaking from the chamber, but is dripping from the cold surfaces inside the ModulyoD. Always check this carefully before contacting your supplier.

To avoid this problem, we recommend shutting down the ModulyoD if not using it for more than three or four hours. This is particularly important if you use the unit in a high humidity environment.

5.0 MAINTENANCE

Note: You must follow the maintenance procedures defined in the instruction manuals supplied with your accessories and vacuum pump.

The following sections describe possible problems and their possible solutions, and are intended as a guide to the user and to qualified service engineers. Some of the solutions may be carried out by the user, but others (which are clearly identified) must be carried out only by approved Thermo Electron service engineers.

5.1 SAFETY

WARNING: Obey the safety instruction given below and take note of appropriate precautions. If you do not, you may cause injury and damage to equipment.

5.2 PRECAUTIONS

- Switch off the ModulyoD, isolate it from the electrical supply, and defrost it before starting maintenance.
- Do not touch any part of the condenser chamber during or immediately after the cooling process. The condenser chamber is at a very low temperature and may cause tissue damage.
- Do not pour water at a temperature greater than 50 °C into the condenser chamber when it is cold. If you do, this may result in a dangerous pressure rise in the refrigeration system.
- Ensure that any fault finding is done in a well-ventilated area.
- After you have rectified a fault, ensure that the electrical installation of the ModulyoD conforms with your local and national safety requirements. It must be connected to a suitably fused and protected electrical supply and a suitable earth (ground) point.

5.3 REFRIGERANT LEAKS

The refrigerant used in the ModulyoD is heavier than air and is an asphyxiant by the displacement of oxygen. If a refrigerant leak is suspected, place the unit in a well-ventilated area. Do not allow naked flames or smoking near the ModulyoD, as products of combustion of the refrigerant include dangerous fluorides and chlorides.

If refrigerant vapor is inhaled, summon medical help immediately. Take the victim to a well-ventilated, uncontaminated area. If the victim's breathing is weak or has stopped, call for medical attention, apply artificial ventilation, preferably using an oxygen resuscitator. Do not use adrenaline or other cardiac stimulants.

At normal atmospheric pressure, the refrigerant will evaporate at -40 °C. Contact with skin or eyes can cause cold burns. If contact has taken place, seek medical help immediately and carry out the following: Remove clothing from the affected area; carefully irrigate the affected area with tepid water for at least 15 minutes; apply a sterile dressing and treat the wound as you would a heat burn.

6.0 ACCESSORIES

DRYING ACCESSORIES (Appendix B, p. 26)

Accessory	Item #	Catalog #
8-port column manifold	1	F05656000
16-port drum manifold	2	F05628000
24-port drum manifold	3	F05621000
24-port column manifold	4	F05622000
Bell Jar	5	F02960000
VC45 Vial Cell Stoppering shelf unit	6	F05623000
Heater kit for VC45/Stoppering Shelf-115VAC 60Hz	7	F05655115
Heater kit for VC45/Stoppering Shelf-230VAC 50Hz	8	F05655000
Spin Freezer 230V/50Hz	9	F05637000
Spin Freezer 115V/60Hz	10	F05637115
Secondary drying manifold, basic single column	11	F02964000
Secondary drying manifold, additional single column	11	F02956000
Secondary drying manifold, double column	11	F02965000
Pipeline attachment	12	F05660000
Acrylic cylinder	13	F05652000
Acrylic lid	14	F05632000
Rack Assembly	15	F05629000
Product Tray	16	F05630000
Heater Mat	17	F05631000
Temperature Controller-115V/60Hz	18	F05633115
Temperature Controller-230V/50Hz	19	F05633000
Specimen Dryer	20	F02910000
Adapter Flange	21	F05626000
Isolation Valve	22	F05643000

7.0 WARRANTY AND LIABILITY

Thermo Electron freeze drying products (except glassware) are warranted against defects in material and workmanship for one year after the date of delivery to the original purchaser. Thermo Electron's warranty is limited to defective materials and workmanship, and does not cover incidental or consequential damages. Warranty work is the responsibility of the distributor. The warranty obliges you to follow the precautions in this manual. It is the responsibility of the user to dispose of ALL materials in a manner in accordance with all federal, state and local regulations. ALL RETURNED UNITS MUST BE DECONTAMINATED AND FREE OF RADIOACTIVITY. Under no circumstances shall Thermo Electron be liable for damages due to the improper handling or use of its products. Thermo Electron assumes no liability, express or implied, for your use of this equipment.

Appendix A

Using the ModulyoD as a cold trap

Scope

By utilizing the pipeline adapter accessory, the ModulyoD may be used as a low temperature vapor trap for a variety of devices. These include vacuum concentrators, rotary evaporators and vacuum ovens.

CAUTION: Do not attempt to connect vacuum devices directly to the isolation valve on a column or drum manifold. Caustic vapors may damage the rubber portion of the isolation valve and discolor or corrode the manifold.

CAUTION: The ModulyoD is suitable for use with most organic solvents. It is not recommended for use with acids.

Installation

The pipeline adapter (Appendix B, item 12) is positioned directly over the stainless steel accessory flange with the long end of the pipeline adapter extending down into the condenser chamber. The rubber gasket surrounding the flange on the pipeline adapter forms the vacuum seal with the accessory flange on the top of the ModulyoD. Once in position, vacuum tubing from the desired device is connected to the pipeline adapter and secured with a hose clamp. The vacuum hose connecting the ModulyoD to the vacuum source is connected in the manner described in Section 3.4.

Operation

The ModulyoD must be pre-cooled to operate as a vapor trap. The fridge button must be switched on and the temperature progress display must be in the green range. Switch on the vacuum source and begin to monitor the vacuum progress display. This indicator should gradually progress from a reading of 'Hpr' to green as the vacuum pressure drops.

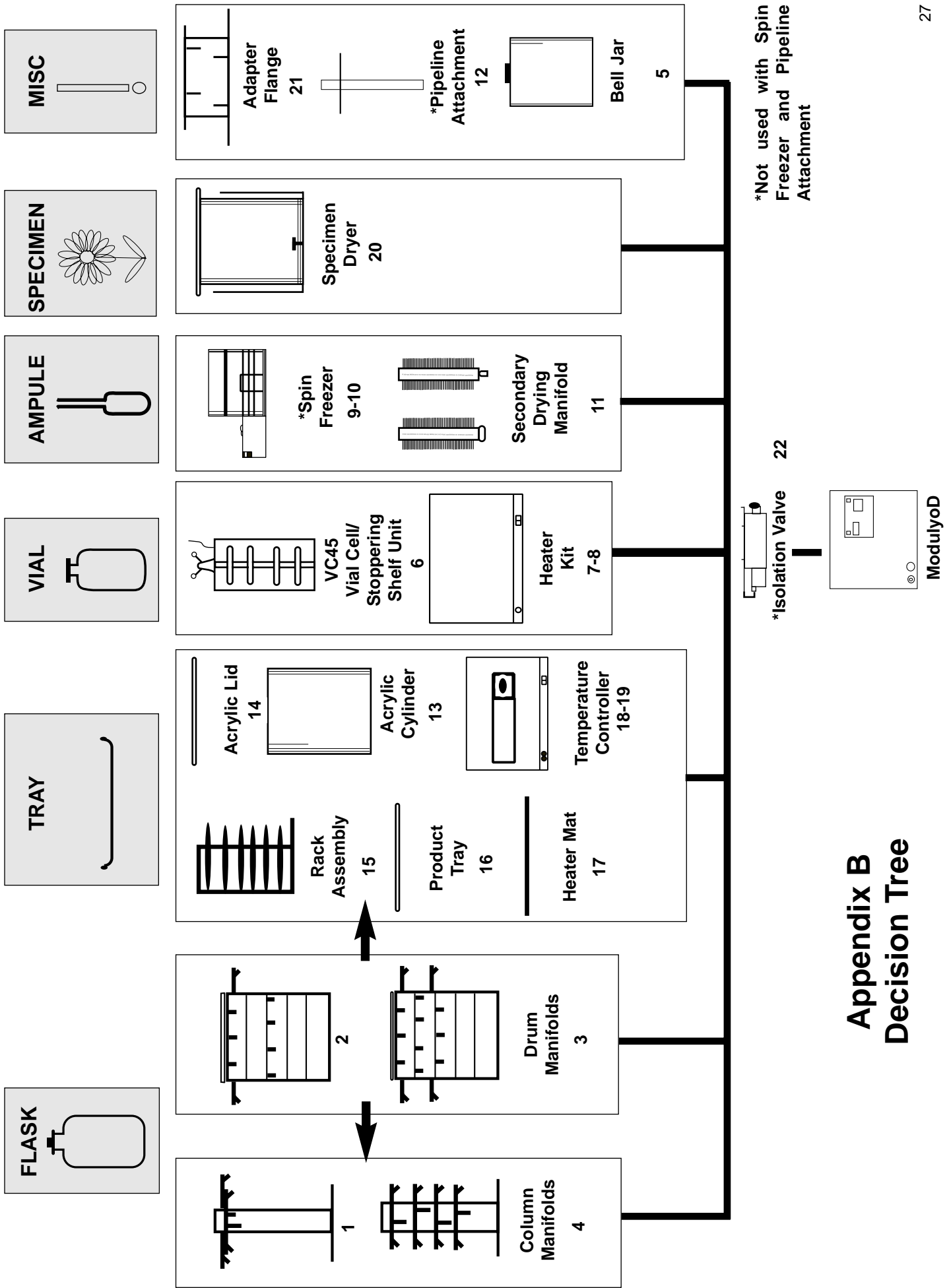

Appendix B Decision Tree

Thermo Electron Corporation

Bioscience Technologies

450 Fortune Boulevard
Milford, MA 01757
866.9.THERMO (866.984.3766) • Fax: 508.634.2199
www.thermo.com

Laboratory Pipetting and Consumables

info.pipettes@thermo.com

Molecular Biology

info.molbio@thermo.com

Microplate Instrumentation

info.microplateinstruments@thermo.com

Sample Preparation

info.sampleprep@thermo.com

Laboratory Automation & Integration

info.labautomation@thermo.com

New Labs

newlabs@thermo.com

Controlled Environment

info.controlenv@thermo.com

Services

services.biosciencetech@thermo.com

Bioscience
Technologies

International Sales Office Locations

Belgium

Brussels
+32 2 482 30 30
Fax: +32 2 482 30 31

France

Cergy Pontoise Cedex
+33 1 34 32 51 51
Fax: +33 1 34 32 51 59

Germany

Dreieich
+49 6103 408 0
Fax: +49 6103 408 1222

Netherlands

Breda
+31 76 571 4440
Fax: +31 76 587 9757

Russia

Saint-Petersburg
+7 812 325 8045
Fax: +7 812 186 1194

Moscow

+7 095 755 9045
Fax: +7 095 755 9046

Spain

Barcelona
+34 93 2233154
Fax: +34 93 2230857

Sweden

Stockholm
+46 8 742 03 90
Fax: +46 8 742 09 47

Lund

+46 46 90 96 60
Fax: +46 46 32 87 70

United Kingdom

Basingstoke, Hampshire
+44 01256 81782
Fax: +44 01256 81792

China

Beijing
+8610 5850 3588
Fax: +8610 6621 0847

Shanghai

+8621 5465 7588
Fax: +8621 6445 7830

Hong Kong

Wanchai
+852 2885 4613
Fax: +852 2567 4447

India

Bangalore
+91 22 2778 1101
Fax: +91 22 2778 1103

Japan

Yokohama-City
+81 45 453 9122
Fax: +81 45 453 9222

Thermo
ELECTRON CORPORATION

© 2001-2003 Thermo Electron Corporation, All rights reserved.
Thermo Electron Corporation, SpeedVac, and Analyze, Detect, Measure,
Control, are trademarks of Thermo Electron Corporation.