



# STANDARD OPERATING PROCEDURES

SOP: 1701  
PAGE: 1 of 14  
REV: 0.1  
DATE: 07/27/95

## SUMMA CANISTER SAMPLING

### CONTENTS

- 1.0 SCOPE AND APPLICATION
- 2.0 METHOD SUMMARY
- 3.0 SAMPLE PRESERVATION, CONTAINERS, HANDLING, AND STORAGE
- 4.0 INTERFERENCES AND POTENTIAL PROBLEMS
- 5.0 EQUIPMENT/APPARATUS
  - 5.1 Subatmospheric Pressure Sampling Equipment
  - 5.2 Pressurized Sampling Equipment
- 6.0 REAGENTS
- 7.0 PROCEDURES
  - 7.1 Subatmospheric Pressure Sampling
    - 7.1.1 Sampling Using a Fixed Orifice, Capillary, or Adjustable Micrometering Valve
    - 7.1.2 Sampling Using a Mass Flow Controller/Vacuum Pump Arrangement (Andersen Sampler Model 87-100)
  - 7.2 Pressurized Sampling
    - 7.2.1 Sampling Using a Mass Flow Controller/Vacuum Pump Arrangement (Andersen Sampler Model 87-100)
- 8.0 CALCULATIONS
- 9.0 QUALITY ASSURANCE/QUALITY CONTROL
- 10.0 DATA VALIDATION
- 11.0 HEALTH AND SAFETY
- 12.0 REFERENCES
- 13.0 APPENDICES
  - A - Volatile Organic Compound Data Sheet
  - B - Figure
  - C - Canister Sampling Field Data Sheet\*

\* This section affected by Revision 0.1.



# STANDARD OPERATING PROCEDURES

SOP: 1701  
PAGE: 2 of 14  
REV: 0.1  
DATE: 07/27/95

## SUMMA CANISTER SAMPLING

---

SUPERCEDES: SOP #1704; Revision 0.0; 09/12/94



# STANDARD OPERATING PROCEDURES

SOP: 1701  
PAGE: 3 of 14  
REV: 0.1  
DATE: 07/27/95

## SUMMA CANISTER SAMPLING

### 1.0 SCOPE AND APPLICATION

The purpose of this standard operating procedure (SOP) is to describe a procedure for sampling of volatile organic compounds (VOCs) in ambient air. The method is based on samples collected as whole air samples in Summa passivated stainless steel canisters. The VOCs are subsequently separated by gas chromatography (GC) and measured by mass-selective detector or multidetector techniques. This method presents procedures for sampling into canisters at final pressures both above and below atmospheric pressure (respectively referred to as pressurized and subatmospheric pressure sampling).

This method is applicable to specific VOCs that have been tested and determined to be stable when stored in pressurized and subatmospheric pressure canisters. The organic compounds that have been successfully collected in pressurized canisters by this method are listed in the Volatile Organic Compound Data Sheet (Appendix A). These compounds have been measured at the parts per billion by volume (ppbv) level.

These are standard (i.e., typically applicable) operating procedures which may be varied or changed as required, dependent on site conditions, equipment limitations or limitations imposed by the procedure or other procedure limitations. In all instances, the ultimate procedures employed should be documented and associated with the final report.

Mention of trade names or commercial products does not constitute U.S. EPA endorsement or recommendation for use.

### 2.0 METHOD SUMMARY

Both subatmospheric pressure and pressurized sampling modes use an initially evacuated canister. Both modes may also use a mass flow controller/vacuum pump arrangement to regulate flow. With the above configuration, a sample of ambient air is drawn through a sampling train comprised of components that regulate the rate and duration of sampling into a pre-evacuated Summa passivated canister. Alternatively, subatmospheric pressure sampling may be performed using a fixed orifice, capillary, or adjustable micrometering valve in lieu of the mass flow controller/vacuum pump arrangement for taking grab samples or short duration time-integrated samples. Usually, the alternative types of flow controllers are appropriate only in situations where screening samples are taken to assess for future sampling activities.

### 3.0 SAMPLE PRESERVATION, CONTAINERS, HANDLING, AND STORAGE

After the air sample is collected, the canister valve is closed, an identification tag is attached to the canister, and the canister is transported to a laboratory for analysis. Upon receipt at the laboratory, the canister tag data is recorded. Sample holding times and expiration should be determined prior to initiating field activities.

### 4.0 INTERFERENCES AND POTENTIAL PROBLEMS

Contamination may occur in the sampling system if canisters are not properly cleaned before use. Additionally, all other sampling equipment (e.g., pump and flow controllers) should be thoroughly cleaned. Instructions for cleaning the Summa canisters are described in ERT/SERAS SOP #1703, Summa Canister Cleaning Procedures.



# STANDARD OPERATING PROCEDURES

SOP: 1701  
PAGE: 4 of 14  
REV: 0.1  
DATE: 07/27/95

## SUMMA CANISTER SAMPLING

### 5.0 EQUIPMENT/APPARATUS

The following equipment/apparatus (Figure 1, Appendix B) is required:

#### 5.1 Subatmospheric Pressure Sampling Equipment

1. VOC canister sampler - whole air sampler capable of filling an initially evacuated canister by action of the flow controlled pump from vacuum to near atmospheric pressure. (Andersen Samplers Inc., Model 87-100 or equivalent).
2. Sampling inlet line - stainless steel tubing to connect the sampler to the sample inlet.
3. Sample canister - leak-free stainless steel pressure vessels of desired volume with valve and Summa passivated interior surfaces (Scientific Instrumentation Specialist, Inc., ID 83843, Andersen Samplers, Inc., or equivalent).
4. Particulate matter filter - 2- $\mu$ m sintered stainless steel in-line filter (Nupro Co., Model SS-2F-K4-2, or equivalent).
5. Chromatographic grade stainless steel tubing and fittings - for interconnections (Alltech Associates, Cat. # 8125, or equivalent). All materials in contact with sample, analyte, and support gases should be chromatographic grade stainless steel.
6. Fixed orifice, capillary, or adjustable micrometering valve - used in lieu of the electronic flow controller/vacuum pump for grab samples or short duration time-integrated samples.

#### 5.2 Pressurized Sampling Equipment

1. VOC canister sampler - whole air sampler capable of filling an initially evacuated canister by action of the flow controlled pump from vacuum to near atmospheric pressure. (Andersen Samplers Inc., Model 87-100).
2. Sampling inlet line - stainless steel tubing to connect the sampler to the sample inlet.
3. Sample canister - leak-free stainless steel pressure vessels of desired volume with valve and Summa passivated interior surfaces (Scientific Instrumentation Specialist, Inc., ID 83843, Andersen Samplers, Inc., or equivalent).
4. Particulate matter filter - 2- $\mu$ m sintered stainless steel in-line filter (Nupro Co., Model SS-2F-K4-2, or equivalent).
5. Chromatographic grade stainless steel tubing and fittings - for interconnections (Alltech Associates, Cat. #8125, or equivalent). All materials in contact with sample, analyte, and support gases should be chromatographic grade stainless steel.

### 6.0 REAGENTS



# STANDARD OPERATING PROCEDURES

SOP: 1701  
PAGE: 5 of 14  
REV: 0.1  
DATE: 07/27/95

## SUMMA CANISTER SAMPLING

This section is not applicable to this SOP.

### 7.0 PROCEDURE

#### 7.1 Subatmospheric Pressure Sampling

##### 7.1.1 Sampling Using a Fixed Orifice, Capillary, or Adjustable Micrometering Valve

1. Prior to sample collection, the appropriate information is completed on the Canister Sampling Field Data Sheet (Appendix C).
2. A canister, which is evacuated to 0.05 mm Hg and fitted with a flow restricting device, is opened to the atmosphere containing the VOCs to be sampled.
3. The pressure differential causes the sample to flow into the canister.
4. This technique may be used to collect grab samples (duration of 10 to 30 seconds) or time-integrated samples (duration of 12 to 24 hours). The sampling duration depends on the degree to which the flow is restricted.
5. A critical orifice flow restrictor will have a decrease in the flow rate as the pressure approaches atmospheric.
6. Upon sample completion at the location, the appropriate information is recorded on the Canister Sampling Field Data Sheet.

##### 7.1.2 Sampling Using a Mass Flow Controller/Vacuum Pump Arrangement (Andersen Sampler Model 87-100)

1. Prior to sample collection the appropriate information is completed on the Canister Sampling Field Data Sheet (Appendix C).
2. A canister, which is evacuated to 0.05 mm Hg and connected in line with the sampler, is opened to the atmosphere containing the VOCs to be sampled.
3. A whole air sample is drawn into the system through a stainless steel inlet tube by a direct drive blower motor assembly.
4. A small portion of this whole air sample is pulled from the inlet tube by a specially modified inert vacuum pump in conjunction with a mass flow controller.
5. The initially evacuated canister is filled by action of the flow controlled pump to near atmospheric pressure.
6. A digital time-program is used to pre-select sample duration and start and stop



# STANDARD OPERATING PROCEDURES

SOP: 1701  
PAGE: 6 of 14  
REV: 0.1  
DATE: 07/27/95

## SUMMA CANISTER SAMPLING

times.

7. Upon sample completion at the location, the appropriate information is recorded on the Canister Sampling Field Data Sheet.

### 7.2 Pressurized Sampling

#### 7.2.1 Sampling Using a Mass Flow Controller/Vacuum Pump Arrangement (Andersen Sampler Model 87-100)

1. Prior to sample commencement at the location, the appropriate information is completed on the Canister Sampling Field Data Sheet.
2. A canister, which is evacuated to 0.05 mm Hg and connected in line with the sampler, is opened to the atmosphere containing the VOCs to be sampled.
3. A whole air sample is drawn into the system through a stainless steel inlet tube by a direct drive blower motor assembly.
4. A small portion of this whole air sample is pulled from the inlet tube by a specially modified inert vacuum pump in conjunction with a mass flow controller.
5. The initially evacuated canister is filled by action of the flow controlled pump to a positive pressure not to exceed 25 psig.
6. A digital time-programmer is used to pre-select sample duration and start and stop times.
7. Upon sample completion at the location, the appropriate information is recorded on the Canister Sampling Field Data Sheet.

### 8.0 CALCULATIONS

1. A flow control device is chosen to maintain a constant flow into the canister over the desired sample period. This flow rate is determined so the canister is filled to about 88.1 kPa for subatmospheric pressure sampling or to about one atmosphere above ambient pressure for pressurized sampling over the desired sample period. The flow rate can be calculated by:

$$F = \frac{(P)(V)}{(T)(60)}$$

where:

- F = flow rate (cm<sup>3</sup>/min)  
P = final canister pressure, atmospheres absolute  
V = volume of the canister (cm<sup>3</sup>)



# STANDARD OPERATING PROCEDURES

SOP: 1701  
PAGE: 7 of 14  
REV: 0.1  
DATE: 07/27/95

## SUMMA CANISTER SAMPLING

T = sample period (hours)

For example, if a 6-L canister is to be filled to 202 kPa (two atmospheres) absolute pressure in 24 hours, the flow rate can be calculated by:

$$F = \frac{(2)(6000)}{(24)(60)} = .3\text{cm}^3/\text{min}.$$

2. If the canister pressure is increased, a dilution factor (DF) is calculated and recorded on the sampling data sheet.

$$DF = \frac{Y_a}{X_a}$$

where:

X<sub>a</sub> = canister pressure (kPa, psia) absolute before dilution.

Y<sub>a</sub> = canister pressure (kPa, psia) absolute after dilution.

After sample analysis, detected VOC concentrations are multiplied by the dilution factor to determine concentration in the sampled air.

### 9.0 QUALITY ASSURANCE/QUALITY CONTROL

The following general quality assurance procedures apply:

1. All data must be documented on standard chain of custody records, field data sheets, or site logbooks.
2. All instrumentation must be operated in accordance with operating instructions as supplied by the manufacturer, unless otherwise specified in the work plan. Equipment checkout and calibration activities must occur prior to sampling/operation, and they must be documented.

### 10.0 DATA VALIDATION

This section is not applicable to this SOP.

### 11.0 HEALTH AND SAFETY

When working with potentially hazardous materials, follow U.S. EPA, OSHA, and corporate health and safety practices. Specifically, pressurizing of Summa canisters should be performed in a well ventilated room, or preferably under a fume hood. Care must be taken not to exceed 40 psi in the canisters. Canisters are under pressure, albeit only 20-30 psi, and should not be dented or punctured. They should be stored in a cool dry place and always be placed in their plastic shipping boxes during transport and storage.

### 12.0 REFERENCES



# STANDARD OPERATING PROCEDURES

SOP: 1701  
PAGE: 8 of 14  
REV: 0.1  
DATE: 07/27/95

## SUMMA CANISTER SAMPLING

1. Ralph M. Riggin, Technical Assistance Document for Sampling and Analysis of Toxic Organic Compounds in Ambient Air, EPA-600/4-83-027 U. S. Environmental Protection Agency, Research Triangle Park, NC, 1983.
2. W. A. McClenny, J. D. Pleil, T. A. Lumpkin and K. D. Oliver, "Update on Canister-Based Samplers for VOCs," Proceedings of the 1987 EPA/APCA Symposium on Measurement of Toxic and Related Air Pollutants, May, 1987 APCA Publication VIP-8, EPA 600/9-87-010.
3. J. F. Walling, "The Utility of Distributed Air Volume Sets When Sampling Ambient Air Using Solid Adsorbents," Atmospheric Environ., 18:855-859, 1984.
4. J. F. Walling, J. E. Bumgarner, J. D. Driscoll, C. M. Morris, A. E. Riley, and L. H. Wright, "Apparent Reaction Products Desorbed From Tenax Used to Sample Ambient Air," Atmospheric Environ., 20:51-57, 1986.
5. Portable Instruments User's Manual for Monitoring VOC Sources, EPA-340/1-88-015, U.S. Environmental Protection Agency, Office of Air Quality Planning and Standards, Washington, D.C., June 1986.
6. R. A. Rasmussen and J. E. Lovelock, Atmospheric Measurements Using Canister Technology, J. Geophys. Res., 83: 8369-8378, 1983.
7. R. A. Rasmussen and M. A. K. Khalil, "Atmospheric Halocarbon: Measurements and Analysis of Selected Trace Gases," Proc. NATO ASI on Atmospheric Ozone, BO: 209-231.
8. EPA Method TO-14 "Determination of Volatile Organic Compounds (VOC's) in Ambient Air Using Summa Passivated Canister Sampling and Gas Chromatographic Analysis", May 1988.





# STANDARD OPERATING PROCEDURES

SOP: 1701  
PAGE: 9 of 14  
REV: 0.1  
DATE: 07/27/95

## SUMMA CANISTER SAMPLING

---

APPENDIX A  
Volatile Organic Compound Data Sheet  
SOP #1704  
July 1995



# STANDARD OPERATING PROCEDURES

SOP: 1701  
 PAGE: 10 of 14  
 REV: 0.1  
 DATE: 07/27/95

## SUMMA CANISTER SAMPLING

### Volatile Organic Compound Data Sheet

TABLE 1. VOLATILE ORGANIC COMPOUND DATA SHEET

COMPOUND (SYNONYM)	FORMULA	MOLECULAR WEIGHT	BOILING POINT (°C)	MELTING POINT (°C)	CAS NUMBER
Freon 12 (Dichlorodifluoromethane)	C12CF2	120.91	-29.8	-158.0	
Methyl chloride (Chloromethane)	CH3Cl	50.49	-24.2	-97.1	74-87-3
Freon 114 (1,2-Dichloro-1,1,2,2-tetrafluoroethane)	C1CF2CClF2	170.93	4.1	-94.0	
Vinyl chloride (Chloroethylene)	CH2=CHCl	62.50	-13.4	-1538.0	75-01-4
Methyl bromide (Bromomethane)	CH3Br	94.94	3.6	-93.6	74-83-9
Ethyl chloride (Chloroethane)	CH3CH2Cl	64.52	12.3	-136.4	75-00-3
Freon 11 (Trichlorofluoromethane)	CCl3F	137.38	23.7	-111.0	
Vinylidene chloride (1,1-Dichloroethene)	C2H2Cl2	96.95	31.7	-122.5	75-35-4
Dichloromethane (Methylene chloride)	CH2Cl2	84.94	39.8	-95.1	75-09-2
Freon 113 (1,1,2-Trichloro-1,2,2-trifluoroethane)	CF2ClCCl2F	187.38	47.7	-36.4	
1,1-Dichloroethane (Ethylidene chloride)	CH3CHCl2	98.96	57.3	-97.0	74-34-3
cis-1,2-Dichloroethylene	CHCl=CHCl	96.94	60.3	-80.5	
Chloroform (Trichloromethane)	CHCl3	119.38	61.7	-63.5	67-66-3
1,2-Dichloroethane (Ethylene dichloride)	C1CH2CH2Cl	98.96	83.5	-35.3	107-06-2
Methyl chloroform (1,1,1-Trichloroethane)	CH3CCl3	133.41	74.1	-30.4	71-55-6
Benzene (Cyclohexatriene)	C6H6	78.12	80.1	5.5	71-43-2
Carbon tetrachloride (tetrachloromethane)	CCl4	153.82	76.5	-23.0	56-23-5
1,2-Dichloropropane (Propylene dichloride)	CH3CHClCH2Cl	112.99	96.4	-100.4	78-87-5
Trichloroethylene (Trichloroethene)	C1CH=CCl2	131.29	87	-73.0	79-01-6
cis-1,3-Dichloropropene (cis-1,3-dichloropropylene)	CH3CCl=CHCl	110.97	76		
trans-1,3-Dichloropropene (cis-1,3-Dichloropropylene)	C1CH2CH=CHCl	110.97	112.0		
1,1,2-Trichloroethane (Vinyl trichloride)	CH2ClCHCl2	133.41	113.8	-36.5	79-00-5
Toluene (Methyl benzene)	C6H5CH3	92.15	110.6	-95.0	108-88-3
1,2-Dibromoethane (Ethylene dibromide)	BrCH2CH2Br	187.88	131.3	9.8	106-93-4
Tetrachloroethylene (Perchloroethylene)	C12C=CCl2	165.83	121.1	-19.0	127-18-4
Chlorobenzene (Phenyl chloride)	C6H5Cl	112.56	132.0	-45.6	108-90-7
Ethylbenzene	C6H5C2H5	106.17	136.2	-95.0	100-41-4
m-Xylene (1,3-Dimethylbenzene)	1,3-(CH3)2C6H4	106.17	139.1	-47.9	
p-Xylene (1,4-Dimethylxylene)	1,4-(CH3)2C6H4	106.17	138.3	13.3	
Styrene (Vinyl benzene)	C6H5CH=CH2	104.16	145.2	-30.6	100-42-5
1,1,2,2-Tetrachloroethane	CHCl2CHCl2	167.85	146.2	-36.0	79-34-5
o-Xylene (1,2-Dimethylbenzene)	1,2-(CH3)2C6H4	106.17	144.4	-25.2	
1,3,5-Trimethylbenzene (Mesitylene)	1,3,5-(CH3)3C6H3	120.20	164.7	-44.7	108-67-8
1,2,4-Trimethylbenzene (Pseudocumene)	1,2,4-(CH3)3C6H3	120.20	169.3	-43.8	95-63-6
m-Dichlorobenzene (1,3-Dichlorobenzene)	1,3-C12C6H4	147.01	173.0	-24.7	541-73-1
Benzyl chloride (α-Chlorotoluene)	C6H5CH2Cl	126.59	179.3	-39.0	100-44-7
o-Dichlorobenzene (1,2-Dichlorobenzene)	1,2-C12C6H4	147.01	180.5	-17.0	95-50-1
p-Dichlorobenzene (1,4-Dichlorobenzene)	1,4-C12C6H4	147.01	174.0	53.1	106-46-7
1,2,4-Trichlorobenzene	1,2,4-C13C6H3	181.45	213.5	17.0	120-82-1
Hexachlorobutadiene (1,1,2,3,4,4-Hexachloro-1,3-butadiene)					



# STANDARD OPERATING PROCEDURES

SOP: 1701  
PAGE: 11 of 14  
REV: 0.1  
DATE: 07/27/95

## SUMMA CANISTER SAMPLING

### APPENDIX B

Figure  
SOP #1704  
July 1995



# STANDARD OPERATING PROCEDURES

SOP: 1701  
PAGE: 12 of 14  
REV: 0.1  
DATE: 07/27/95

## SUMMA CANISTER SAMPLING

FIGURE 1. Subatmospheric/Pressurized Sampling Equipment

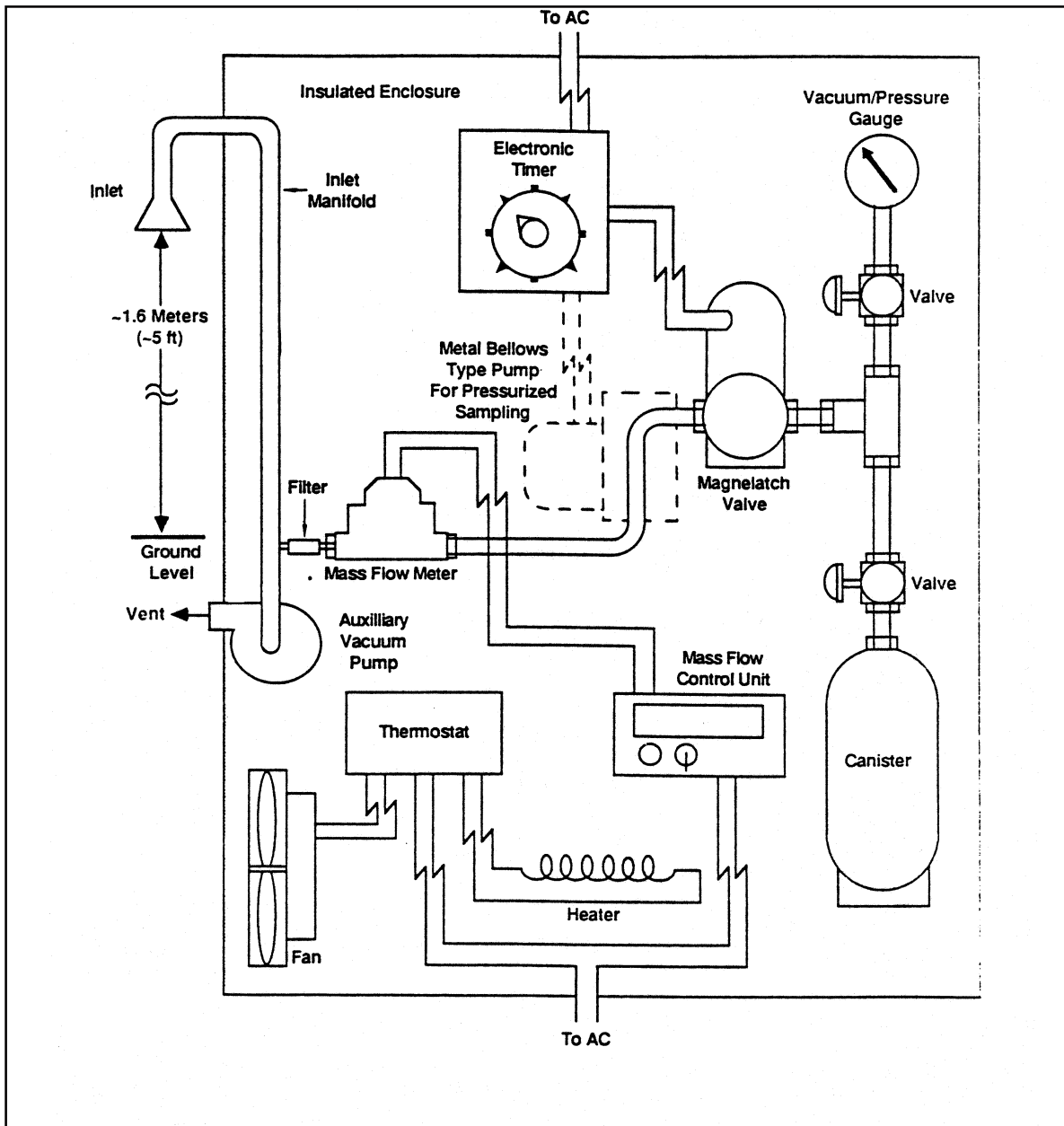



# STANDARD OPERATING PROCEDURES

SOP: 1701  
PAGE: 13 of 14  
REV: 0.1  
DATE: 07/27/95

## SUMMA CANISTER SAMPLING

---

### APPENDIX C

Canister Sampling Field Data Sheet  
SOP #1704  
July 199



# STANDARD OPERATING PROCEDURES

SOP: 1701  
PAGE: 14 of 14  
REV: 0.1  
DATE: 07/27/95

## SUMMA CANISTER SAMPLING



*EPA/Environmental Response Team*  
**Scientific, Engineering, Response and Analytical Services**  
Lockheed Martin Corp., Edison, NJ  
U.S. EPA Contract No. EP-W-09-031

Page \_\_\_ of \_\_\_



### Air Sampling Work Sheet

Site: \_\_\_\_\_

WA# \_\_\_\_\_

Sampler: \_\_\_\_\_

U.S. EPA/ERT WAM: \_\_\_\_\_

Date: \_\_\_\_\_

REAC Task Leader: \_\_\_\_\_

Sample #					
Location					
Summa #					
Orifice ID					
Analysis/Method					
Start Pressure					
End Pressure					
Time/Counter (Start)					
Time/Counter (Stop)					
Total Time					
Flow Rate (Start)					
Flow Rate (End)					
Flow Rate Average					
Sample Volume					

MET Station on Site?: Y/N