

1. Revisions must be initiated by an ECO. Exception-patent updates.
2. Artwork is property of and must be returned immediately after production to:
Stryker Instruments
Documentation Control Dept.
4100 E. Milham
Kalamazoo, MI (USA) 49001
3. Patent info last updated without an ECO on this date:
4. Translations provided by:
5. English equivalent:
6. Printing service (reference only):
Print Center

1 of 16

Color:

Black Graphics on White Background

Material:

20# Bond

Finish:

8 1/2 x 11 Booklet

stryker[®]

269-323-7700

800-253-3210

Orig.		Date	11/15/05	Approvals	S/ P. Welch	Date	11/15/05	Mktg.	S/ J. Lauria	Date	12/12/05	Title	Instructions For Use Cast Vac Lit		
Q.A.	S/ K. Cannan	Date	11/16/05	Eng.	S/ T. O'Keefe	Date	12/7/05	Reg. Affairs	S/ V. Franck	Date	12/9/05	Part No.	0986-001-011	Rev-	L

IMPORTANT INFORMATION: File in your maintenance records

CastVac™

Maintenance Manual & Operating Instructions

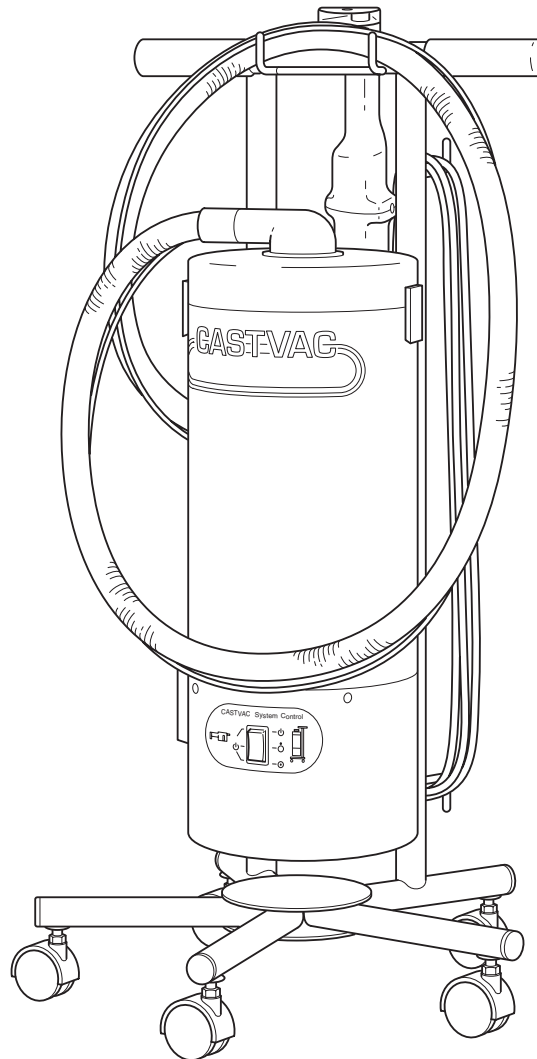

stryker®

Stryker Instruments
4100 E. Milham
Kalamazoo, Michigan
(USA) 49001
269-323-7700
1-800-253-3210
www.stryker.com

European Authorized Rep:
RA/QA Manager
Stryker France
ZAC Satolas Green Pusignan
Av. de Satolas Green
69881 MEYZIEU Cedex
France

REF 986
REF 987
REF 996

Important Information

WARNING - CAUTION - NOTE



This symbol is used to alert the reader to important safety and precautionary information. When displayed on the actual device, it refers the user to accompanying instructions.

Please read this manual and follow its instructions carefully. The words WARNING, CAUTION and NOTE carry special meanings and should be carefully reviewed.

WARNING: The personal safety of the patient/user may be involved. Disregarding this information could result in injury to the patient.

CAUTION: These instructions point out special service procedures or precautions that must be followed to avoid damaging the instrument.

NOTE: This provides special information to make maintenance easier or important instructions more clear.

User/Patient Safety



WARNINGS:

- Prior to each use, operate system components and inspect for damage. DO NOT use if damage is apparent. Take special precautions regarding electromagnetic compatibility (EMC) when using medical electrical equipment like the CastVac REF 996. Install and place the CastVac REF 996 into service according to the EMC information in this manual. Portable and mobile RF communications equipment can affect the function of the CastVac REF 996.
- Use only Stryker approved accessories. Other accessories may result in increased emissions or decreased immunity of the system. Contact your Stryker sales representative for a complete list of accessories. DO NOT modify any accessory. Failure to comply may result in patient and/or operating room staff injury.
- This equipment is not suitable for use in the presence of flammable anesthetic mixture with air or with oxygen or nitrous oxide.
- The CastVac is designed to vacuum dry material only. Do not use the CastVac to vacuum wet material. Used as a wet vacuum, the CastVac could present an electrical shock hazard.

Introduction

Read and understand these instructions before use. Familiarization with the Stryker CastVac prior to use is important. For further information contact your Stryker Instruments Representative or call Stryker Customer Service at (800) 253-3210. (Outside the USA, contact your nearest Stryker Subsidiary.)

The Stryker CastVac simultaneously suctions dust and chips as you cut casting material. The CastVac is designed to be used in combination with the Stryker Cast Cutter.

Models:

REF 986 CastVac with 8 foot hose and Mobile Stand, (100-120V unit)

REF 987 CastVac with 8 foot hose and Wall Mount, (100-120V unit)

REF 996 CastVac with 8 foot hose and Mobile Stand, (220-240V unit)

Symbol Definition

 A lightning bolt within a triangle is intended to alert service personnel of the presence of dangerous voltage that may cause injury or fatal electrical shock. Disconnect unit from electrical supply before servicing.

 An exclamation point within a triangle is intended to alert the user to the presence of important operating and maintenance (service instructions) in the literature accompanying the products.

 PROTECTIVE EARTH GROUND

 **STANDBY** - In this mode, the CastVac will run when the Cast Cutter power switch is turned on.

 **ON** (only for part of equipment)

 **OFF** (only for part of equipment)



CAST CUTTER

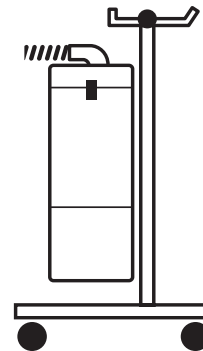

CASTVAC™

Hose Attachment

Hose/Cast Cutter Attachment

The vacuum hose must be securely connected to both the canister and the Cast Cutter to provide optimum power.

1. Depress the button located on the hose cuff and align it with the hole in the canister connector. Push hose into canister connector. Release button.

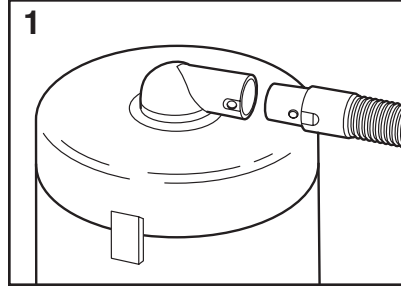

2. Remove the cover plug from the Cast Cutter.

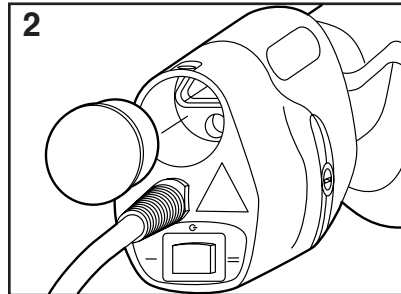

3. Depress the button located on the hose cuff and align with hole in Cast Cutter. Gently push the vacuum hose into the hose mount. Release button.

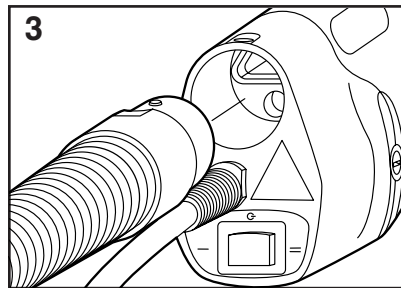

4. Attach the Cast Cutter power cord to the vacuum hose straps as shown.

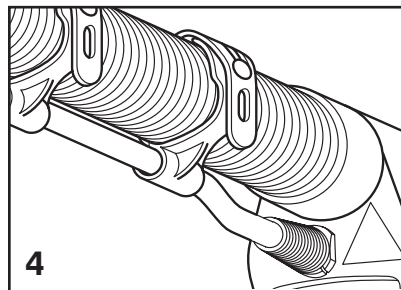

Operation

1. Plug the CastVac power cord into a hospital grade wall outlet. Plug the other end into the appliance inlet.

NOTES:

- CastVac REF 996 only, plug the source cord into a standard wall outlet.
- The function switch, located on the front of the canister, activates the equipment. It is not the power supply switch. To disconnect the vacuum from the power supply, unplug it at the wall receptacle.
- CastVac REF 996 can be unplugged at the vacuum's appliance inlet located at lower back portion of the canister.

2. Plug the Stryker Cast Cutter into the receptacle located on the side of the canister. See illustration. Wrap excess cord length around the handles of the CastVac Stand.

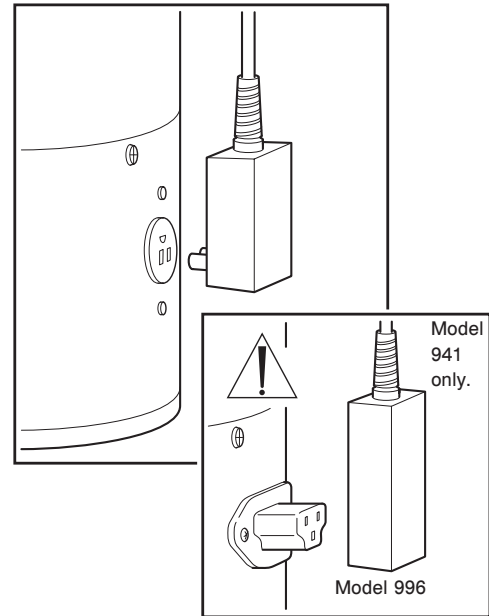

CAUTION: This receptacle is designed to accept Stryker Cast Cutter only. DO NOT attach other devices.

3. Operate the system in the desired mode by setting the 3-way switch located on the lower front portion of the canister. (See special instructions below).

Models REF 986, 987 & 996	The 3-way switch can be set for the following modes of operation:
<p>CASTVAC™ System Control</p>	<p>With the switch in the "STANDBY" position, both the Cast Cutter and CastVac are activated by the Cast Cutter switch.</p> <p>The vacuum runs only when the Cast Cutter is switched on and shuts down when the Cast Cutter is switched off.</p> <p>NOTE: CastVac model REF 996 will continue to run 10 seconds after the Cast Cutter is switched "OFF".</p>
<p>CASTVAC™ System Control</p>	<p>With the switch in the "OFF" position, only the Cast Cutter will run when activated.</p> <p>The CastVac remains off while the Cast Cutter is running.</p>
<p>CASTVAC™ System Control</p>	<p>The switch in the "ON" position enables the CastVac™ to run constantly.</p> <p>The Cast Cutter operates independently and can be turned on and off while the vacuum runs steadily.</p>

Filter Replacement



WARNING: To reduce the risk of electric shock or injury, unplug the CastVac prior to any maintenance activity.

1. Release the two latches located at the sides of the vacuum canister. Remove canister lid.
2. Position the High Performance Filter Cartridge in the approximate center of the canister. The filter opening must face up.
3. Place the lid over the canister so that the hose port in the lid and filter interface.
4. Press the lid down and twist hose port to seat in High Performance Filter Cartridge. Fasten latches.
5. Dispose of used filter in a suitable manner.

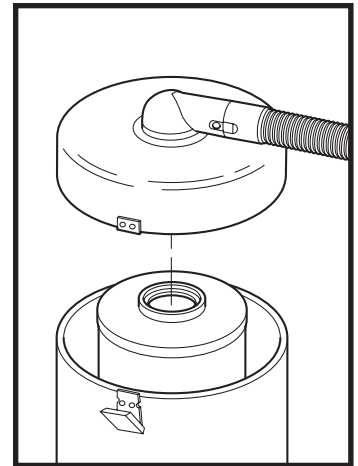

Cleaning & Maintenance

CAUTIONS:

- Allow vacuum to dry completely before using.
- DO NOT IMMERSE any portion of the vacuum unit.

1. Unplug vacuum unit before cleaning.
2. Use a sponge dampened in soapy water or disinfectant to clean all external areas of the canister and stand. DO NOT allow liquids to splash or seep inside the unit.

Periodic Maintenance

No adjustments are necessary. However, it is suggested that prior to use, the vacuum unit should be operated and inspected for any damage. DO NOT use if damage is apparent.

Activity/Item	Interval	Tools and Equipment Required	Instructions Models REF 986 & 987	Instructions Model REF 996
Source cord	Annually	N/A	Check for cracks. Return to Stryker for for repair if required.	Check for cracks. Replace cord.

Troubleshooting



WARNING: Disconnect from electrical supply before servicing.



<u>Problem</u>	<u>Action</u>
Vacuum fails to start	Ensure unit is plugged in and the three-way switch is in the correct position.
Low Suction	Replace filter cartridge. Check hose for blockage. Clean filter cartridge.
Unit starts but stops without being turned off.	The CastVac is provided with a thermal protective auto-reset switch. Make sure filter cartridge is clean. Ensure adequate ventilation is provided for exhaust.

Refer all other problems to your Stryker Instruments representative or call Stryker Instruments Customer Service at 1-800-253-3210. Outside the US, contact your nearest Stryker subsidiary.

To ensure the longevity, performance, and safety of this equipment, package in original package materials when storing or transporting.

Specifications

CastVac models REF 986 and 987

Electrical: 100-120V~ AC 60-50Hz 8.5A

Weight: 13.5 lbs. (6.1 kg)
 Height: 24.4 in. (620 mm)
 Diameter: 8.75 in (222 mm)

NEMA 5-15P "Hospital Grade" plug
 Cord Length: 12 ft. (3.6 m)

Outlet:
 NEMA 5-15R " Hospital Grade" 100-120V~
 Use with Stryker Cast Cutter models
 REF 840, 848, 940 only.

CLASS I

IPX0 Ordinary Equipment



Duty Cycle: Continuous Operation



CSA International

- CAN/CSA-C22.2 No. 601.1 M-90
- IEC 60601-1
- UL 60601-1

CastVac model REF 996

Electrical: 220-240 V~ AC 50-60Hz 4.75A
 Weight: 13.5 lbs. (6.1 Kg)
 Height: 24.4 in. (620 mm)
 Diameter: 8.75 in (222 mm)

Cord Length: 2.5M

Outlet: 220-240V~



Maximum load 0.75A
 Use with Stryker Cast
 Cutter REF 941

CLASS I

IPX0 Ordinary Equipment



Duty Cycle: Continuous Operation



Meets applicable requirements of:
IEC 60601-1 Safety Requirements

If the equipment experiences sporadic electrical interference:

- Turn off all electrical equipment not in use.
- Relocate electrical equipment; increase spacial distance.
- Plug equipment into different outlets.

Environmental Conditions

Operation

Storage and Transportation:

Temperature:



Relative Humidity:



Atmospheric Pressure:

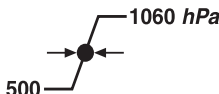
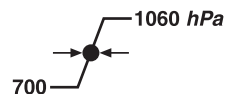

Guidance and manufacturer's declaration - electromagnetic emissions

The CastVac REF 996 is intended for use in the electromagnetic environment specified below. The customer or the user of the CastVac REF 996 should assure that it is used in such an environment.

Emissions test	Compliance	Electromagnetic environment - guidance
RF emissions CISPR 11	Group 1	The CastVac REF 996 uses RF energy only for its internal function. Therefore, its RF emissions are very low and are not likely to cause any interference in nearby electronic equipment.
RF emissions CISPR 11	Class A	The CastVac REF 996 is suitable for use in all establishments other than domestic and those directly connected to the public low-voltage power supply network that supplies buildings used for domestic purposes.
Harmonic emissions IEC 61000-3-2	Class A	
Voltage fluctuations/flicker emissions IEC 61000-3-3	Complies	

Guidance and manufacturer's declaration - electromagnetic immunity

The CastVac REF 996 is intended for use in the electromagnetic environment specified below. The customer or the user of the CastVac REF 996 should assure that it is used in such an environment.

Immunity test	IEC 60601 test level	Compliance level	Electromagnetic environment - guidance
<p>Conducted RF IEC 61000-4-6</p> <p>Radiated RF IEC 61000-4-3</p>	<p>3 Vrms 150 kHz to 80 MHz</p> <p>3 V/m 80 MHz to 2.5 GHz</p>	<p>3 Vrms</p> <p>3 V/m</p>	<p>Portable and mobile RF communications equipment should be used no closer to any part of the CastVac REF 996, including cables, than the recommended separation distance calculated from the equation applicable to the frequency of the transmitter.</p> <p align="center">Recommended separation distance</p> <p align="center">$d=1.67\sqrt{P}$</p> <p align="center">$d=1.67\sqrt{P}$ 80 MHz to 800 MHz</p> <p align="center">$d=2.33\sqrt{P}$ 800 MHz to 2.5 GHz</p> <p>Where P is the maximum output power rating of the transmitter in watts (W) according to the transmitter manufacturer and d is the recommended separation distance in meters (m)</p> <p>Interference may occur in the vicinity of equipment marked with the following symbol:</p> <p align="center"></p>

NOTE 1: At 80 MHz and 800MHz the higher frequency range applies.

NOTE 2: These guidelines may not apply in all situations. Electromagnetic propagation is affected by absorption and reflection from structures, objects and people.

Guidance and manufacturer's declaration - electromagnetic immunity

The CastVac REF 996 is intended for use in the electromagnetic environment specified below. The customer or the user of the CastVac REF 996 should assure that it is used in such an environment.

Immunity test	IEC 60601 test level	Compliance level	Electromagnetic environment - guidance
Electrostatic discharge (ESD) IEC 61000-4-2	±6 kV contact ±8 kV air	±2, 4,6 kV contact ±2,4, 8 kV air	Floors should be wood, concrete or ceramic tile. If floors are covered with synthetic material, the relative humidity should be at least 30%.
Electrical fast transient/burst IEC 61000-4-4	±2 kV for power supply lines ±1 kV for input/output lines	±2 kV for power supply lines ±1 kV for input/output lines	Mains power quality should be that of a typical commercial or hospital environment.
Surge IEC 61000-4-5	±1 kV differential mode ±2 kV common mode	±1 kV differential mode ±2 kV common mode	Mains power quality should be that of a typical commercial or hospital environment.
Voltage dips, short interruptions and voltage variations on power supply input lines IEC 61000-4-11	<5% U_T (>95% dip in U_T) for 0,5 cycle 40% U_T (60% dip in U_T) for 5 cycles 70% U_T (30% dip in U_T) for 25 cycles <5% U_T (>95% dip in U_T) for 5 sec	95% Reduction (10ms) 60% Reduction (100ms) 30% Reduction (500ms) 95% Reduction (5s)	Mains power quality should be that of a typical commercial or hospital environment. If the user of the CastVac REF 996 requires continued operation during power mains interruptions, it is recommended that the CastVac REF 996 be powered from an uninterruptible power supply or a battery.
Power frequency (50/60 Hz) magnetic field IEC 61000-4-8	3 A/m	3 A/m @ 50Hz CRT 1A/m	Power frequency magnetic fields should be at levels characteristics of a typical location in a typical commercial or hospital environment.

NOTE: U_T is the a.c. mains voltage prior to application of the test level.

Recommended separation distances between portable and mobile RF communications equipment and the CastVac REF 996

The CastVac REF 996 is intended for use in the electromagnetic environment in which radiated RF disturbances are controlled. The customer or the user of the CastVac REF 996 can help prevent electromagnetic interference by maintaining a minimum distance between portable and mobile RF communications equipment (transmitters) and the CastVac REF 996 as recommended below, according to the maximum output power of the communications equipment.

Rated maximum output power of transmitter W	Separation distance according to frequency of transmitter m		
	150 kHz to 80 MHz $d = [\frac{3.5}{V_1}] \sqrt{P}$	80 MHz to 800 MHz $d = [\frac{3.5}{E_1}] \sqrt{P}$	800 MHz to 2.5 GHz $d = [\frac{7}{E_1}] \sqrt{P}$
0.01	0.12	0.12	0.23
0.1	0.37	0.37	0.74
1	1.17	1.17	2.33
10	3.70	3.70	7.37
100	11.70	11.70	23.30

For transmitters rated at a maximum output power not listed above, the recommended separation distance d in meters (m) can be estimated using the equation applicable to the frequency of the transmitter, where P is the maximum output power rating of the transmitter in watts (W) according to the transmitter manufacturer.

NOTE 1: At 80 MHz and 800MHz, the separation distance for the higher frequency range applies.

NOTE 2: These guidelines may not apply in all situations. Electromagnetic propagation is affected by absorption and reflection from structures, objects and people.

Reorder Information

Models:

<u>Description</u>	<u>REF</u>
CastVac with 8 foot hose and Mobile Stand, (100-120V unit)	986
CastVac with 8 foot hose and Wall Mount, (100-120V unit).....	987
CastVac with 8 foot hose and Mobile Stand, (220-240V unit)	996

Accessories:

<u>Description</u>	<u>REF</u>
CastVac Mobile Stand only	989
High Performance Filter Cartridge	986-500
Vacuum Hose, 8 ft. long, with 6 Cord Clips	986-1-30

Retrofit items:

<u>Description</u>	<u>REF</u>
Vacuum Hose, 8 ft long: 986 CastVac to 840 Cast Cutter	986-840
Adaptor Cord (10 ft long and Vacuum Hose 8 ft long): 848 Cast Cutter to 986 CastVac.....	986-848
Adaptor Cord (10 in. long and Vacuum Hose 8 ft long): 940 Cast Cutter to 846 & 856 PlasterVac™.....	940-855
Adaptor Cord (10 in. long and Vacuum Hose 8 ft long): 940 Cast Cutter to 864 OrthoVac	940-864
Adaptor Cord (10 in. long and Vacuum Hose 8 ft long): 940 Cast Cutter to 886 PlasterVac	940-886

Limited Warranty

USA only, Stryker Instruments products are warranted to the original purchaser for a period of one year from the date of purchase to be free from defects in material and workmanship. This warranty extends to all purchasers and is limited to the repair or replacement of the product without charge when returned to Stryker Instruments, 4100 E. Milham, Kalamazoo, Michigan 49001-6197. Stryker can not accept responsibility for returns or replacements which have not been authorized.

This warranty does not cover damages caused by misuse or by failure to follow procedures outlined in this manual or as demonstrated by the Stryker Instruments representatives. This instrument is not warranted if it is used for purposes other than that of a cast vacuum.

This warranty gives you specific legal rights, and you may also have other rights which vary from state to state.

Outside the USA, contact your nearest Stryker subsidiary.

Euro Equiv. 0986-001-715
N. Euro Equiv. 0986-001-730
Japanese Equiv. 0986-001-725

stryker[®]

Stryker Instruments
4100 E. Milham
Kalamazoo, Michigan
(USA) 49001
269-323-7700
1-800-253-3210
www.stryker.com

European Authorized Rep:
RA/QA Manager
Stryker France
ZAC Satolas Green Pusignan
Av. de Satolas Green
69881 MEYZIEU Cedex
France