

# PRODUCT CATALOG

# 2020



## 10 great reasons to choose an SRI GC or data system:

1. SRI instruments are typically HALF the price of comparable units from other manufacturers.
2. SRI instruments come in a rugged, reusable shipping container.
3. Choose from 16 GC detectors, and mount four, five or even six on one GC. No one offers more detector choices!
4. Choose from 12 GC injector types and install up to five on one GC. Perform more analyses on one GC than you thought possible!
5. The built-in PeakSimple for Windows chromatography data system connects to your laptop or desktop computer using a USB cable. Software updates are FREE and can be downloaded from our website: [www.srigc.com](http://www.srigc.com)
6. SRI Instruments products come with a two year warranty and free technical support. When you call SRI, you reach a knowledgeable technician immediately, not voice mail.
7. Easy hardware upgrades-SRI can install an additional detector or injector on your existing GC in a matter of days.
8. Customization! SRI offers over 1,000 possible GC configurations-name your application.
9. Rent a GC or a data system if your need is short-term. SRI maintains an extensive selection of GC configurations so you can have what you need when you need it.
10. CE, TUV, GS and NRTL approvals: SRI manufactures all instruments in compliance with EN 61010 standards for laboratory equipment.



**Instrument s**

U.S. MANUFACTURER OF CUSTOM  
GAS CHROMATOGRAPH SYSTEMS

Contact us to order  
**SRI Instruments Europe GmbH** |  
+49 2224 76615  
[www.sri-instruments-europe.com](http://www.sri-instruments-europe.com)  
[mailto@sri-instruments-europe.com](mailto:sri@instruments-europe.com)



European Master distributor

[mailto@sri-instruments-europe.com](mailto:sri@instruments-europe.com)

[www.sri-instruments-europe.com](http://www.sri-instruments-europe.com)  
Drieschweg 13A  
53604 Bad Honnef / Deutschland

---

### Terms

---

Minimum Order	200€
Currency	Euro/ USD
Repairs	All repairs are performed at the SRI Europe GmbH.
Changes	Product specifications, design and prices may change without notice.

## Popular GC Configurations

Choose from our pre configured GC models for common applications.

3



## How to Build a Custom GC

The parts and processes that go into creating your custom SRI GC configuration.

25



## Chassis Options

Choose from six versatile GC chassis models: 8610C, 8610D, 8610V, 310, 410 & 110.

27



## GC Detectors

Select from 16 detector types and mount up to six per GC chassis.

36



## GC Injectors

Select up to five injectors and sample introduction options per GC chassis.

49



## GC Accessories

Methanizer, "whisper quiet" air compressor, columns and more!

72



## PeakSimple Chromatography Data Systems & Software

1 or 6 channel data systems with PeakSimple software.

75



## Warranty, Agency Approvals and Certifications

85



# Preconfigured GC Overview



We specialize in CUSTOM GAS CHROMATOGRAPHS. However, we have preconfigured a number of GCs for common applications. In some cases, the preconfigured GCs are less expensive than the identical hardware assembled “a la carte.” Each of the preconfigured GCs may be further customized (except the educational GCs).

## Page Configuration

- 4 Capillary FID GC For general hydrocarbon analysis
- 5 European Greenhouse GC For the greenhouse gases methane, carbon dioxide and nitrous oxide
- 7 Multiple Gas Analyzer #1 GC For fixed gases and light hydrocarbons
- 9 Multiple Gas Analyzer #5 GC For fixed gases and hydrocarbons to C20
- 11 Multiple Gas Analyzer + Sulfur GC For H<sub>2</sub>S, SO<sub>2</sub>, fixed gases and C1-C20 hydrocarbons
- 12 BTU Gas Analyzer GC For BTU content of natural gas
- 13 Method 25 Methane/Nonmethane GC For methane/nonmethane hydrocarbons as per EPA Method 25
- 14 Mud-Logging GC For total hydrocarbons plus detailed C1-C6 content
- 15 Environmental and BTEX GC For most EPA series 8000 methods
- 17 TO-14 Air Monitoring GC For EPA air monitoring methods
- 19 PCB GC For PCBs in soil and other solid matrices
- 20 Explosives GC For nitro-aromatic and nitramine explosives in the field
- 21 Rack Mount Mud-Logging GC For standard 19” racks
- 22 Gas-less™ Educational CCD GC For teaching GC without using compressed gases—right in the classroom
- 23 Educational TCD GC For demonstrating gas chromatography on the same equipment students will encounter in industry
- 24 Educational FID GC For teaching undergraduate gas chromatography or graduate research

# Capillary FID GC System



- FID Detector
  - 30 meter Capillary Column
  - Built-in, “whisper quiet” Air Compressor
  - 1 Channel PeakSimple Data System
  - On-Column Injector
- ...on the compact 8610C chassis

The Capillary FID GC System is a state of the art, general purpose, temperature programmable GC in a compact, low-cost package. It includes everything you need to separate and detect fuels and other hydrocarbon compounds. In addition to a wide range of general gas chromatography applications, the Capillary FID GC is excellent for both environmental and quality control applications.

The 30 meter capillary column can efficiently separate hydrocarbons up to  $C_{40}+$ . The On-column injector for 0.53mm capillary columns is good for liquid and gas samples with high and low boiling analytes—no boiling point discrimination. The built-in, “whisper quiet” air compressor provides a nearly silent supply of combustion air for the FID detector, so an air cylinder is not required for most applications. The optional Split/Splitless injector upgrade allows for the use of 0.32mm, 0.25mm and smaller capillary columns.

These six chromatograms resulted from analyzing various fuels with an SRI Capillary FID GC System. The chromatograms reveal the characteristic hydrocarbon range and fingerprint of each fuel. All six runs were performed under identical conditions.

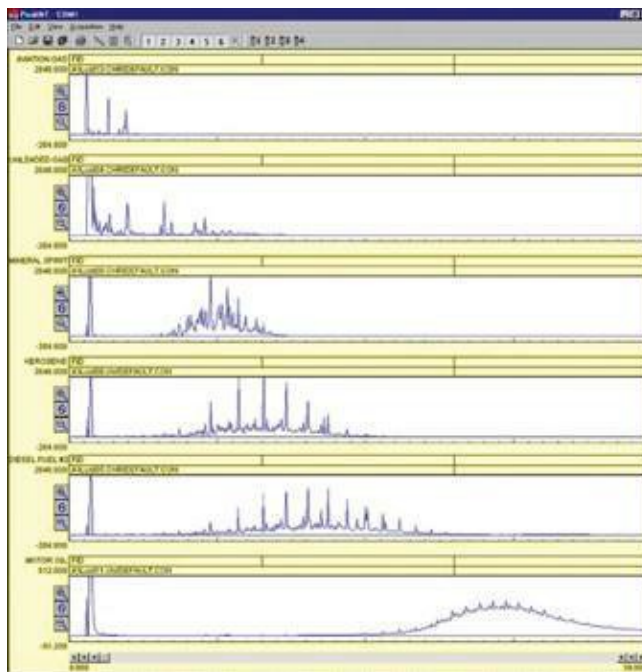

**8610-5400**

## Capillary FID GC System

OPTIONS & UPGRADES: split/splitless injector, PTV injector, additional detectors with 6 channel USB PeakSimple data system, Methanizer, gas sampling valves, additional column(s), autosampler.  
(VOLTAGE: for 115VAC, use 8610-5405-1; for 230VAC, use 8610-5405-2)

# European Greenhouse Gas GC



- ECD and FID-Methanizer Detectors
  - Pre and main column for each channel
  - Two 10-Port Gas Sampling Valve & Sample Loop
  - 6 channel PeakSimple Data System
  - On-Column Injector
- ...on the compact 8610C chassis

The Greenhouse GC is designed for the detection of carbon dioxide ( $\text{CO}_2$ ), methane ( $\text{CH}_4$ ) and nitrous oxide ( $\text{N}_2\text{O}$ ). Depending upon the volume of the sample loop on the gas sampling valve, it can detect trace levels or high concentrations. It may be used for stack or ambient air monitoring, or in a plane for atmospheric air analysis.

The Greenhouse GC is not limited to  $\text{CO}_2$ ,  $\text{CH}_4$  and  $\text{N}_2\text{O}$ . The FID-Methanizer detects hydrocarbons as well as  $\text{CO}$  and  $\text{CO}_2$  (as methane). The sensitive ECD detector responds to electronegative compounds, especially chlorinated, fluorinated or brominated molecules like PCBs and pesticides. With a low-volume sample loop, the Greenhouse GC can be used to measure gases produced by bacterial metabolic processes and life cycles.

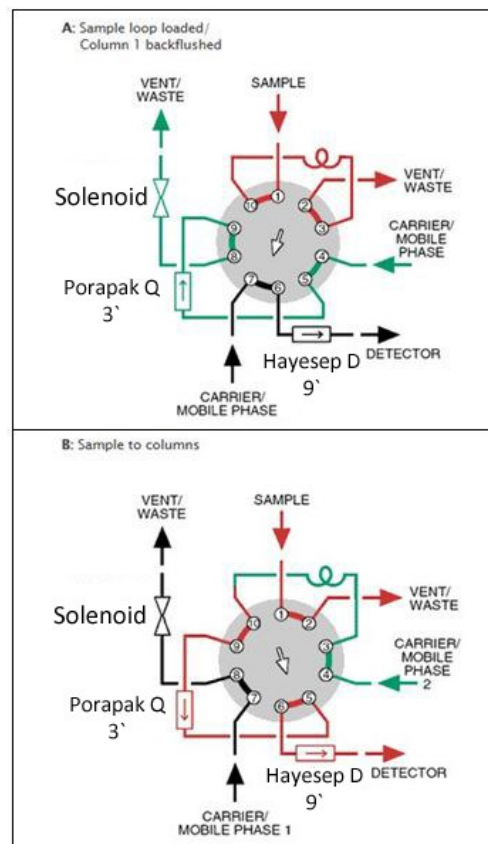

8610-0040-EU

European Greenhouse Gas GC

OPTIONS & UPGRADES: additional sample loops, additional detectors  
(VOLTAGE: for 115VAC, use 8610-0040-1; for 230VAC, use 8610-0040-2)

# European Greenhouse Gas GC

## Plumbing European Greenhouse Gas Chromatograph:

Both 10-Port-Valves are working in the same way - plumbing is the same.

There are two different positions of the 10-Port-Valve - "Load-Position" and "Inject-Position". First draw shows the "Load-Position". In this position the sample will be flushed on both sample loops with one injection by syringe or sampler. The run is started by pressing "Start Run" or a remote start signal from the autosampler. All relays are controlled by software.

After you start to run - both valves rotate to the "Inject-Position" - you can see in the second drawing that now the sample loops are switched into the carrier gas stream. The sample passes through the pre-column and main column. Water is retained by the pre-column longer than CH<sub>4</sub>, CO<sub>2</sub> and N<sub>2</sub>O. Before the water leaves the pre-column, - both 10-Ports-Valves are switched back to the "Load-Position" (Figure 1) and at same time Relay "A" will open a solenoid valve to backflush the water to vent. Now the flow direction in the pre-column is changed. In this time all the other compounds are on the main columns on the way to the detectors.

### 1 ml Ambient Air: CH<sub>4</sub> and CO<sub>2</sub> Detection FID-Methanizer

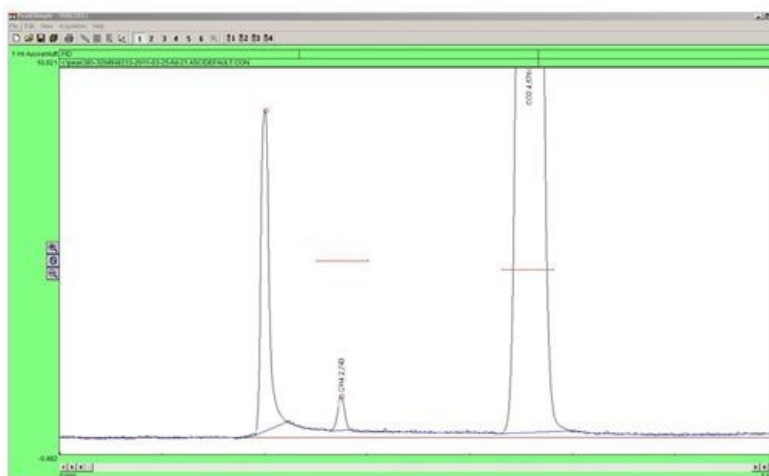

### 1ml Ambient Air: N<sub>2</sub>O Detection ECD

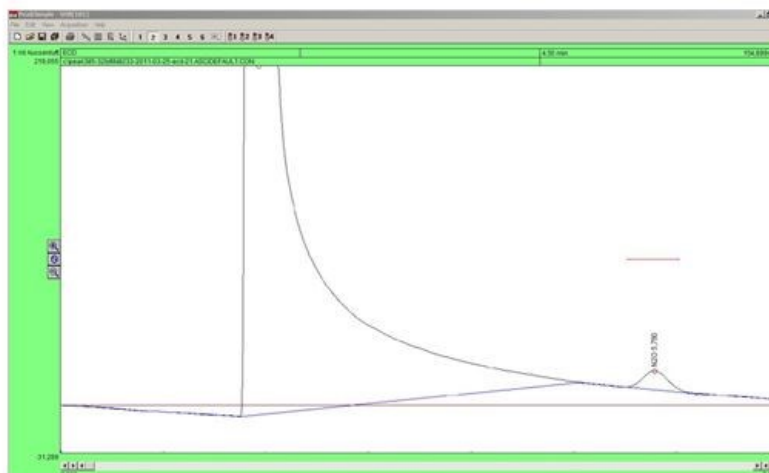

# Multiple Gas Analyzer #1 GC System

Separates multiple gases with a single injection

Very tolerant of user adjustments and timing variations

Simpler than other multiple gas capable systems

The basic model includes:

- TCD Detector
- Two Columns - MoleSieve 13X & Silica Gel
- 10-port Gas Sampling Valve and Loop
- 1 channel PeakSimple Data System

...on the compact 8610C chassis



The SRI Multiple Gas Analyzer #1 GC System (MG#1) can separate multiple gases with a single injection. It is pre plumbed and ready to resolve  $H_2$ ,  $O_2$ ,  $N_2$ , Methane, CO, Ethane,  $CO_2$ , Ethylene,  $NO_x$ , Acetylene, Propane, Butanes, Pentanes and  $C_6$ - $C_8$ . The MG#1 is very tolerant of user adjustments and timing variations because it is simpler than other multi-gas capable systems. Unlike complicated and timing-critical gas analysis configurations with three or four columns and three or four valves, the SRI Multiple Gas Analyzer uses a single 10-port gas sampling valve and two packed columns: a 2 meter Molecular Sieve 13X and a 2 meter Silica Gel.

The basic Multiple Gas Analyzer #1 is equipped with a TCD detector for detection limits in the 200-500ppm range. The second option is a TCD-Methanizer-FID configuration, which provides 5ppm detection limits for CO,  $CO_2$  and all hydrocarbons. The third option is a TCD-HID detector combination for detection limits in the 10ppm range for all analytes.

This chromatogram shows the separation of a 1% Gas Mix + 2% ethane sample on a basic TCD equipped MG#1.

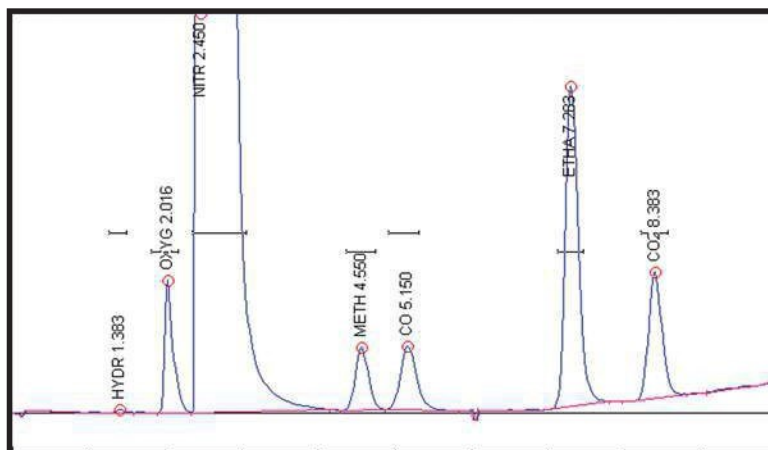



# Multiple Gas Analyzer #1 GC System

The basic model includes:

- TCD Detector
- FID-Methanizer
- Two Packed Columns
- 10-port Gas Sampling Valve and Loop
- 1 or 6 channel PeakSimple Data System

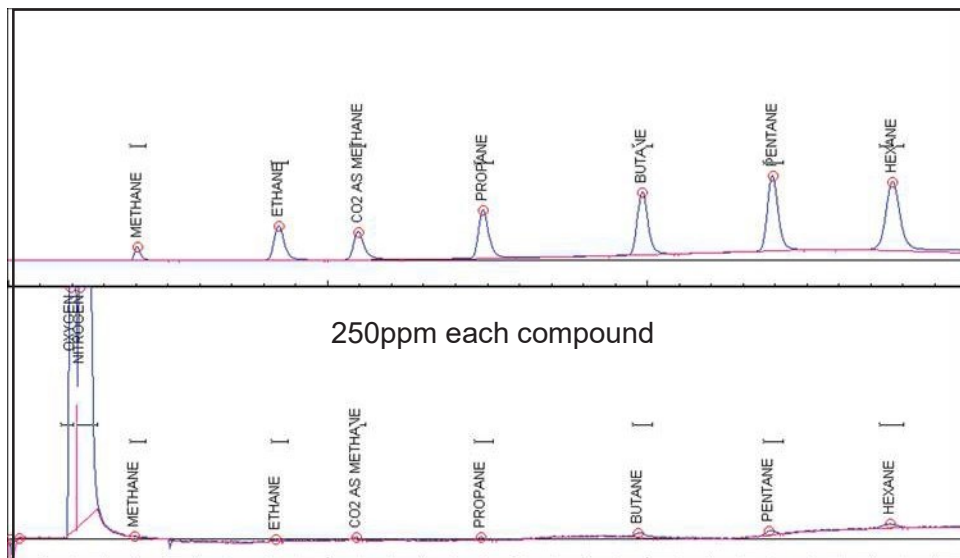
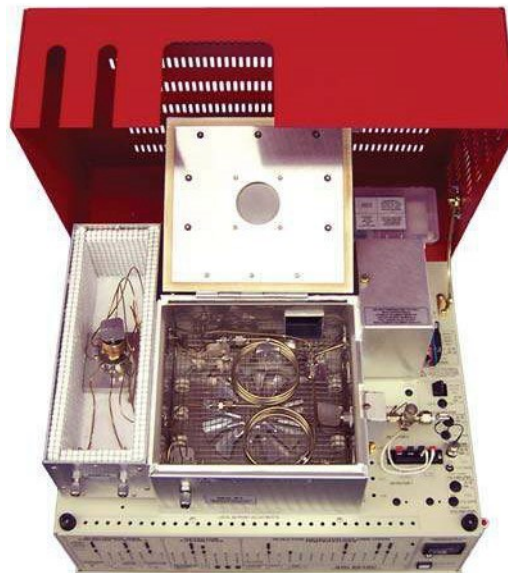

The FID measures the C<sub>1</sub>-C<sub>6</sub> hydrocarbons, plus CO and CO<sub>2</sub>, which are converted to methane by the Methanizer in the FID jet.

The TCD measures hydrogen, oxygen, nitrogen, methane and other compounds whose concentrations are at least 200-500ppm.

- |           |  |
|-----------|--|
| 8610-0070 | Multiple Gas Analyzer #1 with TCD detector and 1 channel PeakSimple data system  |
| 8610-0071 | Multiple Gas Analyzer #1 with TCD, Methanizer, FID, built-in "whisper quiet" air compressor and 6 channel PeakSimple data system |
| 8610-0072 | Multiple Gas Analyzer #1 with TCD and HID detectors, and 6 channel PeakSimple data system  |

OPTIONS & UPGRADES: 6 channel USB PeakSimple data system, additional gas sampling valve, additional detectors  
(VOLTAGE: for 115VAC, use "part number-1" [ex: 8610-0070-1] for 230VAC, use "part number-2")

# Multiple Gas Analyzer #5 GC System

- Separates multiple gases with a single injection
- Very tolerant of user adjustments and timing variations
- Simpler than other multiple gas capable systems

- The basic model includes:
- TCD Detector
  - Methanizer, FID, and HID options
  - Two 10-port Gas Sampling Valves and Loops
  - 3 Columns - MoleSieve 13X & HaySep-D .5 and 2 m
  - 1 or 6 channel PeakSimple Data System
- ...on the compact 8610C chassis



Unfortunately there is no single column that can separate: Hydrogen, Oxygen, Nitrogen, Methane, CO, CO2, Ethane, Water, Propane, Butane, and Pentane. Over the years, SRI Instruments has devised several solutions to this analytical problem, starting with the MultipleGas#1 configuration and evolving to the present MultipleGas#5 configuration.

The Thermal Conductivity Detector can detect all the gases listed above, besides hydrogen, from 200ppm to 100% concentration. The Flame Ionization Detector can detect hydrocarbons down to 1ppm, and with the Methanizer attachment, CO and CO2 down to 1ppm.

This model, is highly customizable, as are most of our GCs. It can be modified to have a third valve, more detectors, and more columns.

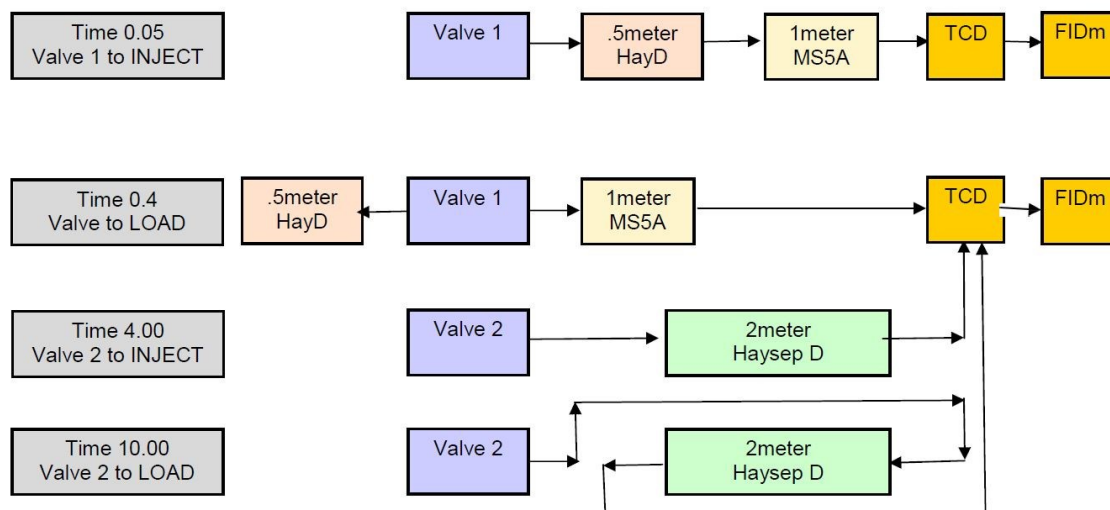

## Multiple Gas Analyzer #5 GC System

The schematic above shows the 4 steps in the MG5 analysis after the sample has been loaded into the loop of each valve.

**STEP 1:** Valve1 is turned to the INJECT position ( Relay G on ). The carrier gas pushes the sample out of the valve loop onto the 5. meter Haysep D column. H<sub>2</sub>, O<sub>2</sub>, N<sub>2</sub> CH<sub>4</sub> and CO migrate through the .5 meter HayD column very quickly and land on the 1 meter MS5A column.

**STEP 2:** Valve1 is turned back to the LOAD position ( Relay G off ). Carrier gas continues to push the H<sub>2</sub>, O<sub>2</sub>, N<sub>2</sub>, CH<sub>4</sub> and CO molecules through the MS5A column towards the detectors. Also carrier gas backflushes any remaining molecules backwards through the .5 meter HayD column out to vent ( not through the detectors ). The molecules which remain on the .5 meter column are CO<sub>2</sub>, Water, and C<sub>2</sub> and higher hydrocarbons. These molecules would get stuck on the MS5A column if they were allowed onto the MS5A column. However, they easily backflush out of the HayD.

**STEP 3:** Valve2 is turned to the INJECT position ( Relay F on ). The carrier gas pushes the molecules in the loop of Valve2 onto the 2 meter HayD column in the “forward” direction. H<sub>2</sub>, O<sub>2</sub>, N<sub>2</sub> and CO elute from the column very quickly as one peak, followed by the CH<sub>4</sub> peak, the CO<sub>2</sub>, water and the hydro- carbons from C<sub>2</sub>-C<sub>6</sub>.

**STEP 4:** At some point in the analysis Valve2 is returned to the LOAD position. This reverses ( back- flushes ) the flow direction in the HayD column. Any peaks which have not yet exited the HayD column now back out of the column and into the detector. If, for example the analysis had no peaks after CO<sub>2</sub> ( or you did not care about any peak after CO<sub>2</sub> ), then you would backflush after the CO<sub>2</sub> peak. Any peaks remaining in the HayD column would come out in a “lump”.

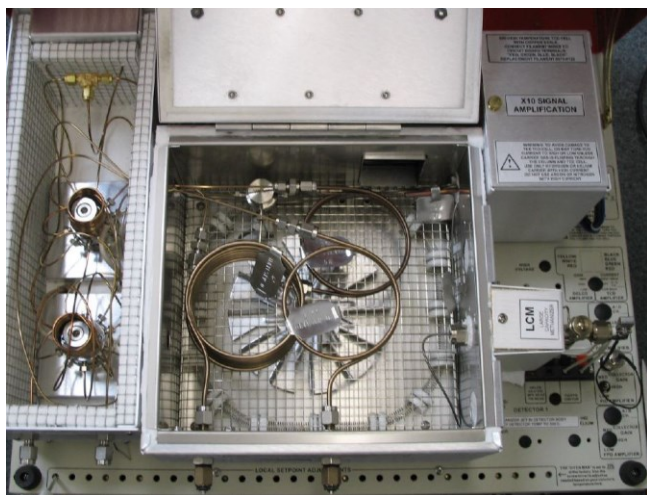

- |           |   |
|-----------|---|
| 8610-0570 | Multiple Gas Analyzer #2 GC with TCD detector and 1 channel PeakSimple data system  |
| 8610-0571 | Multiple Gas Analyzer #2 GC with TCD, Methanizer, FID, built-in “whisper quiet” air compressor and 6 channel PeakSimple data system |
| 8610-0572 | Multiple Gas Analyzer #2 GC with TCD and HID detectors, and 6 channel PeakSimple data system  |

## Multiple Gas Analyzer + Sulfur GC Systems



- FID Detector
  - 30 meter Capillary Column
  - Built-in, “whisper quiet” Air Compressor
  - 6 Channel PeakSimple Data System
  - On-Column Injector
- ...on the compact 8610C chassis

Many analysts require natural gas analysis for BTU value calculations or drilling and mudlogging applications. Frequently, sulfur compounds are also of interest.

Because low sulfur concentrations (<50ppm) are difficult to measure, SRI has enhanced our popular Multiple Gas Analyzer GCs to simultaneously monitor low levels of sulfur compounds. The additional hardware required is an FPD/FID detector, which selectively detects sulfur down to mid-ppb range, and a room temperature Silcosteel sample loop.



Room Temperature Silcosteel sample loop

One reason sulfur is so difficult to measure is that it disappears on contact with hot stainless steel surfaces; even limited contact with a hot stainless steel sample loop will destroy any sulfur in the gas sample. Our solution is to use a Silcosteel-lined transfer line leading to a splitter, and a 60 meter thick film capillary column. While Teflon columns are sometimes also used for sulfur analysis, the natural gas analysis (using MoleSieve and SilicaGel) requires column temperatures of 250°C or higher. Since the sulfur column is located in the same column oven, it is essential to use a column like the 60 meter capillary which can tolerate the higher temperatures.

**8610-0073 Multiple Gas Analyzer #1 + Sulfur GC with TCD, FID, and FPD/FID detectors, methanizer, built-in air compressor, 3 columns, and Silcosteel sample loop**

**8610-0373 Multiple Gas Analyzer #3 + Sulfur GC with TCD, FID-methanizer, and FPD/FID detectors, built-in air compressor, 3 columns, and Silcosteel sample loop**

OPTIONS & UPGRADES: split/splitless and PTV injectors, additional column(s), gas sampling valve, Thermal Desorber  
(VOLTAGE: for 115VAC, use “part number-1” [ex: 8610-0073-1] for 230VAC, use “part number-2”)

# BTU Gas Analyzer GC System



- TCD Detector
- 10-port Gas Sampling Valve
- 1 channel PeakSimple Data System
- 30 meter x 0.53mm MXT-1 Capillary Column
- 1 meter HayeSep-D Column
- ...on the compact 8610C chassis

This BTU GC is customized with an FID detector, an additional gas sampling valve, and a built-in 6 channel PeakSimple data system.

The BTU Gas Analyzer GC system is preplumbed and ready to measure N<sub>2</sub>, methane, CO<sub>2</sub>, ethane, H<sub>2</sub>O, propane, iso- and normal butanes, iso- and normal pentanes and C<sub>6</sub> plus backflush. The main benefits of the SRI BTU Gas Analyzer system are simplicity, low cost and the ability to determine the water content of the gas.

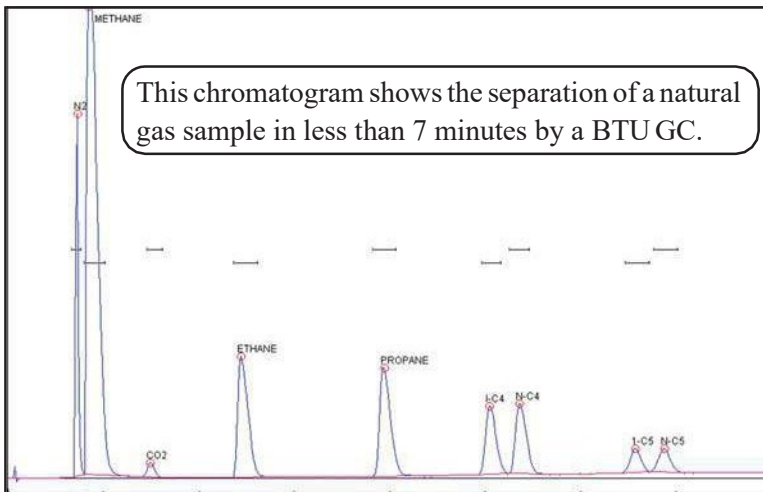

The SRI BTU Gas Analyzer uses just a single 10 port gas sampling valve and two columns, and is tolerant of valve timing variations or operator adjustments. Unlike the widely used competitive micro GCs, the SRI BTU Gas Analyzer GC system is not only tolerant of water in the sample gas, but it actually generates a quantifiable water peak. The seven minute analysis may be longer than a micro GC analysis, but the BTU GC does not need baking out between runs. Therefore, about the same number of runs may be made per day with the BTU GC as with a typical micro GC.

The BTU Gas Analyzer can be configured with a TCD detector only, for detection limits in the 200-500ppm range. Other detectors can be added, such as the HID, FID, or FPD for applications requiring higher sensitivity or selectivity.

**8610-3070**

## BTU Gas Analyzer GC System

OPTIONS & UPGRADES: additional detectors with a 6 channel USB PeakSimple data system, FID, Methanizer, split / splitless and PTV injectors, additional gas sampling valves, additional columns (VOLTAGE: for 115VAC, use 8610-3070-1; for 230VAC, use 8610-3070-2)

## Method 25 Methane/Nonmethane GC System

- FID Detector
  - HayeSep-D Column
  - 10-port “Backflush” Gas Sampling Valve
  - Built-in “whisper quiet” Air Compressor
  - 1 channel PeakSimple Data System
- ...on the compact 8610C chassis

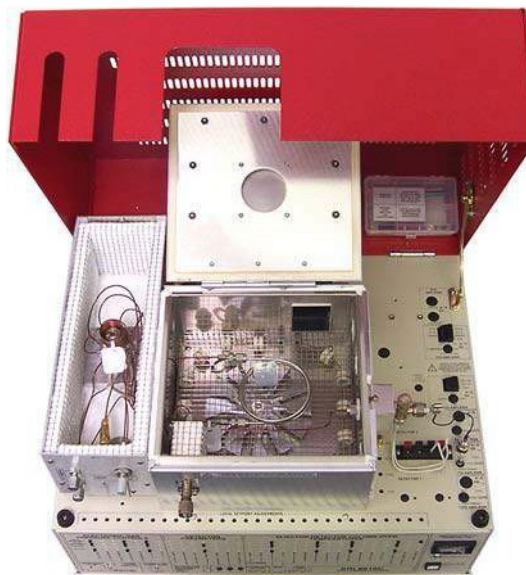

The SRI Method 25 GC system is equipped with an FID detector, built-in air compressor and 10-port gas sampling valve to quickly determine methane/nonmethane hydrocarbons as per EPA Method 25.

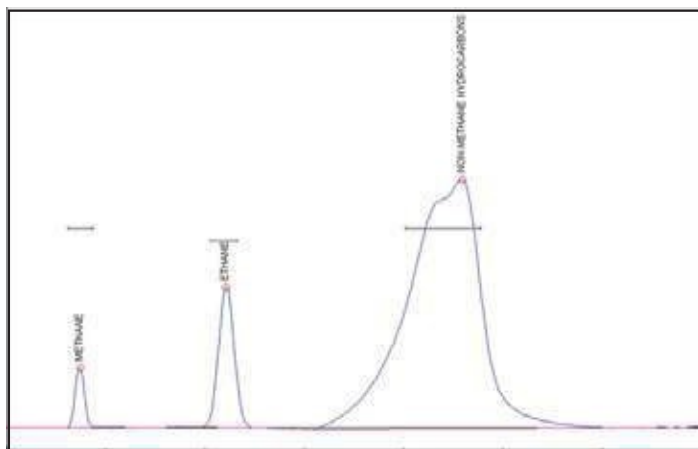

In this typical methane/nonmethane analysis, the nonmethane hydrocarbons were backflushed after the ethane peak. Depending upon the operator's needs, the valve timing could have been set to backflush after the methane or after the C<sub>3</sub>, C<sub>4</sub>, C<sub>5</sub> or C<sub>6</sub> hydrocarbons.

The sample is connected to the inlet port on the GC, where it fills the 1mL sample loop on the gas sampling valve. The valve is then automatically rotated to inject the sample onto the column, which separates the methane (and optionally the ethane) away from the rest of the hydrocarbons. After the elution of the compound(s) of interest, the gas sampling valve is automatically returned to the starting position, which backflushes the rest of the hydrocarbons into the detector.

The single channel PeakSimple data system controls the temperature programmable column oven and the gas sampling valve, collects the data, quantitates the nonmethane hydrocarbons and produces a printed report. The system comes standard with a HayeSep-D column, but may be equipped with other column types as desired.

**8610-0025**

### Method 25 GC System

OPTIONS & UPGRADES: additional detectors with 6 channel USB PeakSimple data system, Methanizer, split/splitless and PTV injectors, additional gas sampling valves & columns, autosampler.  
(VOLTAGE: for 115VAC, use 8610-0025-1; for 230VAC, use 8610-0025-2)

# Mud-Logging GC System



- Dual FID Detectors
  - HayeSep-D Column
  - 10-port Gas Sampling Valve
  - Built-in “whisper quiet” Air Compressor
  - 6 channel PeakSimple Data System
- ...on the compact 8610C chassis

The Mud-logging GC system is designed to provide a continuous reading of total hydrocarbons in a gas stream while periodically performing a chromatographic separation of the sample to determine the exact composition of the sample gas stream.

The sample gas stream (at a regulated pressure) is connected to a bulkhead fitting on the GC’s heated valve oven where it flows through the loop of the 10 port gas sampling valve, and also to the second FID detector, which continually monitors the total hydrocarbon content of the gas. Automatically, at a repeating time interval controlled by the operator, the gas sampling valve injects the contents of its loop into the GC column, where it is separated into the constituent hydrocarbon peaks and detected by the first FID detector.

The built-in, six channel PeakSimple data system displays both the continuous total hydrocarbon reading and the separated peaks. An alarm function alerts the operator for any out-of-range readings. Summary reports are easily printed or copied to Excel or similar programs.

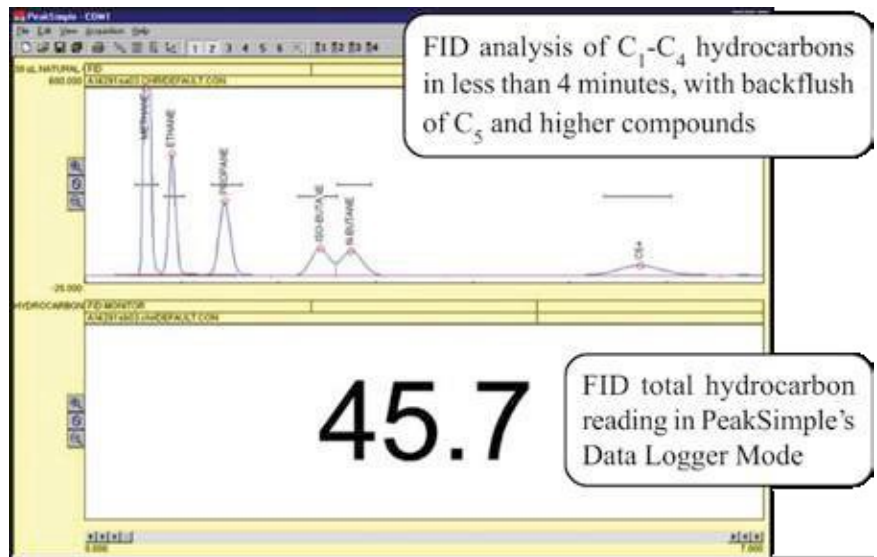

**8610-0065**

## Mud-Logging GC System

OPTIONS & UPGRADES: One-Minute Analysis, PTV and split/splitless injectors, additional gas sampling valves  
(VOLTAGE: for 115VAC, use 8610-0065-1; for 230VAC, use 8610-0065-2)

# Environmental & BTEX GC Systems

- PID Detector
- FID/DELCD Combination Detector
- Built-in Method 5030 or 5030/5035 compliant Purge & Trap
- Built-in “whisper quiet” Air Compressor
- 6 channel PeakSimple Data System
- 60 meter Capillary Column
- ...on the compact 8610C chassis

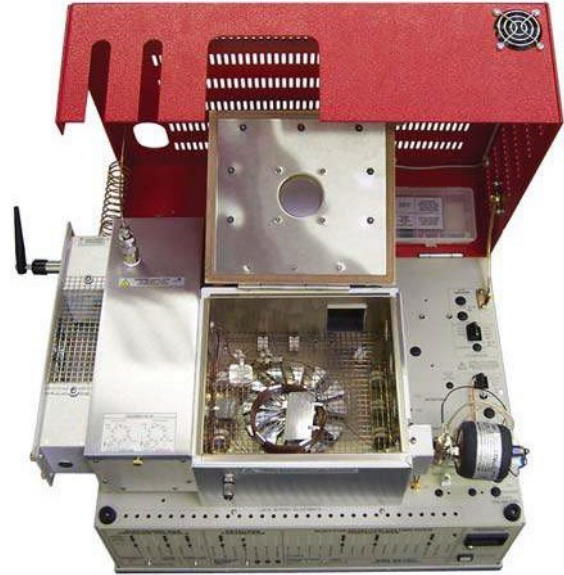

## Optional Equipment:

- Thermal Desorber for semivolatiles
- An additional gas sampling valve
- A vacuum pump interface for air sampling
- Additional detectors

For laboratory or mobile field testing where space and versatility are critical, choose the Environmental GC system. Equipped with Method 5030 or 5030/5035 compliant Purge & Trap, PID and FID/DELCD detectors, it will easily generate certification quality data for EPA Methods 8021, 8010, 8015, TO-14 and many others. With the optional thermal desorber, you can quickly screen for pesticides, PCBs, diesel and other semivolatiles. The standard on-column injection port allows for syringe injection and a second injector may be installed if desired. For users who do not need the chlorine/bromine selective DELCD detector, the same GC configuration minus the DELCD is available as the BTEX GC.

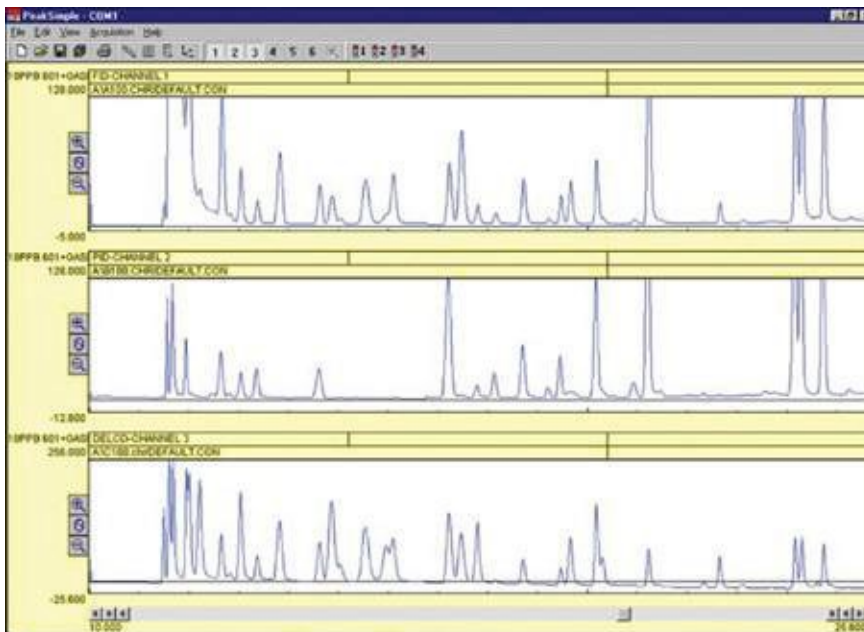

These three chromatograms are from an analysis of Method 8021 standard plus gases on an SRI Environmental GC system. Peak identities can be confirmed by comparing the results from the three different detectors. Peaks which often coelute, such as benzene and carbon tetrachloride, can still be measured since the PID responds only to the benzene, while the DELCD only responds to the carbon tetrachloride.



# Environmental & BTEX GC Systems

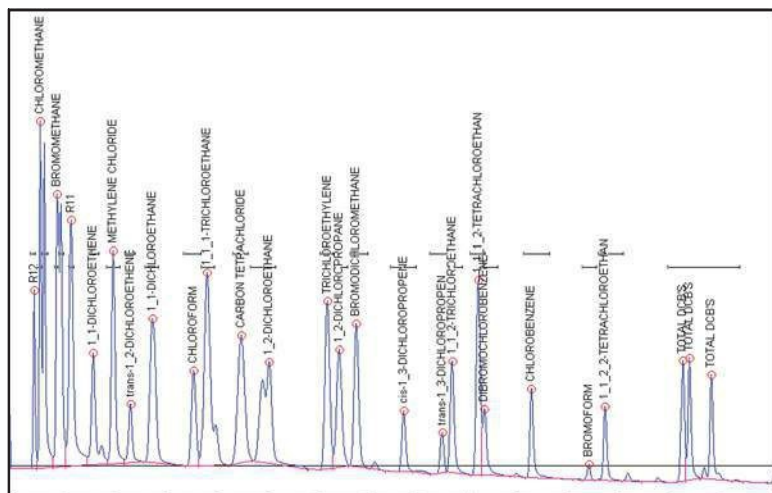

The DELCD chromatogram is shown at left in more detail and with the peaks labeled for identification. The DELCD is completely selective for compounds containing chlorine and/or bromine. Other analytes do not respond at all, even at very high levels. The DELCD actually operates on the FID's exhaust gases; therefore, all contaminants are precombusted by the FID to CO<sub>2</sub> and H<sub>2</sub>O.

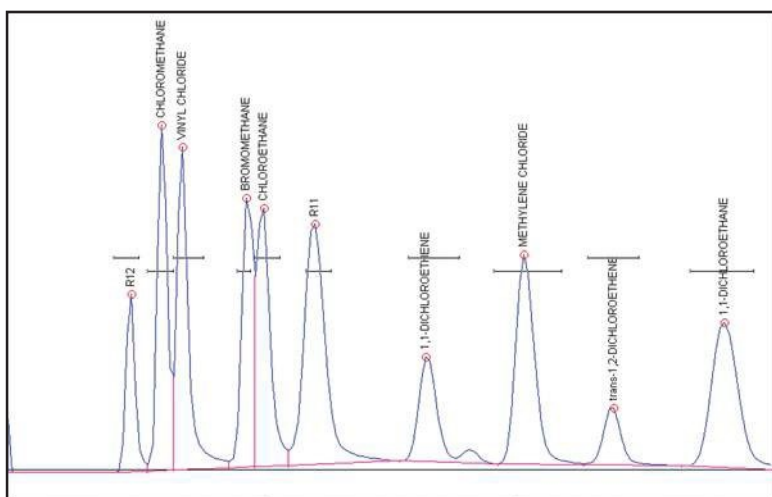

The first few peaks in the 8021 standard, including vinyl chloride, are of special interest to many analysts. The chromatogram to the left shows the expanded detail of the first few peaks in the analysis (the VOC gases). Note the exceptionally good resolution and peak shape delivered by the SRI system with its dual trap technology.

Please see page 68 for more information on the Method 5030/5035 Purge & Trap.

- 8610-0059**      **Environmental GC System**
- 8610-0050**      **BTEX GC: same as the Environmental GC, but with PID and FID detectors only (no DELCD detector)**
- 8690-5052**      **Upgrade to Method 5030/5035 compliant Purge & Trap**

OPTIONS & UPGRADES: Thermal Desorber, split/splitless and PTV injectors, NPD detector, additional column(s), autosampler  
 (VOLTAGE: for 115VAC, use "part number-1" [ex: 8610-0059-1] for 230VAC, use "part number-2")

# TO-14 Monitoring GC System

- Dual trap TO-14 Air Concentrator
- PID and combination FID/DELCD Detectors
- Vacuum pump and PeakSimple controlled Interface
- Built-in “whisper quiet” Air Compressor
- 6 channel PeakSimple Data System
- 60 meter Capillary Column
- ...on the compact 8610C chassis

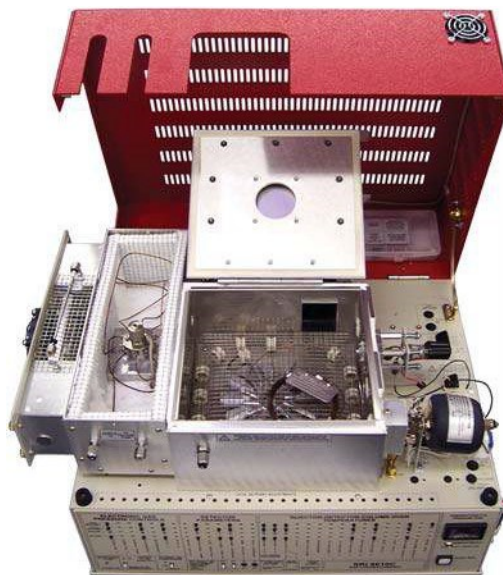

For TO-14 analysis and ambient air analyses of all types, this GC system has everything you need in a compact, easy-to-transport package.

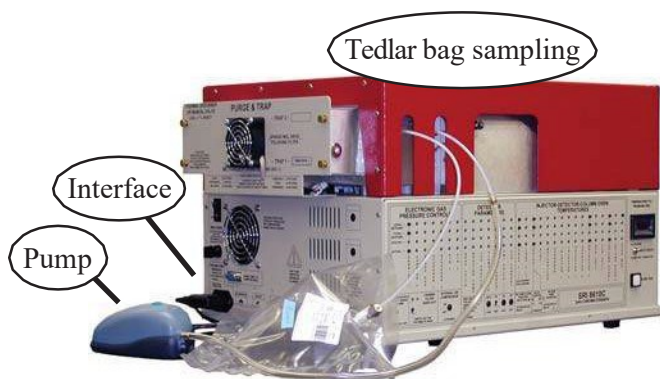

The dual-trap concentrator is similar to the SRI Purge & Trap, but has a gas inlet instead of a liquid purge vessel (a liquid purge head can be added if required). The innovative dual-trap design results in more efficient trapping and desorption than single trap designs, especially for early eluting peaks such as vinyl chloride. Please see page 61 for more information on the TO-14 Air Concentrator.

The 60 meter capillary column is the newest unbreakable, fused silica lined, stainless steel technology, which gives good separation of the TO-14 analytes with short run times. The PeakSimple data system controls and sequences the entire analysis, collecting the data from the three detectors, loading and desorbing the traps, then calculating and printing the results.

Since it is small enough to take on-site for real-time measurements, you can perform the analysis right at the source, avoiding the need for expensive, labor-intensive canister sampling. The vacuum pump interface allows the PeakSimple data system to turn the external vacuum pump ON/OFF under software control. The vacuum pump is used to draw ambient air through the traps for a precise amount of time, thus enabling the system to sample unattended. The built-in air compressor eliminates the hassle of transporting bulky air cylinders by providing an endless supply of combustion air for the FID/DELCD combination detector.

# TO-14 Air Monitoring GC System

The DELCD is completely selective for compounds containing chlorine and/or bromine. Other analytes do not respond at all, even at very high levels. The DELCD actually operates on the FID's exhaust gases; therefore, all contaminants are precombusted by the FID to CO<sub>2</sub> and H<sub>2</sub>O.

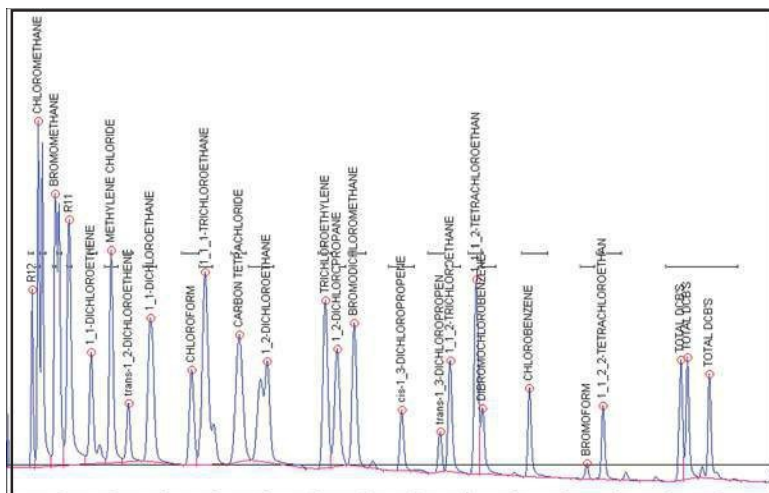

The first few peaks in the TO-14 standard, especially vinyl chloride, are of special interest to many analysts. This chromatogram shows the expanded detail of the first few peaks (the VOC gases) in the analysis shown above. Note the exceptionally good resolution and peak shape delivered by the SRI system's dual trap technology.

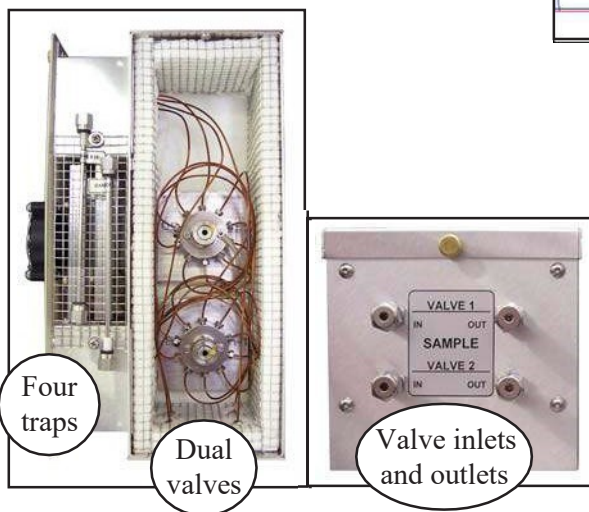
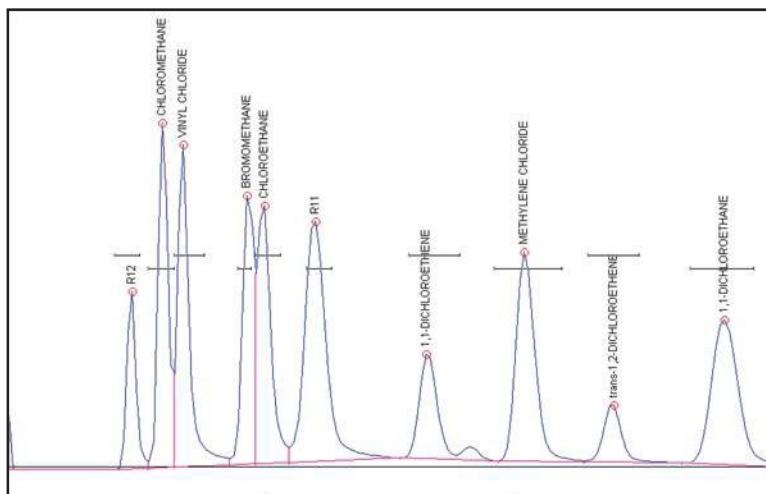

This SRI GC has been customized with a dual TO-14 Air Concentrator: four traps, and two gas sampling valves.

**8610-0114**

## TO-14 Air Monitoring GC System

OPTIONS & UPGRADES: split/splitless and PTV injectors, additional TO-14 Air Concentrator, additional detector, additional column(s)  
 (VOLTAGE: for 115VAC, use 8610-0114-1; for 230VAC, use 8610-0114-2)

# PCB GC System

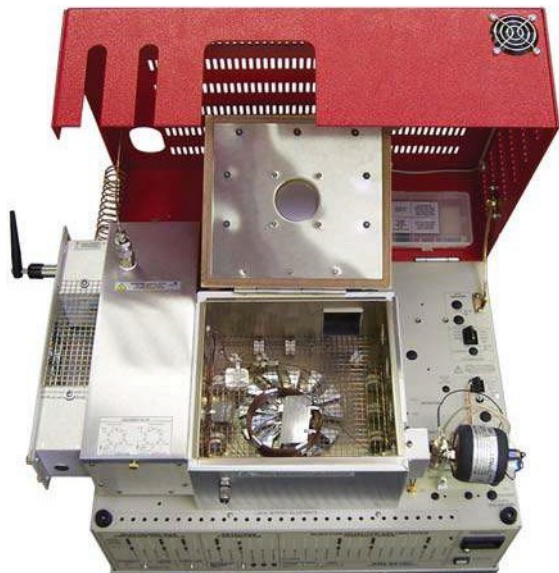

- Thermal Desorber
- 30 meter Capillary Column
- Built-in, "whisper quiet" Air Compressor
- 1 Channel PeakSimple Data System
- On-Column Injector
- ...on the compact 8610C chassis

The PCB GC System has everything you need to detect PCBs in soil and other solid matrices. The Thermal Desorber permits the user to inject and analyze PCBs with very high sensitivity and little or no sample preparation—no solvent extraction is required. Up to 1 gram of soil can be loaded into the reusable glass desorption tubes. For more information on the Thermal Desorber, please see page 66.

The FID detector responds to all hydrocarbons, and the DELCD identifies which are halogenated. Due to the extreme selectivity of the DELCD, PCBs can be discriminated even in the presence of massive hydrocarbon contamination. Because the FID precombusts the sample, the DELCD is protected from hydrocarbon contamination. The two chromatograms at right show the analysis of a 200ppm Aroclor 1254 sample in diesel with a PCB GC System.

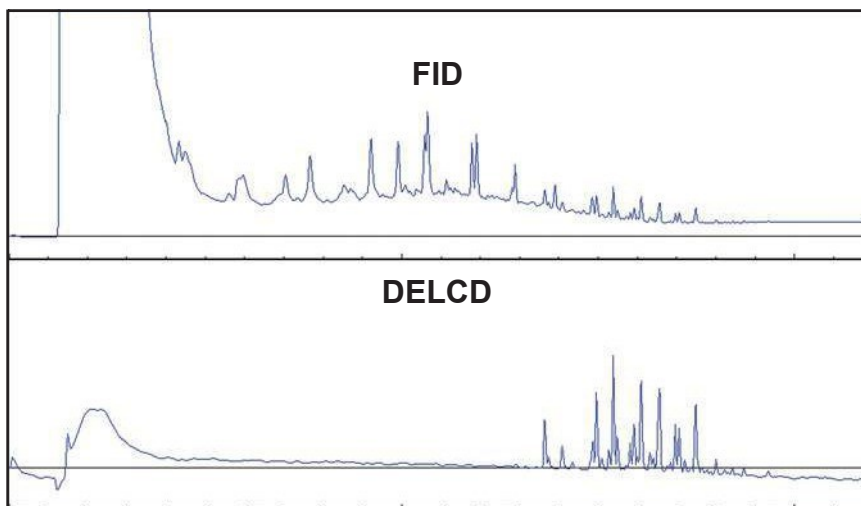

The PCB GC System is also useful for detecting pesticides, PAHs, JP-4, kerosene, and diesel in soil. Soil samples are typically 20-50% water, so the FID flame is automatically relit after a large water peak. The 30 meter capillary column is included to efficiently separate hydrocarbons up to C40+. The built-in, "whisper quiet" air compressor provides an infinite supply of combustion air for the FID detector.

**8610-0080**

## PCB GC System

OPTIONS & UPGRADES: additional detectors, split/splitless and PTV injectors.  
(VOLTAGE: for 115VAC, use 8610-0080-1; for 230VAC, use 8610-0080-2)

# Explosives GC System



- Thermionic Ionization Detector (TID)
- Heated Flash Vaporization Injector
- Built-in “whisper-quiet” AirCompressor
- 1 channel PeakSimple Data System
- Can be run gasless in the field!
- 15 meter Capillary Column
- ...on the compact 8610C chassis

The Explosives GC System from SRI combines a Heated Flash Vaporization Injector, a built-in “whisper-quiet” air compressor and a Thermionic Ionization Detector for detection of nitroaromatic explosives such as TNT, and nitramine explosives such as RDX (C<sub>4</sub>) and HMX.

If only the nitroaromatics are required, the GC will operate on the built-in air compressor’s air alone, using air for both carrier gas and make-up gas. This GC is especially convenient for field monitoring, and screening of explosives-contaminated soil and water, as might be found in former military bases or practice ranges.

Unlike immunoassay or colorimetric detection methods which cannot discriminate the biodegraded transformation byproducts of TNT (2-amino-4, 6-dinitrotoluene, etc.) and which may not function well in the presence of high levels of interferences from other explosive compounds, the Explosives GC can separate and detect all the nitroaromatic compounds, even in the presence of interferences that would compromise other measurement techniques. For TNT and some other nitroaromatics, detection limits of 1ppb are routine. When the nitroamines must also be detected, nitrogen is used for the carrier gas, and air is used for TID makeup gas. Nitramine compounds like RDX exhibit lower response by a factor of 50.

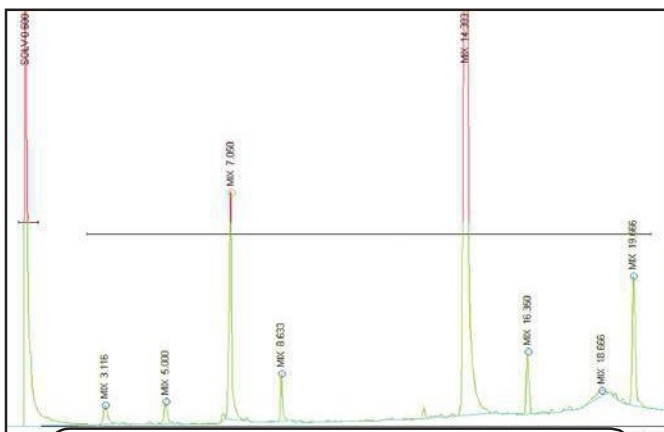

This chromatogram shows a separation of a 10ppm explosives mix using an Explosives GC.



**(ETV) program for measuring explosives in soil!**

**Tested by the EPA's Environmental Technologies Verification**

Download the ETV report and verification statement at [www.epa.gov/etv/verifications/vcenter1-4.html](http://www.epa.gov/etv/verifications/vcenter1-4.html)

Also, download “On-Site Characterization of Explosive Residues in Soils and on Range Scrap Using GC-TID Analysis” by Alan Hewitt of the US Army Corps of Engineers at [www.srigc.com](http://www.srigc.com)

8610-1117

Explosives GC System

# Rack Mount Mud-Logging GC System

- Dual FID Detectors
  - HayeSep-D Column
  - 10-port Gas Sampling Valve
  - Standard & Sample Stream Solenoids
  - Built-in “whisper quiet” Air Compressor
  - 6 Channel PeakSimple Data System
- ...on the rack mountable 410 chassis



The Rack Mount Mudlogging GC system provides a continuous reading of total hydrocarbons in a gas stream while periodically performing a chromatographic separation to determine the exact composition of the sample gas stream.

At a regulated pressure, the sample gas stream flows through the loop of the 10 port gas sampling valve and also to the second FID detector, which continually monitors the total hydrocarbon content of the gas. Periodically, the gas sampling valve injects the contents of its loop into the GC column, where it is separated into the constituent hydrocarbon peaks and detected by the first FID detector. The operator controls the timing of the valve injections through the built-in, six channel PeakSimple data system. Solenoids for sample and standard stream switching are included and are selectable through the data system.

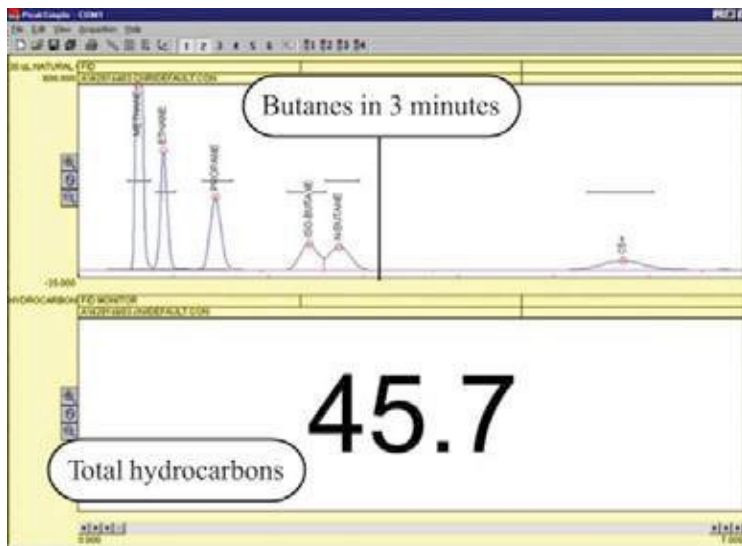

The PeakSimple data system controls the automated valve injection sequence and displays both the continuous total hydrocarbon reading as well as the separated peaks. An alarm function alerts the operator for any out-of-range readings. Summary reports are easily printed or copied to Excel or similar programs.

0410-0065

## Rack Mount Mud-Logging GC System

OPTIONS & UPGRADES: One-Minute Analysis  
(VOLTAGE: for 115VAC, use 0410-0065-1; for 230VAC, use 0410-0065-2)

# Gas-less™ Educational GC System



- CCD Detector
  - On-Column Injector
  - Built-in “whisper quiet” Air Compressor
  - 1 channel PeakSimple Data System
  - 1 meter HayeSep-D Column
- ...on the ultra compact 310 chassis

The Gas-less Educational GC system is ideal for demonstrating the principles of gas chromatography right in the classroom. The Gas-less Educational GC includes a built-in “whisper-quiet” air compressor and a CCD detector. The CCD detects combustible (hydrocarbon) molecules and it operates on air carrier gas from the internal air compressor.

This GC is perfect for teaching situations where compressed gas cylinders cannot be used due to safety considerations or budgetary limitations. Because it operates on its own infinite supply of room air, the Gas-less GC may be used to perform demonstrations in the classroom, instead of the lab. Most traditional GCs require helium carrier gas. Compared to the ongoing cost of cylinder rental, storage, and gas consumption, operation of the Gas-less Educational GC is essentially free, except for the minimal cost of electricity.

This chromatogram shows a separation of 1 $\mu$ L of 1000ppm methanol in acetone using a standard Gas-less Educational GC at 130°C.

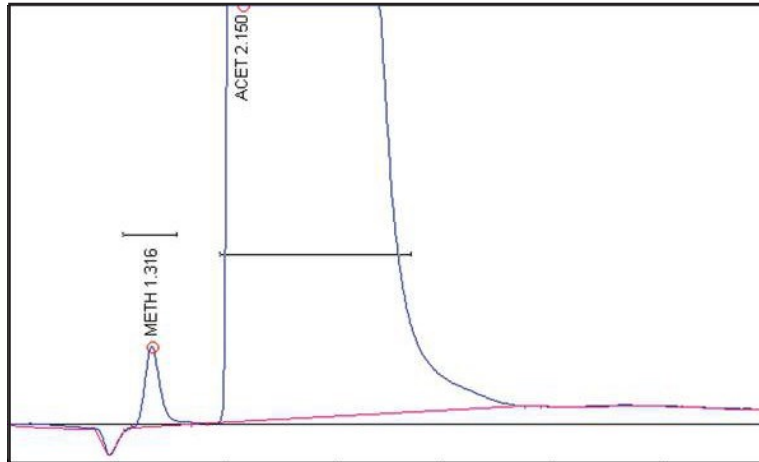

The Gas-less Educational GC is equipped with a built-in, single channel PeakSimple data system, which provides powerful yet easy data acquisition, as well as temperature programming for the column oven. Fast cool-down fans automatically cool the column oven at the end of the analysis from 250°C to 50°C in less than five minutes.

**0310-1006**

**Gas-less™ CCD GC System with fast cool-down**

(VOLTAGE: for 115VAC, use 0310-1006-1; for 230VAC, use 0310-1006-2)

NOTE: Educational models are less expensive than equivalent GCs manufactured “à la carte” because of batch manufacturing efficiencies. No customization of educational models is available prior to initial sale, although normal factory retrofit services are available after delivery.

# Educational TCD GC System



- TCD Detector with User Replaceable Filaments
  - Carrier Gas Electronic Pressure Control (EPC)
  - Temperature Programmable Column Oven
  - 1 channel PeakSimple Data System
  - 1 meter Silica Gel Column
- ...on the ultra compact 310 chassis

The Educational TCD GC is ideal for undergraduate chemistry classes where the principles of gas chromatography are demonstrated on equipment identical to what students will encounter in industry. Because of their low cost and upgradability\* with other SRI detectors and injectors, these GCs are also widely used by thrifty labs for simple applications such as landfill gas analysis, stack monitoring, and quality control.

Configured on the compact 310 chassis, the Educational TCD GC includes a traditional 4-filament Thermal Conductivity Detector that can heat to 275 °C. The built-in single channel PeakSimple data system provides powerful yet easy data acquisition and temperature programming for the column oven.

The column oven is temperature programmable up to 300 °C, and comes with fast cool-down fans. Electronic Pressure Control (EPC) for the carrier gas provides rock-solid retention time reproducibility.

These two similar chromatograms were produced under the same conditions. The first sample is room air, and the second is human breath. In both runs, the CO<sub>2</sub> peak is separated from the O<sub>2</sub>/N<sub>2</sub> peak at 80 °C on a standard Educational TCD GC with a Silica Gel column.

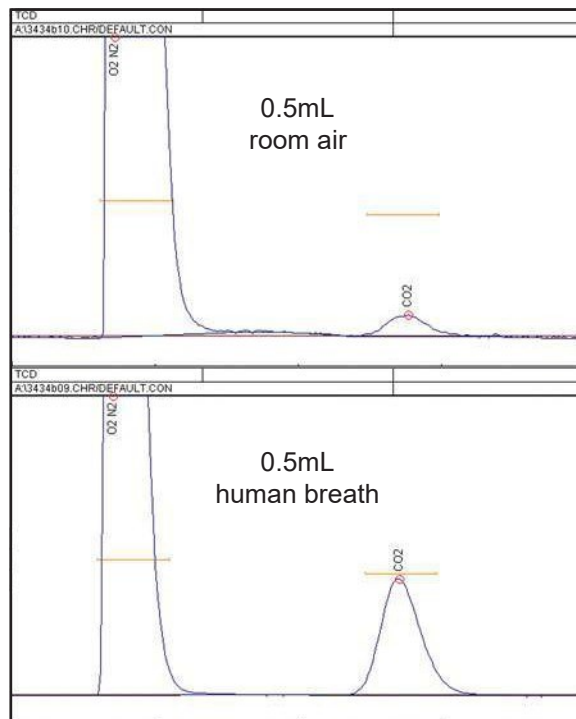

**0310-1000**

## Educational TCD GC System

(VOLTAGE: for 115VAC, use 0310-1000-1; for 230VAC, use 0310-1000-2)

\*Educational models are less expensive than equivalent GCs manufactured “à la carte” because of batch manufacturing efficiencies. No customization of educational models is available prior to initial sale, although normal factory retrofit services are available after delivery.



# Educational FID GC System



- FID Detector
  - On-Column Injector
  - Carrier & Combustion Gas Electronic Pressure Control (EPC)
  - Temperature Programmable Column Oven
  - 1 channel PeakSimple Data System
  - 1 meter Silica Gel Column
- ...on the ultra compact 310 chassis

The Gas-less Educational GC system is ideal for demonstrating the principles of gas chromatography right in the classroom. The Gas-less Educational GC includes a built-in “whisper-quiet” air compressor and a CCD detector. The CCD detects combustible (hydrocarbon) molecules and it operates on air carrier gas from the internal air compressor.

The carrier gas and the FID combustion gases are all controlled by programmable electronic pressure regulators (EPCs). EPCs not only provide rock-solid retention time reproducibility, but allow the carrier gas to be pressure ramped (just as the column oven is temperature ramped) from the built-in PeakSimple data system.

This chromatogram shows a separation of 1000ppm  $C_1$ - $C_6$  hydrocarbons in room air using the 1 meter silica gel column.

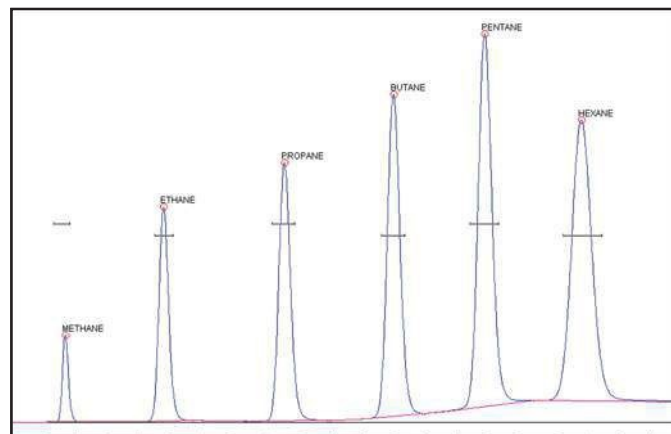

The on-column injector is ideal for 1/8” packed or 0.53mm wide-bore capillary columns and is suitable for analytes ranging from methane to heavy, high-boiling hydrocarbons ( $C_{44+}$ ). The column oven accepts column cage diameters up to 4 inches, is programmable up to 300°C and recycles quickly with its high speed cool-down fans.

## 0310-0004 Educational FID GC System

(VOLTAGE: for 115VAC, use 0310-0004-1; for 230VAC, use 0310-0004-2)

\*Educational models are less expensive than equivalent GCs manufactured “à la carte” because of batch manufacturing efficiencies. No customization of educational models is available prior to initial sale, although normal factory retrofit services are available after delivery.

# How to Build a Custom SRI GC

## 1. Pick a chassis

### WHAT IS YOUR APPLICATION?

- If you will be injecting by gas sampling valve, purge & trap, thermal desorber or any other injector types in addition to on-column, then choose our versatile Model 8610C, which can mount up to five different injectors simultaneously.



- If you will be injecting by syringe only, you can choose the ultra-compact Model 310.



- For dual oven applications or “two GCs in one,” choose the 8610D chassis.



- For industrial rack systems, choose our 410 rack mount chassis.



- For added compatibility with autosamplers and vertical injectors, choose the 8610V chassis.



- If you want to add detectors to an existing GC, choose the Model 110.



For any model chassis except the 110, you must specify the data system model you want. A single channel data system is included as standard equipment with the 8610, 410 and 310 GCs. If you'll be ordering more than one detector on your GC, you will need a six channel data system.

## 2. Choose your detectors

Detector types are selected depending on the particular application, the required detection limit, matrix interferences and/or regulatory guidelines. Since all five of our chassis can mount up to four (sometimes five or six) detectors simultaneously, you can perform a surprising variety of applications with one instrument.

DETECTOR	SELECTIVITY	SENSITIVITY (approx.)
CCD	hydrogen and hydrocarbons	500ppm
TCD	universal	200-500ppm
FID	hydrocarbons	1ppm
DELCD	chlorinated and brominated molecules	10ppb
FID/DELCD	hydrocarbons, chlorinated and brominated molecules	10ppm
HID	universal, except neon	10ppm
PID	aromatics and molecules with double carbon bonds	10ppb
NPD	nitrogen and phosphorus	100ppb
TID	nitro functional groups (TNT, etc.), chlorinated phenols at slightly less sensitivity	10ppb, 50ppb
ECD	electronegative compounds (esp. chlorinated, fluorinated, or brominated molecules)	10ppb
FPD	sulfur and phosphorus	200ppb and 10ppb
FPD/FID	sulfur, phosphorus and hydrocarbons	200ppb, 10ppb, and 100ppm
Dual FPD	sulfur and phosphorus simultaneously	200ppb and 10ppb
FID Dual FPD	hydrocarbons, sulfur and phosphorus simultaneously	100ppm, 200ppb and 10ppb

## 3. Choose your injectors

Injector types are selected by the user depending on the particular measurement application, detection limit and regulatory requirements. Twelve injector types are available for installation on SRI GCs. Up to five injectors may be mounted simultaneously on the Model 8610C or 8610D. The Model 310 will accommodate a single On-column, Heated Flash Vaporization, Heated Split/Splitless, or PTV Injector. The On-Column Injector is standard equipment on every 8610C, 8610D and 310 GC. Heated Flash Vaporization, Heated Split/Splitless and PTV Injectors are all upgrades to the standard On-Column Injector. A vertical injector option is available on the 8610V.

SAMPLE TYPES AND APPROPRIATE INJECTORS	
<b>LIQUIDS</b>	<ul style="list-style-type: none"> <li>On-column, Heated Split/Splitless, Heated Flash Vaporization, PTV, Heated Static Headspace, Purge &amp; Trap, Liquid Injection Valve, Liquid Autosamplers, or Headspace Autosampler</li> </ul>
<b>SOLIDS</b>	<ul style="list-style-type: none"> <li>Thermal Desorber, Heated Static Headspace, PTV, or Headspace Autosampler</li> </ul>
<b>GASES</b>	<ul style="list-style-type: none"> <li>On-column, Gas Sampling Valve, Method TO-14 Air Concentrator, or Heated Static Headspace</li> </ul>
<b>SPME FIBERS</b>	<ul style="list-style-type: none"> <li>Heated Flash Vaporization with Low Volume SPME Liner, or Heated Split/Splitless</li> </ul>

## 4. Accessorize

Our built-in, “whisper quiet” air compressor can supply air carrier gas or detector makeup gas.



Gas Line Installation Kits for any type of gas required for SRI GC operation.

The Methanizer accessory allows FID detection of CO and CO<sub>2</sub> down to ppm.



Although many injectors and detectors can be built into every GC chassis, there are instances where certain components would occupy the same space, or we just run out of room. If you are not sure if everything you want will fit, call one of our knowledgeable technical support agents for help.

# SRI Gas Chromatograph Overview



The full-featured Model 8610 GC can mount up to four detectors, five injectors and a host of accessories, yet is still small enough to ship UPS/FedEx or even carry with you on your expeditions into the field. It also fits easily on your crowded laboratory bench.



The Model 8610D is identical to the 8610C except that it has dual temperature programmable column ovens.



The 8610V GC is a vertical oven version of the 8610C which interfaces to most autosamplers.



The compact Model 310 can mount four detectors and one injector. Consider this GC when you want the smallest laboratory GC available and plan to inject using a syringe.



Choose the rack-mountable Model 410 for standard 19-inch industrial rack systems.



The ultra-compact Model 110 can mount up to four detectors and connects to a host GC (SRI or another brand) via a heated transfer line. Pick this model when you need to add detectors to an existing GC or want GC detector performance without a chromatographic separation (total hydrocarbon stream monitoring, etc).



## Standard Features of All SRI GC Models:

- Built-in, single channel PeakSimple data system
- Heavy-duty, all-aluminum construction for lightweight durability.
- “At-a-glance” panel display that reports the status of system heating, pressure, and voltage control zones to the bright and easy-to-read display.
- Electronic Pressure Control (EPC) for all regulated gas pressures. EPC results in enhanced day-to-day reproducibility compared to mechanical pressure regulators and allows the carrier gas pressure to be ramped from the data system.
- Four, five or six simultaneous detector capability—choose from 16 detector types.
- Two year warranty and FREE technical support.
- Rugged reusable plastic container which ships UPS/FedEx. The GC is secured in the shipping container using a system of belts and buckles which eliminates the need for extra styrofoam peanuts, bubble wrap and other annoying packaging materials.

Since the typical GC weighs about 60lbs in the shipping container, it is easily carried by one person.

## GC Column Oven Options

Three temperature programmable oven types are available for SRI GCs:

1. The large air bath column oven comes standard on the 8610C chassis. This oven will accommodate a single column on a seven inch diameter cage, or multiple columns coiled on smaller cages or bundled without a cage. This oven is rated to 400°C and is equipped with a 600 watt heater and fast cool-down fans.



2. The 8610V column oven is temperature programmable from ambient to 400°C with unlimited ramps and holds, and fast cool-down. The larger oven accommodates multiple columns and detectors.



3. The small air bath column oven comes standard on the Model 310 chassis. This oven will fit multiple columns coiled within five inches diameter (3.5" or 4" coil size preferred). This oven is also rated to 400°C and is equipped with a 600 watt heater and fast cool-down fans. With the same heater wattage and cool down fans as the large oven in a smaller volume, this oven heats and cools faster. Dual, independently programmable small air bath ovens are installed on the Model 8610D GC chassis. The second oven is 4.5" wide, so only columns coiled smaller than four inches in diameter can be used.



# Model 8610C Gas Chromatograph

- Mounts up to Six Detectors and Five Injectors
- Ambient to 400°C Temperature Programmable Column Ovens
- Dimensions: 19" wide x 13.5" high x 14.5" deep
- Implement virtually any EPA or ASTM method

The Model 8610C Gas Chromatograph is our most versatile and popular model. While it is very compact next to comparable laboratory GCs from other manufacturers, it is large and flexible enough to perform an amazing variety of applications. See our Preconfigured GC section (starting on page 3) for examples of the 8610C adaptability.



Up to six detectors can be installed on the same 8610C GC.



ECD

PID

FID / DELCD

FPD

# Model 8610C Gas Chromatograph

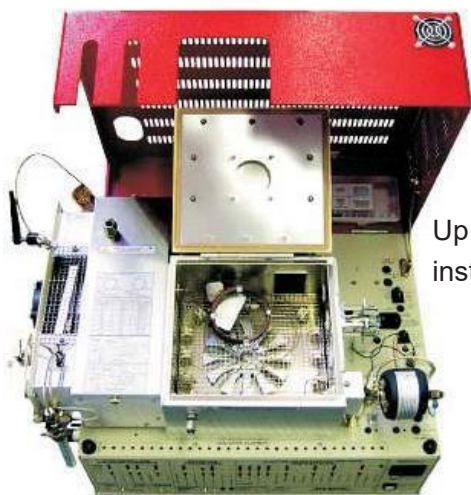

Up to five injectors can be installed on the same GC.

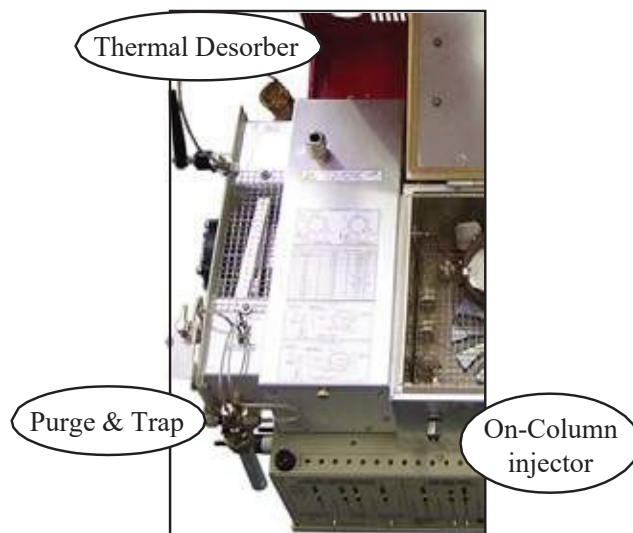

The 8610C column oven is temperature programmable from ambient to 400°C with unlimited ramps and holds, and fast cool-down. This airbath oven can hold a standard seven inch diameter megabore column cage or multiple columns with smaller coil sizes.

The 8610C chassis can be configured to implement virtually any EPA or ASTM method while remaining small enough to ship via FedEx. A reusable shipping crate comes with every GC.



## Standard Equipment:

Model 8610C chassis; ambient to 400°C column oven; On-Column injector with carrier EPC; PeakSimple data system; “at-a-glance” display of temperatures, pressures, voltages and detector parameters; operator’s manual; accessory kit; heavy duty re-useable shipping container. To completely configure a Model 8610C GC, most users will need to specify one or more detectors, injectors and columns. Some users may also need a Gas Line Installation Kit (see page 77) for each gas required (helium, hydrogen, nitrogen, etc.).

**8610-1003**      **Model 8610C chassis with 1 channel USB PeakSimple data system**

**8610-6003**      **Model 8610C chassis with 6 channel USB PeakSimple data system**

VOLTAGE: for 115VAC, use “part number-1” [ex: 8610-1003-1] for 230VAC, use “part number-2”

# Model 8610D Dual Oven Gas Chromatograph

- Dual Ambient to 400°C Temperature Programmable Column Ovens
- Dimensions: 19" wide x 13.5" high x 14.5" deep
- Mounts up to Six Detectors and Five Injectors

The Model 8610D Gas Chromatograph is the only commercially available dual oven GC. It is similar to the 8610C, except that two smaller column ovens are substituted for the larger 8610C column oven. Both of the dual ovens are independently temperature programmable from ambient to 400°C, with unlimited ramps and holds, plus fast cool-down. Each 8610D column oven can accommodate a four inch diameter wound column, capillary or packed. Almost all column manufacturers now supply columns of this size. The dual column ovens can be used to accomplish sophisticated multidimensional GC separations, where the peaks eluting from one column are transferred to another column for further separation. The dual ovens can be used to double sample throughput for “two GCs in one” cost and space savings.



Standard equipment:

Model 8610D chassis; dual ambient to 400°C column ovens; On-Column injector (oven #1 only) with carrier EPC; single channel PeakSimple data system; “at-a-glance” display of temperatures, pressures, voltages, and detector parameters; operator’s manual; accessory kit; heavy duty reuseable shipping container. To completely configure a Model 8610C GC, most users will need to specify one or more detectors, injectors, and columns. Some users may also need a Gas Line Installation Kit (see page 77) for each gas required (helium, hydrogen, nitrogen, etc.).

**8610-1004**      **Model 8610D chassis with 1 channel USB PeakSimple data system**

**8610-6004**      **Model 8610D chassis with 6 channel USB PeakSimple data system**

VOLTAGE: for 115VAC, use “part number-1” [ex: 8610-1004-1] for 230VAC, use “part number-2”



# Model 8610V Gas Chromatograph

## and 121-Vial Autosampler



- Ambient to 400°C Temperature Programmable Column Oven
- Unlimited Ramps and Holds
- Multiple Columns and Detectors

The Model 8610V Gas Chromatograph is one of our most popular models. While it is very compact next to comparable laboratory GCs from other manufacturers, it is large enough and flexible enough to perform an amazing variety of applications. The 8610V column oven is temperature programmable from ambient to 400 °C with unlimited ramps and holds, and fast cool-down. The larger oven accommodates multiple columns and detectors.

The all electric sample system eliminates air bubbles, and the variable fill speed allows for a wide range of sample viscosities. The syringe may be washed with solvent or sample.

### AUTOSAMPLER FEATURES

- Holds 110 2mL vials
- Methods Linking
- Multi-Step Automatic Injection Sequence
- Direct Injection, No Transfer Lines

### MEMORY OPTIONS

- Analytical method
- Number of injections for each sample
- Pre and Post washing solvent position
- Internal standard position (if used)

The Autosampler is made to meet the high throughput injection needs of your GC analysis. The swivel head design simulates the movements of manual direct injection and eliminates the need for transfer lines, as well as leaving the injection port free for manual injections. Up to 10 analytical methods may be stored in the Autosampler memory.

Let us help you custom configure your 8610V to implement virtually any EPA or ASTM method

**8610-2003**

**Model 8610V Gas Chromatograph with vertical injector 1 Channel USB**

**8610-7003**

**Model 8610V Gas Chromatograph with vertical injector 6 Channel USB**

**Model 8610V HTA 110-Vial Autosampler**

VOLTAGE: for 115VAC, use "part number-1" [ex: 8610-2003-1] for 230VAC, use "part number-2"

## Model 310 Gas Chromatograph



- Small size, full performance
- Dimensions: 12.5" wide x 13.5" high x 14.5" deep
- Ambient to 400°C Temperature Programmable Column Oven
- Mounts up to Four Detectors

The Model 310 Gas Chromatograph is the smallest GC which still retains the performance of a full-sized laboratory instrument. The Model 310 column oven is temperature programmable from ambient to 400°C, with unlimited ramps and holds, plus fast cool-down. The column oven will accommodate four inch diameter columns, capillary or packed. Up to four detectors can be mounted simultaneously with a single On-Column, Heated Flash Vaporization, Split/Splitless or PTV injector. All gases are controlled by electronic pressure controllers (EPC), and the carrier pressure is programmable. The PeakSimple data system is built in for easy connection to your PC. The Model 310 was designed to satisfy the needs of chromatographers who demand the utmost in portability, small size and high performance, but whose application does not require gas sampling valves, purge & trap, or multiple injector types.

### Standard equipment:

Model 310 chassis; ambient to 400°C column oven; On-Column injector with carrier EPC; single channel PeakSimple data system; "at-a-glance" display of temperatures, pressures, voltages, and detector parameters; operator's manual; accessory kit; heavy duty reuseable shipping container. To completely configure a Model 310 GC, most users will need to specify one or more detectors, a column, and an injector upgrade. Some users may also need a Gas Line Installation Kit (see page 77) for each gas required (helium, hydrogen, nitrogen, etc.).

**0310-1003**      **Model 310 chassis with 1 channel USB PeakSimple data system**

**0310-6003**      **Model 310 chassis with 6 channel USB PeakSimple data system**

VOLTAGE: for 115VAC, use "part number-1" [ex: 0310-0003-1] for 230VAC, use "part number-2"

# Model 410 Rackmount Gas Chromatograph

- Multiple Detector Capability
- Optional Gas Sampling Valve
- For Industrial Gas Sampling applications
- Fits Shelf-equipped 19-inch Racks



The Model 410 Rack-Mount GC is a compact, rack mountable instrument which offers the performance of a full-sized laboratory gas chromatograph. Excellent for industrial applications, or any facility without benchtop workspace, the Model 410 mounts in standard 19-inch racks. It can mount multiple detectors, a single On-Column, Heated Flash Vaporization, Split/Splitless or PTV injector and a gas sampling valve. The column oven will accommodate four inch diameter columns, capillary or packed. All gases are controlled by electronic pressure controllers (EPC) and the carrier gas pressure is programmable. With the built-in PeakSimple data system, all that is needed to connect the GC to your computer is a serial or USB cable, depending upon the data system option selected. The Model 410 Rack-Mount GC features the familiar, easy-to-read SRI display panel and mounts on your existing sliding shelf for accessibility.

## Standard equipment:

Model 410 chassis; ambient to 400°C column oven; On-Column injector with carrier EPC; single channel PeakSimple data system; “at-a-glance” display of temperatures, pressures, voltages, and detector parameters; operator’s manual; accessory kit; heavy duty reuseable shipping container. To completely configure a Model 410 GC, most users will need to specify one or more detectors, a column, and an injector upgrade. Some users may also need a Gas Line Installation Kit (see page 77) for each gas required (helium, hydrogen, nitrogen, etc.). This system does not include the rack itself.

**0410-1000      Model 410 chassis with 1 channel USB PeakSimple data system**

**0410-6000      Model 410 chassis with 6 channel USB PeakSimple data system**

VOLTAGE: for 115VAC, use “part number-1” [ex: 0310-0003-1] for 230VAC, use “part number-2”

## Model 110 Stand-alone Detector Chassis



- Add up to Four Detectors to Any GC
- Dimensions: 8.5" wide x 13.5" high x 14.5" deep
- Heated Transfer Line for connection to Host GC

The Model 110 Chassis can be configured as a stand-alone detector chassis, capable of mounting any combination of up to 4 detectors. The Model 110 is equipped with a heated transfer line for connection to the host GC, from SRI or any other manufacturer. The heated transfer line requires only a small hole in the host GC's column oven, so the 110 makes it easy to add detectors even to older units that are out of production. The fused silica lined, metal heated transfer line operates at 200°C, which is hot enough for most applications. However, analysis of high boiling analytes may not be possible if they could condense in the line at this temperature. For those detectors that require support for gases such as hydrogen or air, the 110 is equipped with electronic pressure controllers (EPC) for each gas. An optional "whisper quiet" air compressor may be installed to provide air for FID, DELCD, and/or FPD detectors. The standard Model 110 is equipped with analog signal cable output (0-5V) for connection to your data system, integrator or strip chart recorder. A single channel or six channel PeakSimple data system may be installed for PC-based data acquisition.

The Model 110 chassis has been used for a variety of unique custom solutions. Please contact us regarding your application needs.

Standard equipment:

Model 110 chassis; heated transfer line; "at-a-glance" display of detector temperatures, pressures, and voltages; analog signal cable for connection to data system; operator's manual; accessory kit; heavy duty reuseable shipping container. To completely configure a Model 110 GC, most users will need to specify one or more detectors to be mounted on the chassis.

**0110-0003 Model 110 chassis with Standard Equipment**

VOLTAGE: for 115VAC, use "part number-1" [ex: 0110-0003-1] for 230VAC, use "part number-2"

## GC Detector Overview (16 Types)



Each detector is equipped with Electronic Pressure Controlled (EPC) support gases, such as hydrogen and air for the FID, a thermostatted heater block for temperature stability, and internal amplifier electronics. All detectors require factory installation. Prices listed are for the detector mounted on an SRI chassis.

1. **CCD - Catalytic Combustion Detector**
2. **TCD - Thermal Conductivity Detector**
3. **FID - Flame Ionization Detector**
4. **DELCD - Dry Electrolytic Conductivity Detector**
5. **FID/DELCD - Combination FID and Dry Electrolytic Conductivity Detector**
6. **HID - Helium Ionization Detector**
7. **PID - Photo Ionization Detector**
8. **NPD - Nitrogen-Phosphorus Detector**
9. **NPD/DELCD - Combination NPD and DELCD Detector**
10. **TID - Thermionic Ionization Detector**
11. **FPD - Flame Photometric Detector**
12. **FPD/FID - Combination FPD and FID Detector**
13. **Dual FPD - Dual Wavelength for both Sulfur and Phosphorus**
14. **FID Dual FPD - Dual FPD plus FID Combination Detector**
15. **ECD - Electron Capture Detector**
16. **RGD - Reduction Gas Detector**

Detector types are selected by the user depending on the particular measurement application, detection limit required, matrix interferences and regulatory guidelines. Some rare combinations of detectors may conflict due to space limitations.

# CCD - Catalytic Combustion Detector

- Detects Down to 500ppm
- Hydrocarbon and Hydrogen Selective
- Gasless Operating Capability
- Inexpensive and Rugged
- Built-in Spare!

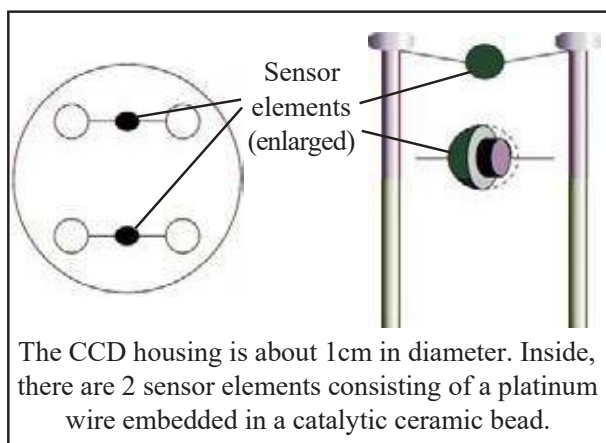
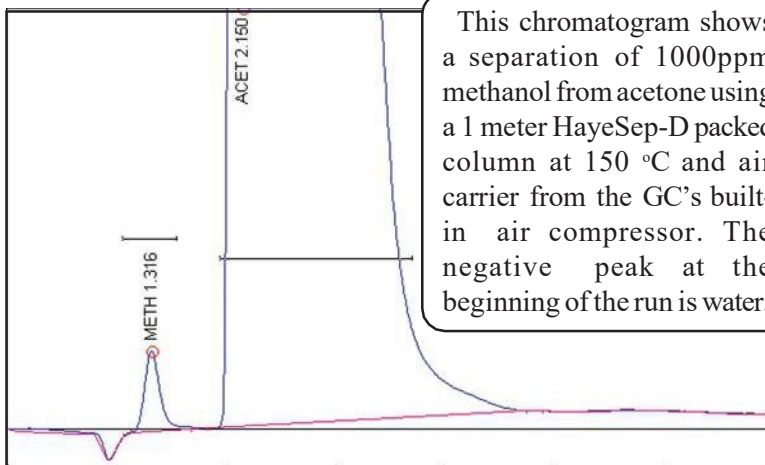

The CCD is about as sensitive as a TCD, but it has the hydrocarbon selectivity of an FID while capable of operating on air alone. Because the CCD needs no compressed gases like hydrogen or helium, it can be used in SRI's Gas-less™ GCs where a built-in, "whisper quiet" air compressor supplies the ambient air carrier gas.

The CCD can also be used as a hydrocarbon monitor in nonchromatographic applications where the CCD senses the total hydrocarbon content of a flowing air stream, or as a hydrogen/hydrocarbon leak detector.

The CCD detector sensor is rugged and can be expected to last a long time. A second sensor is included in the detector housing at no extra cost, providing a built-in replacement should the first sensor become inoperable. Replacement sensor sets install in minutes without tools and are very economical, making this detector a good choice for academic settings where the detector may be damaged by inexperienced operators.

The Catalytic Combustion Detector consists of a tiny coil of platinum wire embedded in a catalytic ceramic bead. A small electric current flows through the platinum coil, heating the ceramic bead to around 500°C. The CCD is maintained in an oxidative environment typically by using air carrier gas. When a hydrogen or hydrocarbon molecule impacts the hot bead, it combusts on the surface and raises the temperature and resistance of the platinum wire. This resistance change causes the detector output signal to change, thus producing a peak. The brass detector housing is mounted on a stainless steel bulkhead fitting, which is secured directly to the wall of the GC column oven.

8690-2007

CCD detector

8670-2007

Replacement CCD detector housing (2 sensors in 1 housing)

# TCD - Thermal Conductivity Detector

- “Universal” Detector
- Detects from 100% Down to 200-500ppm
- Easily Replaceable Filaments
- Thermostatted up to 275°C

Our TCD is equipped with user-replaceable filaments, so it can be quickly returned to service in the event of a burnout.

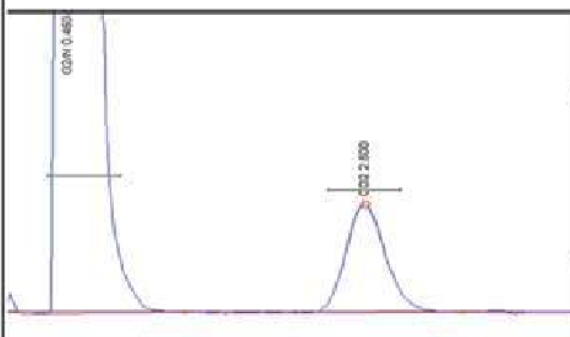

This chromatogram shows CO<sub>2</sub> at 10,000ppm (11%) in a 100% methane flow rate using a one meter Silica gel packed column at 80°C.

Because it detects all molecules, the Thermal Conductivity Detector is commonly used for fixed gas analysis (O<sub>2</sub>, N<sub>2</sub>, CO, CO<sub>2</sub>, H<sub>2</sub>S, NO, NO<sub>2</sub>, etc.) where the target analytes do not respond well on other, more sensitive detectors. The TCD can detect concentrations from 100% down to around 100ppm on a flat baseline with sharp peaks. Where the peak is broad or the baseline is not perfectly flat, detection limits of 300ppm are more realistic. For lower detection limits, the HID may be more suitable for inorganics, while the FID provides 1ppm detection for hydrocarbon species.

The TCD consists of four tungsten-rhenium filaments in a Wheatstone bridge configuration. Electric current flows through the filaments, causing them to heat up. Carrier gas (typically helium, which has very high thermal conductivity) flows across the filaments, removing heat at a constant rate. Two of the filaments are exposed only to carrier gas (reference), and two are exposed to the carrier/sample flow. When a sample molecule with lower thermal conductivity than the carrier gas exits the column and flows across the two sample filaments, the temperature of the filaments increases. This temperature increase unbalances the Wheatstone bridge and generates a peak as sample molecules transit through the detector.

A filament protection circuit prevents filament damage by disabling the current if carrier pressure is not detected by the GC, but cannot prevent filament damage under all circumstances. The TCD is equipped with user-replaceable filaments in the event of a burnout.

8690-0007

TCD detector

# FID - Flame Ionization Detector

- Hydrocarbon Selective
- Robust, Linear, Stable
- Detects Down to 1ppm
- Unique Ceramic Ignitor can run HOT continuously to keep flame lit

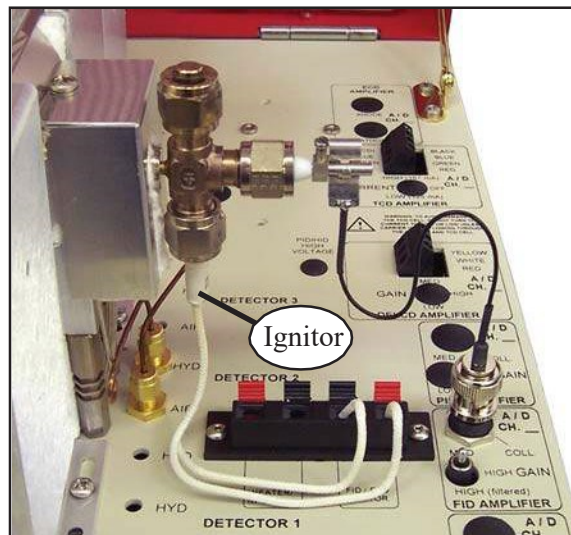

The Flame Ionization Detector is the most commonly used GC detector, responding linearly from its minimum detectable quantity of about 100 picograms to almost 100%.

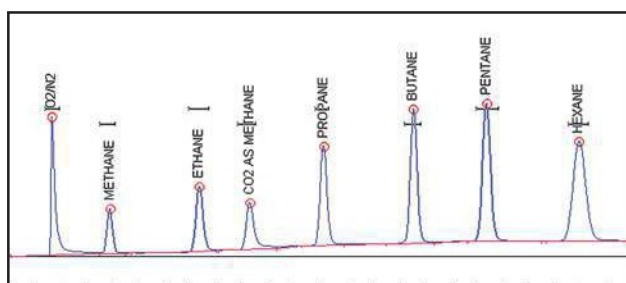

This chromatogram shows 250ppm C<sub>1</sub>-C<sub>6</sub> hydrocarbons (methane through hexane) standard as detected by the FID. CO<sub>2</sub>, also at 250ppm, is converted to methane by the Methanizer accessory in the jet of the FID detector.

The FID responds to any molecule with a carbon-hydrogen bond, but not at all, or poorly, to compounds such as H<sub>2</sub>S, CCl<sub>4</sub> or NH<sub>3</sub>. The FID response is very stable from day to day, and is not susceptible to contamination from dirty samples or column bleed.

The SRI FID employs a unique ceramic ignitor which can run hot continuously, immediately reigniting the flame even when presented with large water injections or pressure surges from column backflush.

The FID is thermostatted in an aluminum block up to 600°C, and is equipped with an electrometer amplifier with HIGH, HI-FILTERED (for extra noise immunity), and MEDIUM gain settings. Hydrogen and air flow are controlled using Electronic Pressure Controllers (EPC) for high precision. The optional built-in, “whisper quiet” air compressor can be used to supply the air for the FID, eliminating the bulky air cylinder.

If CO and CO<sub>2</sub> are target analytes, order our Methanizer accessory (page 74) for the FID detector. The Methanizer allows the FID to detect low levels of CO and CO<sub>2</sub> by converting them to methane without changing their retention times. Thermostatted to 380°C, the Methanizer is a special catalyst jet which can be removed for normal FID operation.

8690-0010	FID detector
8690-0082	Methanizer Jet for low level CO & CO <sub>2</sub>
8690-0070	Optional 115VAC 60Hz built-in “whisper quiet” air compressor
8690-2270	Optional 230VAC 50Hz built-in “whisper quiet” air compressor



# DELCD - Dry Electrolytic Conductivity Detector

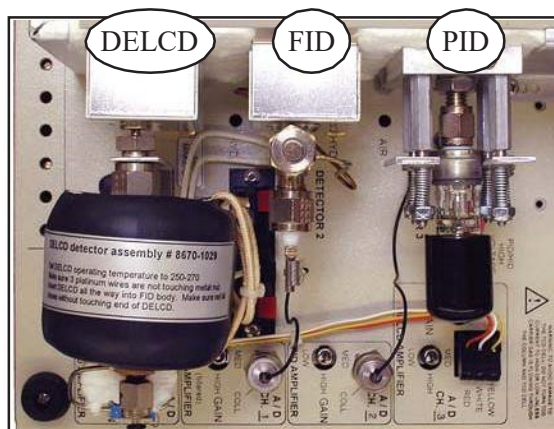

- Nonradioactive alternative to ECD!
- High Sensitivity—Detects down to 10ppb
- Selective to Chlorinated and Brominated molecules
- Best used with Headspace or Purge & Trap injectors
- Can be Combined with FID, NPD, or TID detectors

The DELCD is useful for low-level detection of chlorinated and brominated solvents in environmental samples and other trace analyses. In the picture above, a DELCD is mounted next to FID and PID detectors on an SRI GC. The three chromatograms below are from a similar SRI GC.

The Dry Electrolytic Conductivity Detector possesses sensitivity much like the ECD, except it is more selective to halogens and blind to oxygen. The SRI DELCD differs from the traditional wet ELCD in that it does not use a solvent electrolyte or nickel reaction tube, and the reaction products are detected in the gaseous phase. In the high sensitivity mode (no hydrogen, using dry tank air), the DELCD can detect down to the low picogram range. In this mode, the DELCD is about 100 times more sensitive than the FID/ DELCD. However, the high sensitivity DELCD is susceptible to contamination from high concentrations of chlorinated hydrocarbons and hydrocarbon solvents.

A 50ppb Japanese VOC standard was placed into a VOA vial with water, then allowed to equilibrate at room temperature for 45 minutes before 1mL of the headspace was injected. The FID chromatogram shows all the components and the solvent. The DELCD does not respond to the solvent, and the PID does not detect the 1,1,1-TCA.

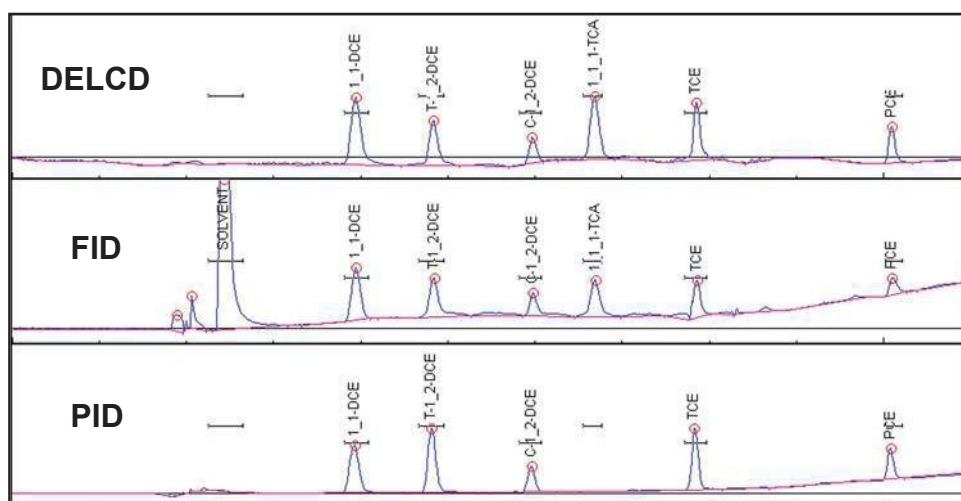

8690-1026

DELCD detector

# FID/DELCD Combination Detector

- The FID detects Hydrocarbons and the DELCD identifies which are Halogenated
- No Electrolytes needed for the DELCD
- High and Low sensitivity modes
- Detects to the Low ppm range

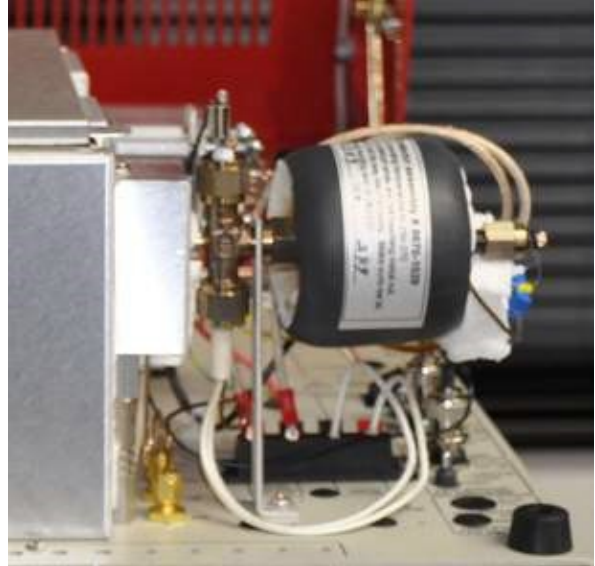

The FID/DELCD is one of the most useful detector combinations because it allows the operator to reliably identify hydrocarbon peaks detected by the FID as halogenated or not

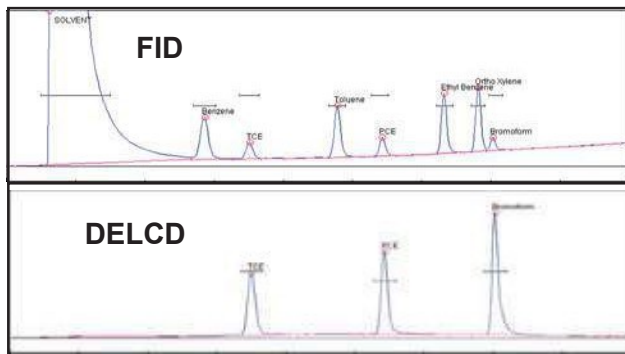

The top FID trace shows the hydrocarbons in a 100ppm BTEX plus sample, while the bottom DELCD trace shows only the halogenated compounds. The DELCD completely rejects the large solvent peak.

While less sensitive than the ECD detector, the DELCD is much more selective, eliminating interferences which would complicate an ECD analysis. Sample preparation which might be required for ECD work is not required for the DELCD because of its total selectivity to chlorine and bromine, and because the FID pre-combusts any contaminants. In the high sensitivity mode (hydrogen off, using dry tank air), the DELCD can detect down to the low picogram range. In this mode, the DELCD is about 100 times more sensitive than when used with the FID exhaust in the low sensitivity mode.

The DELCD measures the  $\text{ClO}_2$  present in the FID exhaust gas. Because the FID combusts the sample upstream of the DELCD, all hydrocarbons are converted to  $\text{CO}_2$  and  $\text{H}_2\text{O}$  prior to the DELCD, thereby completely preventing large hydrocarbon peaks from contaminating the DELCD. Because the DELCD operates at close to  $1000^\circ\text{C}$ , it can tolerate the water saturated FID effluent and measure the chlorine or bromine content simultaneously with the FID hydrocarbon content measurement. This is especially beneficial for measuring chlorinated VOCs under a solvent peak, or in measuring PCB peaks obscured under large amounts of diesel fuel. This detector combination is often used with our Thermal Desorber or Purge & Trap, which concentrate the sample to achieve lower detection limits.

8690-2026

FID/DELCD detector

# HID - Helium Ionization Detector

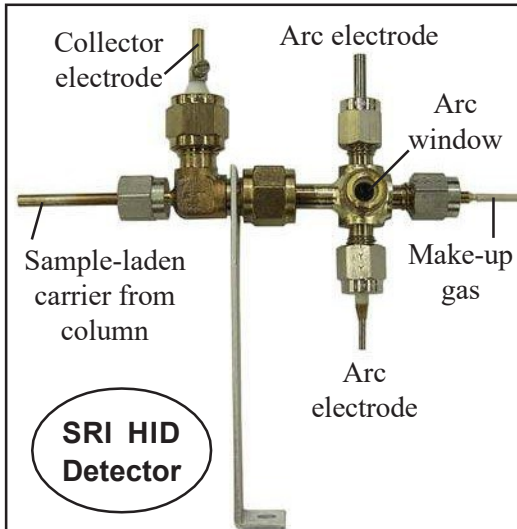

- Universal (except neon)
- Detect from 1-2% down to 10ppm
- Requires only helium carrier and make-up gas
- Perfect Complement to the TCD!

The Helium Ionization Detector is a “universal” detector which responds to all molecules except neon. The HID is particularly useful for volatile inorganics like NO<sub>x</sub>, CO, CO<sub>2</sub>, O<sub>2</sub>, N<sub>2</sub> and H<sub>2</sub> which do not respond on the FID or other detectors. Unlike an FID, the HID needs no hydrogen or air. The HID requires only helium carrier and make-up gas, and delivers sensitivity in the low ppm range. Many labs are reluctant to store hydrogen fuel gas for safety reasons, so the fact that the HID requires only helium is a significant advantage.

The HID is especially useful in combination with a Thermal Conductivity Detector. The TCD is not sensitive enough to detect low ppm concentrations, while the HID saturates in the low percent range. When using both detectors in series, it is possible to cover 10ppm to 100%.

Unlike other HID designs, the SRI HID can be heated to 350°C and can easily be disassembled for cleaning. The HID incorporates robust, easily serviceable electrodes which support a low current arc through the helium make-up gas flow. This elevates the surrounding helium to a metastable state. When the metastable helium molecules collide with sample molecules as they elute from the column, the sample molecules are ionized and attracted to a collector electrode, amplified, and output to the data system. Our HID features a window through which the low current arc is visible, so it is easy for the operator to verify that the detector is functioning.

This chromatogram shows the separation of a 100ppm BTEX Plus sample.

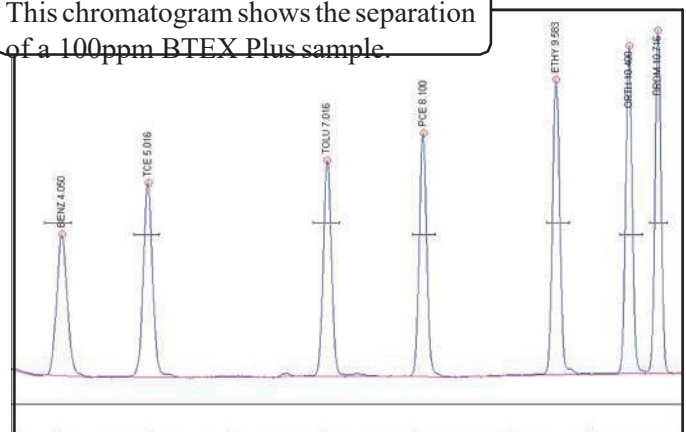

8690-0030

HID detector

# PID - Photo Ionization Detector

- Responds to molecules with carbon double bonds and aromatics
- Sensitive (down to 10ppb) and nondestructive
- Mandated in several EPA Methods
- Extremely long lamp life!

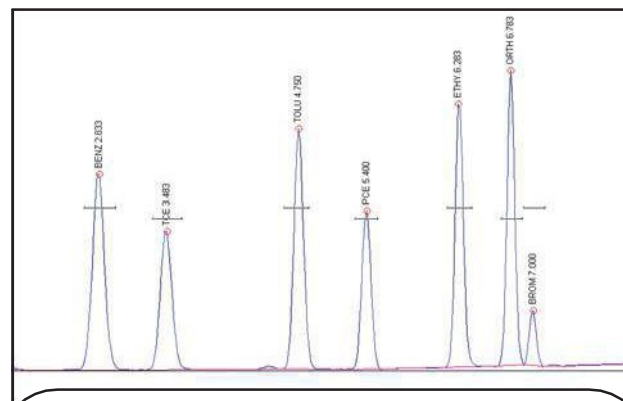

This PID chromatogram shows a separation of a 100ppm BTEX plus sample using a 0.53, 15 meter capillary column and helium carrier gas.

Use of the Photo Ionization Detector is mandated in several EPA methods (8021, TO-14, etc.) because of its sensitivity and selectivity. Detection limits for aromatics are in the low picogram (ppb) range. Because it is nondestructive, the PID is often run in series with other detectors—typically the FID/DELCD combination detector—for multiple chromatograms from a single injection. The PID is also able to run on air carrier, which can be useful in situations where no gas is available, or for stream monitoring applications where no column is used to separate compounds.

Unlike other PID designs, the lamp on the SRI PID can be easily removed, without tools, for periodic cleaning of the lamp window to avoid interference from column bleed build-up. Lamps can last years on the SRI PID because only the lamp window is heated, not the entire body of the lamp.

The SRI design uses the industry standard 10.6eV PID lamp in a spring-loaded mount, which allows the lamp to be removed, cleaned and reinstalled in seconds without tools.

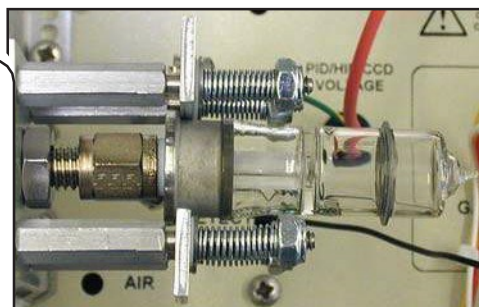

The SRI PID consists of an industry standard UV lamp mounted on a thermostatted, low-volume, flow-through cell. The temperature is adjustable from ambient to 250°C. The 10.6 electron volt UV lamp emits energy at a wavelength of 120 nanometers, which is sufficient to ionize most aromatics (benzene, toluene, xylene, etc.) and many other molecules (H<sub>2</sub>S, hexane, ethanol) whose ionization potential is below 10.6eV. Methanol and water, for instance, have ionization potentials greater than 10.6eV and do not respond on the PID.

8690-0040

PID detector

# NPD - Nitrogen/Phosphorus Detector

- Very Selective to Nitrogen and Phosphorus
- Detects down to 100ppb
- Exceptionally rugged NPD bead
- Similar in design to the FID

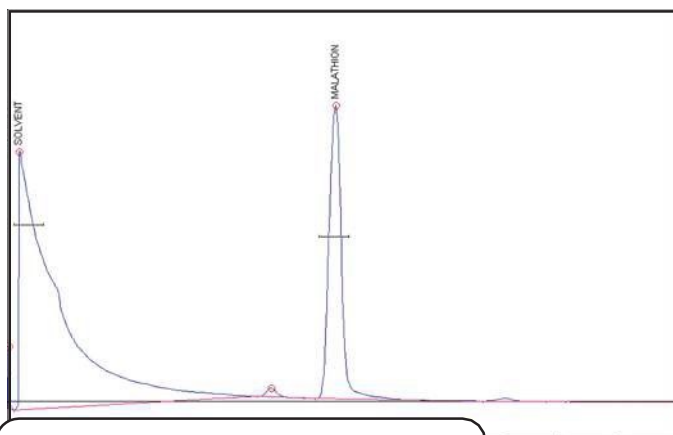

This chromatogram shows the analysis of a 10ppm malathion sample.

The Nitrogen Phosphorus Detector responds to nitrogen-phosphorus compounds about 100,000 times more strongly than normal hydrocarbons. Due to this high degree of selectivity, the NPD is commonly used to detect pesticides, herbicides, and drugs of abuse.

The NPD is similar in design to the FID, except that the hydrogen flow rate is reduced to about 3mL/minute and an electrically heated thermionic bead (NPD bead) is positioned near the jet orifice. Nitrogen or phosphorus containing molecules exiting the column collide with the hot bead and undergo a catalytic surface chemistry reaction. The resulting ions are attracted to a collector electrode, amplified, and output to the data system.



The SRI ceramic NPD bead is exceptionally rugged and long-lasting, offering service from 100 to 1000 hours, depending on operating conditions.

8690-0015	NPD detector
8690-2615	NPD/DELCD combination detector

# TID - Thermionic Ionization Detector

- Highly Selective to Nitro Functional Groups
- Also responds to chlorinated phenols
- Detects down to 1ppb
- Convenient bead design
- Can be run Gasless in the field!

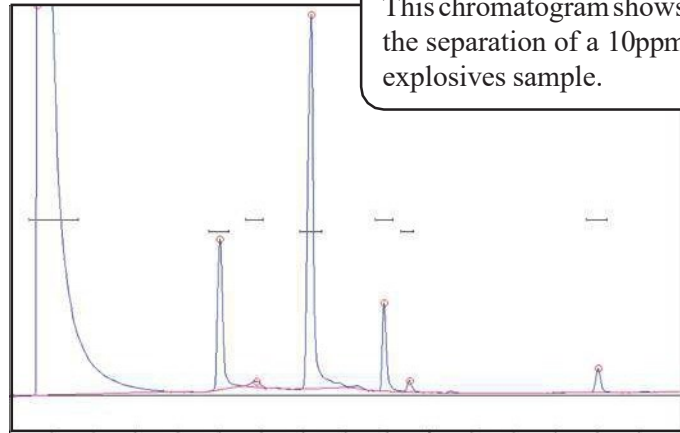

The TID is similar in design to the FID and NPD. The electrically heated thermionic bead (TID bead) is positioned so that the column effluent contacts the hot bead surface. Analyte molecules containing  $\text{NO}_2$  (nitro) functional groups such as TNT (trinitrotoluene) undergo a catalytic surface chemistry reaction. The resulting ions are attracted to a collector electrode, amplified, and output to the data system.

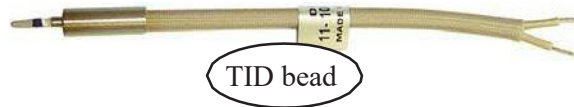

The Thermionic Ionization Detector is extremely selective, having little or no response to most aromatic and aliphatic hydrocarbons. The TID also responds to chlorinated phenols such as pentachlorophenol (PCP) at slightly less sensitivity.

For best sensitivity, the TID requires air for operation. If air is used as the carrier gas, no other detector gases are required. An air makeup gas is provided so that nitrogen or another gas can be used as a carrier. The TID can also be operated in a nitrogen only environment with similar but not identical response characteristics.



**(ETV) program for measuring explosives in soil!**  
**Tested by the EPA's Environmental Technologies Verification**

Download the ETV report and verification statement at [www.epa.gov/etv/verifications/vcenter1-4.html](http://www.epa.gov/etv/verifications/vcenter1-4.html)  
Also, download "On-Site Characterization of Explosive Residues in Soils and on Range Scrap Using GC-TID Analysis" by Alan Hewitt of the US Army Corps of Engineers at [www.srigc.com](http://www.srigc.com)

8690-0017

TID detector

# FPD - Flame Photometric Detector

## FPD, Dual FPD, FPD/FID, FID/Dual FPD



- Bandpass Filters for Sulfur or Phosphorus
- Use the Dual FPD for Simultaneous Sulfur and Phosphorus Detection
- Detects Sulfur Compounds to 200ppb, Phosphorus Compounds down to 10ppb
- Use the FPD/FID or Dual FPD/FID for Simultaneous Hydrocarbon Speciation

The Flame Photometric Detector can detect sulfur compounds, such as  $H_2S$  or  $SO_2$ , down to about 200ppb and phosphorus compounds to 10ppb. While not 100% selective, the FPD is 100,000 times more sensitive to sulfur and phosphorus compounds than hydrocarbons. The phosphorus response is linear, and the sulfur response is exponential (twice the sulfur yields four times the peak area).

The FPD is similar to the FID except that the detector body is light tight and a second flow of hydrogen purges the optical path between the photomultiplier tube (PMT) and the hydrogen rich flame. A bandpass filter (at 393nm for sulfur and 525nm for phosphorus) mounts in front of the PMT, so only the emissions from sulfur or phosphorus are detected while other wavelengths are rejected. The Dual FPD detector is equipped with two PMTs and filters for the simultaneous detection of sulfur and phosphorus.

The two chromatograms shown at right were produced by an SRI GC equipped with an FPD detector. The top chromatogram shows the FPD response to 10ppm  $H_2S$ . The bottom chromatogram shows the FPD response to 10ppm malathion, a pesticide containing both sulfur and phosphorus.

8690-0080	FPD detector
8690-1080	FPD/FID combination detector
8690-0085	Dual FPD with sulfur and phosphorus filters
8690-2085	Dual FPD with sulfur and phosphorus filters, and FID collector electrode

# ECD - Electron Capture Detector

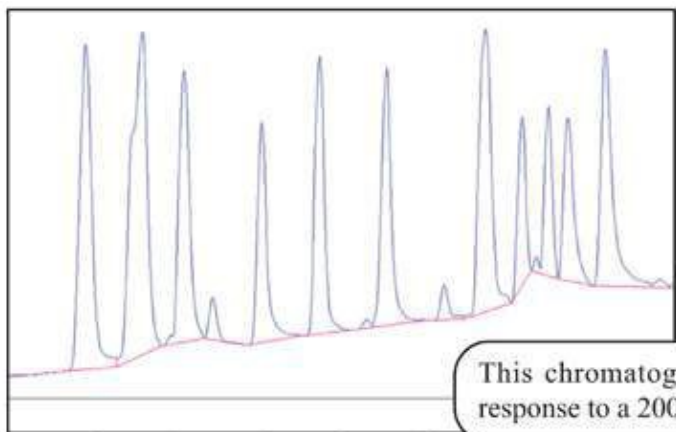

This chromatogram shows the ECD response to a 200ppb pesticide sample.

- Detects Electronegative Compounds
- Offers Extreme Sensitivity - down to 10ppt
- Thermostatted from Ambient to 375°C
- Mandated for Pesticides and PCBs

The SRI Electron Capture Detector can be operated with either nitrogen or argon-5% methane (P5) makeup gas, and nitrogen, P5, or helium carrier (as long as the helium flow is less than 10 milliliters per minute). The ECD may be thermostatted from ambient to 375°C.

The ECD detects electronegative compounds, especially chlorinated, fluorinated, or brominated molecules such as carbon tetrachloride, bromoform, PCBs and pesticides such as DDT. The ECD offers extreme sensitivity (parts per trillion for SF<sub>6</sub>).

The ECD consists of a stainless steel cylinder containing radioactive Nickel-63. The Nickel-63 emits beta particles (electrons) which collide with the carrier gas molecules, ionizing them in the process. This forms a stable cloud of free electrons in the ECD cell. When electro-negative compounds enter the cell, they immediately combine with some of the electrons, temporarily reducing the number remaining in the electron cloud. The detector electronics, which maintain a constant current (of about 1 nanoampere) through the electron cloud, are forced to pulse at a faster rate to compensate for the decreased number of free electrons. The pulse rate is converted to an analog output, which is connected to the data system.



Because it contains only 5 millicuries of Nickel-63, the ECD is covered by a “general license,” which requires a periodic wipe test and the filing of a form with your state’s Department of Health. In most states, no annual fee is required.

8690-0020

ECD detector



# RGD - Reduction Gas Detector

- Detects reducing gases, such as CO to 50 ppb level, and H<sub>2</sub> to 0.5 ppm
- Heated UV detection cell with absorbance
- User packable reaction tubes (requires mercuric oxid, not included)

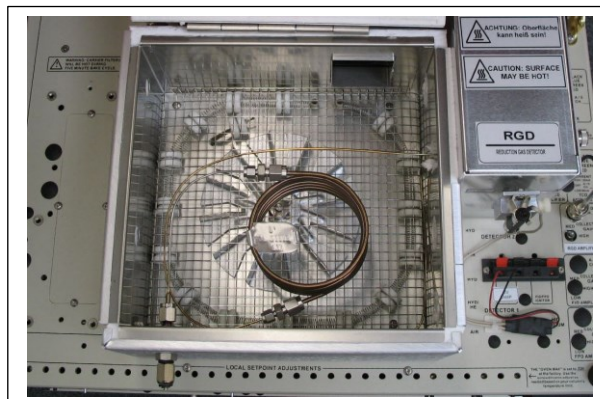

The SRI reduction gas detector is sensitive to volatile reducing compounds down to the ppb level, and is often used to detect atmospheric carbon monoxide and hydrogen.

When compared to the FID detector, the RGD is ten times more sensitive to unsaturated hydrocarbons, and virtually unresponsive to saturated hydrocarbons. This combination of sensitivity and selectivity allows the analysis of atmospheric pollutants such as ethylene, benzene, carbonyl sulfide, phosphine, and methanol.

Our RGD uses a mercuric oxide reaction tube and a mercury lamp in a heated UV detector cell. When a reducing gas elutes from the column into the hot reaction tube, it reacts with the mercuric oxide to form mercury vapor. As it flows through the detector cell, the gaseous mercury absorbs the UV light from the mercury lamp inside the cell. The change in transmittance is converted by the data system into an absorbance output, which is proportional to the amount of reducing gas. A carbon filter at the UV detector cell outlet traps the condensed mercury vapor for safe disposal.

High concentrations of chlorinated and aromatic compounds can easily contaminate the mercuric oxide bed, resulting in the need for replacement. Reaction tubes are easily replaceable, and blank reaction tubes can be economically packed by the user.



# GC Injectors

SRI offers a wide variety of GC injectors and injection systems. Up to five injectors may be mounted simultaneously on the Model 8610C or 8610D. The Model 310 will accommodate a single On-column, Heated Flash Vaporization, Heated Split/Splitless, or PTV injector. Injector types are selected by the user depending on the particular measurement application, detection limit, and regulatory requirements. The On-Column Injector is standard equipment on every 8610, 410 and 310 GC. Heated Flash Vaporization, Heated Split/Splitless, and PTV Injectors are all upgrades to the On-Column Injector. All injectors must be installed at the SRI factory.



1. On-Column Injector
2. On-Column PTV Injector
3. Heated Flash Vaporization Injector
4. Heated Split/Splitless Injector
5. PTV - Programmable Temperature Vaporization Injector
6. 10-Port Gas Sampling Valves & 22-port Selector Valves
7. Sample Preconcentration and Enrichment Options:
  - Heated Adsorbent Traps
  - DGA Permeation Loop Accessory
8. Heated Static Headspace Injector
9. Method TO-14 Air Concentrator (1 Trap or 2)
10. Thermal Desorber
11. Method 5030/5035 Compliant Purge & Trap
12. 10-Sample 5030 Purge & Trap Autosampler
13. 110 and 120 Vial Autosamplers
14. 28, 40 and 50 Vial Headspace Autosampler

## SAMPLE TYPES AND APPROPRIATE INJECTORS

SAMPLE TYPES AND APPROPRIATE INJECTORS	
<b>LIQUIDS</b>	<ul style="list-style-type: none"> <li>• On-column, Heated Split/Splitless, Heated Flash Vaporization, PTV, Heated Static Headspace, Purge &amp; Trap, Liquid Injection Valve, Liquid Autosamplers, or Headspace Autosampler</li> </ul>
<b>SOLIDS</b>	<ul style="list-style-type: none"> <li>• Thermal Desorber, Heated Static Headspace, PTV, or Headspace Autosampler</li> </ul>
<b>GASES</b>	<ul style="list-style-type: none"> <li>• On-column, Gas Sampling Valve, Method TO-14 Air Concentrator, or Heated Static Headspace</li> </ul>
<b>SPME FIBERS</b>	<ul style="list-style-type: none"> <li>• Heated Flash Vaporization with Low Volume SPME Liner, or Heated Split/Splitless</li> </ul>

# On-Column Injector

- Simple and Reproducible
- For Liquids and Gases with Low AND High Boiling Analytes
- For 0.53mm Capillary and 1/8" Packed Columns
- No Boiling Point Discrimination
- Low thermal mass

The On-Column Injector is supplied as standard equipment with the 8610, 410 and 310 GC mainframes.

For most applications, where a wide-bore 0.53mm capillary or 1/8" packed column is used, the On-column Injector will give the BEST results. In most cases the On-Column Injector is simpler and less expensive than heated injectors.



The On-Column Injector is perfect for liquids and gases with high and low boiling analytes. Even very high temperature analyses are easily performed using simple, reproducible on-column injection.

The On-Column Injector's low mass and small size ensure that the injector body temperature closely follows the column oven temperature.



The injector's low thermal mass and small size ensure that the syringe needle deposits the liquid sample well inside the column oven, so that as the column temperature increases, even high boiling point samples are completely vaporized. The On-column technique of sample introduction puts the sample into the bore of the column itself, which is often more inert than a glass injection liner. Unlike split/splitless injection, on-column injection puts the entire sample volume into the column without the possibility of boiling point discrimination or other uncertainties, and the gradual volatilization of the sample starting from a liquid droplet yields sharper peaks than flash vaporization followed by recondensation.

The On-column Injector is supplied with carrier gas from the included Electronic Pressure Controller (EPC), and the carrier gas is conveniently filtered with an internally mounted Molecular Sieve filter which can be baked out simply by flipping a switch on the GC's front control panel. A second EPC is available for operating a column connected to a gas sampling valve (or for backflushing) without the injector fitting. Also available is a second injector fitting connected to the first EPC for applications where two columns are used in parallel, sharing the same carrier gas pressure.

- |           |   |
|-----------|---|
| 8690-0023 | On-Column Injector for 0.53mm capillary and 1/8" packed columns. Includes EPC carrier gas controller and molecular sieve filter |
| 8690-2022 | Second carrier gas EPC without injector port fitting  |
| 8690-2023 | Second injector port fitting without EPC  |

# On-Column PTV Injector

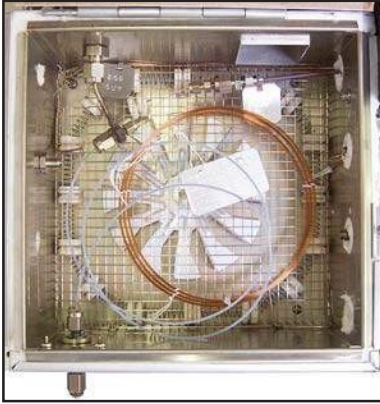

- Inject Larger Volumes onto Narrow Bore Columns
- Concentrate Sample and Focus Peaks
- Simpler than Split/Splitless Injectors
- Less Bulky than Conventional PTVs
- Great for Semivolatile Samples

The On-Column PTV is a resistively heated precolumn, which is connected to your narrow bore column with a special, electrically insulated split “T” inside the GC column oven. The 5 micron nonpolar phase in the OCPTV precolumn has a high capacity to absorb high boiling compounds, and is stable at high temperatures. Like in-tube SPME, the precolumn discriminates in favor of high boiling semivolatile analytes, concentrating them in the phase. Like the Split/Splitless injector, the OCPTV has a split vent and needle valve for venting solvent while concentrating sample. Unlike a normal Heated Split/Splitless injector, the OCPTV vents the solvent without expanding it to a gas. Therefore, the OCPTV is capable of larger liquid injections than a regular heated split/splitless injector.

The GC operator injects sample via syringe through the on-column injection port with the split vent open to vent the solvent. After injection and solvent venting, the precolumn heats up while the carrier gas flows through it to sweep focused analytes from the precolumn to the analytical column. At this point, the precolumn is hotter than the column oven. The temperature difference between the hotter precolumn and cooler analytical column causes the analytes to focus on the analytical column, resulting in sharp peaks on the chromatogram.

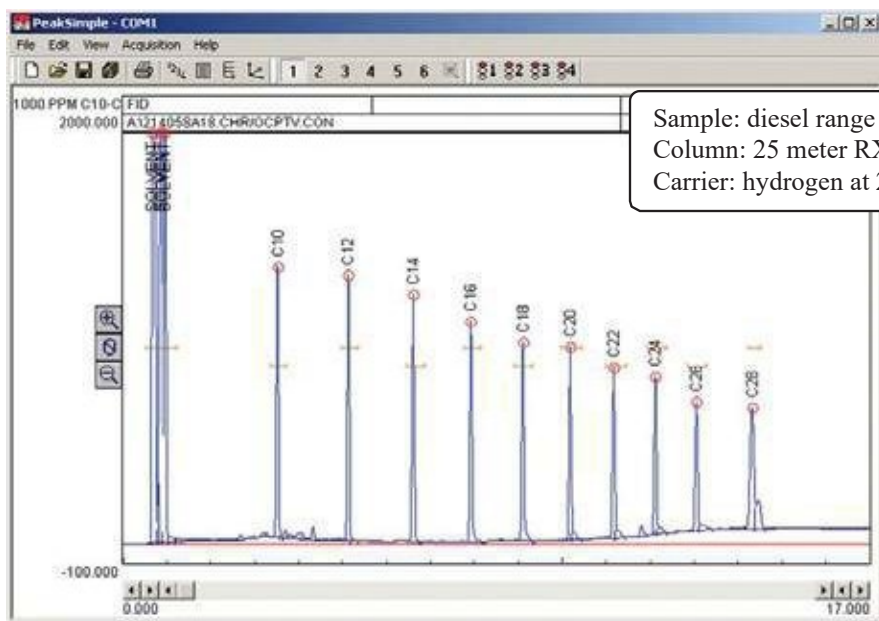

This chromatogram was generated by an SRI GC equipped with an OCPTV injector and an FID detector. A 25 meter narrow bore capillary column was used to separate 100ppm diesel range organics (DRO).

8690-0037

On-Column PTV Injector for GC

# Heated Flash Vaporization Injector

- Desorption of SPME Fibers
- Extremely Dirty Samples
- Adjustable from ambient to 300°C
- Includes On-Column Mode

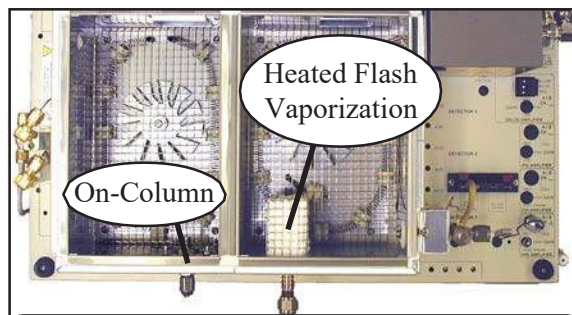

This 8610D GC has a standard On-Column Injector on the first oven, and an optional Heated Flash Vaporization Injector on the second oven.

The SRI Heated Flash Vaporization Injector is useful for applications which require flash vaporization of the sample prior to the column, such as desorption of SPME fibers or injection of extremely dirty samples where the nonvolatile residue must be trapped in the injection liner.

The injector's heater block can be thermostatted up to 300°C, and includes as standard equipment two injector liners: an inert Silcosleeve™ liner, and an unbreakable stainless steel liner, which also allows for on-column mode.

The Heated Flash Vaporization Injector option is an upgrade to an existing On-column Injector. Two heated injectors may be installed on the Model 8610C GC, but only one on the smaller Model 310. Where no need for a heated injector exists, SRI recommends using the standard On-column Injector.

## Heated Injection vs. On-column Injection: PROS and CONS

In the early days of GC, the column oven insulation was typically several inches thick. It was not then possible to insert a syringe through the oven wall to deposit the sample on the column and be assured that the sample would completely vaporize unless the injector was heated. On today's SRI GC, the oven wall insulation is much thinner. This allows the syringe needle to penetrate well inside the column oven, thus depositing the sample into the bore of the column itself. As the temperature is programmed up, the sample is completely vaporized. Even high boiling analytes such as C<sub>44</sub> hydrocarbons chromatograph well using on-column injection, since the area of the column where the sample is deposited follows the column temperature and ultimately heats to a point where the C<sub>44</sub> begins to migrate down the column. There is no need to employ a heated injector unless the sample needs to be split, or if the sample needs to be desorbed from a SPME fiber. In fact, the heated injector has some distinct disadvantages. The internal surfaces of the injector liner are more chemically active than the very inert interior of the column, so undesired adsorption and tailing can result when the sample is violently expanded in the hot interior of the heated injector. Also, the heated injector transmits some heat into the column oven because of its close proximity, making it harder for the oven to cool down close to ambient temperature.

8690-0025	Heated Flash Vaporization Injector upgrade
8670-0072	Narrow bore SPME injector sleeve

# Heated Split/Splitless Injector

- Split, Splitless, or On-Column Modes
- Narrow or Wide Bore Capillary Columns
- Adjustable from Ambient to 300°C
- Adjustable Split Flow

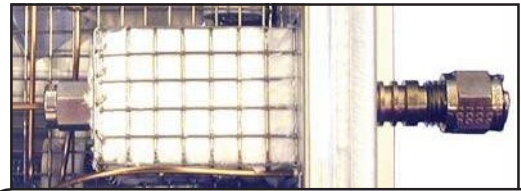

The Split/Splitless Injector is insulated to help maintain its temperature independently of the column oven temperature.



The split flow is adjustable by a precision needle valve on the front of the GC valve oven. The GC pictured here is also equipped with a gas sampling valve, with the sample IN and OUT also on the front of the valve oven.

The Heated Split/Splitless Injector permits the use of narrow-bore capillary columns (0.32mm I.D. and smaller) in split or splitless modes. Capillary columns with 0.53mm I.D. and 1/8" packed columns can be used in split, splitless, or on-column modes. The injector temperature is adjustable from ambient to 300°C. The split flow is adjustable by means of a precision needle valve, and can be turned ON/OFF with a timed Event from the PeakSimple data system. One Silcosleeve liner and one unbreakable stainless steel liner are supplied as standard equipment with the injector.



Stainless steel and Silcosleeve liners with megabore column adapter

The Split/Splitless Injector option is an upgrade to an existing On-column Injector, which is standard equipment on every SRI GC. When it is desired to add the Split/Splitless Injector as the second injector, an On-column Injector must be ordered as well (part number 8690-0023, page 54).

8690-0034

Heated Split/Splitless Injector upgrade

# PTV - Programmable Temperature Vaporization Injector

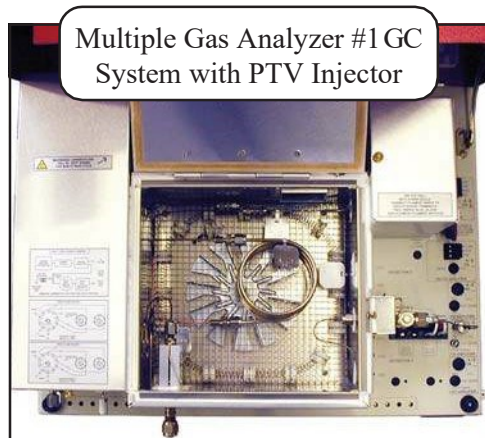

- Ballistic Heating
- Ability to Stop carrier gas
- Large Volume Injections—to 1.0mL+
- Achieve Low Detection Limits without pre-concentration
- Split/Splitless & On-Column Modes
- Thermal Desorption Applications
- PeakSimple Control

The Programmable Temperature Vaporization (PTV) option adds ballistic heating capability to the Heated Split/Splitless Injector to accommodate large volume injections or thermal desorption applications. In the PTV mode, the insulation is removed from the Split/Splitless Injector, so that the oven fan can cool the PTV Injector down between analyses.

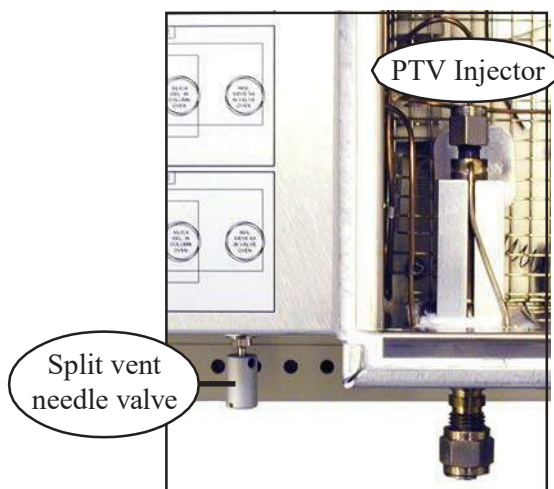

A small amount of adsorbent material, like Tenax, is packed inside the PTV injector sleeve. The initial column oven temperature, which maintains the injector cool-down temperature, should be set slightly higher than the boiling point of the solvent. As a large volume of sample is injected, the solvent vaporizes and passes through the adsorbent material and out the split vent. The split vent and carrier gas are under PeakSimple control. The carrier gas can be turned OFF during the PTV ballistic heating, in order to preheat the adsorbed analytes prior to desorbing onto the column.

The Silcosleeve™ liner can be packed with adsorbents like Tenax, loaded with sample offline, then inserted into the PTV for desorption.

8690-7034

PTV & Split/Splitless Injector upgrade

# 10-Port Gas Sampling Valves and 22-Port Selector Valves

- Heated, Thermostatted Valve Oven
- Standard & Custom Plumbing Configurations
- Electronically Actuated with PeakSimple Control or Manually Actuated
- 1, 2, or 3 Valve Capability

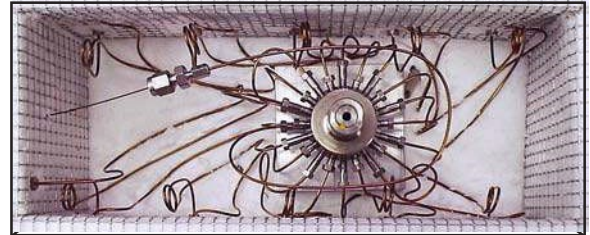

22-port stream selector valve on our 10 position Method 5030 Purge & Trap Autosampler

SRI uses 10-port gas sampling valves because they provide more analytical flexibility for the same cost as 4 or 6 port valves. 10-port gas sampling valves can easily be plumbed to replicate the function of the simpler valves, while offering many other possible configurations. SRI offers standard plumbing configurations, including: Inject Only, Inject and Backflush, Precolumn Backflush to Vent, Column Sequence Reversal, Alternate Loop Inject, and Dual Loop-Dual Column. Many more plumbing configurations are possible, especially when multiple valves are plumbed together.

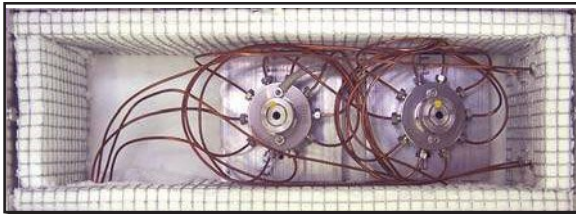

Dual 10-port gas sampling valves in the heated valve oven of a customized dual TO-14 injector

The optional valve oven, mounted on the 8610C GC, can accommodate two electrically operated plus one manually operated valve, and can be adjusted from ambient to 175°C (up to 300°C for the manual valve). Because the valve oven is immediately next to the column oven, tubing runs are short with no cold spots, which results in sharper peaks.

Each valve includes 1/8" stainless steel bulkhead fittings on the front of the optional valve oven for sample in/out connections. A single heated (375°C max) fast-cooling adsorbent trap plumbed as the loop of the gas sampling valve is also available for applications where sample concentration is desired. The trap cools to a user-controlled setpoint, not just to ambient temperature, so the adsorbent characteristics (water rejection, etc.) can be manipulated.

8690-0063	10-Port Manually Actuated valve, plumbed & tested
8690-0065	10-Port Electrically Actuated valve, plumbed & tested
8690-0077	Automated 22-port, 10-Stream Selection valve, plumbed & tested
8690-0088	Heated, thermostatted valve oven mounted on an 8610C GC



# 10-Port Gas Sampling Valve Plumbing Option Examples

The valve plumbing configuration shown at right is the standard 6-port configuration. The sample loop connected between ports 3 and 10 is inserted into the carrier gas stream

when the valve is rotated to the INJECT position.

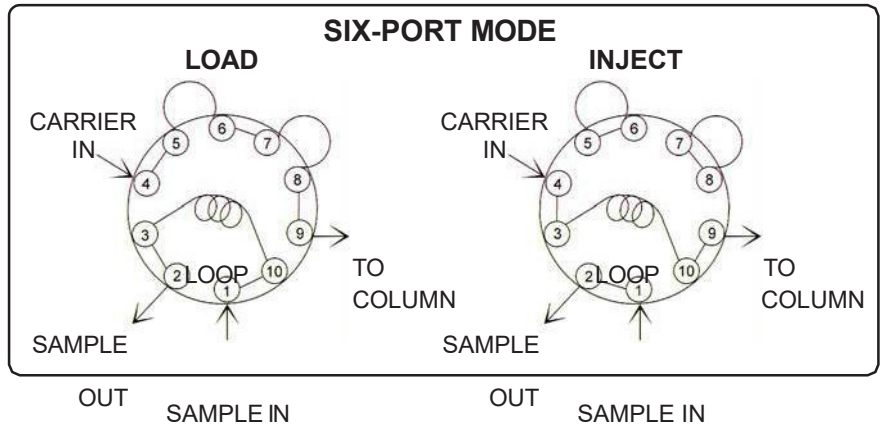

The same 10-port valve can also be configured to backflush the column when the valve is rotated. Backflushing can often shorten the analysis by eliminating the need to program the column temperature up to elute high boiling analytes.

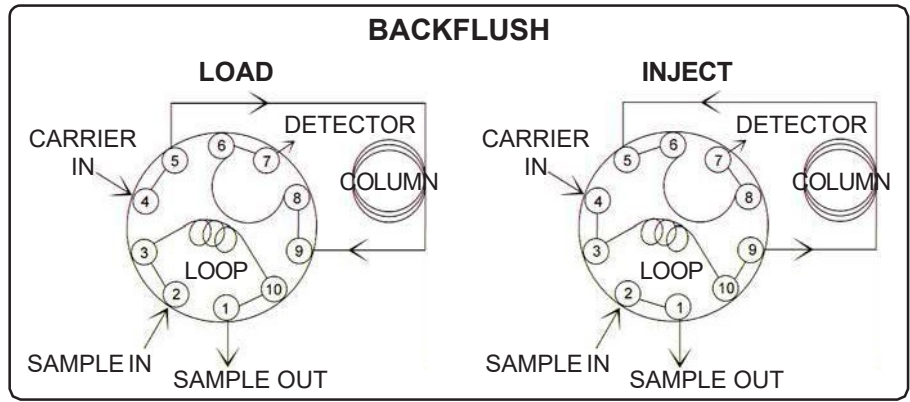

A single 10-port valve can be plumbed to inject the same sample onto two separate columns using two separate loops. This is especially useful where two different carrier gas types are used, or where the detectors employed have very different sensitivities and need different sample sizes injected.

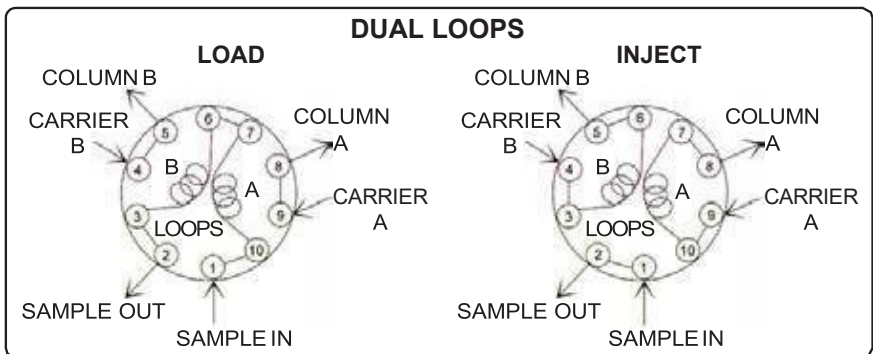

valve configuration shown at right is our Multiple Gas Analyzer #1 (MG#1) valve. In the LOAD position, the sample loop is filled with new sample gas, and the Silica Gel column is downstream of the MoleSieve column. In the INJECT position (shown), the contents of the loop are flushed into the Silica Gel column, which is now upstream. The lightest analytes blow through onto the MoleSieve for separation. The valve is then rotated back to the LOAD position, just prior to the elution of ethane for the separation of C<sub>2</sub>-C<sub>6</sub>.

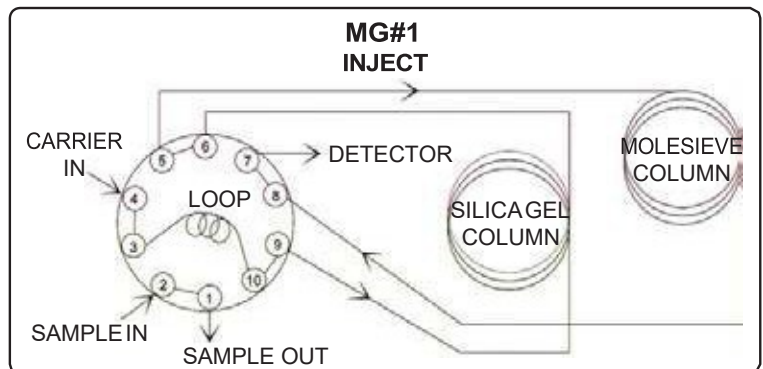

# Sample Preconcentration and Enrichment Options

SRI offers a variety of trapping options for preconcentrating or enriching samples for GC analysis.

- **Traditional Heated Adsorbent Trap** for preconcentrating molecules between  $C_3$  and  $C_{15}$
- **Permeation Trap** for gases dissolved in liquid samples`
- **Enrichment Coil** for thermal modulation of gas streams

In terms of flow, the preconcentrator is always upstream of the GC column oven. Trap and valve ovens are mounted on the left-hand side of the GC.

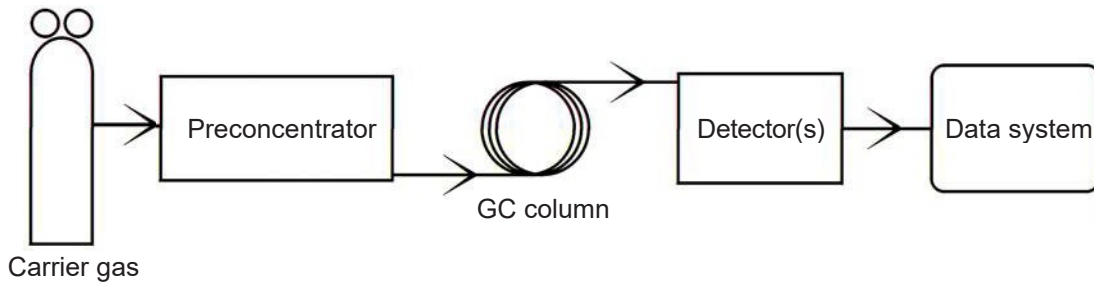

Most of these options employ the versatile 10-port gas sampling valve described on the previous pages. Each valve in turn requires a heated valve oven. The only exception featured here is the Enrichment Coil option, designed for use on the Model 110 detector chassis or in the GC column oven.



Permeation trap with  
DGA accessory



Dual TO-14 Concentrator  
(four traps, two valves)

# Heated Adsorbent Traps

- Dual setpoints for adsorption & desorption temperatures
- Preconcentrates molecules between C<sub>3</sub> and C<sub>15</sub>
- Single (1/8") or Dual (1/4") Independently Heated Traps
- Requires a 10-port Valve & Valve oven
- Adsorbent packing of your choice
- PeakSimple Control

## ADSORBENTS

Carbosieve II MoleSieve 13X  
 Carbopack B Silica Gel  
 HayeSep-D Tenax-GR

Heated adsorbent traps are a simple and economical way to preconcentrate samples for the GC. A heated trap consists of a stainless steel tube packed with adsorbent. While sample is drawn through the tube, analytes of interest are trapped on the adsorbent bed. Then, the trap is heated and the valve rotated to desorb the analytes into the carrier gas stream, which deposits them in the analytical column for separation prior to reaching the detector.

Each SRI trap is plumbed as a sample loop of a 10-port gas sampling valve. A valve and heated valve oven must be ordered along with a heated trap. SRI heated traps are installed in the ducts of the valve oven on the left-hand side of an SRI 8610 GC.



Top view of an SRI heated trap



Choose one or two independently heated traps packed with your choice of adsorbent. Rather than using multiple adsorbents with different affinities and desorption temperatures in one trap, SRI uses a unique dual trap system for simultaneous trapping and desorption of dissimilar analytes. Dual heated traps are an integral part of the SRI Purge and Trap and the TO-14 AirConcentrator. For most applications, dual heated traps still require just one 10-port gas sampling valve.

- |           |  |
|-----------|--|
| 8690-0084 | Heated/fast cooling adsorbent trap and plumbing for existing gas sampling valve 1/8" |
| 8690-1084 | Heated/fast cooling adsorbent trap and plumbing for existing gas sampling valve 1/4" |
| 8690-0065 | 10-Port electrically actuated valve, plumbed & tested                                |
| 8690-0088 | Thermostatted valve oven mounted on an 8610C GC                                      |

# DGA Permeation Loop Accessory

- For Extracting and Preconcentrating Dissolved Gases in liquid samples
- Built-in Standards Preparation Module—Make Your Own Standards
- Requires a Valve Oven & one or two 10-port Valves

The Permeation Loop consists of permeation membrane tubing encapsulated in a trap-heated glass tube. When sample liquid is pumped through the permeation tubing, the dissolved gases therein selectively permeate through the heated membrane into the surrounding extraction chamber, which is plumbed as the loop of a 10-port gas sampling valve.

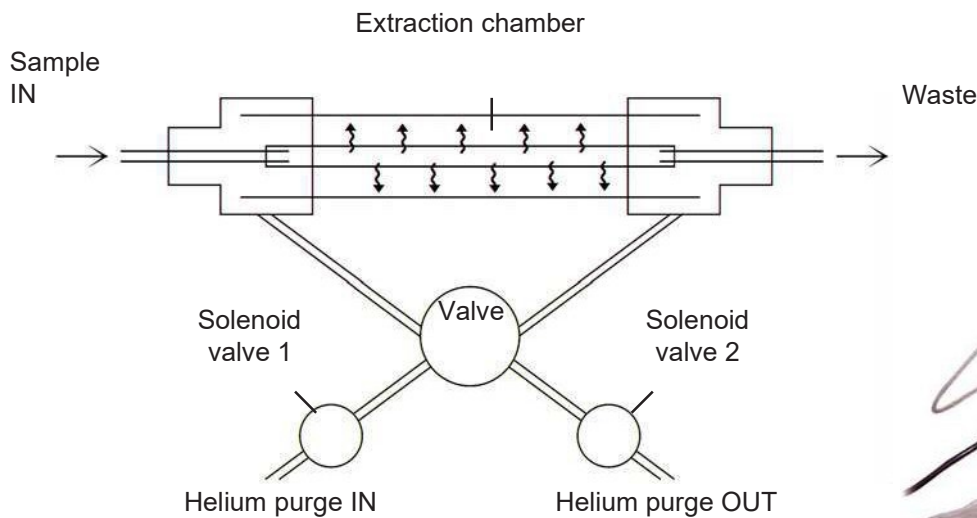

## Top view of the DGA-TOGA Permeation Trap Accessory

Heated valve oven with 10-port valve inside

Permeation Trap

Standards preparation sparge head

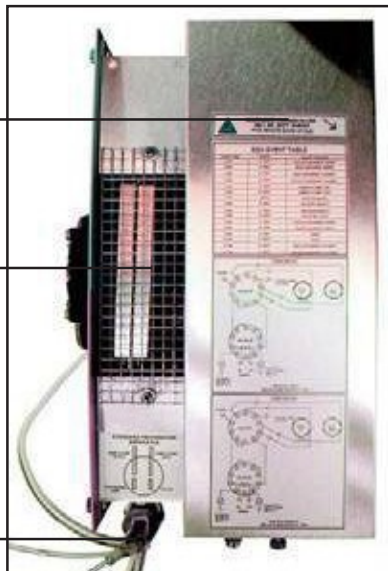

The Permeation Loop Accessory includes the permeation trap, two peristaltic pumps, two solenoid valves, and a standards preparation sparge head. By reconnecting a few tubing lines, the DGA-TOGA Permeation Loop Accessory can be configured to prepare dissolved gas standards. A Tedlar bag, or other container, filled with gas standard is connected to the standard pump. The standards preparation vessel is filled with sample liquid, such as water. The standard pump bubbles gas standard into the standards preparation vessel, equilibrating the liquid over time to a known concentration.

- |           |   |
|-----------|---|
| 8690-0087 | DGA Permeation Trap accessory                         |
| 8690-0065 | 10-Port electrically actuated valve, plumbed & tested |
| 8690-0088 | Thermostatted valve oven mounted on an 8610C GC       |

## Method TO-14 Air Concentrator (1 Trap or 2)

- Sample from Source, Tedlar Bags, Canisters, or Ambient Air
- Vacuum Pump and Data System controlled Interface
- Independently Heated Dual Trap Design (optional)
- 10-port Electrically Actuated Valve
- PeakSimple Control

The SRI Method TO-14 Air Concentrator is equipped with a vacuum pump and interface, a 10-port gas sampling valve, and one or two independently heated adsorbent traps. The included external vacuum pump may be attached to the downstream side of the traps to load a gas sample automatically, under control of the PeakSimple data system.

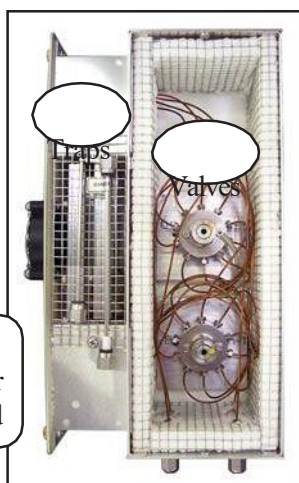
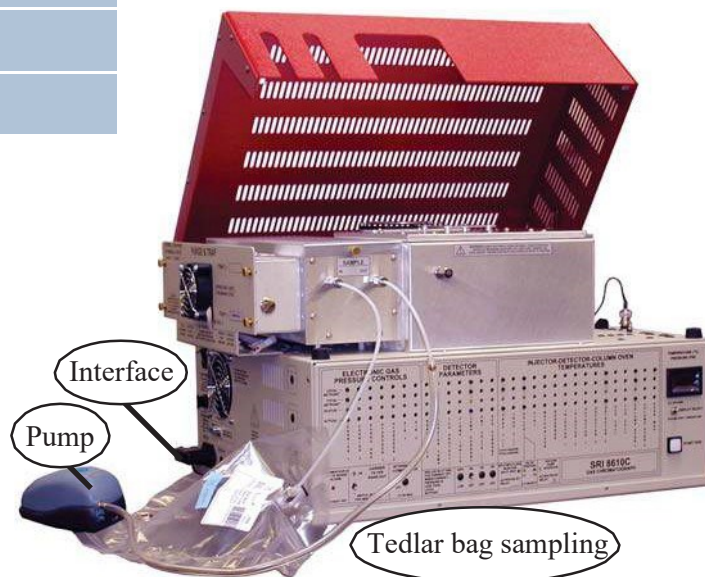

Shown here is a dual TO-14 Air Concentrator with four traps and two gas sampling valves.

The gas sample may be contained in Tedlar bags or canisters, or may be sampled directly from the source. The vacuum pump is operated for several minutes or more to pass 100-200mL/minute of gas through the traps, where the organics are retained. Several liters or more may be concentrated, depending on the detection limit required. Once the analytes are trapped, they are desorbed and directed to the column for separation.

The TO-14 Air Concentrator comes with single or dual traps. The single trap option is good for most analyses. If vinyl chloride is a target analyte, order the dual trap option. Please see the Purge & Trap pages for an explanation of the benefits of our unique dual trap design.

8690-1051

Method TO-14 Air Concentrator with 1 trap

8690-1055

Method TO-14 Air Concentrator with 2 traps

# Automated Calibration System (ACS)

## For the SRI TO-14 Air Monitoring GC

The SRI Automatic Calibration System (ACS) allows for automatic, unattended recalibration when using an SRI GC equipped with the TO-14 Air Concentrator for ambient air analysis.

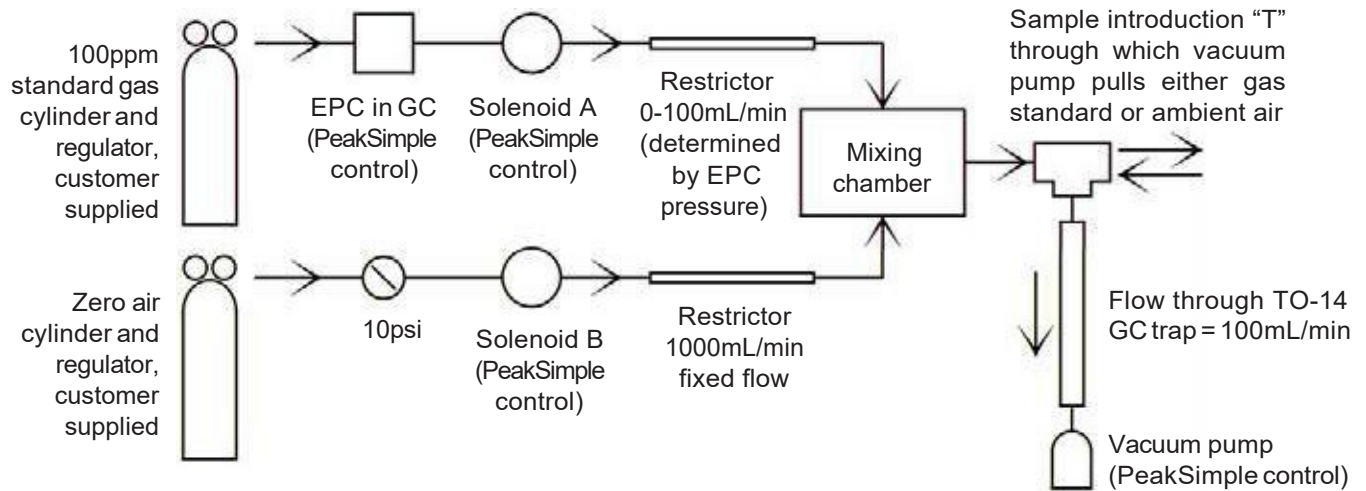

Under control of the PeakSimple software included with the GC, the ACS can make dilutions of the customer-supplied standard gas and Zero Air at ratios of 10,000 to 1. For example, if the standard EPC on the TO-14 GC is set to 50psi, a 100ppm standard gas flows through the restrictor at a rate of 100 milliliters per minute; the Zero Air flows at a rate of 1,000 milliliters per minute. This produces a 10ppm diluted gas, which is sampled into the TO-14 Air Concentrator by the vacuum pump (supplied with the TO-14 Air Concentrator).

By manipulating both the EPC pressure and time, the 100ppm standard can be diluted over a 10,000 to 1 concentration. For example, let's say you've decided to use 300 seconds as the length of time the vacuum pump is sampling the standard gas. If the standard EPC pressure is reduced to 10psi, the standard gas flow rate is reduced to 10 milliliters per minute, and the resulting diluted concentration is 1ppm. If solenoid A is open for 30 seconds (10% of the total 300 second time period during which the vacuum pump is pulling sample through the TO-14 trap), the resulting time-averaged concentration is 100ppb. Because PeakSimple controls the dilution ratio, a multi-point calibration curve can be automatically constructed as part of the Autosampler Queue feature. The Autosampler Queue permits PeakSimple to periodically recalibrate without operator intervention.

# Thermal Desorber



- Volatile & Semivolatile compounds in Solid Matrices
- Mounts in the Valve Oven on the 8610C GC
- High Temperature & High Sensitivity
- Manually Actuated 10-port Valve
- No solvent extraction required
- Simple to Use

The SRI Thermal Desorber accessory permits volatile and semivolatile compounds in soil, or other solid matrices, to be injected and analyzed with little or no sample preparation, and with very high sensitivity.

With the Thermal Desorber, no solvent extraction is required. This is a major convenience for field operations, and helps save on costs. Little operator skill is needed, and 4-10 analyses can be run per hour, depending on specific requirements.

Up to one gram of soil is loaded into a reusable glass tube, and secured in place with plugs of glass wool. The tube is then inserted into the hot (275 °C) thermal desorber fitting, which is mounted in the heated valve oven compartment of the 8610C GC.

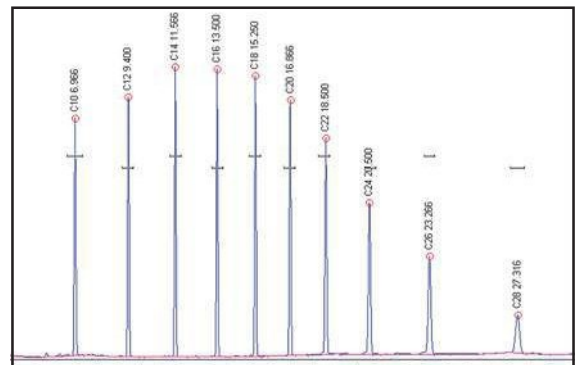

This chromatogram is from a GC with a Thermal Desorber and an FID detector. Synthetic diesel range samples like this are used to verify complete desorption. Sample: 2000ng synthetic diesel range organics desorbed from soil.

Because of the large sample size—up to 1 gram, an analyte present in the soil at 1ppm desorbs 1000 nanograms onto the GC column. This results in detection limits in the ppb range for most compounds. Sandy soil can typically be desorbed with no sample preparation at all. Clay soil is first mixed with sodium sulfate granules to break the clay into a fine powder coating the granules, then the clay and sodium sulfate mix is desorbed.

# Thermal Desorber

Soil samples can typically contain 20-50% water. FID or FID/DELCD detectors are commonly used with the Thermal Desorber, because the SRI FID automatically relights the flame after the large water peak. The Thermal Desorber + FID/DELCD configuration is perfect for detecting PCBs, pesticides, PAHs, JP-4, kerosene, and diesel in soil. Due to the extreme selectivity of the DELCD, PCBs can be discriminated even in the presence of massive hydrocarbon contamination.

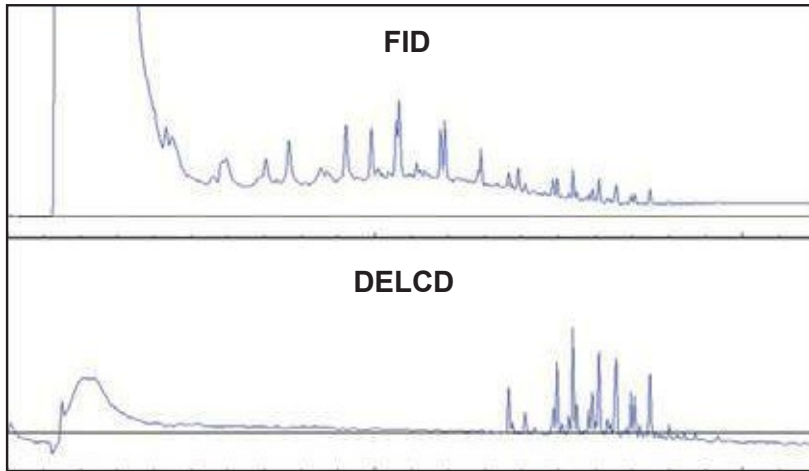

The top two chromatograms show the analysis of PCB 1254 standard in diesel oil with our PCB GC System, which is equipped with a Thermal Desorber and FID/DELCD detectors in combination. The FID shows the diesel hydrocarbons and the PCBs, but the PCB peaks are obscured by the diesel peaks. In contrast, the DELCD shows the PCBs only, revealing what was essentially hidden in the FID chromatogram.

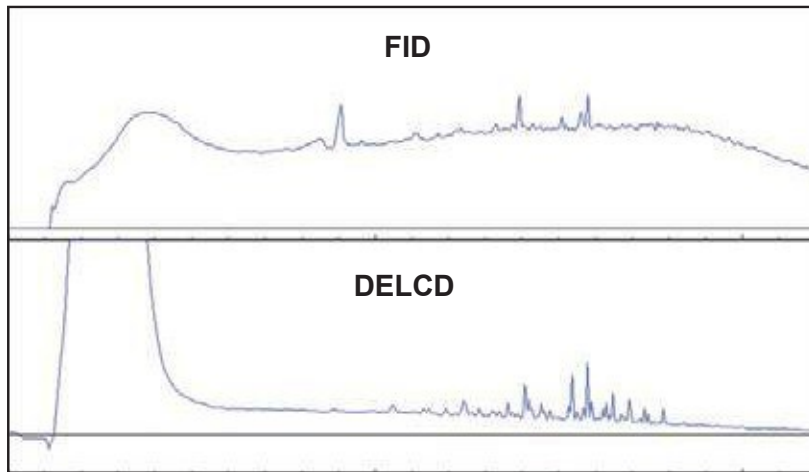

The bottom set of chromatograms show the analysis of a real-world standard: 0.3 grams of soil from a contaminated site. This real-world standard is NIST certified to contain 1.34ppm PCBs. The FID shows a large hydrocarbon matrix which is precombusted in the FID flame prior to reaching the DELCD, which shows a clean PCB 1254 chromatogram. Precombustion of the sample by the FID protects the DELCD from hydrocarbon contamination.

- |                  |  |
|------------------|--|
| <b>8690-1088</b> | <b>Thermal Desorber on 8610C GC</b><br>Includes 10 reusable glass desorber tubes |
| <b>8690-1087</b> | <b>10-pack reusable ground glass desorber tubes</b>                              |



## For the SRI TO-14 Air Monitoring GC

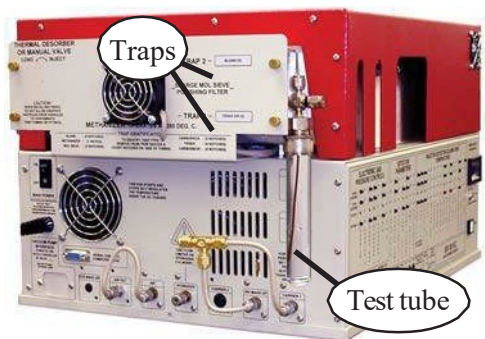

- Built into the GC for lower dead volume and better peak shape—no transfer line!
- Two Independently heated Adsorbent Traps
- EPA Methods Compliant
- PeakSimple Control

The Method 5030 Compliant Purge & Trap uses disposable test tubes at ambient temperature.

Built-in to the Model 8610C GC, the SRI Method 5030/5035 Compliant Purge & Trap concentrates the volatile organic compounds (VOCs) in a gas, water, or soil sample onto two adsorbent traps, from which they are automatically desorbed onto the GC column. The Method 5030/5035 Compliant Purge & Trap is equipped with interchangeable purge heads. The 5035 purge head is a thermostatted (typically 40°C) sleeve which accepts standard 40mL VOA vials. The entire sleeve is mechanically agitated while purging to comply with the requirements of EPA Method 5035. The 5030 purge head uses low-cost, disposable 16mm test tubes which are purged at ambient temperature. For higher level soil samples or soil/methanol extractions, the test tube is more convenient and less expensive than VOA vials.



The Method 5030/5035 Compliant Purge & Trap has interchangeable purge heads, and a syringe port for adding internal standard or water. The 5035 purge head is heated and mechanically agitated under PeakSimple data system control.



Operation of the Purge & Trap is completely automated by the PeakSimple data system that is built into the GC. Run parameters such as purge time, desorb preheat, bake-out, vial temperature, and mechanical agitation are adjusted in a PeakSimple Event table.

The SRI Purge & Trap is unique because it is equipped with two traps rather than one, and each trap can be heated independently at the adsorption temperature (typically 35-70°C), the desorption temperature (200°C), and the bake-out temperature (250°C). For most VOC applications, the first trap is Tenax-GR, and the second trap is Carbon Molecular Sieve. By setting the adsorption temperature of the Carbon MoleSieve to 50-60°C and the Tenax-GR to 35°C, water retention is dramatically reduced. By staggering desorption times, early eluting peaks from the hot Carbon MoleSieve trap are refocused on the temporarily cold Tenax-GR trap, resulting in much sharper peaks than otherwise possible (see the chromatograms on the following page).

# Purge & Trap

By comparing the relative response, the three detectors make peak identification and confirmation easy. The FID responds to all hydrocarbons, the PID responds to some hydrocarbons and all aromatics, and the DELCD responds to halogens only.

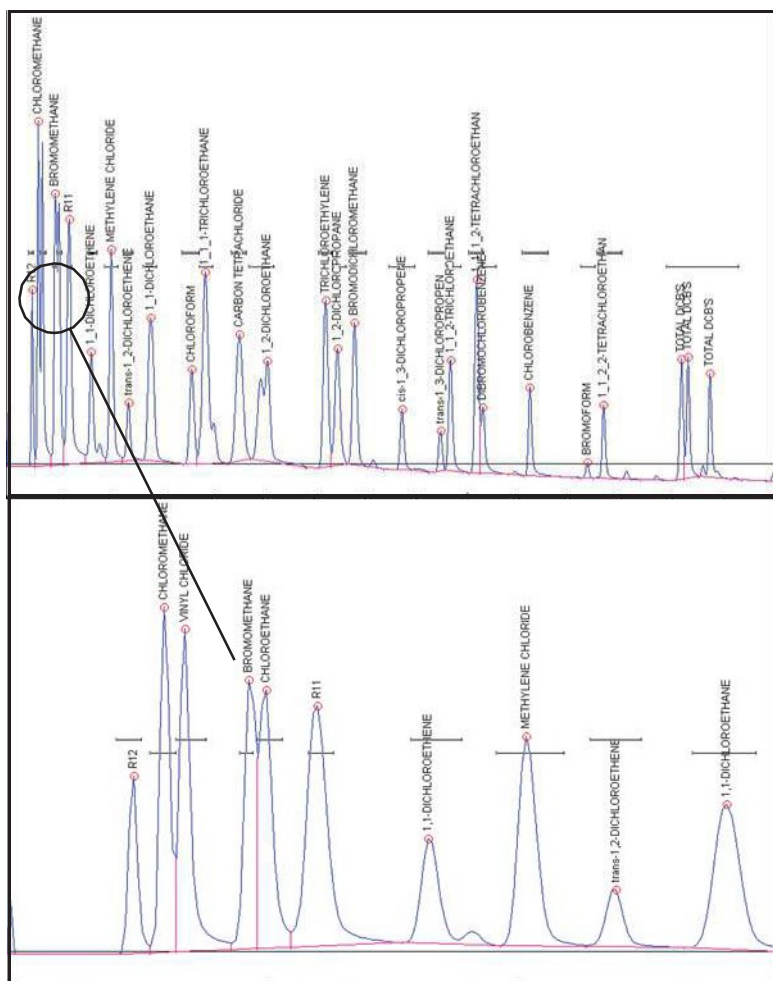
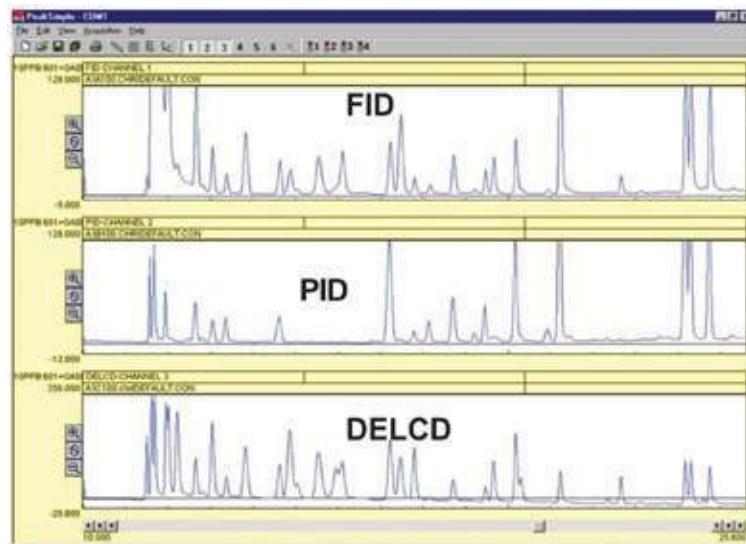

The DELCD chromatogram is shown at left in more detail, and with the peaks labeled for identification. The DELCD is completely selective for compounds containing chlorine and/or bromine. Other analytes do not respond at all, even at very high levels. The DELCD actually operates on the FID's exhaust gases; therefore, all contaminants are precombusted by the FID to CO<sub>2</sub> and H<sub>2</sub>O.

The first few peaks in the 8021 standard, including vinyl chloride, are of special interest to many analysts. The chromatogram to the left shows the expanded detail of the first few peaks in the analysis (the VOC gases). Note the exceptionally good resolution and peak shape delivered by the SRI system with its dual trap technology.

- 8690-0052**      **Method 5030/5035 Compliant Purge & Trap**  
(with interchangeable purge heads)
- 8690-0051**      **Method 5030 Compliant Purge & Trap**

# Heated Static Headspace Injector



- Uses standard 40mL VOA vials
- VOA Vial Sleeve thermostatted from Ambient to 90°C
- Gas Sampling Valve with fixed volume Loop
- Gauge displays Actual Vial Pressure
- Liquid, Solid, or Powder samples
- Complete PeakSimple Control

The Heated Static Headspace Injector is useful for the analysis of volatiles, especially where the sample matrix is dirty. A 10-port gas sampling valve and fixed sample loop are used for maximum precision.

The thermostatted headspace sleeve accepts standard 40mL VOA vials with 10-20 mLs of sample.

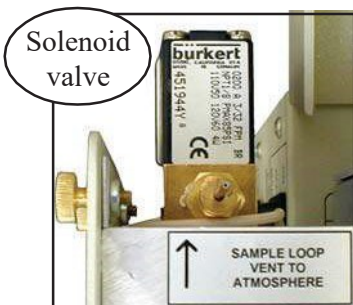

As the vial is inserted into the headspace sleeve, two needles puncture the septum top of the vial. Purge gas enters through one needle to pressurize the vial, and the other needle carries headspace vapors to the loop of the gas sampling valve. A solenoid valve located at the loop exit is opened under PeakSimple data system control to allow headspace vapors to purge through the loop just prior to injecting the loop contents onto the column. The entire headspace sleeve is mechanically agitated under control of the data system.

The headspace sleeve is thermostatted from ambient to 90°C under PeakSimple data system control, and can be cooled down before removing the VOA vial.

8690-0045

Heated Static Headspace Injector

# HT2000H Headspace Autosampler

- Interfaces with SRI and other GCs
- Holds 42 Standard 6/10/20mL Headspace Vials
- Injects Directly into the GC—No transfer lines
- 6 Position Incubator with Orbital Shaking
- Progressive Sample Transfer



It supports a 42 positions removable sample rack for 6, 10 or 20ml vials. The sample rack can be removed for sample loading or preparation, or to be stored elsewhere.

The HT2000H is the most compact autosampler on the market (no requirement for additional bench space, or for GC injector modification).

It fits all GC and GC/MS systems, available on the market - more or less recent.

It can use both the front and rear injector on the most of the supported GC. The injector selection is made directly by the sequence list, avoiding difficult set up operations or re-installation to pass from one injector to another one. Furthermore, rotating head design assures that the injection port is always free, for eventual manual injections.

## COMPARE MODELS

	HT2100H	HT2000H	HT2000HT
Sample Capacity	14 samples: 20 or 10ml	42 samples: 20, 10 or 6ml	42 samples: 20, 10 or 6ml
Removable Rack	-	✓	✓
User Interface	Keypad	Touch Screen	Touch Screen
Oven Position(s)	1	6	3
Oven Temperature Range	Off; 40-150°C	Off; 40-170°C	Off; 40-300°C
Shaking Capability	YES (Sussultatory)	YES (Orbital)	YES (Orbital)
Programmable Injection Volume	✓	✓	✓
Supported Headspace Syringe	1, 2.5 and 5ml	1, 2.5 and 5ml	1, 2.5 and 5ml
Software: HTA Autosampler Manager (Standard Version)	Included	Free trial (60 days)	Free trial (60 days)

HT2000H

HTA 42-Vial Headspace Autosampler

## HT3000A Liquid Autosampler



- Holds 121 2mL vials
- Interfaces with SRI and other GCs
- 15-Step Automatic Injection Sequence
- Direct Injection, No Transfer Lines

Just load your samples and run the analysis with no extra down time.

HTA is the first to offer GC liquid autosampler with a large, full-color touch screen interface, providing easier system accessibility and usability. In fact touch screen eliminates drilldown, simplifying instrument control for novices and experienced users.

HT3000A is the most compact autosampler on the market (no requirement for additional bench space) while offering top-class sample capacity. HT3000A is available in the standard version with 121 positions for 2ml vials, while optional racks are also available. For different sample capacity please check HT3100A (15 vials) or HT3200A (209 vials).

Applications:

- sampling: ambient headspace, multi-phase, small volume;
- injection: priority, with the internal standard technique, dual simultaneous injections (high-throughput and confirmation mode);
- controlled sampling speeds to work with a wide range of sample viscosities;
- syringe washes: with sample or with solvent, single or double wash step capability;

HT3000A

HTA 121-Vial Liquid Autosampler

## AS-210 Greenhouse Workstation

- 210 Positions Headspace Vials or 360 Positions Labco Exetainer
- Combinable with all GC's which are fit with a 10-Port-Valve and Sample-Loop
- 4 Methodes
- Direct connection of up to 4 Calibration Gases



- 4 methods
- 9 sequences
- Openly programmable step rates
- User-specific rack size possible
- Maximum path X= 380 mm Y=480 mm Z= 150 mm
- 4.3" Touch Screen
- System can be purged with Nitrogen
- Evacuation of sample system with rotary vacuum pump (down to 2 mbar)
- Pressure control by sensor
- Up to 4 calibration gases can be used
- Can be used with each GC which is equipped with a sample loop

# AS-210 Greenhouse Workstation

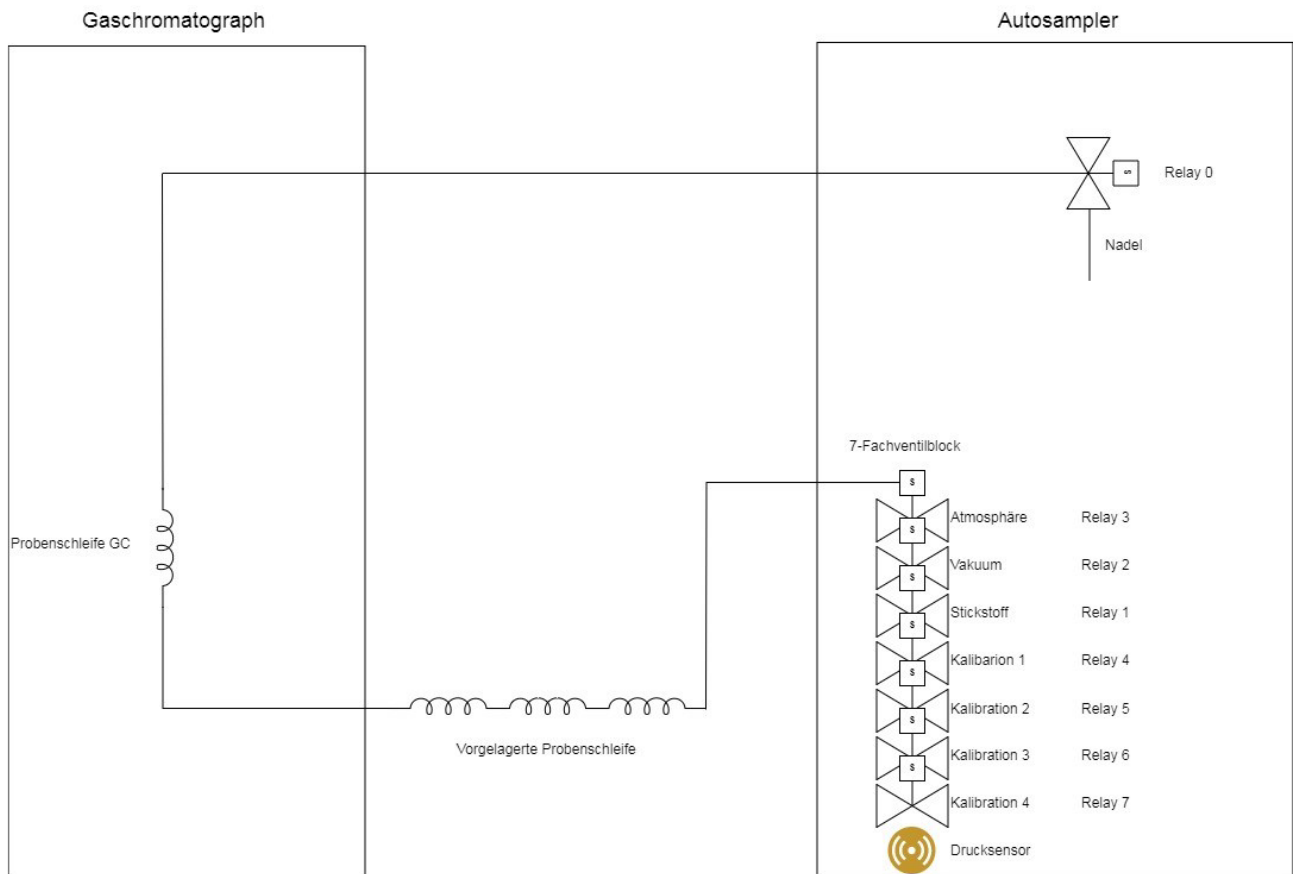

## Theory of sampling:

1. System flushed with Nitrogen
2. Evacuation of sample system
3. Needle pierces Vial - sample streams to the evacuated system
4. Pressure compensation to ambient pressure
5. Pre sample loop avoids that ambient is coming to the sample loop

## Online Sampler for Purge & Trap

- For use with SRI Method 5030 Purge & Trap
- Automatically fills and empties the Purge Vessel
- Valve and 5mL loop for precise sampling
- Data System Control



The Online Sampler for Purge & Trap is designed for applications where a single water stream needs to be measured automatically and repeatedly by purge & trap. The Online Sampler automatically fills and empties the test tube purge vessel of the SRI Method 5030 Purge & Trap with a precisely metered 5mL volume of water. This is useful when monitoring a single stream of contaminated groundwater, or a wastewater stream. A valve with a 5mL loop, special plumbing, and a custom purge head make up the Online Sampler. The stream to be monitored is plumbed to the Online Sampler and a 10-100mL/minute flow is established to continuously flush the 5mL loop with fresh sample.

When used with an SRI Purge & Trap GC, the PeakSimple data system controls the sampler to transfer the 5mL loop contents into the purge vessel of the purge & trap. When the purge is complete, the purge vessel is emptied to waste.

The valve may be optionally configured with a second loop so that an internal standard can be injected along with the water sample.

8690-0075

Online Sampler for Purge & Trap



## Methanizer (for low level CO and CO<sub>2</sub> by FID)



- Converts CO & CO<sub>2</sub> to Methane without changing retention times
- Enables the FID Detector to detect low levels of CO & CO<sub>2</sub>
- Three possible configurations for your application needs
- Thermostatted to 380°C

The Methanizer option enables the Flame Ionization Detector to detect low levels of CO and CO<sub>2</sub>. The Methanizer is packed with a nickel catalyst powder. During analysis, the Methanizer is heated to 380°C. When the column effluent mixes with the FID hydrogen supply and passes through the Methanizer, CO and CO<sub>2</sub> are converted to methane.

Since the conversion of CO and CO<sub>2</sub> to methane occurs after the sample compounds have passed through the column, their retention times are unchanged. Hydrocarbons pass through the Methanizer unaffected. The special Methanizer FID detector assembly operates like the regular FID detector, except that the FID temperature must be set to 380°C. Due to the chemical relationship between nickel and sulfur, the Methanizer can be poisoned by large quantities of sulfur gas.

The Methanizer accessory is available in three configurations:

1. Built into the FID detector.
2. Built into the valve oven ducts on the side of an 8610 GC.
3. As a stand-alone unit for use with any FID detector.

When choosing the second option, a valve oven must also be ordered (part #8690-0088; see price list below).

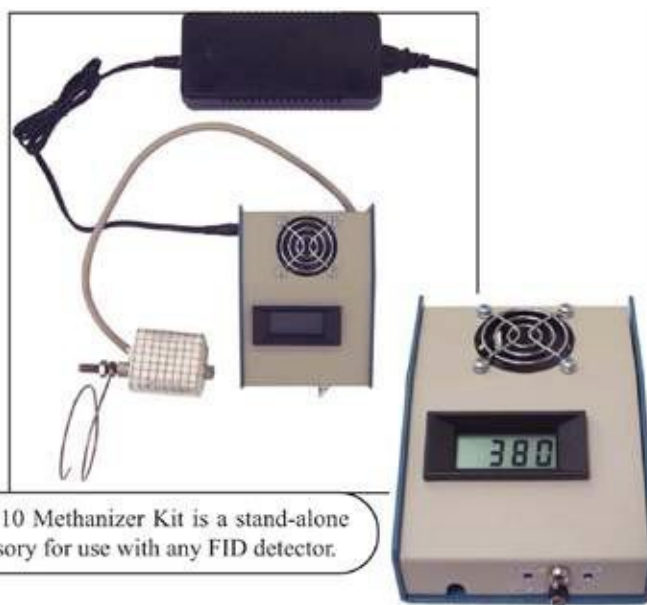

The 510 Methanizer Kit is a stand-alone accessory for use with any FID detector.

8690-0082	Methanizer Jet installed in special FID detector body
8670-1082	Replacement Methanizer Jet
8690-0081	Methanizer accessory built into valve oven
8690-0088	Heated, thermostatted valve oven mounted on an 8610C GC
8670-1081	Replacement Methanizer tube
0510-0081	510 stand-alone Methanizer Kit for use with any FID
0510-1081	510 Methanizer replacement tube

# Hydrogen/Hydrocarbon Leak Detector/Monitor

- Detects Hydrogen and Hydrocarbons down to 500ppm
- Find Leaks or monitor H<sub>2</sub> and HC concentrations
- General purpose Voltmeter included



The Hydrogen/Hydrocarbon Leak Detector & Monitor is useful for sniffing the fittings on your GC for leaking hydrogen or Argon/Methane. It can also be used for detecting leaking natural gas, propane, or other volatile hydrocarbons. Detection limit is approximately 500ppm. The H<sub>2</sub>/HC Leak Detector is also useful for long term monitoring of hydrocarbon concentrations in a flowing stream or static chamber. The sensor element is the same CCD (Catalytic Combustion Detector) that is used as a GC detector on SRI GCs.

The leak detector is attached to the included voltmeter to provide a digital readout. As the H<sub>2</sub>/HC concentration increases, the voltmeter numbers increase. By utilizing a voltmeter as a readout device, the cost of the leak detector can be kept low. Unlike other leak detectors which use a row of LEDs as a low resolution readout, the voltmeter's high resolution display allows the user to notice small changes which would be hard to see on an LED display. The 115 volt AC unit comes with a 9 volt power supply, but can also be run on battery power using any battery source with voltage between 8 and 15 volts DC. Power consumption is approximately 200 milliamps. The H<sub>2</sub>/HC leak detector can also be built into the Model 203 PeakSimple data system for longer term strip-charting, monitoring, or data logging.

8690-5600  
8600-5655

Hydrogen/Hydrocarbon Leak Detector/Monitor (115 volt AC)  
Model 333 PeakSimple Data System with Hydrogen/Hydrocarbon  
Sensor installed

# Sample Stream Dryer



- Uses rechargeable Molecular Sieve dessicant beads and Nafion tubing
- Water is absorbed while gases pass through unaffected
- For use with water sensitive columns
- A simple, economic way to dry gas samples for GC



8670-5850

Sample Stream Dryer

## Built-in “Whisper Quiet” Air Compressor

- Built into the GC Chassis
- Powerful enough to supply FID air (300mL/minute)
- Convenient—Recommended for Field Work

The Built-in “Whisper Quiet” Air Compressor provides an infinite and nearly silent supply of air for the FID, FID/DELCD, NPD, FPD, TID, or CCD detector. It mounts unobtrusively inside the 8610 or 310 GC chassis, and delivers unfiltered air to the detector.



With the built-in air compressor, no air cylinders are required. This simplifies field operations, and saves the expense of regularly replacing air cylinders.

8690-0070	Built-in “Whisper Quiet” Air Compressor
8690-2270	Same as above but 230 VAC

## Vacuum Pump Interface

- Draw air samples through traps or load the loop of a gas sampling valve
- Retrofit Tekmar, O.I., & SRI Purge & Trap Systems
- Thermostatted & Mechanically Agitated VOA vial sleeve

The Vacuum Pump Interface is a data system controlled main power outlet (115 or 230 VAC) on the side of an 8610 or 310 GC for an external vacuum pump. The PeakSimple data system can turn the power to this receptacle ON/OFF, thus controlling the vacuum pump.

Typically, the vacuum pump is used to draw gaseous samples through the traps for ambient air monitoring applications, or to load the loop of a gas sampling valve by pulling sample gas from a remote location.

Because the vacuum pump can be turned ON for a precise length of time, the gas flow through the traps is very reproducible (approximately 100mL/minute).

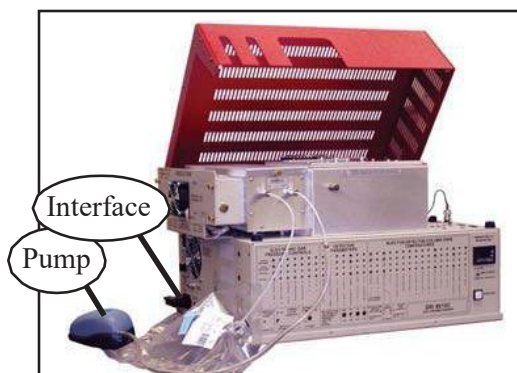

8690-0073	Vacuum Pump Interface and Pump
-----------	--------------------------------

# PeakSimple Chromatography Data Systems



6 channel data system built into an 8610C GC

- Built into Every SRI GC
- Available separately for use with most GCs and HPLCs
- Easy Connection to your Windows™ PC
- 1 and 6 Channel Models available
- PeakSimple Software Included

6 channel stand-alone data system



PeakSimple Chromatography Data Systems consist of hardware and software. The hardware is available as a stand-alone data system for connection to almost any model GC, HPLC or CE system. The same hardware is supplied as standard equipment with every SRI HPLC, 8610 and 310 GC. No hardware is installed in your computer, so a portable laptop may be used instead of a full-sized desktop PC. PeakSimple chromatography acquisition and integration software for Windows is provided with each data system, and updates are FREE from the SRI website: [www.srigc.com](http://www.srigc.com).

The data system hardware comes in two versions:

- 1) 1 channel USB Model 333 for one detector
- 2) 6 channel USB Model 302 for up to 6 detectors on 1-4 instruments

Both models use the same PeakSimple software.



# Model 333 Single Channel Data System

- Easy USB Connection to your Windows™ PC
- Eight TTL Outputs and One Remote Start Input
- Four optional Contact Closures
- Includes PeakSimple Software

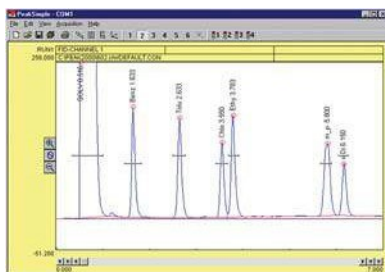
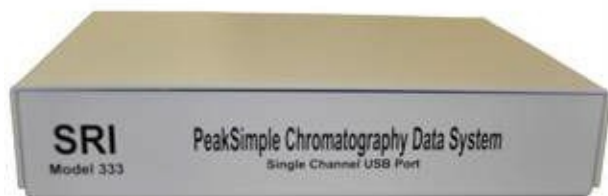

The Model 333 is standard in every 8610, 410 or 310 GC and 210 HPLC. It can also be mounted in a separate box, ready for connection to other manufacturers' GC detectors. The Model 333 Data System consists of PeakSimple for Windows software and a single channel, 20-bit high resolution A/D board.

When mounted in an SRI GC, the Model 333 controls the column oven temperature program, and the pressure program of the carrier gas electronic pressure controller (EPC). The eight available TTL outputs are connected internally within the GC to control functions such as valve rotation, gas solenoid actuation, autosampler injection, etc.

When mounted in a separate box, the temperature and pressure control outputs are available for use, but not connected to anything. The eight TTL outputs can optionally be wired to a bank of four single-pole, dual-throw mechanical relays with screw terminals for easy connection to any user device which operates from a contact closure. A remote start input allows run initiation from the user's GC. Data can be acquired at rates up to 50Hz.

The 230 volt system is supplied with a UL, CSA, and CE/VDE approved universal power supply, which will operate on any AC voltage from 100-250 volts. For computers with USB ports only.

8600-1050	Model 333 Single Channel Data System
8600-1250	Model 333, 230VAC
8600-1051	Optional 4 Contact Closures

## Model 302 Six Channel USB Data System

- 6 Channels, 4 separate Time Bases, 4 Remote Start Inputs
- Independent Start & Stop times for 4 separate instruments
- Easy USB Connection to your Windows™ PC
- Includes PeakSimple Software

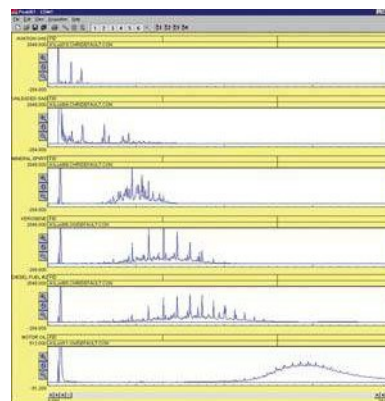
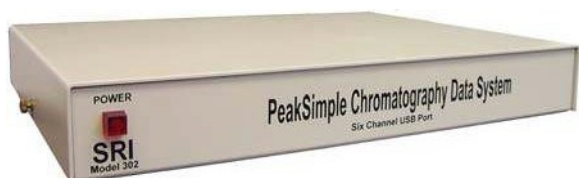

The Model 302 Data System is for analysts who prefer the hot-swappable, plug-and-play capabilities of Universal Serial Bus devices. The Model 302 can be mounted inside the 8610C or 310 GCs, or it can be mounted in a separate box, ready for connection to other manufacturers' GC. The Model 302 Data System consists of PeakSimple for Windows software and a six channel, 24-bit high resolution A/D board.

When mounted in an SRI GC, the Model 302 controls the column oven temperature programs, and the pressure program of the carrier gas electronic pressure controller (EPC). When mounted in the Model 210 HPLC system, the Model 302 controls the pump speed and gradient profile. The eight available TTL outputs are connected internally within the GC or HPLC to control functions such as valve rotation, gas solenoid actuation, autosampler injection, etc.

When mounted in a separate box, the temperature, pressure, and gradient control outputs are available for use, but not connected to anything. The eight TTL outputs are wired to a bank of eight single-pole, dual-throw mechanical relays with screw terminals for easy connection to any user device which operates from a contact closure. Four remote start inputs allow run initiation from the user's GC.

Each of the six channels of data can be randomly assigned to one of four time bases, which allows independent start and stop times for four separate instruments. Data can be acquired at rates up to 50Hz per channel for 1 or 2 channels, or 20Hz for all 6 channels. The Model 302 is for use with Windows computers that have USB 2.0 ports (manufactured in 1998 or later).

8600-6055

Model 302 Six Channel USB Data System, 115VAC

8600-6255

Model 302 Six Channel USB Data System, 230VAC

# PeakSimple for Windows™ Software



- Easy USB Connection to your Windows™ PC
- Eight TTL Outputs and One Remote Start Input
- Four optional Contact Closures
- Includes PeakSimple Software

PeakSimple software has been continuously developed, refined, and improved since 1988 by a dedicated team of working chromatographers. These chromatographers use the software on a daily basis, and strive to simplify and enhance every aspect of PeakSimple so our customers will benefit. New features are added to PeakSimple several times per year, and the latest version is always FREE to download online, along with helpful tutorials. When you call SRI technical support, a knowledgeable technician will answer your questions right away. No complicated phone menus, and no waiting on hold!

## FEATURES

- |                                    |                              |
|------------------------------------|------------------------------|
| • 3D Multiple Chromatogram Display | • Report Generation          |
| • Built-in FTP capability          | • Multi-level Calibrations   |
| • Click & Drag Retention Windows   | • Data Merge across channels |
| • Baseline Subtraction             | • Autosampler Queue          |
| • Chromatogram Overlay             | • Batch Reprocessing         |
| • DDE Links                        | • Built-in Data Validation   |
| • Peak Alarms                      | ...and more!                 |

Most PeakSimple functions are launched from the chromatogram window, and are so user friendly that most operators can produce results almost immediately. ToolTips makes learning your way around PeakSimple even easier—just hold your mouse cursor over any icon or checkbox to read the onscreen How-To instructions.

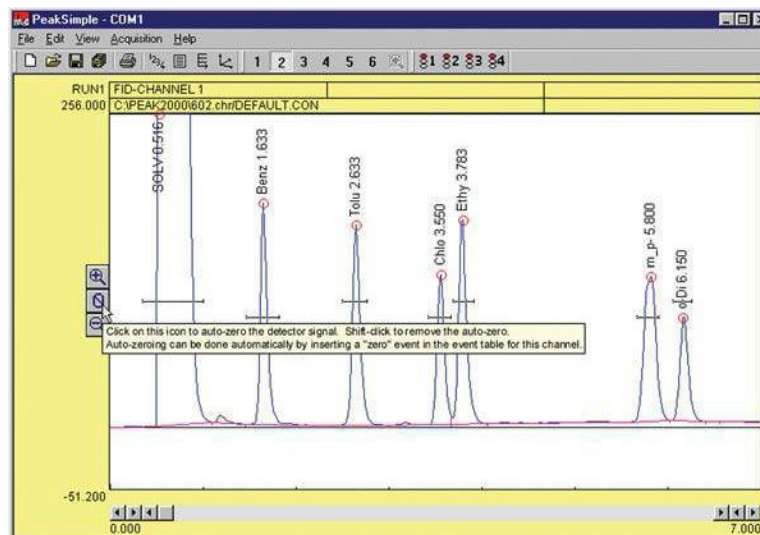

# PeakSimple Software Features

## 3D MULTIPLE CHROMATOGRAM DISPLAY

Right-click in any channel window to load its data into the 3D display feature. Click on the 3D icon  to display multiple chromatogram traces in orthographic or perspective renditions, with Auto-scaling and Zoom. Add, delete, and

arrange the displayed chromatograms using the buttons in the 3D display window. The point of view may be placed at any point on an imaginary sphere around the data, using the click-and-drag interface—almost like flying around the data in a helicopter. Grab the 3D display with your mouse and spin it around in realtime. Print your 3D display, or copy it to your clipboard for pasting into Excel, Word, etc.

Magnify or reduce the 3D display by clicking on the Zoom icons.

Grab the 3D display with your mouse and spin it around in realtime.

## BUILT-IN FTP CAPABILITY

With PeakSimple's FTP capability, you can upload data at the end of every run via the Internet. Using this powerful feature, one person can monitor a GC network around the world. Compared to the ongoing cost of manning each individual instrument, the savings potential is significant.

PeakSimple provides several options for receiving files into the folder of your choice. PeakSimple can automatically check for new files at user-specified intervals. You can choose to automatically add files to a database as they are received, or add them manually with the click of a button. You can even choose to add files to the 3D display as they are received.

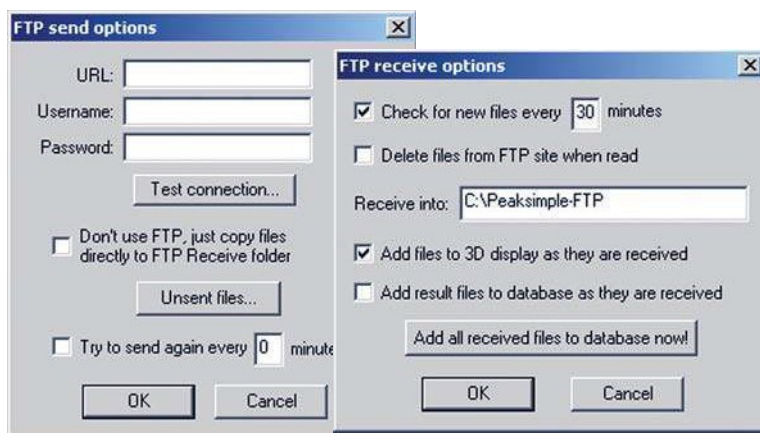

The number of instances of PeakSimple you can have running at one time is limited only by the resources of your computer. Therefore, you could monitor from your lab remote GC systems working anywhere they can connect to the Internet.



# PeakSimple Software Features

## MANUAL INTEGRATION

Manual integration tools allow the user to refine the integration method applied to any peak. Baseline projection may be “rubber-banded” from point to point, forced to a valley, dropped vertically, skimmed, etc. The example below shows the use of the “Drop” tool to drop a vertical line from the valley of the conjoined peaks to the baseline.

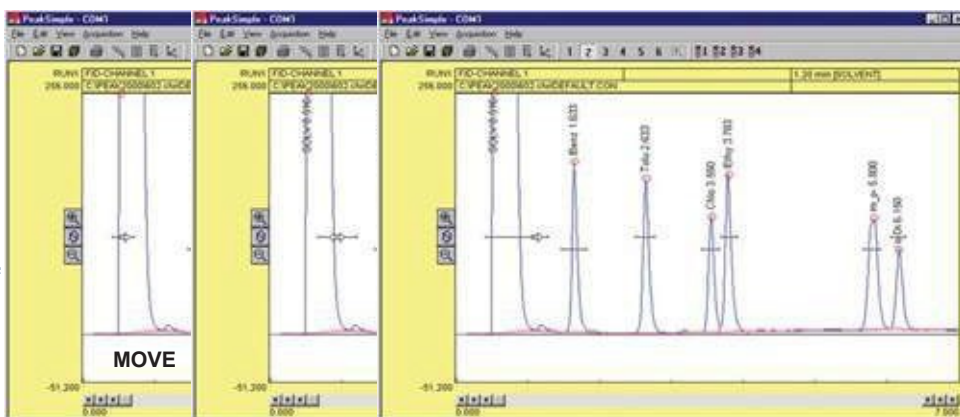
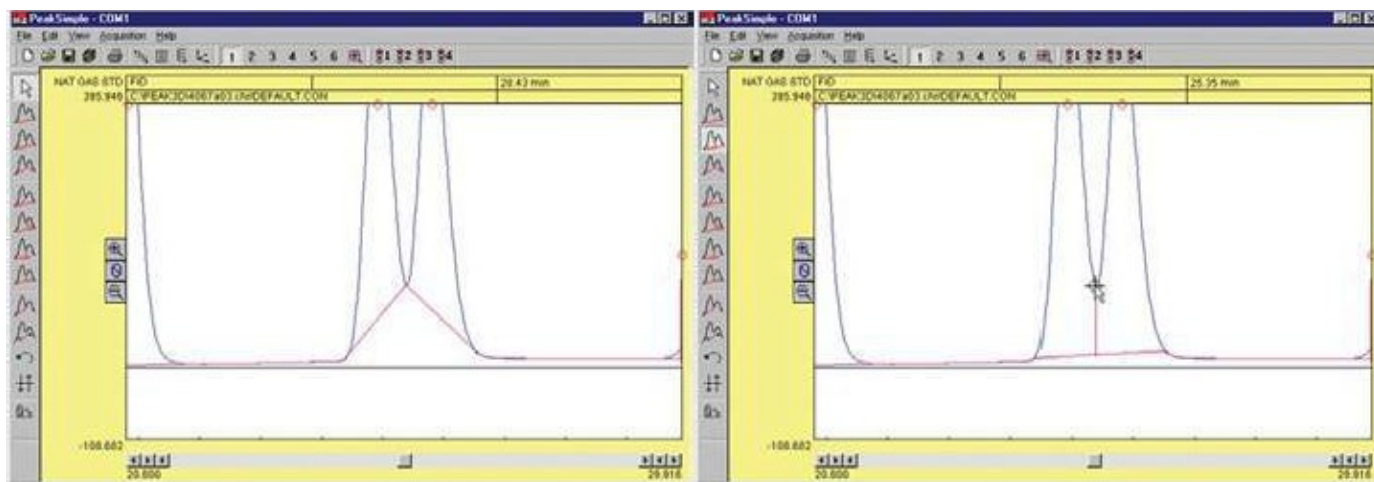

Retention window brackets are visible onscreen and may be grabbed and dragged onto a peak, widened, or narrowed with the mouse. The component table is automatically updated when a retention window is graphically modified.

## CONTROL FILES

Save any changes you make in an analysis to a control file and use it again and again for method reproducibility. Control files contain temperature or gradient programming, component tables, external events, channel details, integration, post-run actions, and more! Create a control file for each method you typically perform. The number of control files you can have is limited only by your disk space.

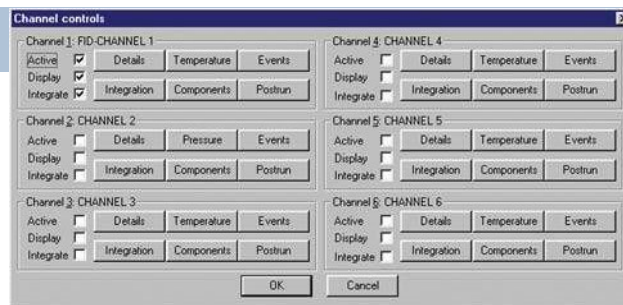

# PeakSimple Software Features

## CONTROL FILES

Operators can set channel parameters for each channel via the Channel details dialog box. Set the sampling rate and default display limits; choose temperature, pressure, or gradient control; subtract the baseline from another channel; overlay the data from another channel; turn Data Logger mode ON or OFF; designate a start time to compensate for relative retention shifts, and more.

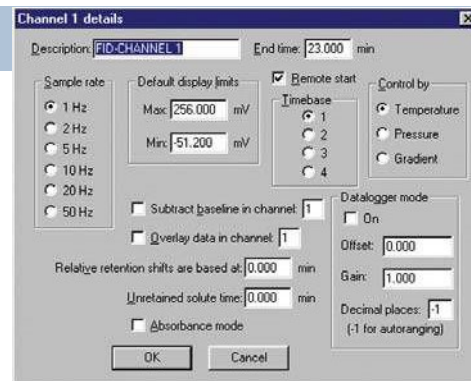

## CONTROL FILES



Program one or two SRI GC column ovens from ambient to 400°C with unlimited ramps and holds, 0.01 degree resolution, and negative programming.

Program the carrier gas pressure with unlimited ramps and holds on SRI GCs equipped with electronic pressure control (EPC).

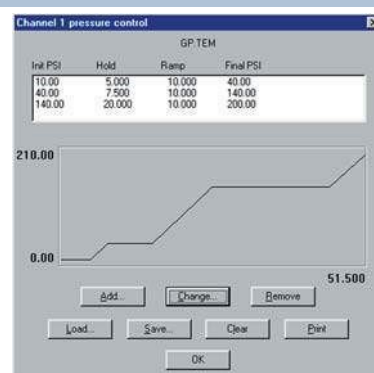

## MANUAL/AUTOMATIC EXTERNAL EVENT CONTROL

In addition to performing timed integration events, control up to eight external contact closure relay outputs to actuate sampling valves, autosamplers, solenoids, pumps, or any external device using TTL or relay contact closure triggers.

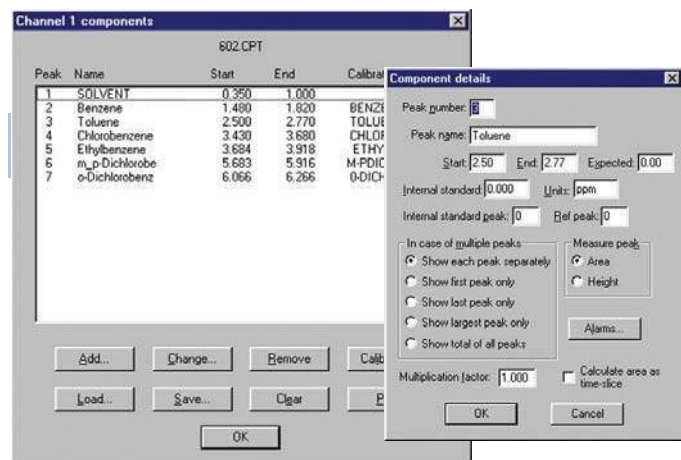
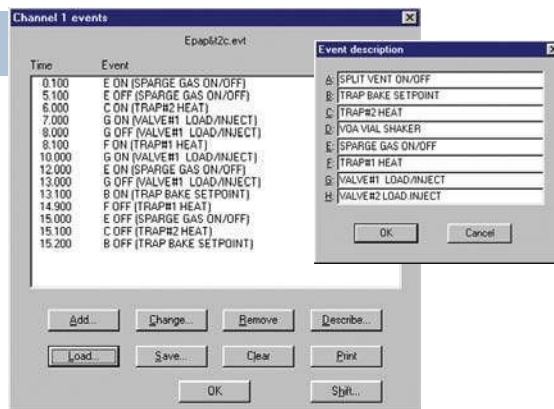

Create, save, and edit component tables with an unlimited number of compounds. Enter expected retention times, control peak display, and more! Component details may be viewed and edited by double-clicking on any retention window in the chromatogram, or by double-clicking on any component in the list.

# PeakSimple Software Features

## ZOOM TWO WAYS

Click and drag the mouse cursor to draw a rectangle around an area you wish to enlarge, and that area will expand to fill the chromatogram window. This may be done multiple times. Clicking on the unzoom icon  in the toolbar unzooms the view one level at a time until it returns to the original resolution.

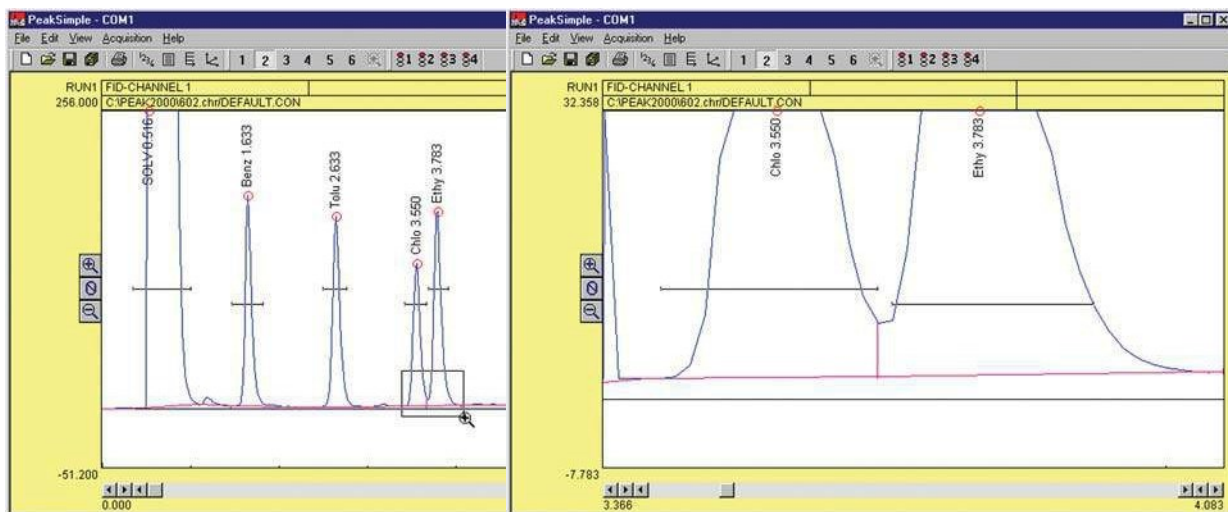

A mouse click on one icon vertically enlarges the peaks in the chromatogram, decreasing the y-axis display limits by a factor of two.

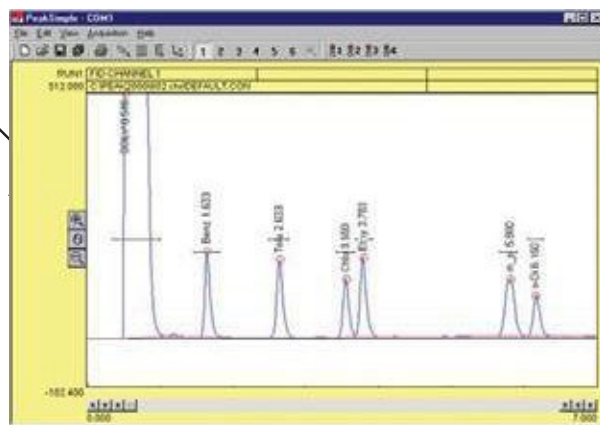
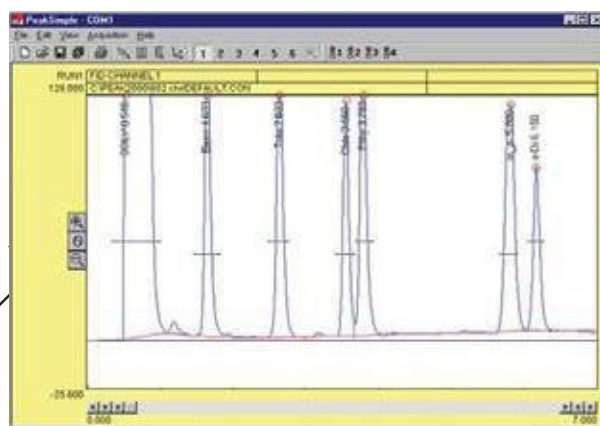
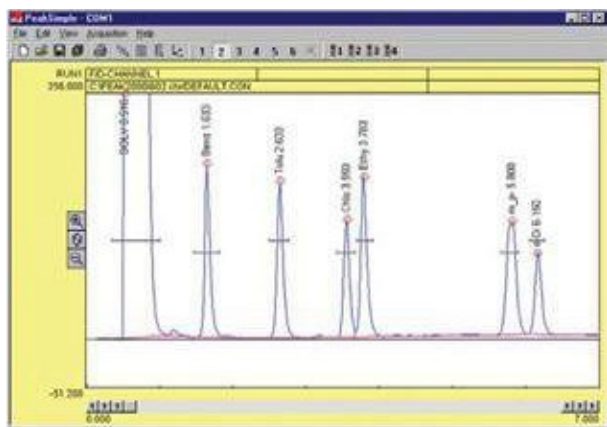

A click on another icon increases the display limits by a factor of two, vertically shrinking the peaks.

# PeakSimple Software Features

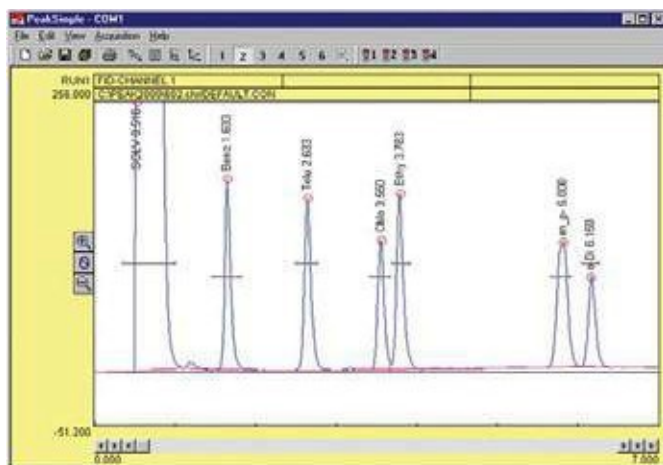

## OVERLAY CHROMATOGRAMS

Overlay the data in any channel onto any other channel for retention time comparison or multiple detector correlation. The Overlay Adjust feature lets you shift and stretch overlaid data for pattern matching.

## BASELINE SUBTRACTION and DATA SMOOTHING

Blank baseline subtraction is useful to compensate for baseline drifting due to column bleed and temperature ramping. PeakSimple lets you subtract baselines in real time as data is collected, or post run.

Noisy detector signals can be smoothed manually or automatically at the end of a run. Smoothing algorithms include Olympian, Moving Average, and Savitsky-Golay.

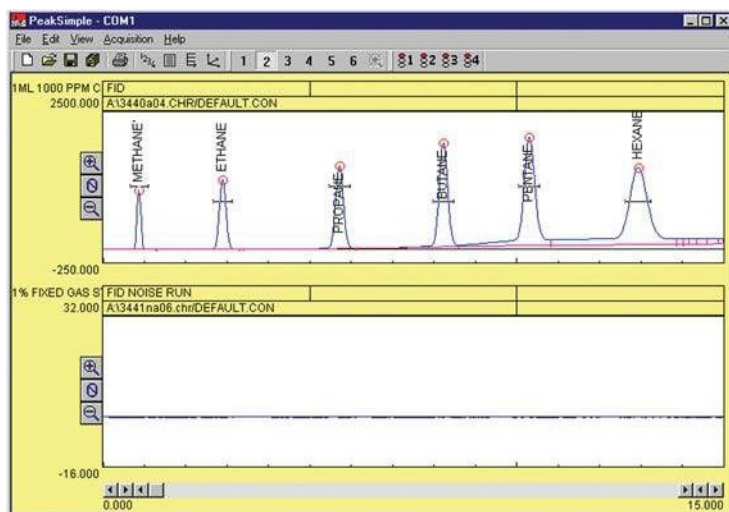

## CALIBRATION

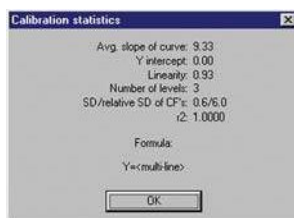
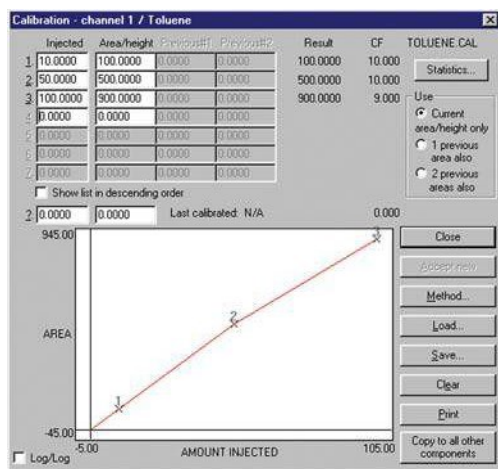

## Calibration Averaging

PeakSimple allows up to three replicate calibration standards at seven levels of concentration to be averaged when constructing calibration curves.

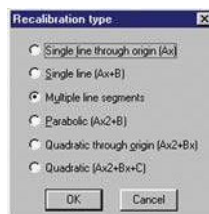

## Multi-Level Calibration Curves

Calibrate peaks six ways (multi-line, quadratic, parabolic, etc) using single or averaged data at up to seven concentration levels. Statistics for evaluating line fit quality, modification date audit trail, and curve printout help to ensure defensible results.

# PeakSimple Software Features

## DYNAMIC DATA EXCHANGE

Link PeakSimple to your DDE compatible spreadsheet or word processor (Excel, Word, etc.). Analytical results are automatically transferred after every run, or may be accumulated within PeakSimple and copied as a block of data. Use the Copy Picture option to paste the chromatogram itself into Excel, etc. along with the results.

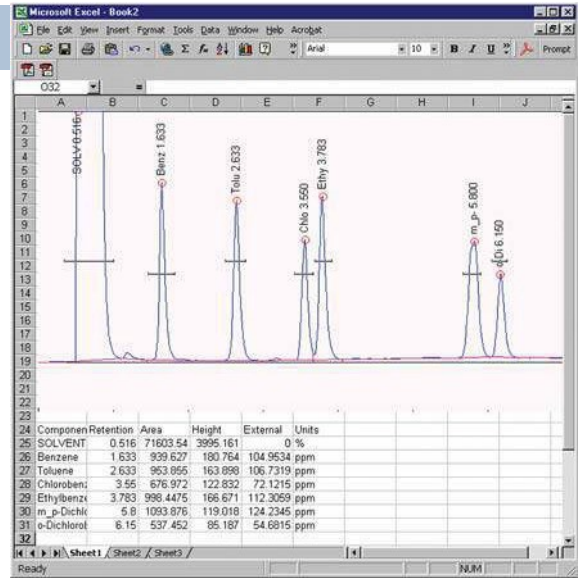

## MERGE RESULTS FROM MULTIPLE CHANNELS

PeakSimple lets you merge the results from any or all channels into one report. This feature is useful for combining results from different detectors for export to Excel, etc.

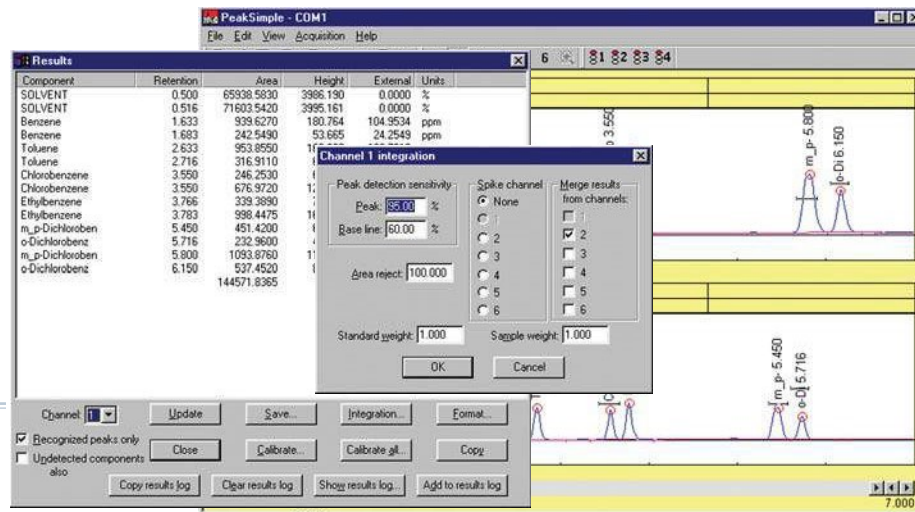

## SELF-VALIDATING HARDWARE

PeakSimple will play back and reacquire any chromatogram multiple times, establishing the precision and accuracy of the data system using real data, not "canned" chromatograms. PeakSimple's validation can be performed by the user anytime, without extra hardware.

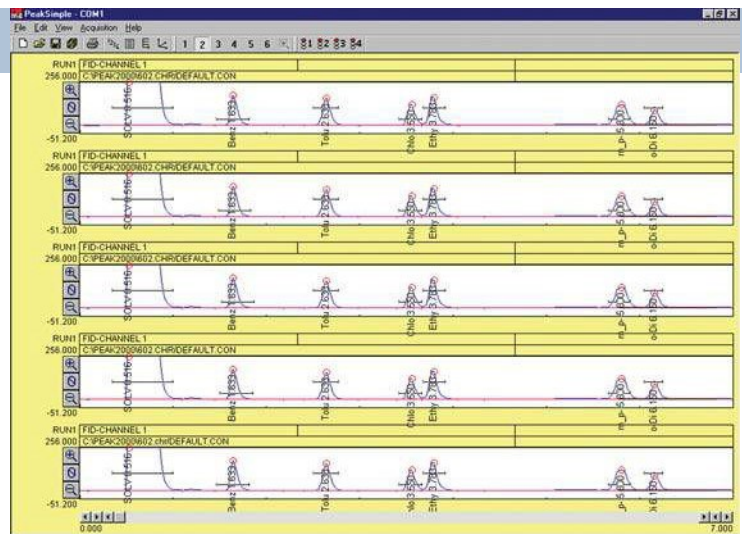

# PeakSimple Software Features

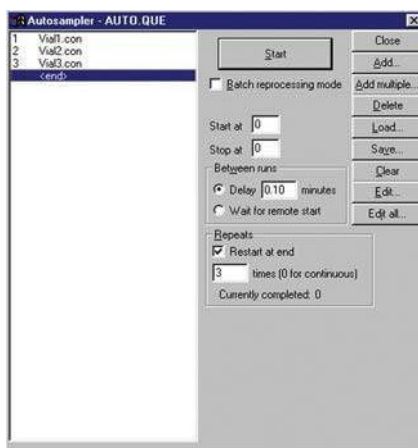

## AUTOSAMPLER QUEUE and BATCH REPROCESSING

Create customized autosampler sequences—for liquid injections, purge and trap autosamplers, gas sampling valves, and stream selectors—including unique, predefined sample information, auto-calibration, and batch reprocessing of previously run samples.

## DATA LOGGER MODE

PeakSimple's Data Logger Mode allows you to display a scaled and calibrated result in large numbers instead of the usual strip chart data presentation. Data Logger Mode is especially useful when monitoring total hydrocarbons on one channel, while performing a separation on another channel.

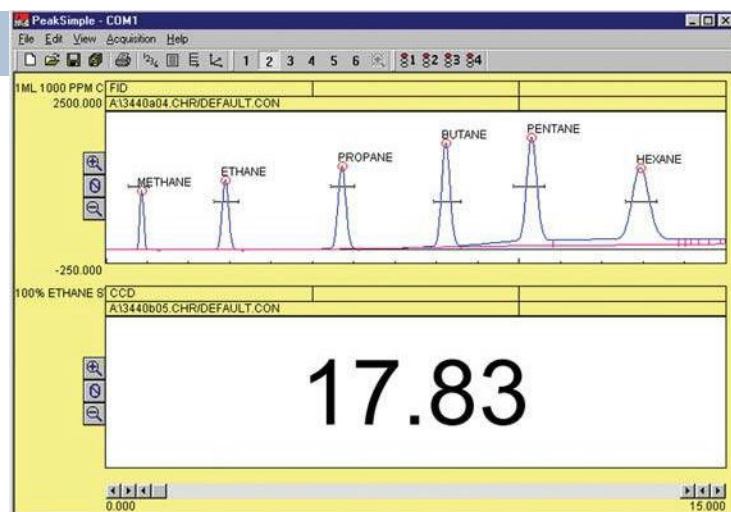

## PRINT CHROMATOGRAMS IN COLOR

Use any Windows supported color printer to create multiple chromatograms per page for easy detector-to-detector comparisons and paperwork consolidation. Print overlaid data in contrasting colors with adjustable line weight.

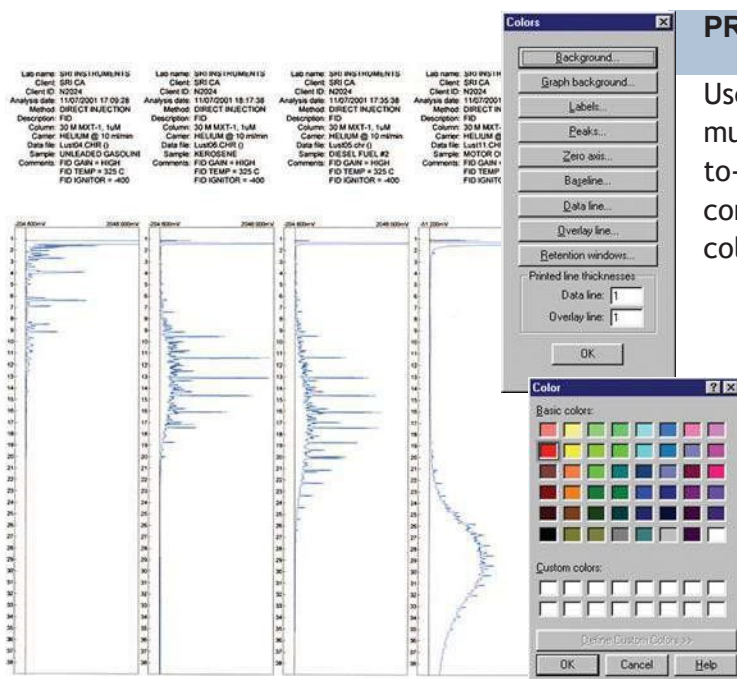

SRI products are CE, TÜV, NRTL, and GS approved, having met all electrical safety requirements. We can ship our products to any destination worldwide, with any voltage. We follow ISO-9000 manufacturing practices, as evidenced by these certifications.



Equivalent to CSA and UL



Upon request, we will provide Certifications and a Declaration of Conformity letter for any instrument we manufacture.

Our knowledgeable and hardworking staff build each SRI instrument at our state-of-the-art facility in Las Vegas, Nevada, USA.



# Warranty

**SRI Instruments | 310-214-5092 20720 Earl Street Torrance, CA 90503 USA**

SRI will repair or replace any defective parts within two years from the date of shipment. Consumable items such as TCD filaments, NPD beads, DELCD heaters, FPD photomultiplier tubes, ECD detector cells, lamps, heaters, septa, traps, filters, columns, syringes, etc, are excluded. Replacement or repair shall be the purchaser's only remedy, and in no case shall SRI's liability exceed the original purchase price. The equipment is purchased without any other warranty expressed or implied, including, without limitation, any warranty of merchantability, any warranty arising from a course of dealing, performance of usage of trade and/or any warranty that the equipment is fit for any particular purpose or trade. The purchaser agrees to assume all risks of defects relating to the design, construction, purchase, operation, condition, maintenance, possession and use of the equipment, and to release SRI, to the maximum extent allowed by law, from any and all liabilities, claims, or demands of any nature, including without limitation any claims based on incidental or consequential damages (foreseeable or not), lost earnings, negligence (active or passive), strict liability, breach of agreement or misconduct. The purchaser is aware of and waives the provisions of California Civil Code Section 1542, ("A general release does not extend to claims which the creditor does not know or suspect to exist in his favor at the time of executing the release, which if known by him must have materially affected his settlement with the debtor"), and/or all other laws, local, state, federal, or international, of similar intent, scope or purpose, relating to the release of unknown or unexpected claims. It is expressly agreed that the possibility of such unknown or undiscovered claims exist. This has been explicitly taken into account in determining the equipment's purchase price. That consideration has been adjusted, having been bargained for in full knowledge of the possibility of such unknown claims. In the event the equipment is sold, loaned, or otherwise transferred, purchaser agrees to bind the third party to the terms of this agreement as a condition of transfer. Purchaser is aware of the dangers, and hazards inherent in operating chromatographs and data systems including but not limited to the warnings listed in the SRI Instruments Products Operation and Service Manual. No agent, representative, distributor, or employee of SRI has authority to amend this warranty in anyway. In the event that any term or provision of this warranty is subject to valid claim of unenforceability, such term or provision shall be narrowly construed, the remaining provisions shall nevertheless survive, granting SRI the greatest possible protection then available under law.



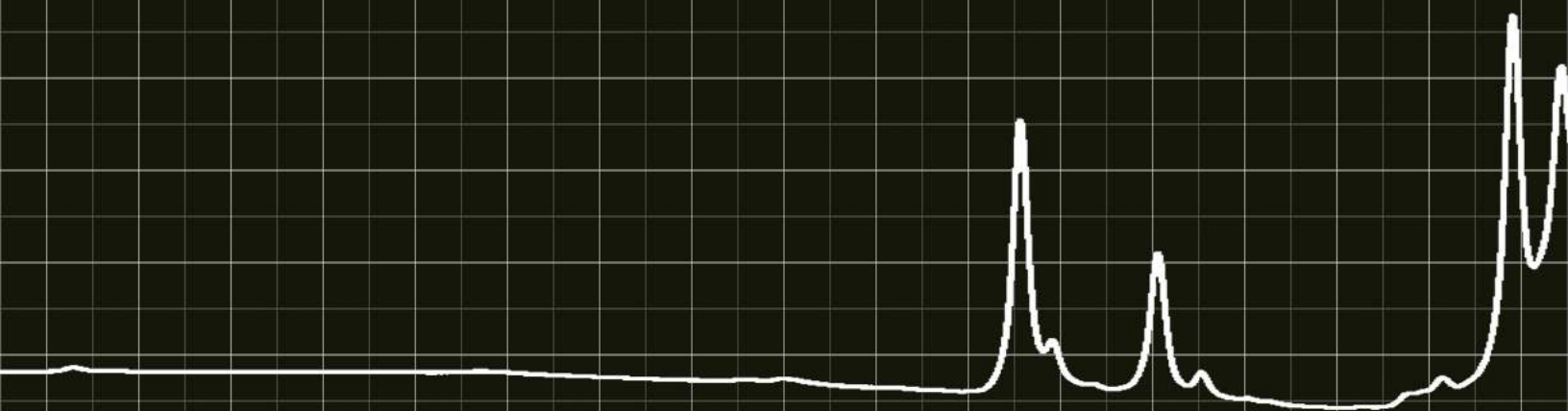

SRI Instruments Europe GmbH  
Drieschweg 13A  
D - 53604 Bad Honnef, Germany  
Phone: +49 2224 766 15  
Fax: +49 2224 988 943

Internet: [www.sri-instruments-europe.com](http://www.sri-instruments-europe.com)  
Email: [mailto@sri-instruments-europe.com](mailto:mailto@sri-instruments-europe.com)