

Instruction Book

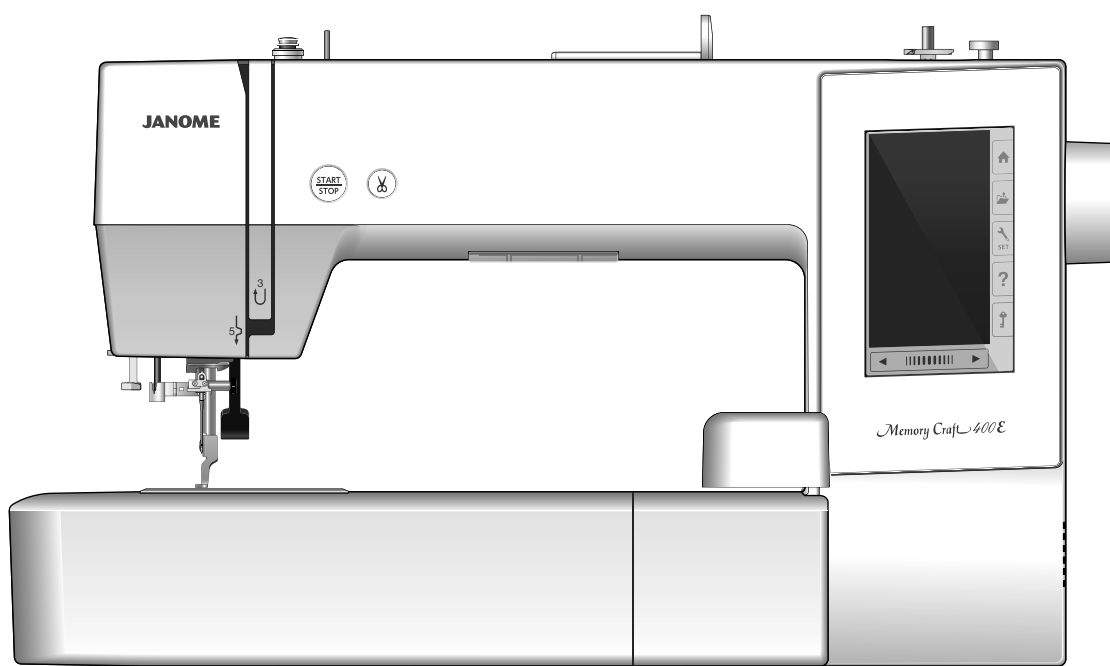

IMPORTANT SAFETY INSTRUCTIONS

When using an electrical appliance, basic safety precautions should always be followed, including the following:

This sewing machine is designed and manufactured for household use only.

Read all instructions before using this sewing machine.

DANGER — To reduce the risk of electric shock:

1. An appliance should never be left unattended when plugged in. Always unplug this sewing machine from the electric outlet immediately after using and before cleaning.

WARNING — To reduce the risk of burns, fire, electric shock, or injury to persons:

1. Do not allow to be used as a toy. Close attention is necessary when this sewing machine is used by or near children.
2. Use this appliance only for its intended use as described in this owner's manual. Use only attachments recommended by the manufacturer as contained in this owner's manual.
3. Never operate this sewing machine if it has a damaged cord or plug, if it is not working properly, if it has been dropped or damaged, or dropped into water. Return this sewing machine to the nearest authorized dealer or service center for examination, repair, electrical or mechanical adjustment.
4. Never operate the appliance with any air opening blocked. Keep ventilation openings of this sewing machine and foot controller free from accumulation of lint, dust and loose cloth.
5. Never drop or insert any object into any opening.
6. Do not use outdoors.
7. Do not operate where aerosol (spray) products are being used or where oxygen is being administered.
8. To disconnect, turn all controls to the off ("O") position, then remove plug from outlet.
9. Do not unplug by pulling on cord. To unplug, grasp the plug, not the cord.
10. Keep fingers away from all moving parts. Special care is required around the sewing machine needle and/or cutting blade.
11. Always use the proper needle plate. The wrong plate can cause the needle to break.
12. Do not use bent needles.
13. Do not pull or push fabric while stitching. It may deflect the needle causing it to break.
14. Switch this sewing machine off ("O") when making any adjustment in the needle area, such as threading the needle, changing the needle, threading the bobbin or changing the presser foot, and the like.
15. Always unplug this sewing machine from the electrical outlet when removing covers, lubricating, or when making any other adjustments mentioned in this owner's manual.

SAVE THESE INSTRUCTIONS

For Europe only:

This appliance can be used by children aged from 8 years and above and persons with reduced physical, sensory or mental capabilities or lack of experience and knowledge if they have been given supervision or instruction concerning use of the appliance in a safe way and understand the hazards involved. Children shall not play with the appliance. Cleaning and user maintenance shall not be made by children without supervision.

For outside Europe (except U.S.A and Canada):

This appliance is not intended for use by persons (including children) with reduced physical, sensory or mental capabilities, or lack of experience and knowledge, unless they have been given supervision or instruction concerning use of the appliance by a person responsible for their safety. Children should be supervised to ensure that they do not play with the appliance.



Please note that on disposal, this product must be safely recycled in accordance with relevant National legislation relating to electrical/electronic products. If in doubt please contact your retailer for guidance. (European Union only)

TABLE OF CONTENTS

GETTING READY TO SEW

Names of Parts.....	3
Standard Accessories	4-5
Connecting the Power Supply	6
Machine Operating Buttons.....	6
Raising and Lowering the Presser Foot	7
Common Keys.....	7
Setting the Spool of Thread	8
Extra spool pin	8
Winding the Bobbin	8-10
Removing the bobbin	8
Winding the bobbin	9
Inserting the bobbin	10
Threading the Machine.....	11
Built-in Needle Threader	12
Replacing Needles	13
Fabric and Needle Chart	13
On-screen Help	14
Removing and Attaching the Embroidery Foot	15
Bobbin Holder for Embroidery (high tension)	16
Embroidery Hoops	16
Stabilizers.....	17
Types of the stabilizers.....	17
Setting the Fabric in an Embroidery Hoop.....	18
Attaching the Embroidery Hoop to the Machine	19
Thread Holder	20
Selecting Built-in Embroidery Designs.....	20
Monogramming	21
Function Keys.....	22
Programming a Monogram.....	23-24
Color change.....	23
Monogram placement	23
2-Letter monogram.....	24
Editing a Monogram	25
Ready to Sew Window	26-31
Function keys	26
Pattern information.....	26
Stitch back/forward keys	27
Jump key	27
Cross mark.....	27
Color section key.....	27
Trace key.....	28
Thread color/Jog key.....	28
Fine position/angle adjustment key.....	29
Rotating a design	29
Moving a design	29
Color list key.....	30
Adjust key.....	30
Auto thread tension level.....	30
Cutting the tails of jump threads.....	30
Hoop back key.....	31
Starting to Sew Embroidery	32
Editing Mode	33-43
Selecting a hoop size	33
Opening the embroidery designs	33
Editing tool bar information.....	34
Selecting a pattern	34
Moving a pattern.....	34
Duplicating a pattern	35
Deleting a pattern.....	35
Resizing a pattern	35
Rotating a pattern.....	36
Flipping a pattern	36
Monogramming in an arc	37

Grouping patterns	38
Customizing the display colors.....	39
Color grouping.....	40
Sewing order	41
Center positioning	41
Creating a square frame.....	42
Single color sewing	42
Zooming in the editing window.....	43
Pantry Designs for Applique.....	44-45
Alternative method	45
Celebration Designs.....	46
Bracelet Designs	47

CUSTOMIZING MACHINE SETTINGS

Machine Setting Mode	48
Registering the custom settings.....	48
Common Setting Mode	49-50

CUSTOMIZING EMBROIDERY MODE SETTINGS

Embroidery Mode Settings.....	51-54
Language Selection Mode	54
Saving and Opening a File.....	55
Creating a new folder	55
Deleting a file or folder	56
Opening a file	56
Changing a name of the file or folder	57

CARE AND MAINTENANCE

Cleaning the Hook Area	58
Cleaning the Thread Path	59
Oiling the Machine.....	60-64
Troubleshooting.....	65

GETTING READY TO SEW

Names of Parts

- ① Thread take-up lever
- ② Upper thread guide
- ③ Pre-tension thread guide
- ④ Bobbin winder thread guide
- ⑤ Spool pin
- ⑥ Spool holder (large)
- ⑦ Hole for extra spool pin
- ⑧ Bobbin thread cutter
- ⑨ Bobbin winder spindle
- ⑩ Bobbin winder stopper

- ⑪ Face plate
- ⑫ Start/stop button
- ⑬ Thread cutter button
- ⑭ Visual touch screen
- ⑮ Carriage

- ⑯ Thread cutter/holder
- ⑰ Needle threader
- ⑱ Setscrew
- ⑲ Embroidery foot
- ⑳ Needle plate
- ㉑ Thread cutter
- ㉒ Lower thread guide
- ㉓ Needle clamp screw
- ㉔ Needle
- ㉕ Hook cover plate
- ㉖ Hook cover release button

- ㉗ Carrying handle
- ㉘ Handwheel
- ㉙ Touch panel stylus holder
- ㉚ USB port (type A)
- ㉛ Presser foot lifter
- ㉜ Power switch
- ㉝ Power inlet

NOTE:

To carry the sewing machine, hold the carrying handle with your hand, and support the sewing machine with the other hand.

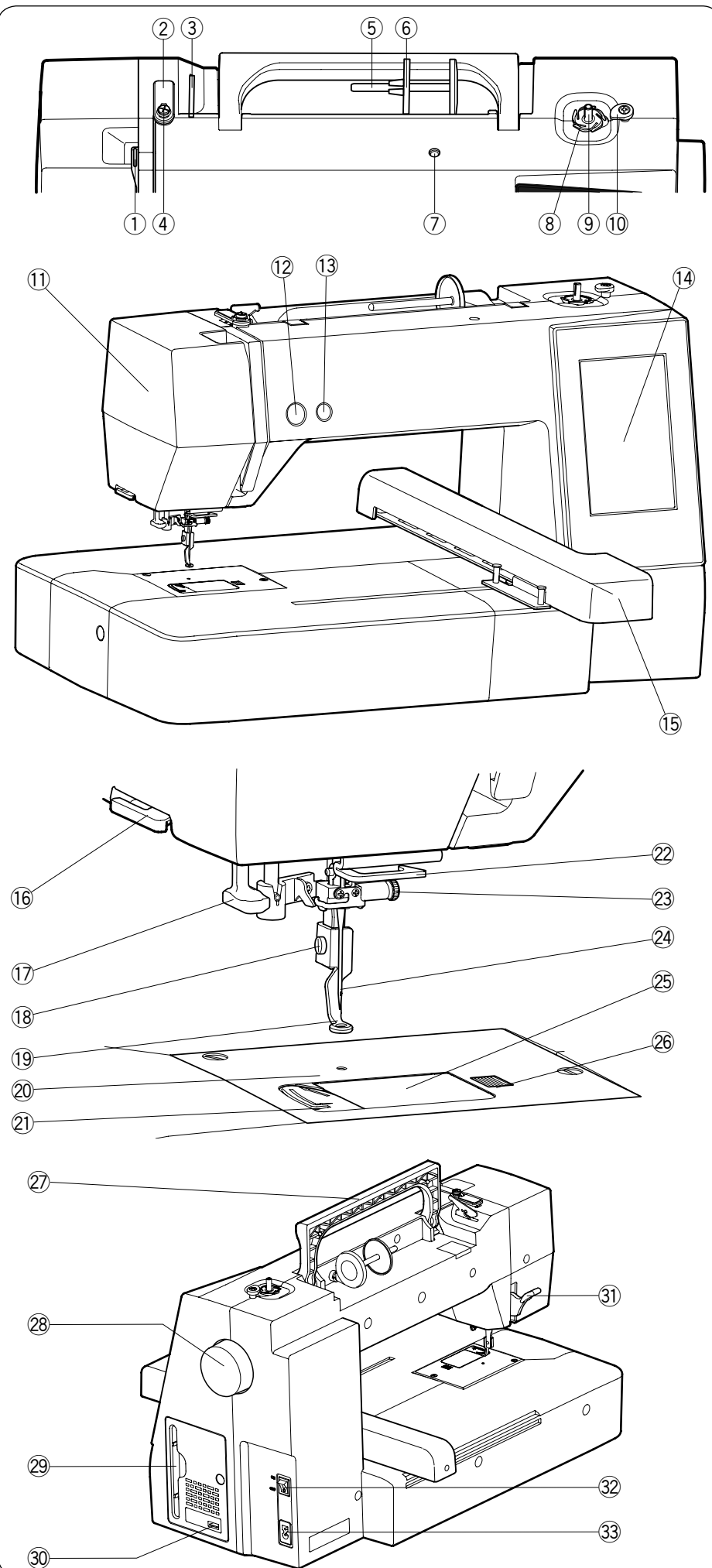

* Design and specifications are subject to change without prior notice.

Standard Accessories

- ① Bobbin x 5 (1 set on the machine)
- ② Screwdriver (Large)
- ③ Screwdriver key (for needle plate)
- ④ Lint brush
- ⑤ Scissors
- ⑥ Needle set
- ⑦ Spool holder (large) X 2 (1 set on the machine)
- ⑧ Spool holder (small) X 2
- ⑨ Spool holder (special) X 2
- ⑩ Extra spool pin
- ⑪ Special bobbin holder for Embroidery (high tension)*
- ⑫ Touch panel stylus
- ⑬ Bobbin holder cleaner
- ⑭ Instruction book
- ⑮ Quick reference guide
- ⑯ Template CD
- ⑰ Instructional DVD
- ⑱ Soft machine cover
- ⑲ Power cable**

* Set on the machine for some models.

** The power cable included may differ from the illustration.

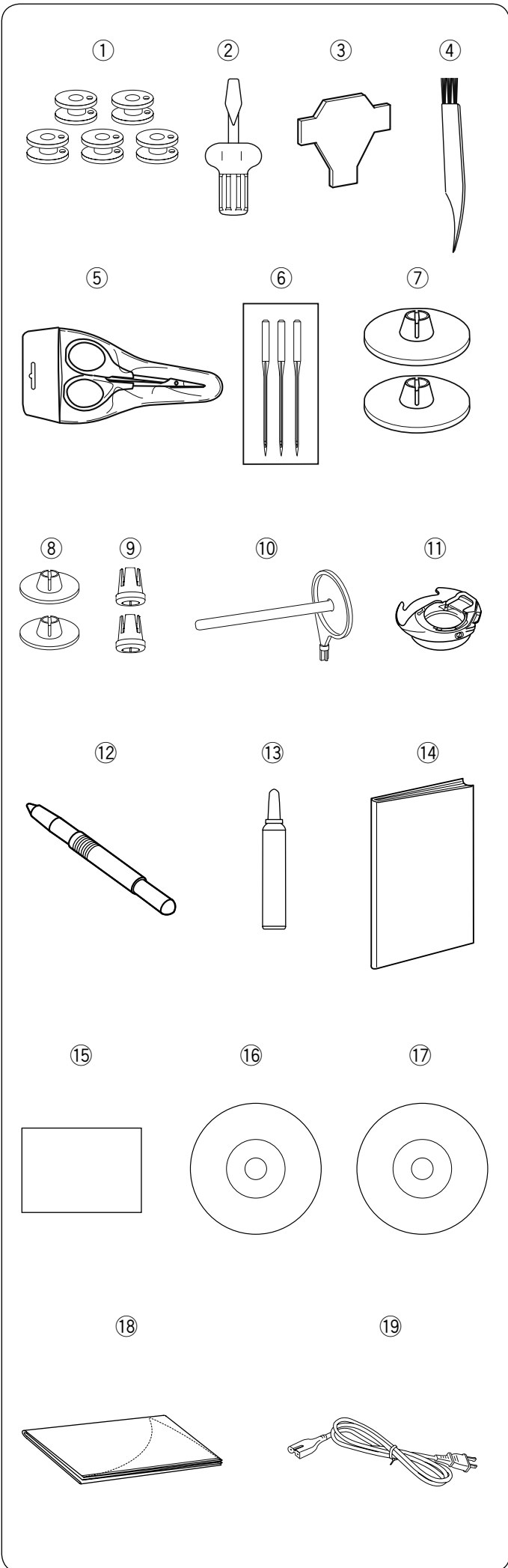

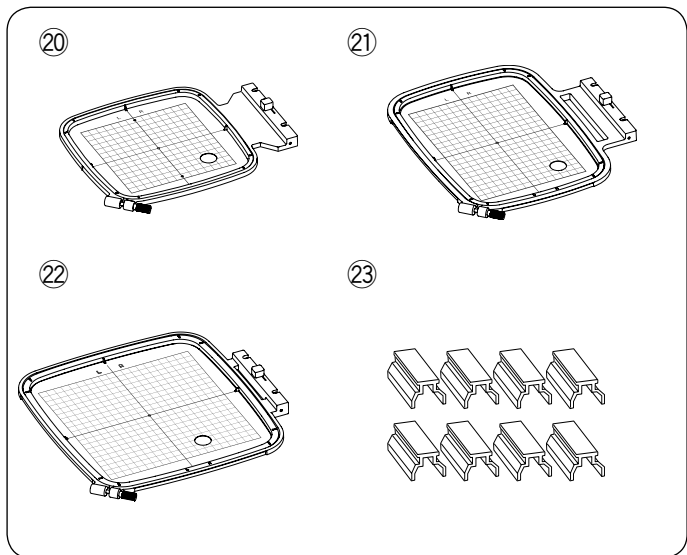

- ⑳ Embroidery hoop SQ14b (with template)***
- ㉑ Embroidery hoop RE20b (with template)***
- ㉒ Embroidery hoop SQ20b (with template)***
- ㉓ Clamp X 8

*** The embroidery hoops supplied with your machine vary depending on your model.

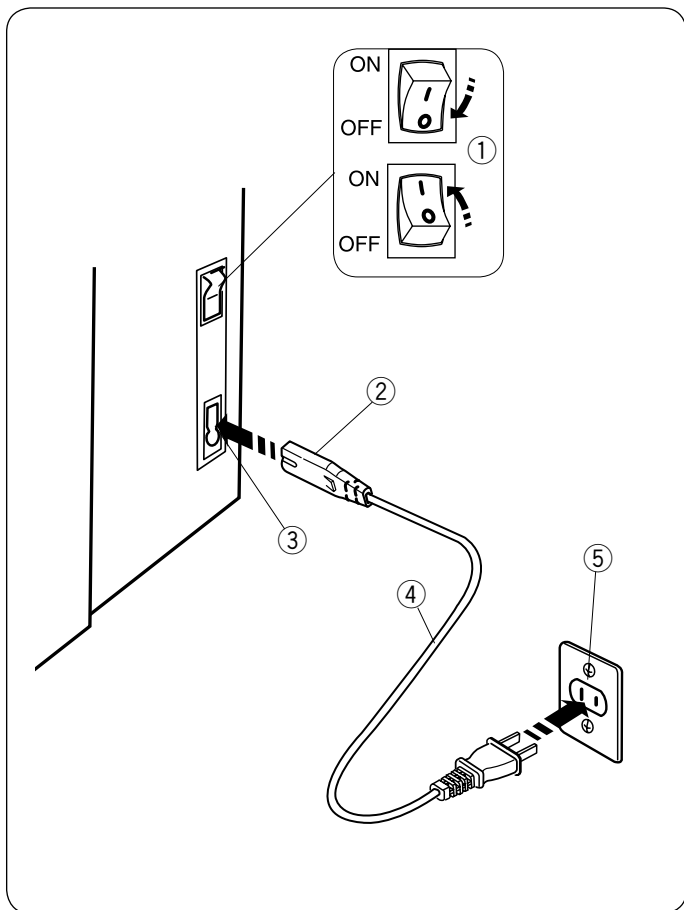

Connecting the Power Supply

- ① First make sure the power switch ① is off.
- ② Insert the machine plug ② of the power supply cord into the power inlet ③.
- ③ Insert the power supply plug ④ into the wall outlet ⑤, and turn the power switch ① on.
 - ① Power switch
 - ② Machine plug
 - ③ Power inlet
 - ④ Power supply plug
 - ⑤ Wall outlet

NOTE:

Make sure to use the power cable that came with the machine.

If you turn off the power switch, wait for 5 seconds before turning it on again.



WARNING:

While in operation, always keep your eyes on the sewing area, and do not touch any moving parts such as the thread take-up lever, handwheel or needle.

Always turn off the power switch and unplug the machine from the power supply:

- when leaving the machine unattended.
- when attaching or removing parts.
- when cleaning the machine.

For the U.S.A. and Canada only

Polarized plug (one blade wider than the other):

To reduce the risk of electric shock, this plug is intended to fit in a polarized outlet only one way. If it does not fit fully in the outlet, reverse the plug. If it still does not fit, contact a qualified electrician to install the proper outlet. Do not modify the plug in any way.

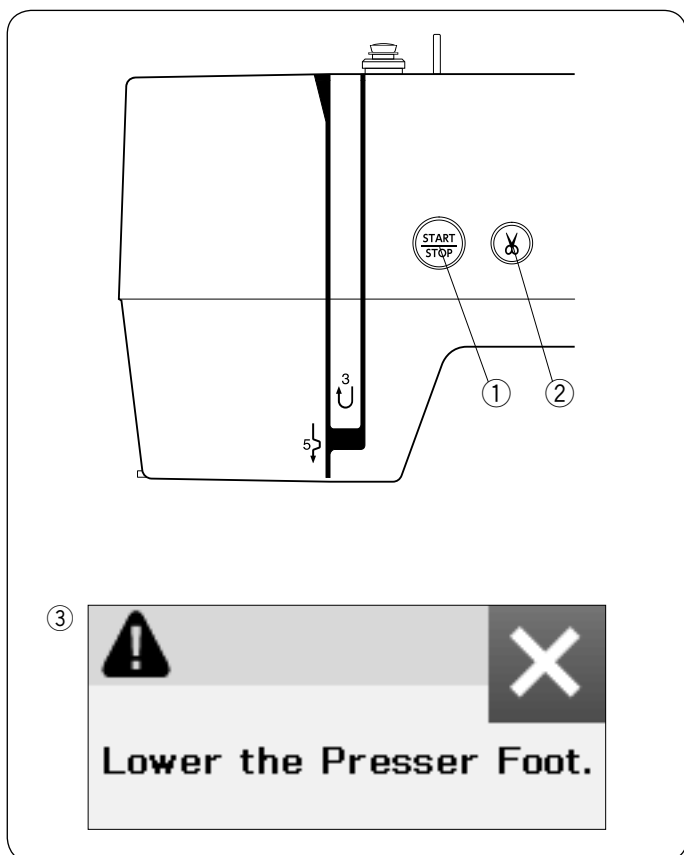

Machine Operating Buttons

① Start/stop button

Press this button to start or stop the machine. The button turns red when the machine is running, and green when it stops.

② Thread cutter button

Press this button when you finish sewing to trim the threads. The needle bar automatically rise after trimming the threads.

NOTE:

If you press the start/stop button without lowering the presser foot, the warning message ③ appears on the visual touch screen.

Lower the presser foot and press the start/stop button.

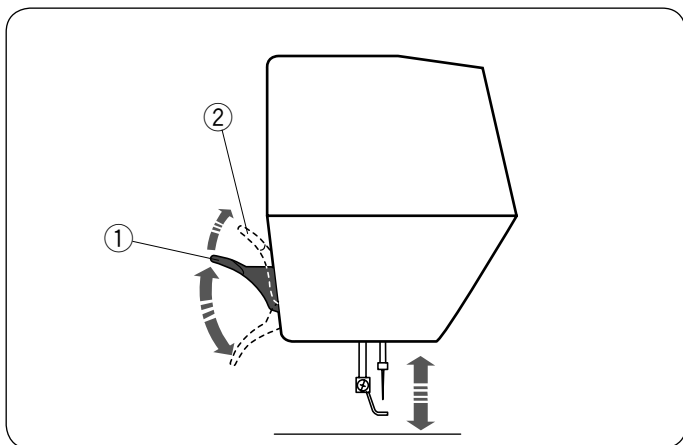

Raising and Lowering the Presser Foot

You can raise and lower the presser foot with the presser foot lifter.

- ① Presser foot lifter
- ② Extra lifted position

You can raise the presser foot about 7 mm (1/4") higher than the normal up position by exerting more pressure when lifting the presser foot lifter.

NOTE:

Do not turn the hand wheel when the presser foot is in the extra lifted position.

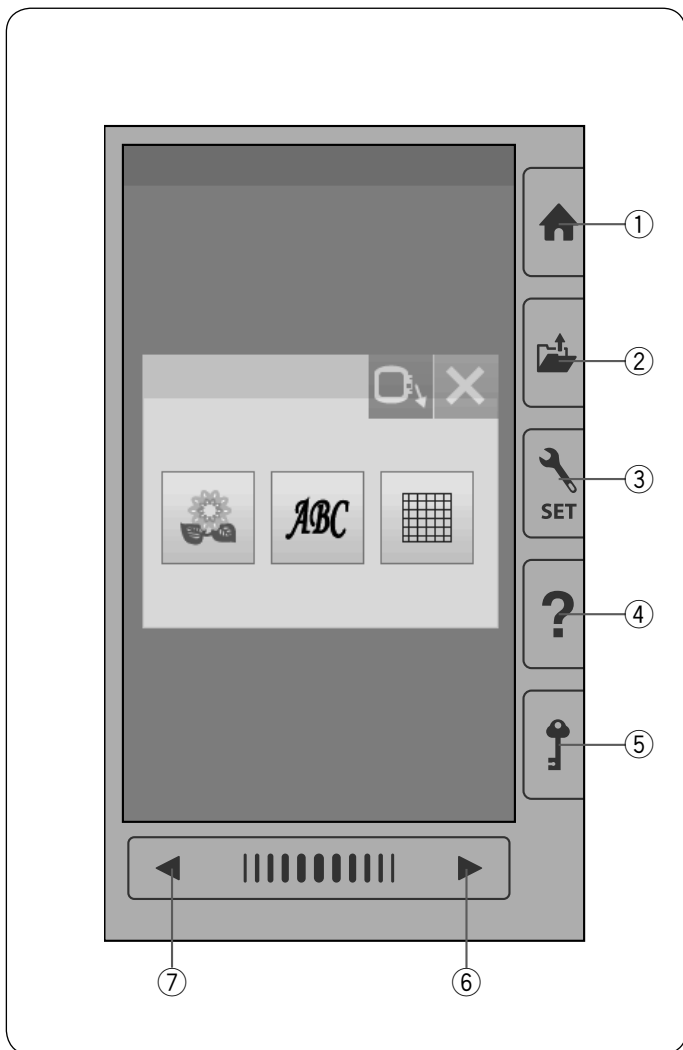

Common Keys

! CAUTION:

Do not press the visual touch screen with hard or sharp objects like pencils, screwdrivers or the like. Use the touch panel stylus included in the standard accessories.

① Home key

Press this key to enter the category selection.

② Open file key

Press this key and the open file window will open. You can open embroidery designs saved in the machine's internal memory or on a USB flash drive.

③ Set mode key

Press this key to enter the setting mode. You can customize the machine settings to your preference. The machine settings for common settings, embroidery and language selection are available in this mode.

④ Help key

Press this key to view the step-by-step visual guide about the essential operations.

⑤ Lockout key

Press this key to lockout the machine when threading the machine, replacing the accessories etc.

To reduce the risk of injury, all the buttons and keys are deactivated.

To unlock the machine, press the lockout key ⑤ again.

⑥ Next page key

To view the next page, press the next page key.

⑦ Previous page key

To view the previous page, press the previous page key.

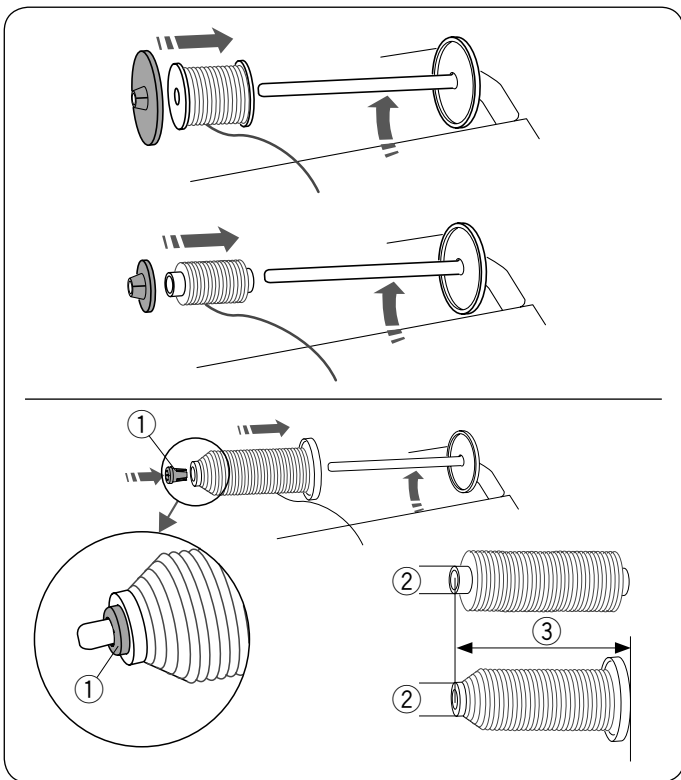

Setting the Spool of Thread

Lift up the spool pin. Place the spool of thread on the spool pin.

Attach the large spool holder, and press it firmly against the spool of thread.

NOTE:

Use the small spool holder to hold narrow or small spools of thread.

Use the spool holder (special) to hold the specific size of the spool of threads as shown.

The sizes of the spools of thread are as follows; The hole diameter of the spool has a range of 3/8" to 7/16" (9.5 to 10.5 mm), and the spool length has a range of 2 3/4" to 3" (70 to 75 mm).

- ① Spool holder (special)
- ② Hole diameter (3/8" to 7/16")
- ③ Spool length (2 3/4" to 3")

Firmly insert the spool holder (special) into the hole and hold the spool as illustrated.

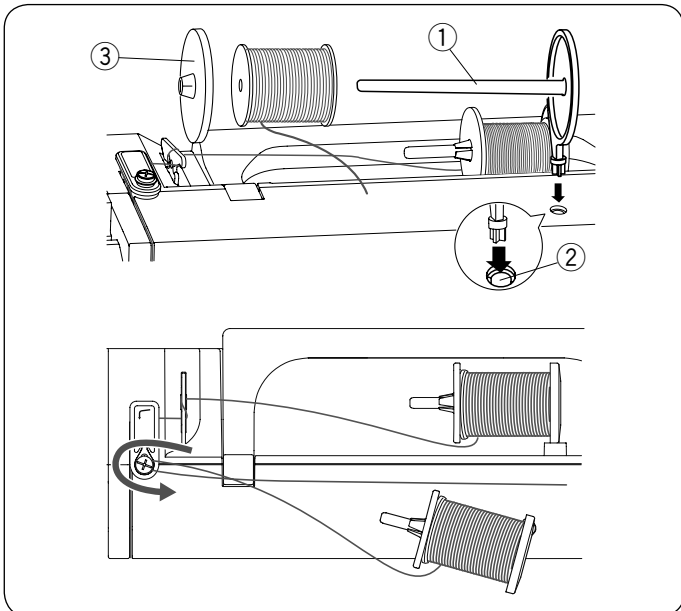

Extra spool pin

Use the extra spool pin when you need to wind a bobbin without unthreading the machine while working on a sewing project.

Insert the extra spool pin into the hole as shown.

Place a spool of thread on the extra spool pin and fix the spool with the spool holder.

- ① Extra spool pin
- ② Hole for extra spool pin
- ③ Large spool holder

Draw the thread to the left and forward around the bobbin winder thread guide as shown.

Firmly pull the thread to the right.

Follow the procedure from [2] to [8] of page 9 to wind the bobbin.

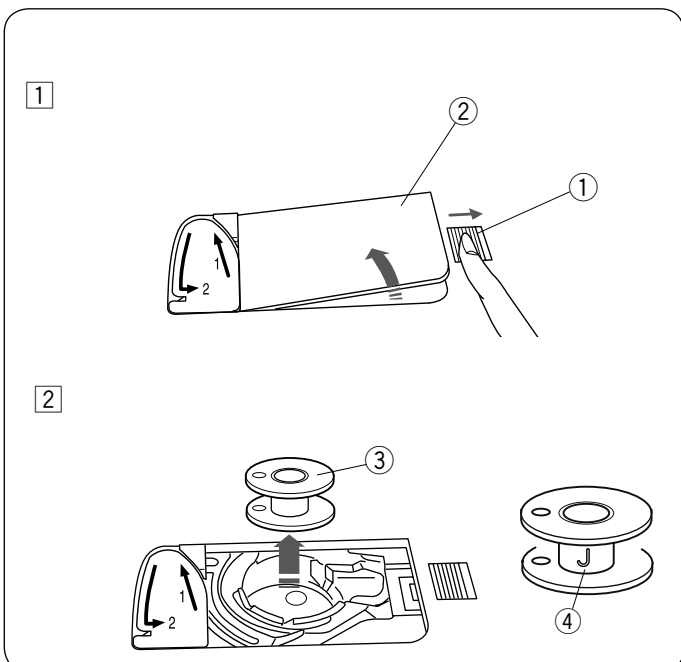

Winding the Bobbin

Removing the bobbin

CAUTION:

Press the lockout key or turn the power switch off.

- ① Slide the hook cover release button ① to the right, and remove the hook cover plate ②.

- ① Hook cover release button
- ② Hook cover plate

- ② Remove the bobbin ③ from the bobbin holder.

- ③ Bobbin

NOTE:

Use the plastic bobbins for horizontal hook marked with a "J" ④. Using other bobbins, such as pre-wound paper bobbins, may cause stitching problems and/or damage to the bobbin holder.

Winding the bobbin

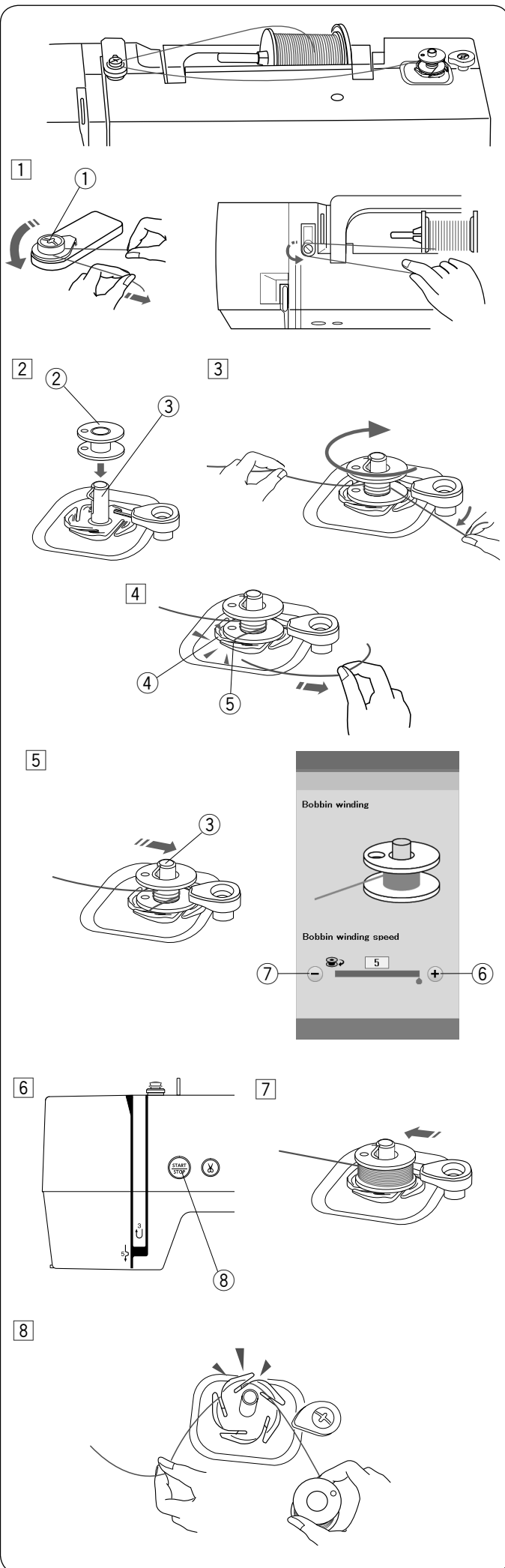

- 1 Draw the thread from the spool.
Guide the thread around the bobbin winder thread guide.
① Bobbin winder thread guide
 - 2 Put the bobbin on the bobbin winder spindle.
② Bobbin
③ Bobbin winder spindle
 - 3 Pass the thread to the bobbin.
Hold the thread with both hands and wind it around the bobbin clockwise several times.
 - 4 Insert the thread into one of the slits ⑤ of the flange plate ④ and pull the thread to cut.
④ Flange plate
⑤ Slit
 - 5 Push the bobbin winder spindle ③ to the right.
The visual touch screen will show the bobbin winding sign.
If you wish to wind the bobbin thread more quickly or slowly, you can adjust the maximum bobbin winding speed by pressing the “+” key ⑥ or “-” key ⑦.
- NOTE:**
Do not move the bobbin winder spindle while the machine is running.
- 6 Press the start/stop button ⑧.
⑧ Start/stop button
When the bobbin is fully wound, it will stop spinning automatically.
Press the start/stop button ⑧ to stop the machine.
 - 7 Return the bobbin winder to its original position by moving the spindle to the left.
 - 8 Remove the bobbin.
Insert the thread into one of the slits of the flange plate and pull the thread to cut.

NOTE:
For safety purposes, the machine will automatically stop 1.5 minutes after starting bobbin winding.

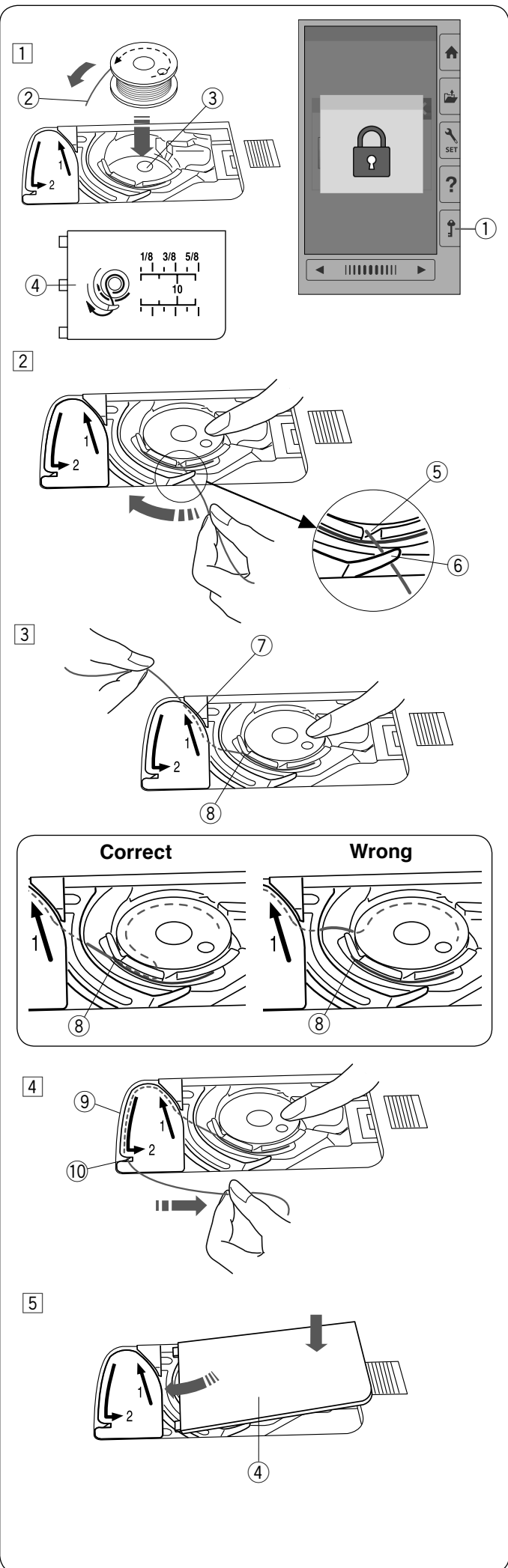

Inserting the bobbin

- 1 Press the lockout key.
Place a bobbin in the bobbin holder with the thread running off counterclockwise as shown on the hook cover plate.
 - 1 Lockout key
 - 2 End of thread
 - 3 Bobbin holder
 - 4 Hook cover plate

- 2 Hold the bobbin with your fingertip so it does not rotate.
Guide the thread into the front notch of the bobbin holder.
Pull the thread to the left to pass it under the guide.
 - 5 Front notch
 - 6 Guide

- 3 Draw the thread to the left to pass it into the guide path marked "1".
Make sure that the thread comes out from the side notch of the bobbin holder.
 - 7 Guide path 1
 - 8 Side notch

NOTE:

If the thread does not come out from the side notch, rethread from step 1.

- 4 Continue to draw the thread along the guide path marked "2" and pull the thread to the right through the slit. The thread will be cut to a proper length and held in place.
 - 9 Guide path 2
 - 10 Slit (Thread cutter)

- 5 Set the left edge of the hook cover plate into opening.
Push down the hook cover plate to fit in place.

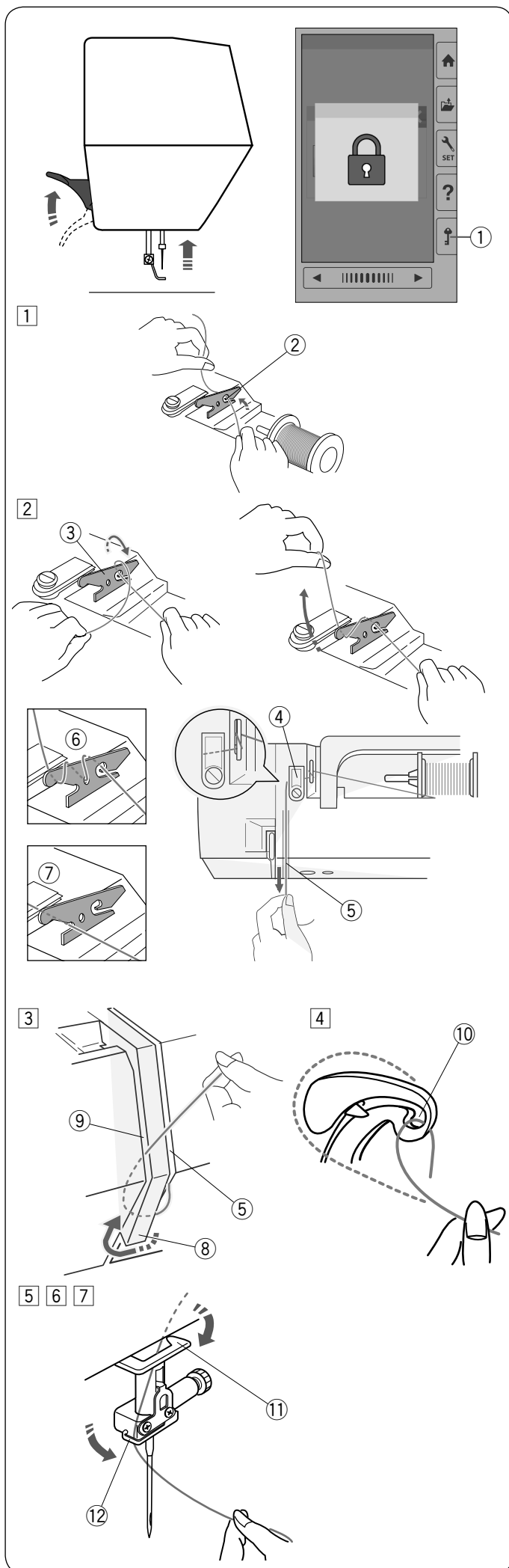

Threading the Machine

Raise the presser foot lifter.

Press the lockout key to lockout the machine.

Turn the handwheel toward you to raise the needle at its highest position.

- ① Lockout key

Pass the thread in order from ① to ⑦.

- ① Pull the thread from the spool.
Hold the thread with both hands and pass the thread into the slit of the pre-tension thread guide.
 - ② Slit
- ② Wind the thread around the pre-tension thread guide once as shown.
Draw the thread around the corner of the upper thread guide.
Firmly pull the thread toward you along the right channel until the thread snaps.
 - ③ Pre-tension thread guide
 - ④ Upper thread guide
 - ⑤ Right channel

NOTE:

If the thread slips out of the pre-tension thread guide while sewing, wind the thread through the hole as shown ⑥ when threading through the pre-tension thread guide.

NOTE:

If the thread coming out from the needle eye is too short after auto thread cutting and skipped stitch occurs, draw the thread through the pre-tension thread guide as shown ⑦.

- ③ Draw the thread down along the right channel and around the bottom of the thread guide plate.
Pull the thread up along the left channel.
 - ⑤ Right channel
 - ⑧ Thread guide plate
 - ⑨ Left channel
- ④ While holding the thread at the spool, firmly draw the thread up and to the back of the take-up lever. Draw the thread forward to draw it into the eye of the take-up lever.
 - ⑩ Eye of the take-up lever
- ⑤ Then pull the thread down along the left channel and through the lower thread guide.
 - ⑪ Lower thread guide
- ⑥ Slide the thread behind the needle bar thread guide on the left.
 - ⑫ Needle bar thread guide
- ⑦ Thread the needle with the needle threader (refer to the next page).

Built-in Needle Threader

NOTE:

The needle threader can be used with a #11 to #14 needle.

Thread size 50 to 90 is recommended.

Do not use thread size 30 or thicker.

- 1 Press the lockout key to lock the machine.
Lower the presser foot.
Turn the handwheel toward you to until the needle thread sign ② appears on the right upper corner of the lockout window.
 - ① Lockout key
 - ② Needle threader sign
- 2 Pull down the needle threader knob as far as it will go.
The threader hook comes out through the needle eye from behind.
 - ③ Threader knob
 - ④ Threader hook
- 3 Draw the thread from left to right, under the left guide, threader hook and right guide.
Draw the thread around the right guide toward you.
 - ⑤ Left guide
 - ⑥ Right guide
- 4 Raise the threader slowly so a loop of the thread is pulled up through the needle eye.
 - ⑦ Threader loop
- 5 Remove the thread end through the needle eye to the rear.

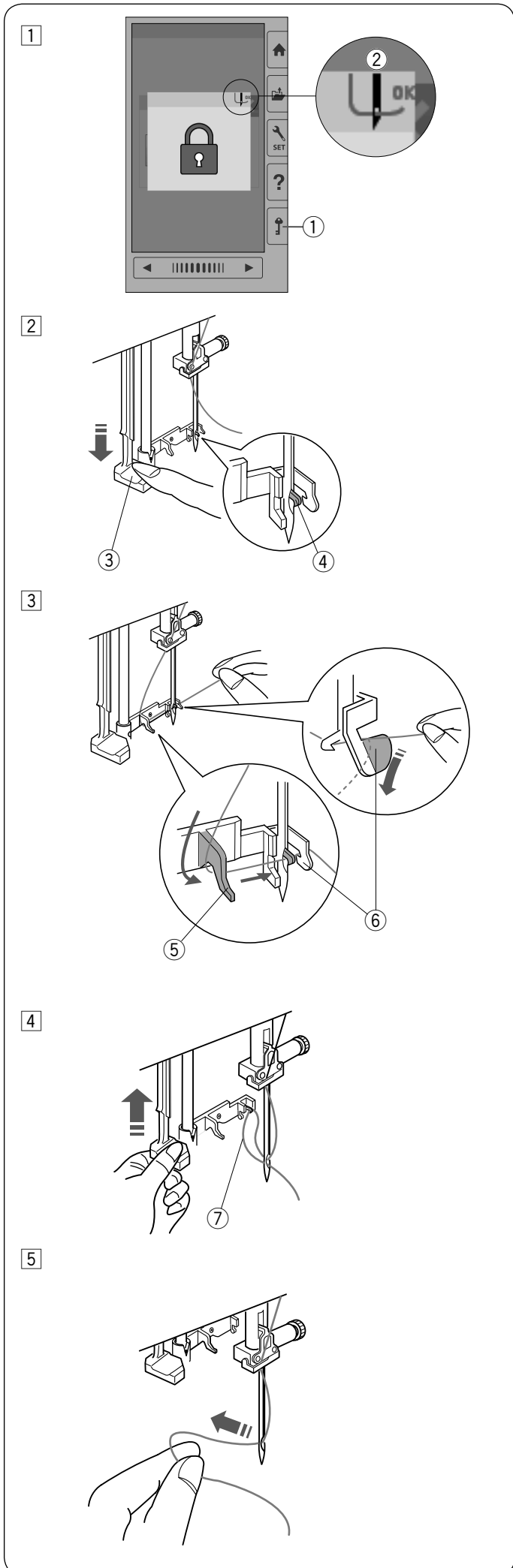

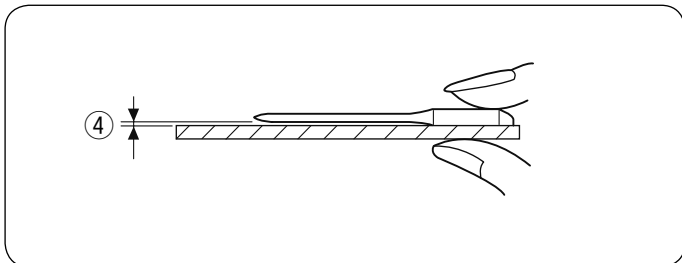
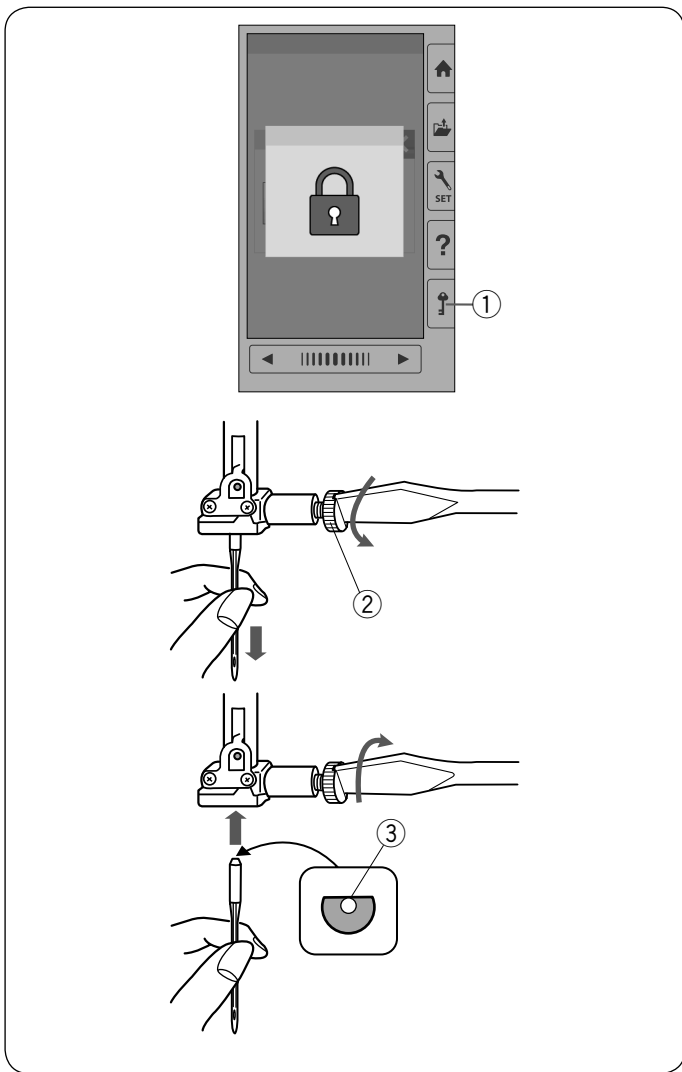

Replacing Needles

CAUTION:

Always make sure to press the lockout key to lockout the machine or turn the power switch off before replacing the needle.

A loose needle or a loose screw may cause machine malfunction or needle to break.

Raise the needle by turning the handwheel.

Turn the power switch off or press the lockout key.

① Lockout key

Loosen the needle clamp screw by turning it counterclockwise.

Remove the needle from the clamp.

② Needle clamp screw

Insert a new needle into the needle clamp with the flat side of the needle to the rear.

③ Flat side

When inserting the needle into the needle clamp, push it up against the stopper pin and tighten the needle clamp screw firmly with a screwdriver.

To check needle straightness, place the flat side of the needle onto something flat (a needle plate, glass etc.). The gap between the needle and the flat surface should be consistent.

④ Gap

Never use a blunt needle.

NOTE:

Use size 11 blue tipped needle for fine fabrics.

For medium to heavy weight fabrics, use size 14 needles.

Fabric and Needle Chart

Fabric	Thread	Needle
Fine	Embroidery thread	Blue tip needle or
Medium		EL x 705 Size 12/80
Heavy weight		Universal needle #14 or EL x 705 Size 14/90

Janome bobbin thread for embroidery is recommended for bobbin.

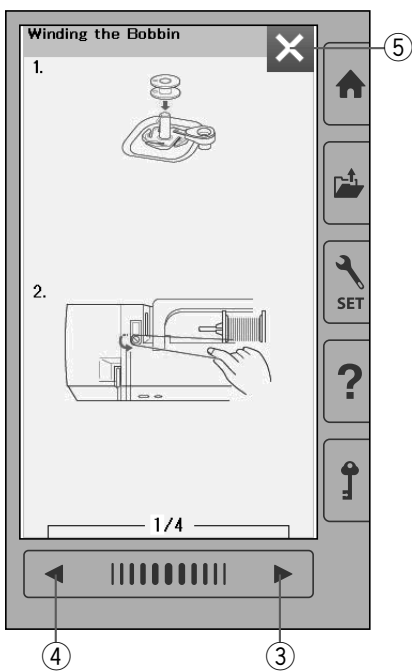
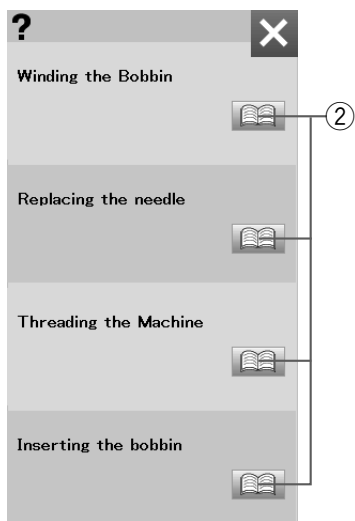
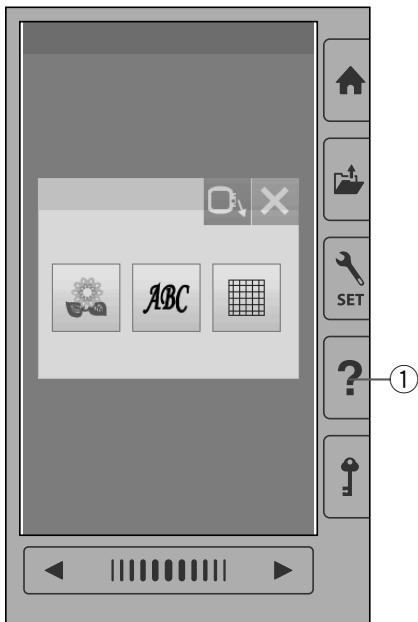

On-screen Help

Press the help key to open the help menu.

You can view instructions on 4 topics of essential operations of the machine.

Select the help topic by pressing the book icon and the step-by-step instruction will open.

- ① Help key
- ② Book icon

To view the next page, press the next page key.

To view the previous page, press the previous page key.

Press the X key to close the current window.

- ③ Next page key
- ④ Previous page key
- ⑤ X key

1

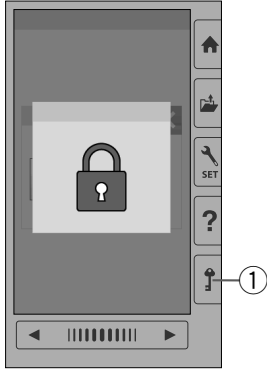

2

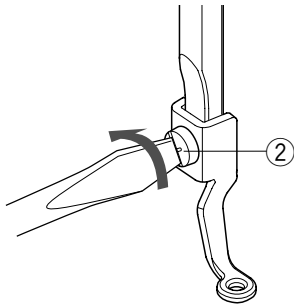

1 2

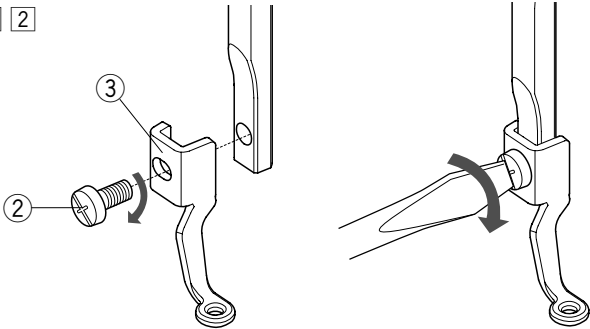

Removing and Attaching the Embroidery Foot

Remove the embroidery foot when removing the needle plate for the maintenance, etc.



CAUTION:

Always make sure to press the lockout key to lockout the machine or turn the power switch off before removing or attaching the embroidery foot.

To remove:

- 1 Turn the power switch off or press the lockout key. Raise the needle by turning the handwheel toward you.
 - 1 Lockout key
- 2 Loosen the setscrew with the screwdriver and remove the embroidery foot.
 - 2 Setscrew

To attach:

- 1 Attach the embroidery foot to the presser bar from the left side.
 - 2 Setscrew
 - 3 Embroidery foot
- 2 Tighten the setscrew securely with the screwdriver.

Bobbin Holder for Embroidery (high tension)

Replace the standard bobbin holder with the bobbin holder for embroidery (high tension) when using bobbin threads other than Janome bobbin thread for embroidery.

⚠ CAUTION:

Always make sure to press the lockout key to lockout the machine or turn the power switch off before attaching the bobbin holder.

NOTE:

- The special bobbin holder for embroidery (high tension) is marked with a yellow dot for identification.
 - ① Yellow dot
- The special bobbin holder for embroidery (high tension) is already installed in the machine for some models.

- ① Remove the needle, embroidery foot and needle plate (refer to the pages 13, 15 and 58).
Take out the standard bobbin holder.
 - ② Standard bobbin holder
- ② Insert the special bobbin holder into the hook race. Make sure to match the knob of the bobbin holder with the stopper on the machine. Attach the needle plate, presser foot and needle.
 - ③ Knob
 - ④ Stopper
 - ⑤ Special bobbin holder for embroidery (high tension)

NOTE:

Use the standard bobbin holder when sewing quilting designs that use the same thread for the bobbin as the needle thread.

Embroidery Hoops

- ① Embroidery hoop SQ14b

A square embroidery hoop with a 14 cm (5.5") square embroidery area.

- ② Embroidery hoop RE20b

An extra large embroidery hoop with a 14 cm by 20 cm (5.5" by 7.9") embroidery area.

- ③ Embroidery hoop SQ20b

A square embroidery hoop with a 20 cm (7.9") square embroidery area.

- ④ Clamp (RE20b and SQ20b)

A clamp for holding the fabric to the embroidery hoops RE20b and SQ20b.

* The embroidery hoops supplied with your machine vary depending on your model.

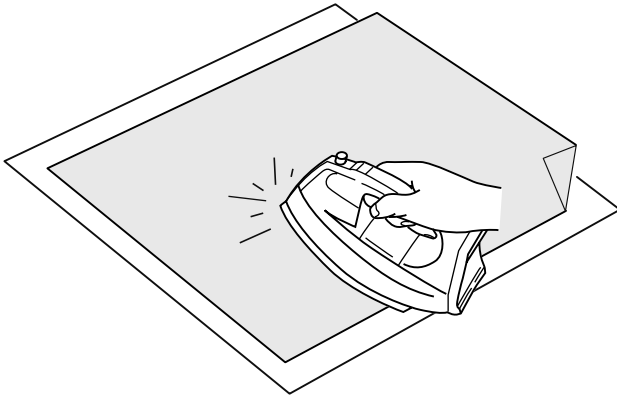

Stabilizers

To create the best quality embroidery, it is important to use stabilizers.

How to use:

Attach the stabilizer to the wrong side of the fabric. You may need to use more than one layer.

For firm fabrics, you may place a thin sheet of paper under the fabric.

The non-adhesive type should be used when embroidering fabric which cannot be ironed or for sections which are difficult to iron.

Cut the stabilizer larger than the embroidery hoop and set it on the hoop so that the entire piece is fastened to the hoop to prevent any looseness in the fabric.

Attaching the stabilizer

Place the wrong side of fabric and the glossy side of the stabilizer together. Fold up a corner of the stabilizer and fuse it with an iron.

NOTE:

Fold up a corner of the stabilizer, to make it easier to peel off the excess stabilizer after stitching. Ironing temperatures vary depending on the kind of adhesive stabilizer you are using.

Types of the stabilizers

Type	Usage	Property
Tear-away	Stable woven fabrics	Made from a fiber that will tear easily.
Iron-on	Knits and all kinds of unstable fabrics	Adhesive type fusible with an iron.
Cut-away	Knits and all kinds of unstable fabrics	Non-woven fabric that does not tear.
Water soluble	Cutwork or lace embroidery Right side of looped fabrics such as towels to avoid loops coming through the embroidery	A thin film that will dissolve in water.
Heat-away	Cutwork or lace embroidery	A thin film that will melt away with heat.

NOTE:

Sticky type stabilizers can be used only for securing a small piece of fabric or work that cannot be secured in the hoop, or for securing velvet and other napped fabric that would be permanently marked by the hoop. Clean the bobbin holder after stitching as glue can get stuck on it.

Setting the Fabric in an Embroidery Hoop

- 1 Prepare a fabric and attach a stabilizer to the wrong side of the fabric.
The fabric and stabilizer should be larger than the hoop size.
Draw the centerlines on the fabric with tailor's chalk.

- ① Fabric
- ② Centerlines

- 2 Lay the inner hoop and template on the fabric, matching the centerlines of the fabric with the template.

- ③ Inner hoop
- ④ Template

- 3 Loosen the hoop tightening screw on the outer hoop.
Place the inner hoop and fabric on the outer hoop.

- ⑤ Hoop tightening screw
- ⑥ Outer hoop

- 4 Push the inner hoop and fabric into the outer hoop.
Tighten the screw on the outer hoop to stretch the fabric. Make sure that the fabric is stretched tightly in the hoop.
Remove the template.

- 5 Clamp the fabric to the hoop with the clamps when using hoop SQ20b or RE20b.

- ⑦ Clamp

NOTE:

Thick layers of fabric and stabilizer may cause skipped stitches, or broken threads and needles. Avoid sewing on the layers thicker than 3 mm (1/8").

Attaching the Embroidery Hoop to the Machine

To attach:

- 1 Raise the presser foot.
Turn the handwheel toward you to raise the needle at its highest position. Turn the power switch on. If the carriage is not at the home position, the caution message appears to move the carriage to the home position. Press OK key to move the carriage to the home position.
 - 1 OK key
- Select or edit the desired pattern and press OK key. Ready to Sew screen appears and the carriage moves to the start position. Press the lockout key to lockout the machine.
 - 2 Lockout key

- 2 Place the prepared hoop on the machine. Position the hoop by aligning the notches of the hoop with the carriage pins.
 - 3 Notch
 - 4 Carriage pin
 - 5 Carriage
 - 6 Lever

- 3 Shift the lever in the direction of the arrow.
 - 6 Lever
- 4 Attach the hoop by pushing it against the carriage pins.
- 5 Push the lever in the direction of arrow to lock the hoop in place.

To remove:

- 1 Raise the presser foot. Turn the handwheel toward you to raise the needle at its highest position. Press the lockout key to lock the machine.
- 2 Shift the lever in the direction of the arrow and remove the hoop.
 - 6 Lever

CAUTION:

- Be careful not to place the excess of fabric between the carriage and machine body 7.
- Never try to move the carriage by hand or touch the carriage while it is moving.

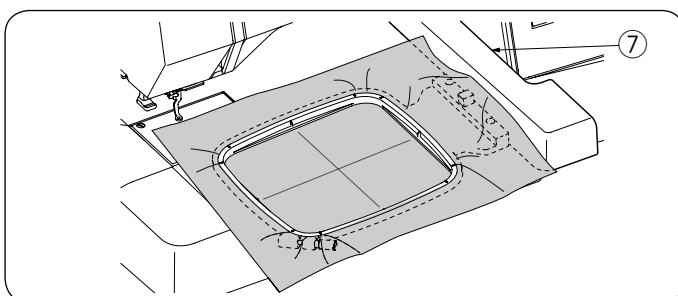
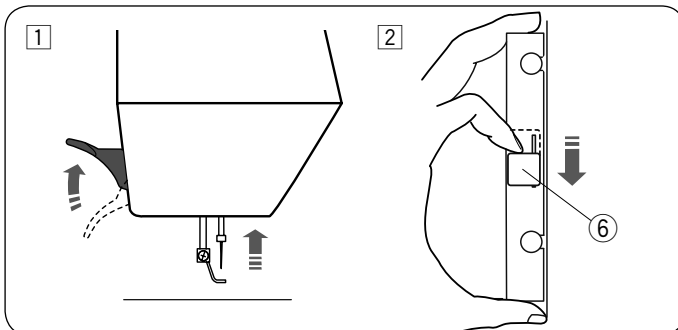
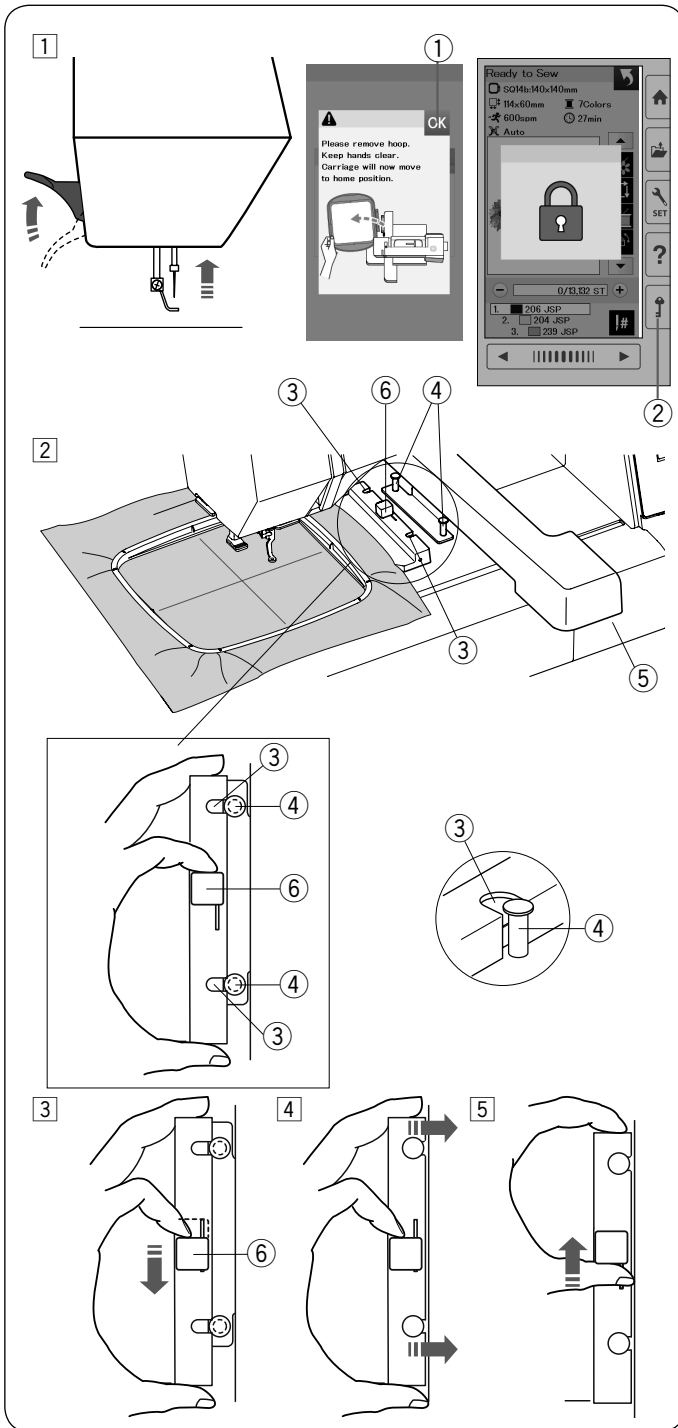

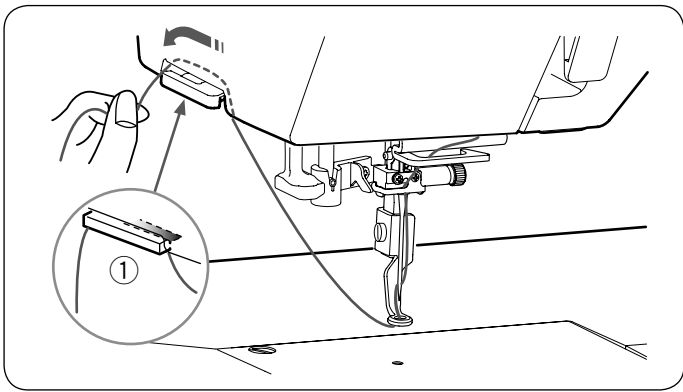

Thread Holder

To avoid sewing over a tail of the needle thread, place the thread end on the thread holder. Pass the needle thread through the hole in the embroidery foot and draw it up to the thread holder. Hang the thread on the thread holder from front to back.

- ① Thread holder

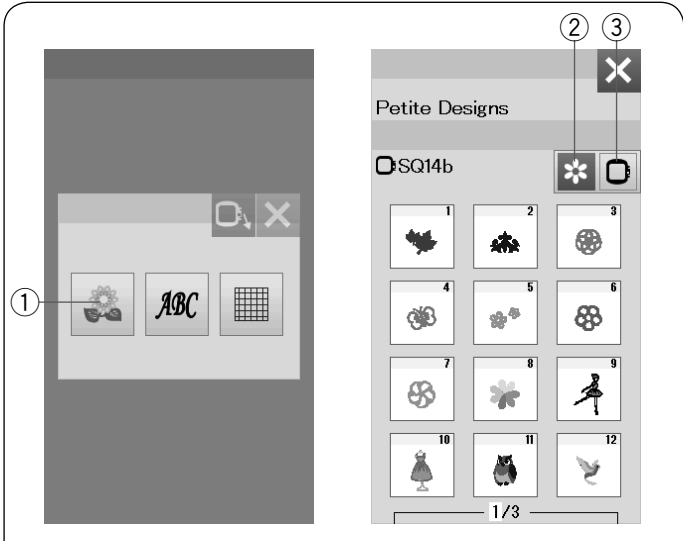

Selecting Built-in Embroidery Designs

Press the built-in design key and the first page of the design list of Petite Designs will open.

- ① Built-in design key

Press the design category key to browse the design list by design category, or press the hoop selection key to browse the designs by hoop size.

- ② Design category key
- ③ Hoop selection key



Design category

Press the design category key ② to show the design lists by category.

Press the previous/next page keys to browse the design lists.

- ④ Previous page key
- ⑤ Next page key

Page 1 of 3

- Petite Designs
- Favorite Designs
- Border Designs
- Geometric Designs

Page 2 of 3

- Pantry Designs
- Word Style Designs
- Flourish Alphabet
- Quilting Designs

Page 3 of 3

- Bracelet Designs
- Celebration Designs
- Calibration Pattern

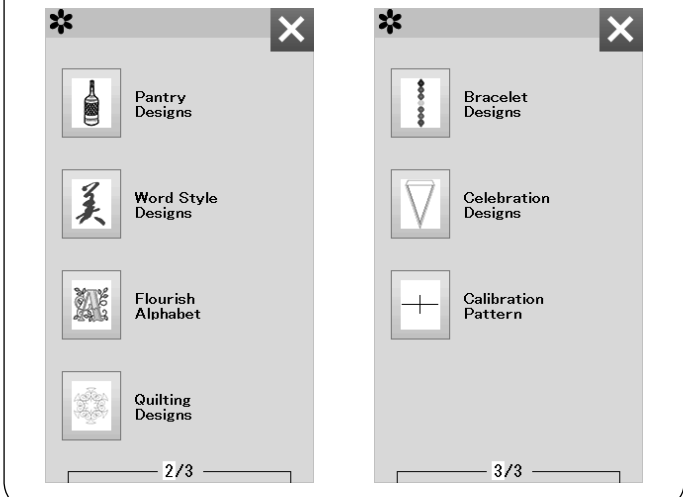

Press the desired category to select and the pattern selection window will open.

Browse the pattern list with the previous/next page keys, and select the desired pattern by pressing the pattern icon key.

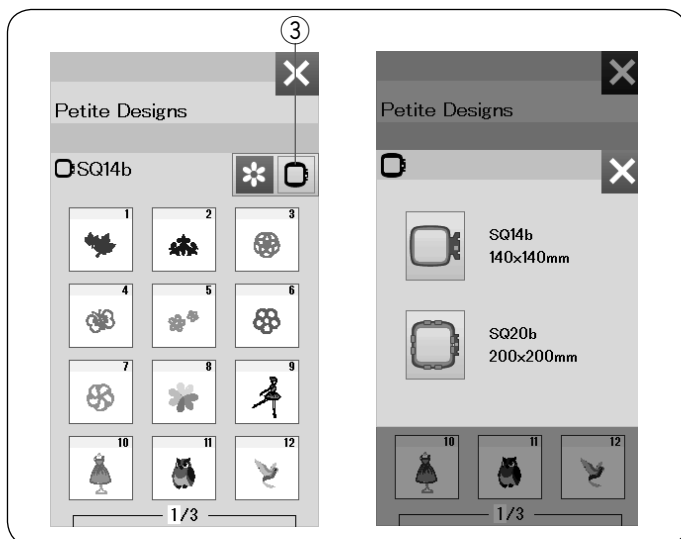

Selecting the design by hoop size

Press the hoop selection key ③ and the hoop selection window will open. Select a hoop size the same or smaller than the one you will attach.

Browse the design list with the previous/next page keys, and select the desired pattern by pressing the pattern icon key.

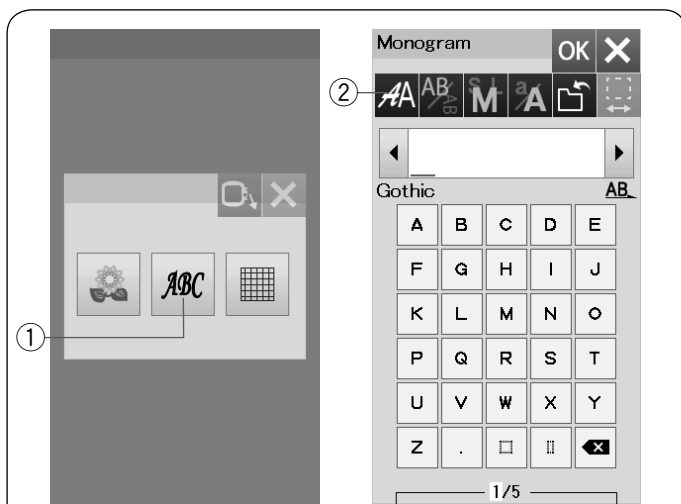

Monogramming

Press the monogram key and the monogram window will open.

Press the font selection key to open the font selection window.

- ① Monogram key
- ② Font selection key

You can select one of the 10 fonts for monogramming as well as 2-letter, 3-letter, border patterns and normal sew patterns.

The following fonts and patterns are available:

Page 1 of 2

- Gothic font
- Script font
- Cheltenham font
- Cyrillic 1 font
- Cyrillic 2 font
- Cyrillic 3 font

Page 2 of 2

- 2-Letter
- 3-Letter
- Border patterns
- Normal sew patterns

Press the icon key of the desired font and the monogram window will open.

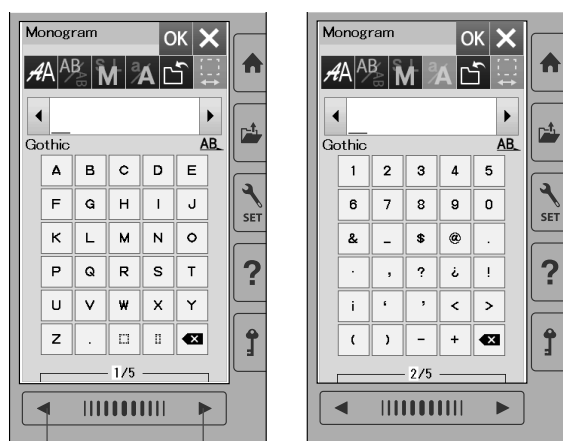
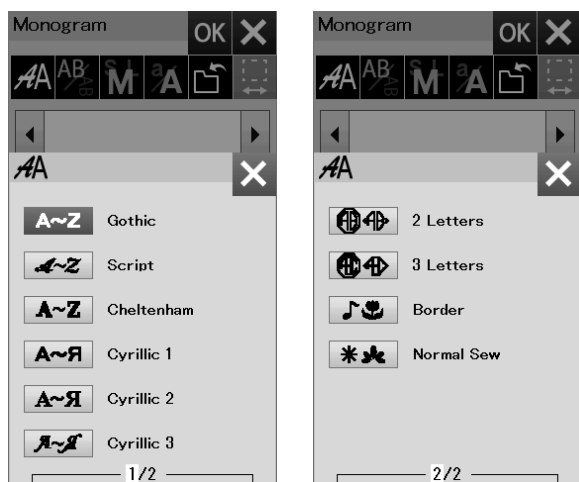

Browse pages with the previous/next page keys.

You can enter alphabet letters, numbers, symbols, Cyrillic and European letters.

- ③ Previous page key
- ④ Next page key

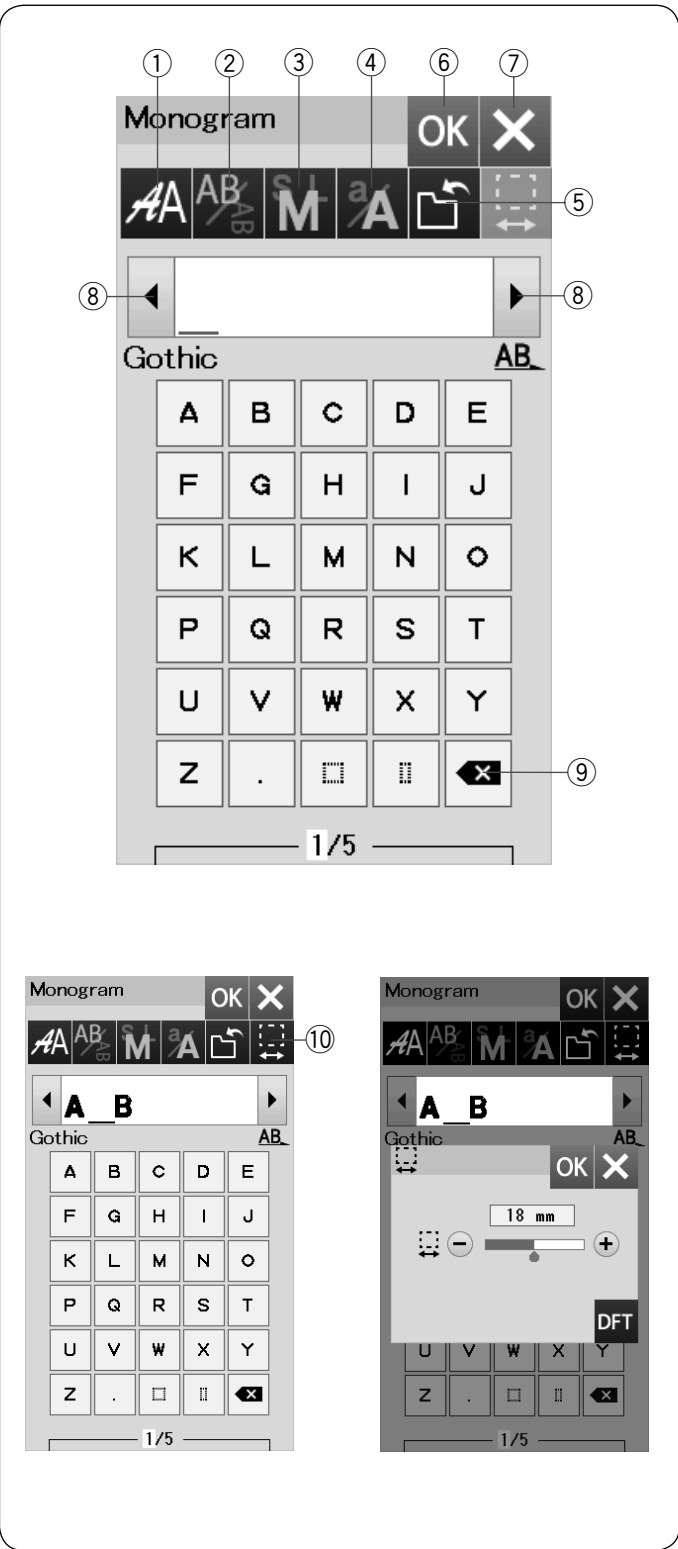

Function Keys

① Font selection key

Press this key to open the font selection window.

② Lettering orientation key

Press this key to select the horizontal or vertical orientation.

③ Letter size key

You can select the following 3 letter sizes by pressing this key.

The approximate letter sizes of upper case are as follows:

L (Large): 30 mm (1.2")

M (Medium): 20 mm (0.8")

S (Small): 10 mm (0.4")

④ Letter case key

Pressing this key changes the letter case from upper case to lower case and vice versa.

⑤ Save file key

Pressing this key opens the save file window and allows you to save the text or monogram as a file (refer to page 55).

⑥ OK key

Press this key to confirm your entry and open the Ready to Sew screen or the previous editing window.

⑦ X key

Press this key to exit the monogram entry.

⑧ Cursor key

Press these keys to move the cursor to the left or right.

⑨ Delete key

Press this key to delete the character above the cursor or the character in front of the cursor.

⑩ Space adjust key

This key is activated only when a space is entered.

If the spaces between characters look uneven, insert a blank space between characters and adjust the space width to justify.

Press this key to open the space adjustment window.

To increase the space width, press the "+" key.

To decrease the space width, press the "-" key.

NOTE:

The space width is shown only in millimeters.

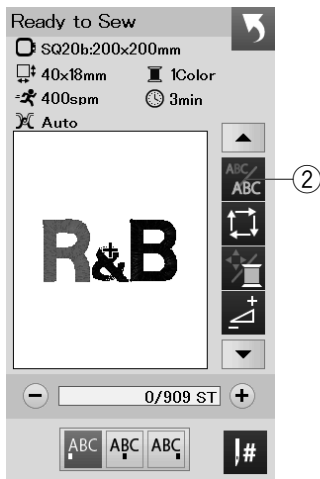
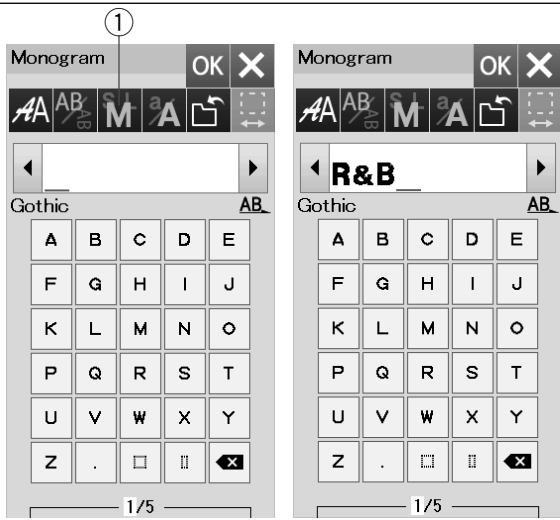

R & B

Programming a Monogram

Example: Programming “R&B” in Gothic style font.

Enter “R”, the cursor shifts to the right and “R” is automatically memorized.

Press the letter size key and select small size.

① Letter size key

Enter “&”, the cursor shifts to the right and “&” is automatically memorized.

Press the letter size key and select medium size.

Enter “B”, the cursor shifts to the right and “B” is automatically memorized.

Press the OK key.

The hoop confirmation window will appear.

The screen changes to the ready to sew window.

NOTE:

The hoop confirmation window will not be displayed if the hoop confirmation option is turned off (refer to page 51.).

Color change

You can sew a multi-colored monogram by changing the thread color of each letter if you press the color change key before sewing. The color change key changes to  when the color change function is activated.

The machine will stop automatically when each character has been sewn.

Change the thread to the next color and start sewing again.

② Color change key

Monogram placement

You can select one of 3 monogram placements: left justify, center justify and right justify.

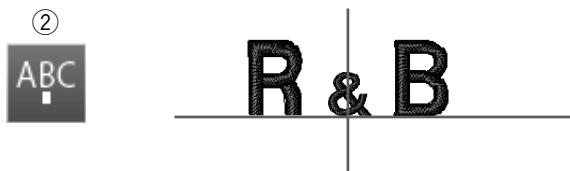
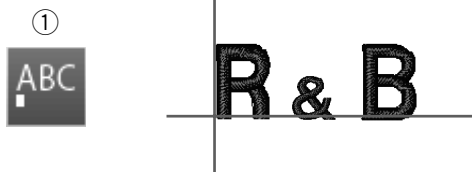

① Left Justify

Press the  key to start sewing from the left end reference line on the template.

② Center Justify

Press the  key to sew in the center of the hoop.

③ Right Justify

Press the  key to sew from the right end reference line on the template.

2-Letter monogram

Example: 2-Letter in an octagon

- 1 Press the font selection key ①.
Select 2-letter ②.

- 2 Select the octagon ③.

- 3 Enter "A" and "B".
Press the OK key and a warning message will appear.
Press the OK key and the carriage moves to the starting position.
The hoop confirmation window will appear.
Press the OK key.
The screen changes to the ready to sew window.

NOTE:

The 3-letter monogram is sewn in the same way as the 2-letter monogram.
The monogram placement for the 2-letter and 3-letter monogram is center justify.
The hoop confirmation window will not be displayed if the hoop confirmation option is turned off (refer to page 51.).

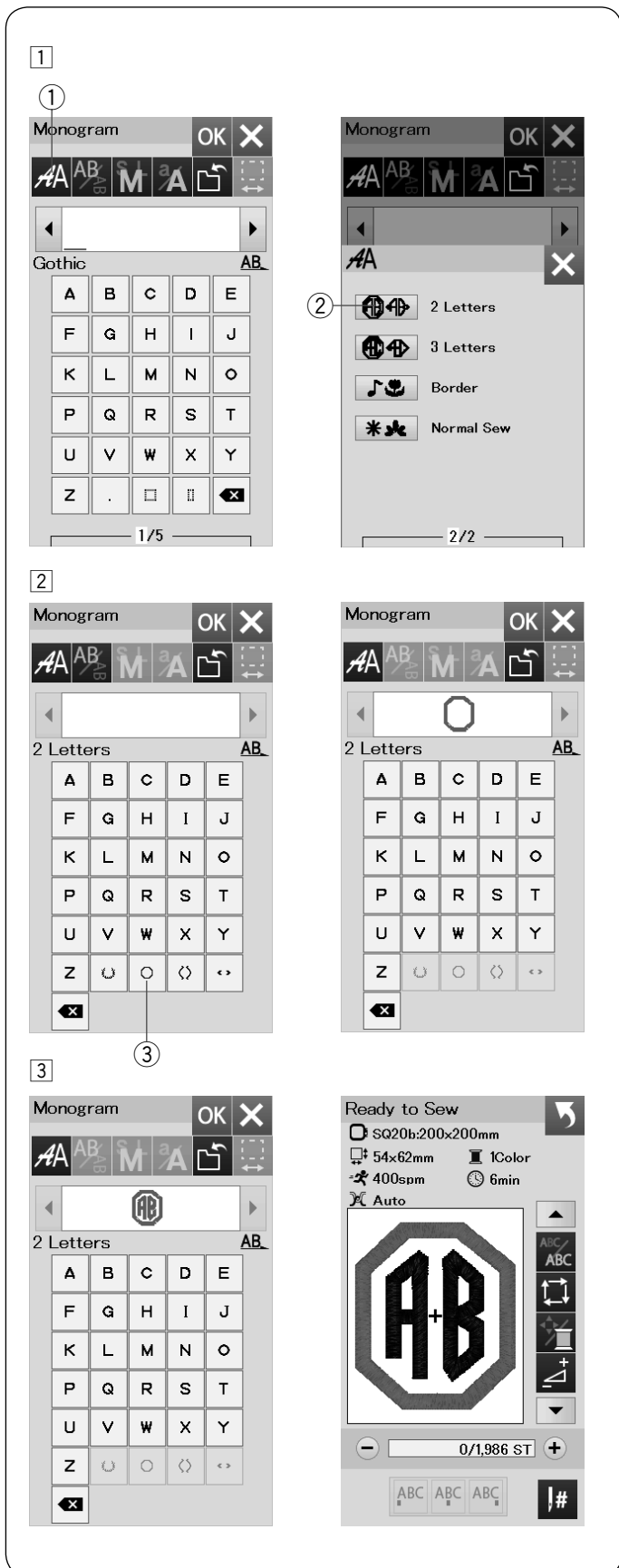

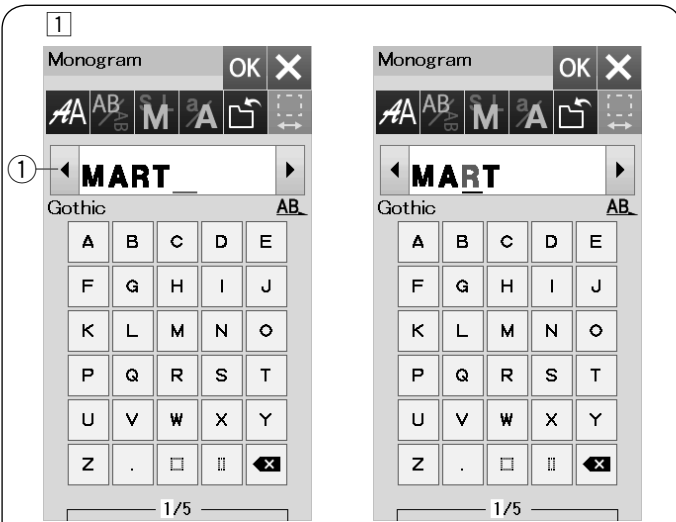

Editing a Monogram

Deleting a character: Deleting “R” from “MART”

1 Press the cursor key ① to move the cursor under “R”.

2 Press the delete key ② and letter “R” is deleted.

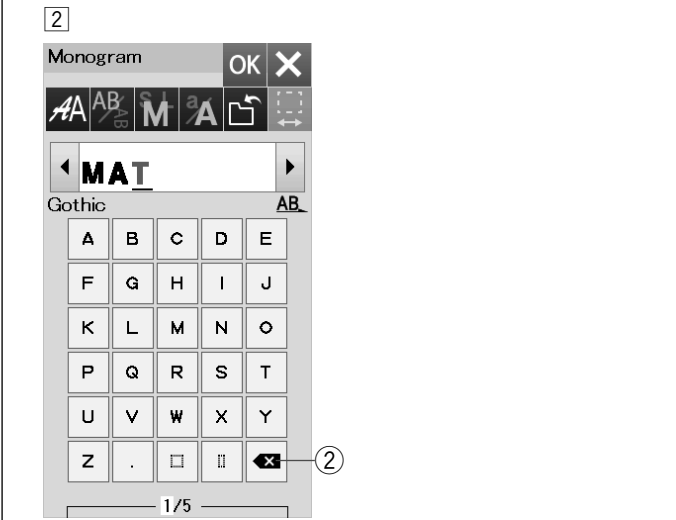

Inserting a character: Inserting “E” into “MAT”

1 Press the cursor key ① to move the cursor under “A”.

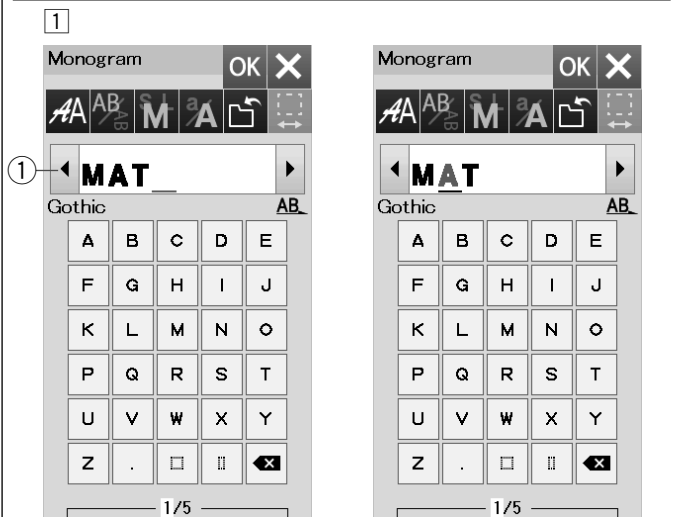

2 Enter “E”.
The letter “E” is inserted before “A”.



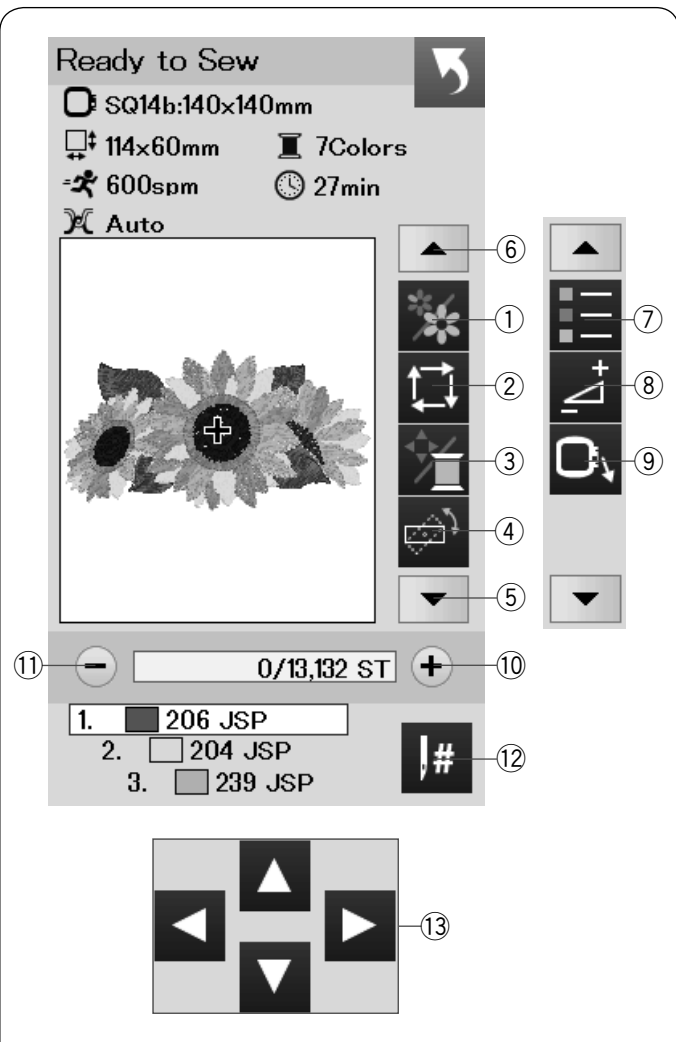

Ready to Sew Window

The ready to sew window shows embroidery function keys and information on the selected pattern. Press the down arrow key (5) or up arrow key (6) to show the next set of function keys (7 to 9).

Function keys

- ① Color section key
- ② Trace key
- ③ Thread color/Jog key
- ④ Fine position/angle adjustment key
- ⑤ Down arrow key
- ⑥ Up arrow key
- ⑦ Color list key
- ⑧ Adjust key
- ⑨ Hoop back key
- ⑩ Stitch forward key
- ⑪ Stitch back key
- ⑫ Jump key
- ⑬ Jog keys

Pattern information

The visual touch screen displays the following details:

- ① Hoop size
- ② Dimension of the design
- ③ Maximum sewing speed
- ④ Tension setting
- ⑤ Number of thread colors (layers)
- ⑥ Required sewing time
- ⑦ Preview window
- ⑧ Cross mark (current sewing point)
- ⑨ Progress bar
- ⑩ Stitch count
- ⑪ Thread color

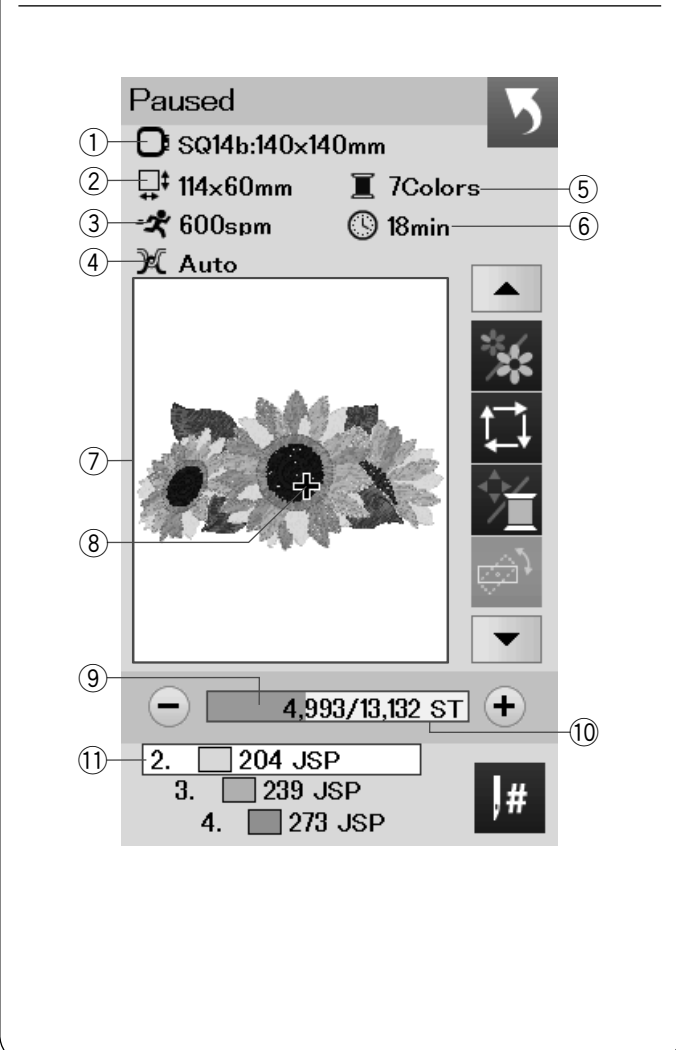

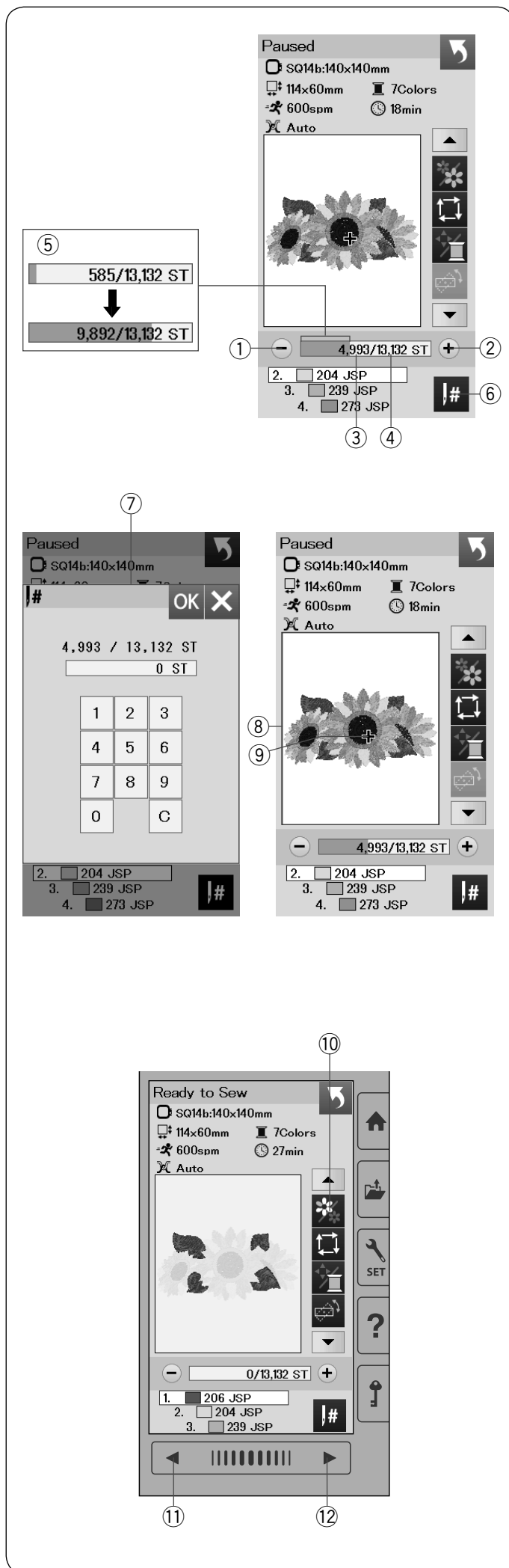

Stitch back/forward keys

Press the “-” key ① to move the hoop back to a previous sewing point.

Press the “+” key ② to move the hoop ahead.

The hoop will move one stitch each time the key is pressed. Hold down the key to travel faster and jump 10, 100 or 500 stitches at a time. The stitch count ③ and the total number of stitch count ④ are displayed in the stitch count window.

You can use these keys to move the embroidery hoop to where the thread has broken or run out.

- ① Stitch back key
- ② Stitch forward key
- ③ Stitch count
- ④ Total number of stitch count

The pale blue bar in the stitch count window is the progress bar. The progress bar ⑤ appears when the stitch count increases, and indicates the progress of the embroidery sewing project. When the project is completed, the progress bar returns to 0.

- ⑤ Progress bar

Jump key

If you want to jump to the desired sewing point directly, press the jump key ⑥ and the numeric keypad window ⑦ will open. Enter the desired stitch count number and press the OK key.

The hoop moves to the sewing point you entered.

- ⑥ Jump key
- ⑦ Numeric keypad window

Cross mark

The cross mark ⑨ in the preview window ⑧ indicates the current sewing point. Press the preview window ⑧ to hide the cross mark.

- ⑧ Preview window
- ⑨ Cross mark (Current sewing point)

Color section key

Press this key ⑩ to show the complete image of the selected design or partial image of each color section only.

To view the next color section, press the next page key ⑫.

To view the previous color section, press the previous page key ⑪.

If you want to sew the specific color section only, press the next/previous color keys until the desired section is displayed.

- ⑩ Color section key
- ⑪ Previous page key
- ⑫ Next page key

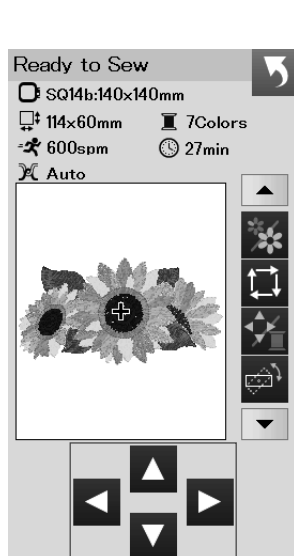
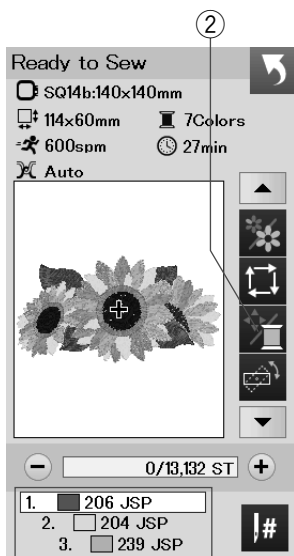
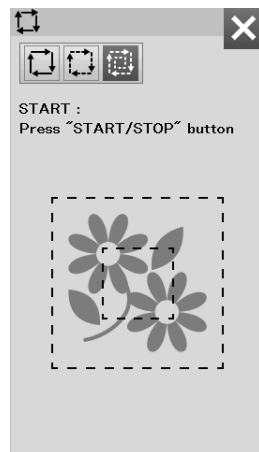
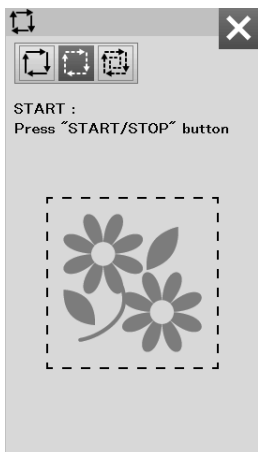
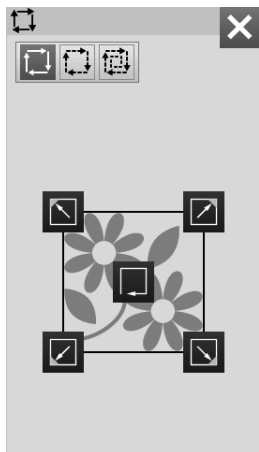
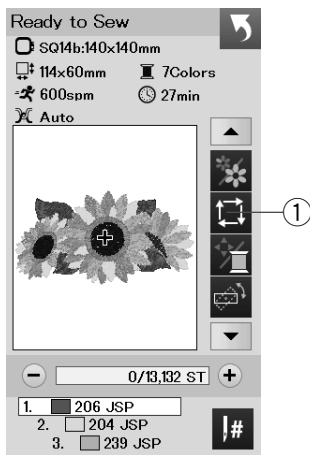

Trace key

You can check the size of the embroidery area by tracing the pattern outline without stitching or with basting stitches.



Press the trace key and the trace option window will open.

- Trace key

The following 3 options are available:

1. Trace without stitching

Press the  key to open the trace without stitching window.

Press the trace key  to start tracing or press one of the  keys to move the hoop to a corner.

2. Trace and baste (single)

Press the  key to open the trace and baste (single) window.

Lower the presser foot.

Press the start/stop button to start tracing with basting stitches.

3. Trace and baste (double)

Press the  key to open the trace and baste (double) window.

Lower the presser foot.

Press the start/stop button to start tracing with basting stitches. First, the machine bastes inside the pattern then traces the pattern outline with basting stitches.

NOTE:

The machine will baste around the embroidery area with a 5 mm allowance.

However, the allowance will be null if the pattern spreads over the maximum limit of embroidery area.

To close the tracing option window, press the X key.

Thread color/Jog key

Press the thread color/jog key to show or hide the jog keys. The thread color list of the selected design is displayed when the jog keys are hidden.

Adjust the hoop position with the jog keys so that the needle position comes right above the center of the reference lines on the fabric.

- Thread color/Jog key
- Thread color list
- Jog keys

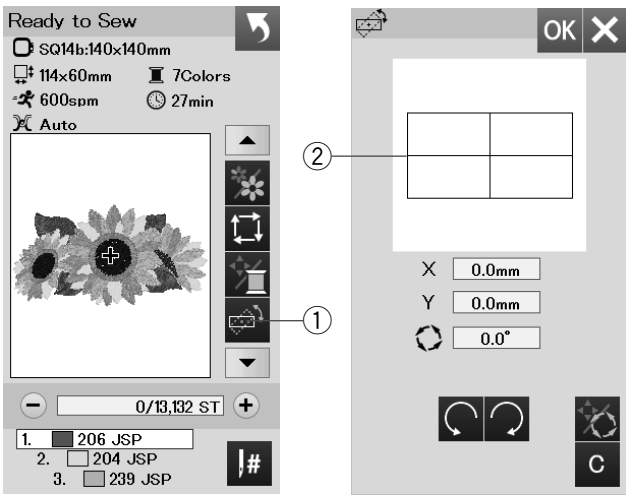

Fine position/angle adjustment key

You can make fine adjustments to the position or angle of the embroidery design without removing the embroidery hoop from the machine.

Press the fine position/angle adjustment key ①.

The original embroidery design position is previewed as a rectangle ②.

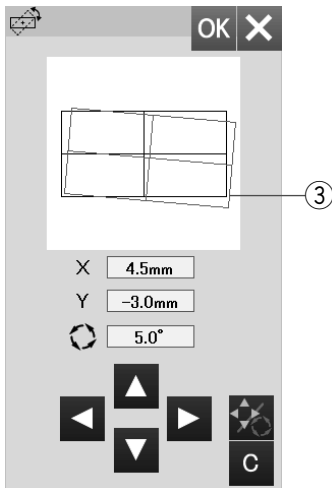

The red rectangle ③ appears when you make fine adjustments to the embroidery design, and it shows the difference between the original position and the adjusted position.

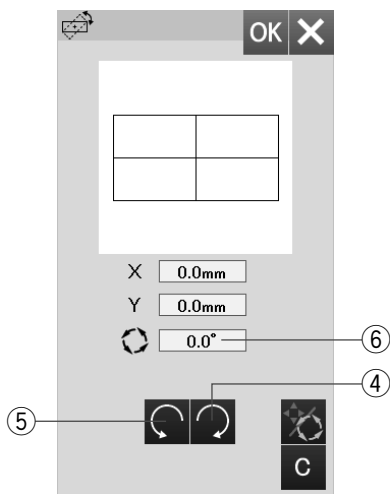

Rotating a design

You can make fine adjustments to the angle of the embroidery design.

Press the key ④ to rotate the design 0.5 degrees clockwise.

Press the key ⑤ to rotate the design 0.5 degrees counterclockwise.

The angle value is displayed in the window ⑥.

NOTE:

The angle of an embroidery design can be adjusted from -5.0 to 5.0 degrees.

The angle of the embroidery design cannot be adjusted to exceed the sewing area.

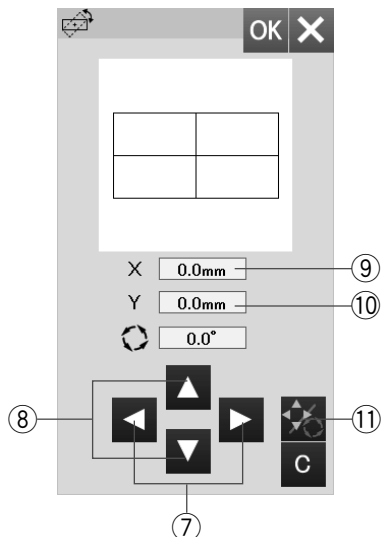

Moving a design

You can make fine adjustments to the position of the embroidery design.

Press the angle/move key ⑪.

The jog keys appear on the screen.

Press the or keys ⑦ to move the design 0.5 mm right or left (X window ⑨).

Press the or keys ⑧ to move the design 0.5 mm forward or backward (Y window ⑩).

The moving distance from the original position is shown as coordinates in the X and Y windows.

NOTE:

The position of an embroidery design can be fine adjusted from -5.0 mm to 5.0 mm.

The position of the embroidery design cannot be adjusted to exceed the sewing area.

The moving distance from the original position is shown only in millimeters.

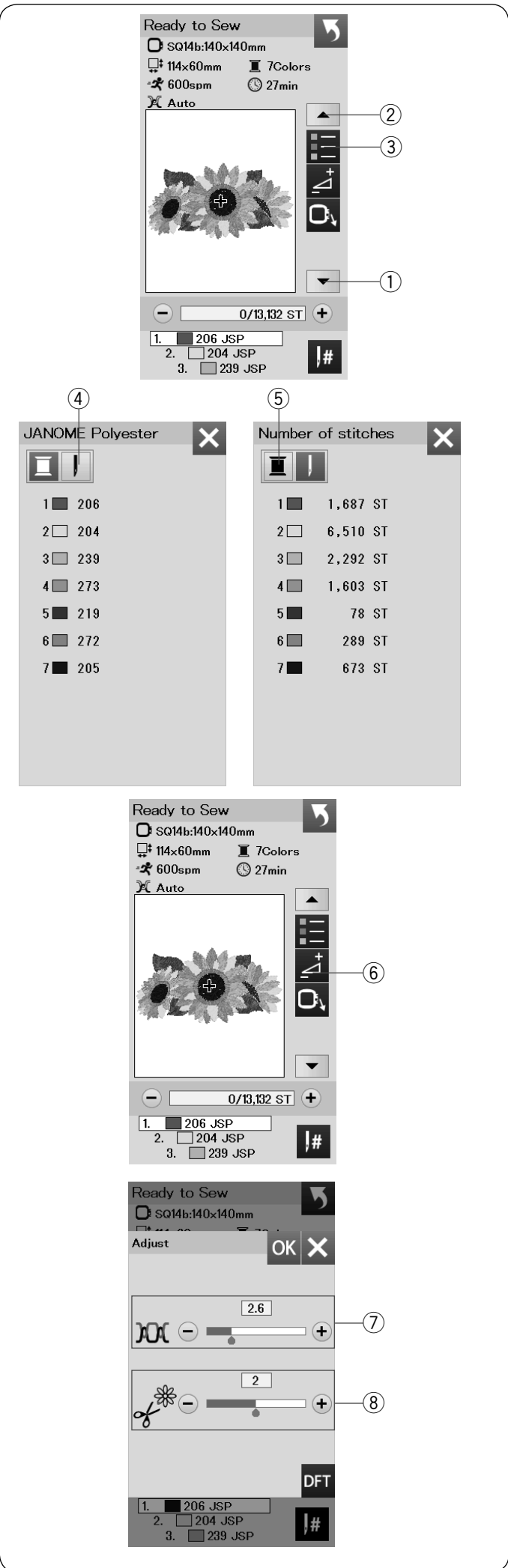

Color list key

Press the down arrow key ① or up arrow key ② to show the next set of function keys.

Press the color list key ③ to view a list of thread colors employed in the selected design.

Press the stitch number key ④ to view a number of stitches for each color in the selected design.

Press the spool key ⑤ to view a list of thread colors employed in the selected design.

Adjust key

Press the adjust key to open the manual setting window. You can adjust the following settings in this window.

⑥ Adjust key

⑦ Auto thread tension level

Press the “+” or “-” key to adjust the thread tension to your preference.

⑧ Cutting the tails of jump threads

This option is can be used when the “jump thread cutting length” setting or “cutting command” is activated (refer to page 53).

Press the “+” or “-” key to adjust the tail length of jump thread.

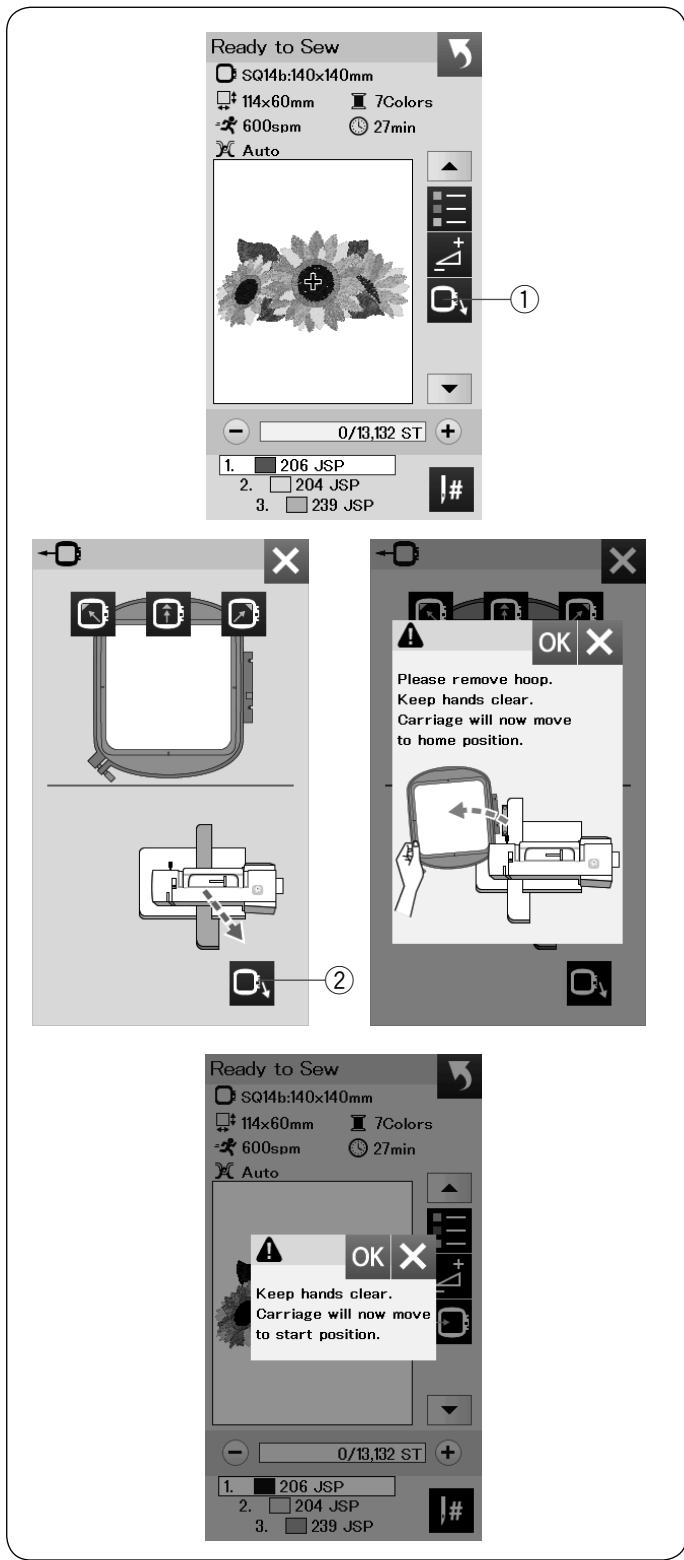

Hoop back key

Turn the handwheel toward you to raise the needle at its highest position if the needle is in down position.

Raise the presser foot.

Press the hoop back key ① and hoop back option window will open.

Press the key ② and the confirmation window open.

Press the OK to move the carriage back to the home position and return to the Ready to Sew screen. Press one of the keys to move the carriage to a standby position.

Press the X key to close the hoop back option window.

② Hoop back key

Press the start/stop button.

The caution message appears.

Press the OK key and the hoop will go back to the original position.

Starting to Sew Embroidery

- 1 Select the desired pattern.
Press the thread color/Jog key ①. The jog keys appear.

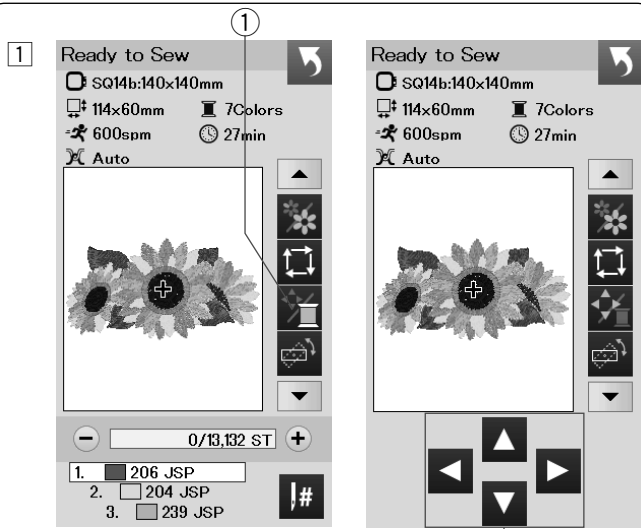

②

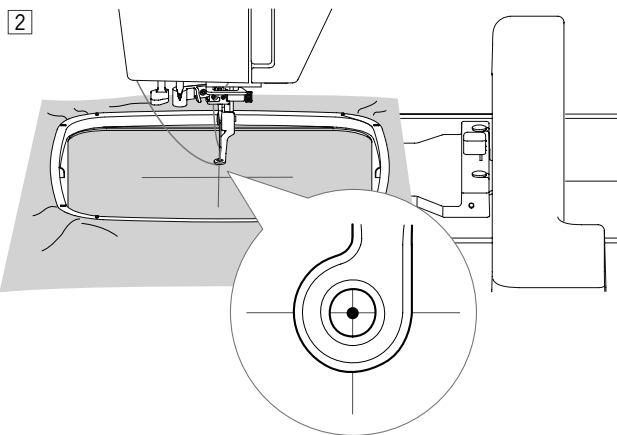

- 2 Adjust the hoop position with the jog keys so that the needle position comes right above the center of the centerlines on the fabric.

② Jog keys

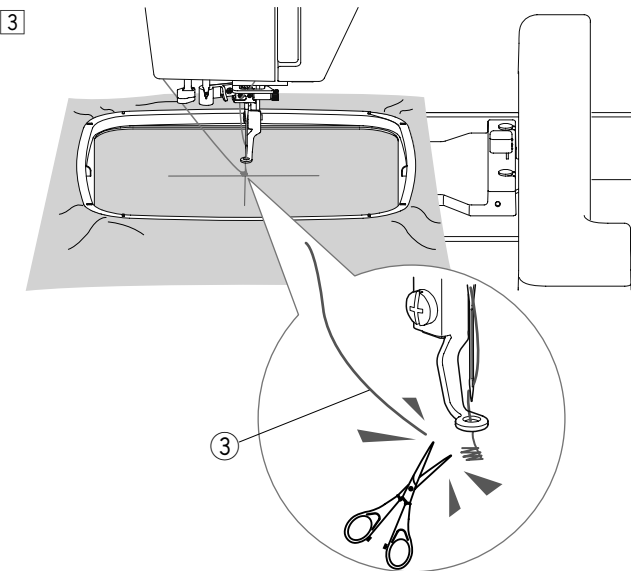

- 3 Press the start/stop button and sew 5 to 6 stitches.
Press the start/stop button again to stop the machine.
Cut the loose thread close to the beginning of the starting point.

③ Loose thread

Press the start/stop button to start sewing again. The machine will stop (and trim the threads if the auto thread cutting is activated) automatically when the first color section is finished. Change the thread to the next color and sew the next section.

You can adjust the sewing position with the jog keys during the sewing if necessary. Press the start/stop button to stop the machine. Press the jog keys to move the hoop at the desired position. Press the start/stop button again to continue sewing.

NOTE:

The needle drop position will resume the original position after all the color sections are finished.

Sewing results

The embroidery pattern is sewn against the centerlines on the fabric as shown.

④ Centerlines on the fabric

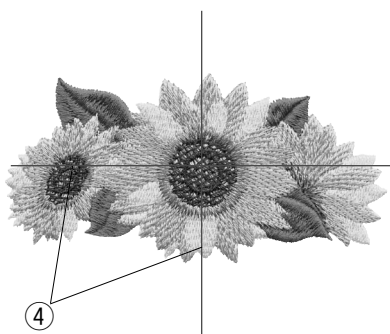

NOTE:

Refer to page 53 for how to set auto thread cutting.

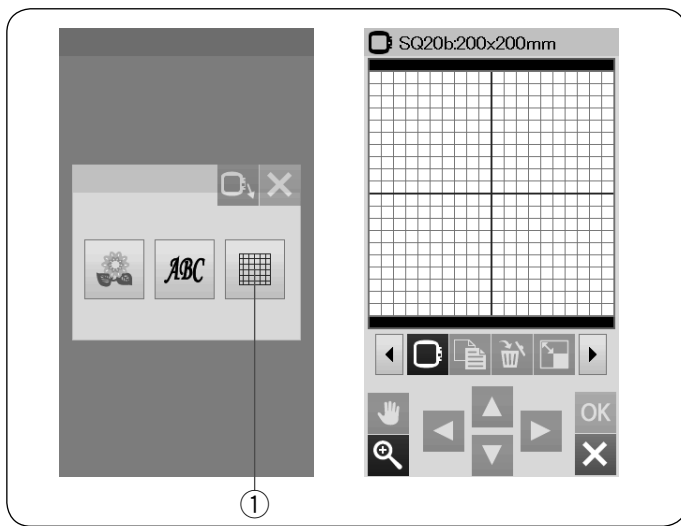

Editing Mode

In the editing mode, you can edit and combine patterns to create original embroidery designs.

Press the editing mode key ① and the editing window for the hoop SQ20b will open.

- ① Editing mode key

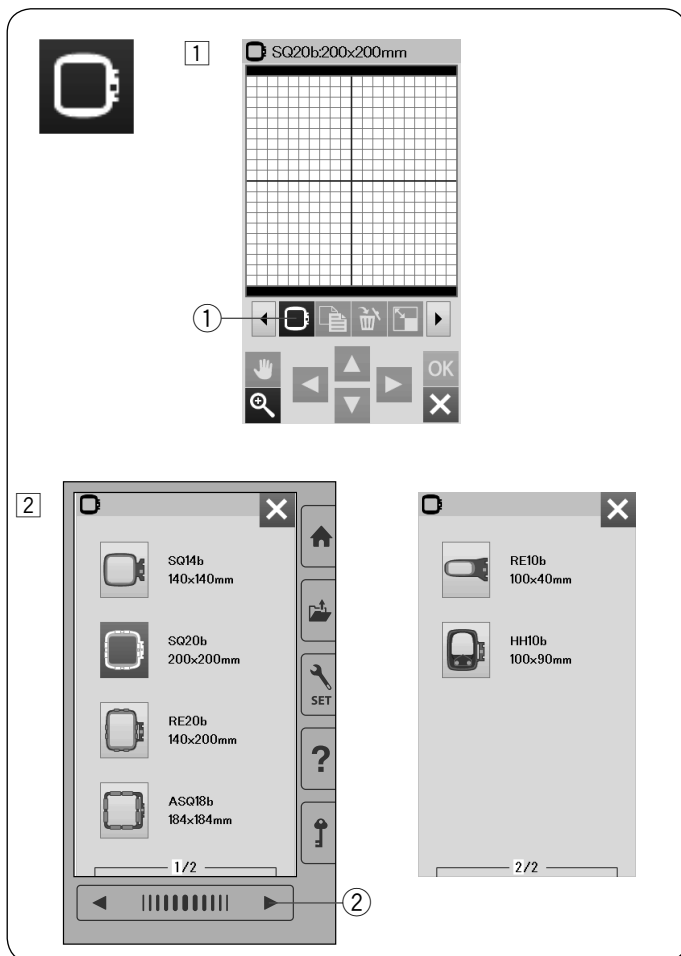

Selecting a hoop size

You can select other hoop sizes.

- ① Press the hoop selection key ① and the hoop selection window will open.

- ① Hoop selection key

- ② Press the next page key ② to show the other hoops. Press the hoop icon key to select the desired hoop. The screen will return to the editing window.

- ② Next page key

NOTE:

- In the editing mode, you cannot select patterns larger than the size of the selected hoop.
- Some of the hoops are not included with the machine.

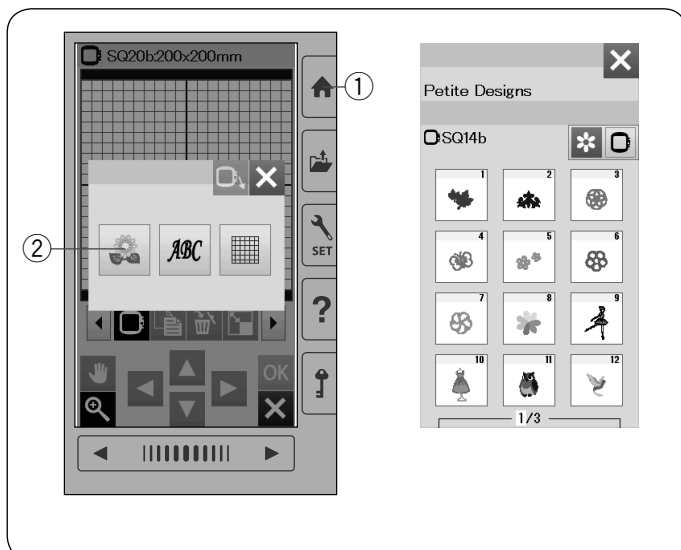

Opening the embroidery designs

You can open the built-in designs, monogram, and designs from the USB flash drive in the editing window.

To open design patterns, press the home key ①.

Press the built-in design key ②.

Select the desired pattern from the design list.

- ① Home key

- ② Built-in design key

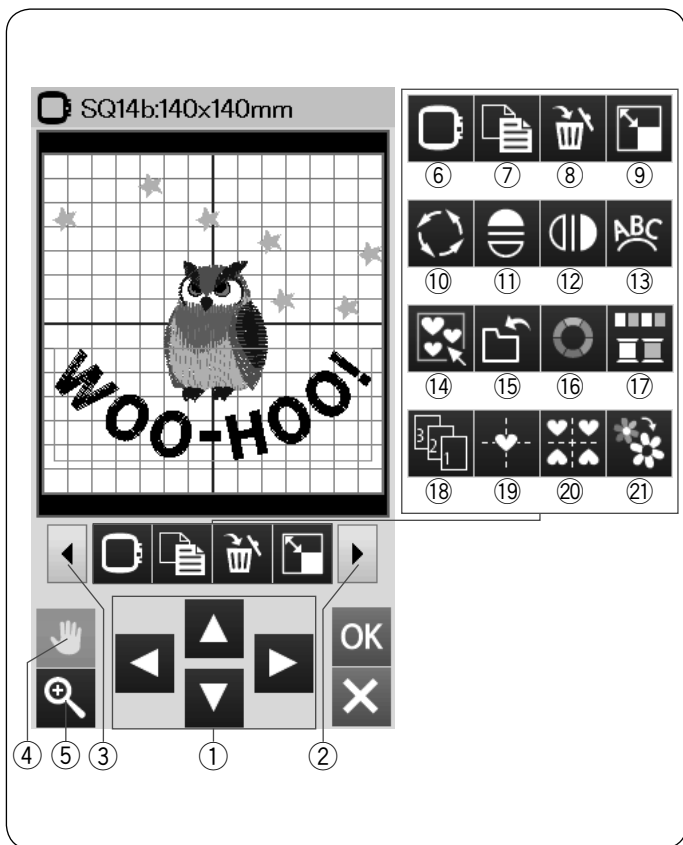

Editing tool bar information

The editing tool bar contains the following keys as shown. Press the next set key ② to show the next set of editing tools. Press the previous set key ③ to show the previous set of editing tools.

- ① Layout keys
- ② Next set key
- ③ Previous set key
- ④ Scroll key
- ⑤ Zoom key
- ⑥ Hoop selection key
- ⑦ Duplicate key
- ⑧ Delete key
- ⑨ Resize key
- ⑩ Rotate key
- ⑪ Horizontal mirror image key
- ⑫ Vertical mirror image key
- ⑬ Arc key
- ⑭ Group key
- ⑮ Save file key (refer to page 55)
- ⑯ Custom color key
- ⑰ Color group key
- ⑱ Sewing order key
- ⑲ Center position key
- ⑳ Corner layout key
- ㉑ Single color sewing key

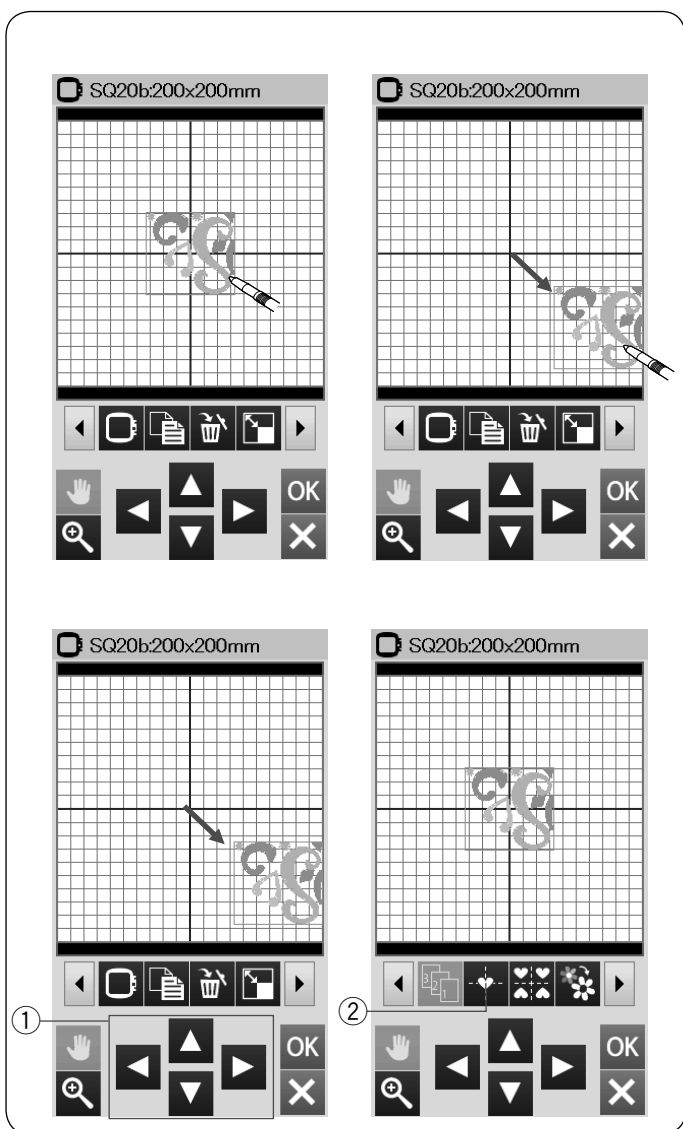

Selecting a pattern

To select the pattern to edit, press on the pattern image in the editing window.

The green frame appears around the selected pattern.

Moving a pattern

To move the embroidery pattern in the editing window, press and drag the pattern to a desired location with the touch panel stylus or your fingertip.

NOTE:

Do not drag the pattern on the screen with a sharp pointed object.

You can move the selected pattern also by pressing the layout keys.

Press the layout keys ① to move the pattern to the desired position in the editing window.

Press the center position key ② to move the pattern to the center of the editing window.

- ① Layout keys
- ② Center position key

The carriage will not move when you press the layout keys since the pattern position will move relative to the hoop, not to the machine.

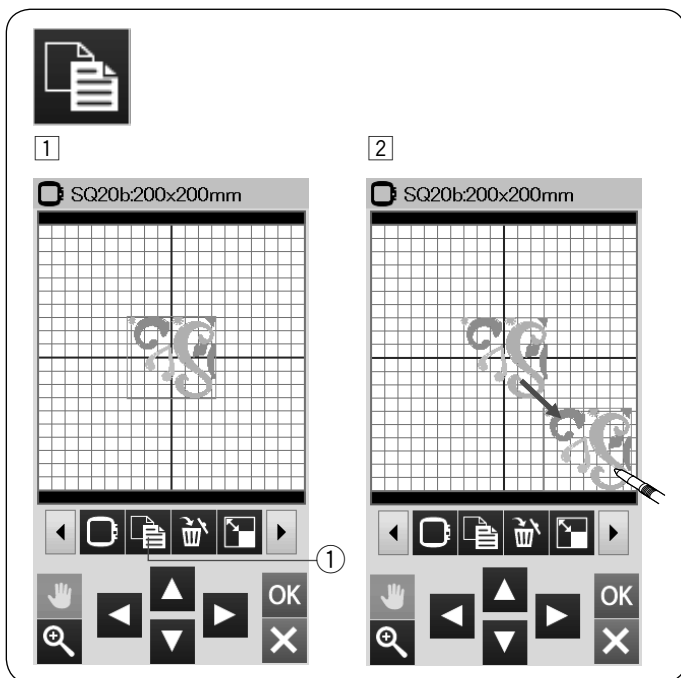

Duplicating a pattern

- 1 Press the duplicate key to make a copy of the selected pattern.
 - ① Duplicate key
- 2 The duplicated pattern will be superimposed over the original pattern. Move the duplicate to show the original pattern.

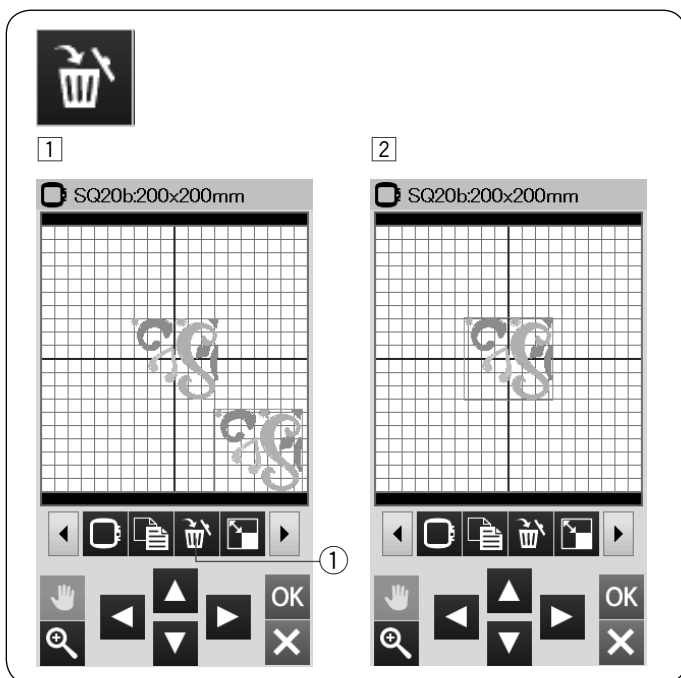

Deleting a pattern

- 1 Press on the pattern to delete.
 - ① Delete key
- 2 Press the delete key to delete the selected pattern.

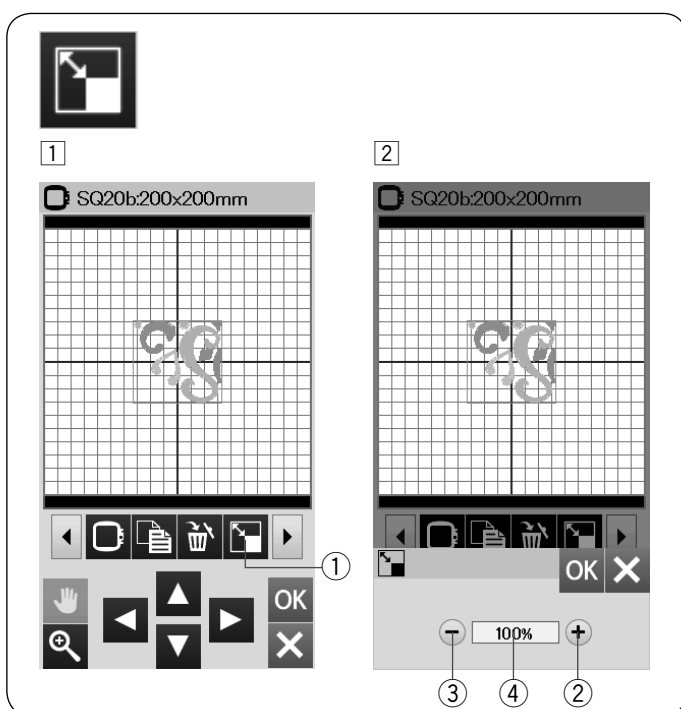

Resizing a pattern

- 1 Press the resize key to open the resize option window.
 - ① Resize key
- 2 You can change the embroidery pattern size from 80% to 120% of the original size. Press the “+” key ② to enlarge the pattern size. Press the “-” key ③ to reduce the pattern size. The size will change 1% each time you press the “+” or “-” key. To change the size quickly, press and hold the “+” or “-” key. The scale of a resized pattern is displayed in percentage ④. Press the OK key to confirm the new size.

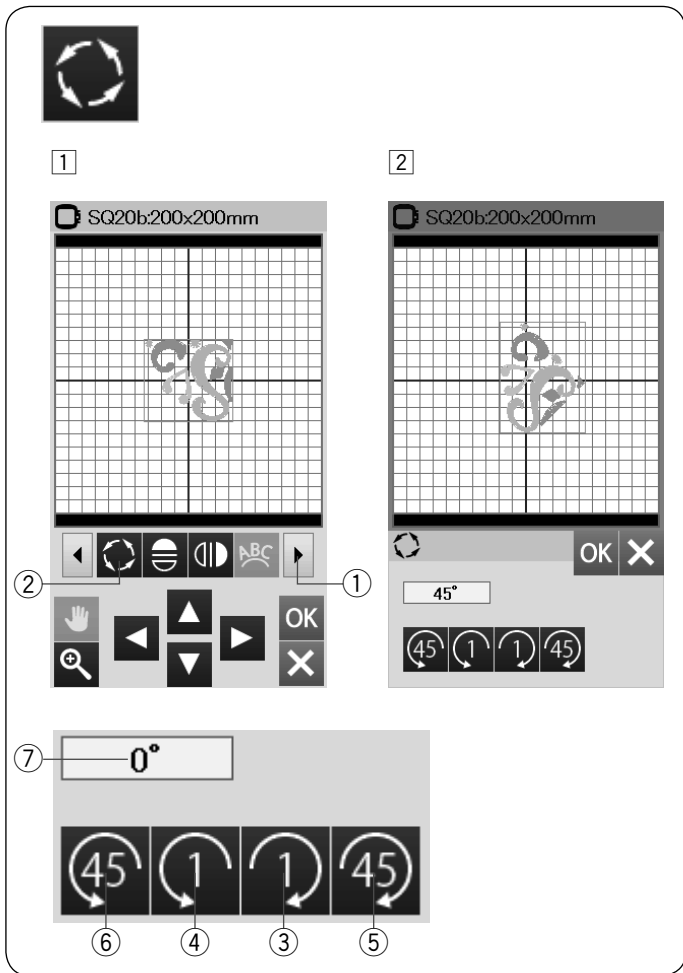

Rotating a pattern

- 1 Press the next set key ① to show the next set of editing tools.
Press the rotate key ② to open the rotation option window.
② Rotate key
- 2 Press the ④ key ③ to rotate the selected pattern 1 degree clockwise.
Press the ⑤ key ④ to rotate the selected pattern 1 degree counterclockwise.
Press the ⑥ key ⑤ to rotate the selected pattern 45 degrees clockwise.
Press the ⑦ key ⑥ to rotate the selected pattern 45 degrees counterclockwise.
The angle of a rotated pattern is displayed in the window ⑦.
Press the OK key to confirm.

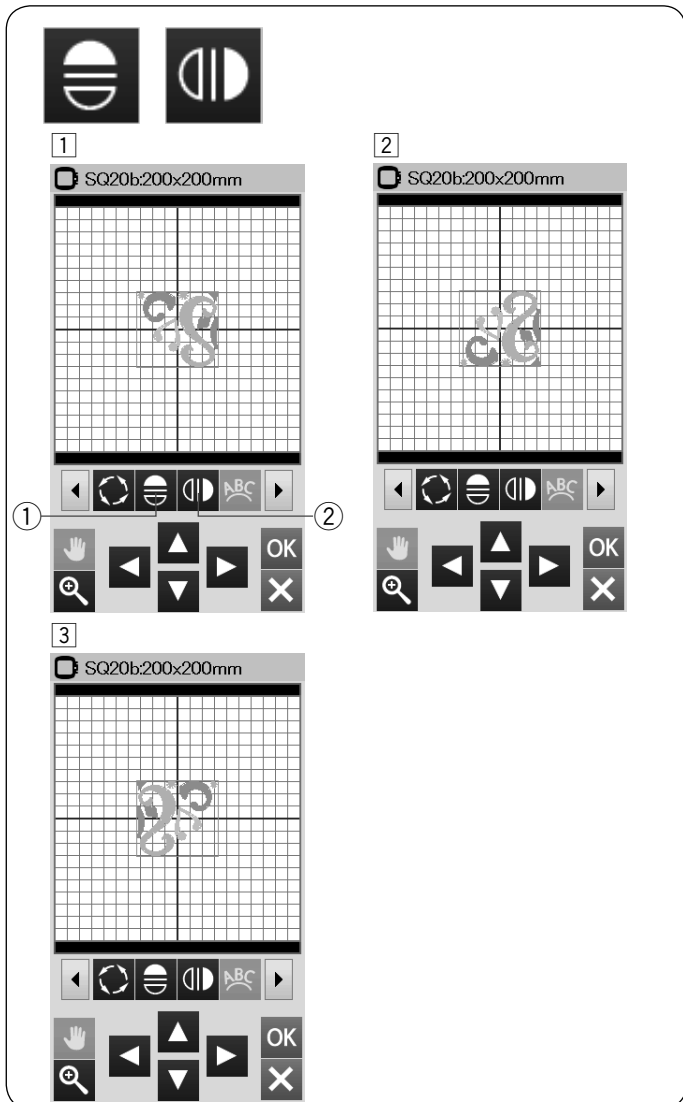

Flipping a pattern

- 1 Press the vertical or horizontal mirror image key.
① Horizontal mirror image key
② Vertical mirror image key
- 2 Press the ① key ① to create the horizontal mirror image of a selected pattern.
- 3 Press the ② key ② to create the vertical mirror image of a selected pattern.



1



2

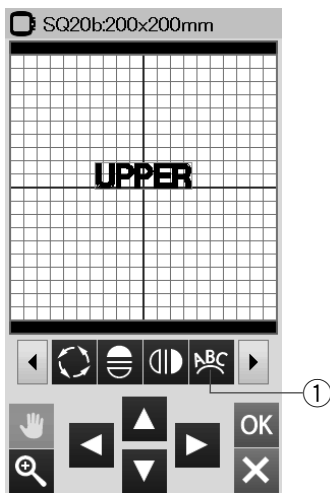

3

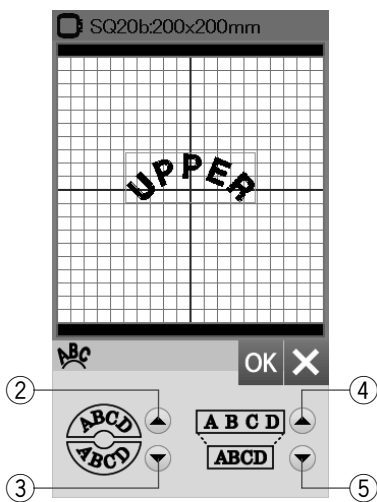

Monogramming in an arc

In the editing mode, you can make a monogram in an upper or lower arc.

1 Enter the characters and press the OK key.

2 The entered characters are displayed in the editing window.
Press the arc key and the arc layout window will open.

1 Arc key

3 Press the upper arc key 2 to make an upper arc.
Press the lower arc key 3 to make a lower arc.
Press the enlarge key 4 to make an arc longer.
Press the shorten key 5 to make an arc shorter.
Press the OK key to confirm.

2 Upper arc key

3 Lower arc key

4 Enlarge key

5 Shorten key

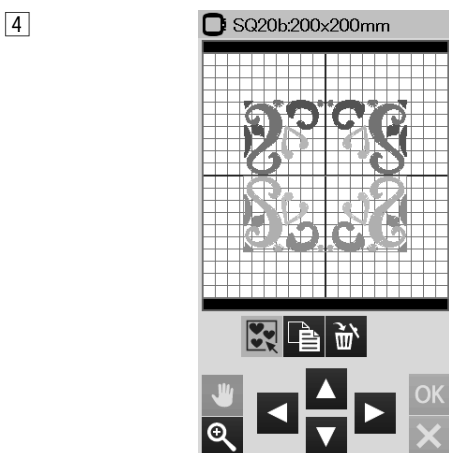
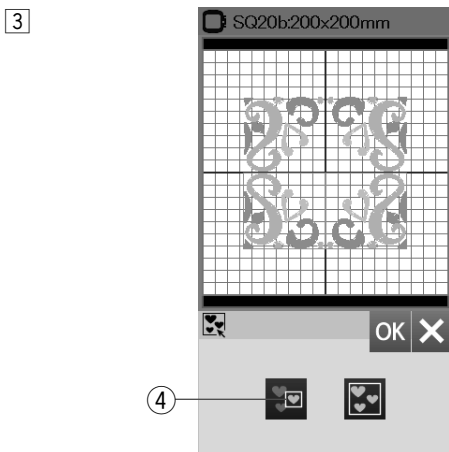
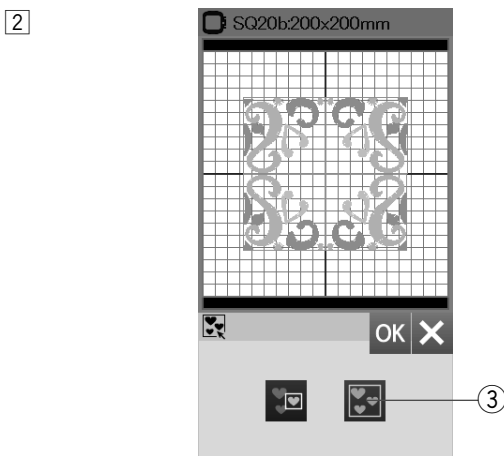
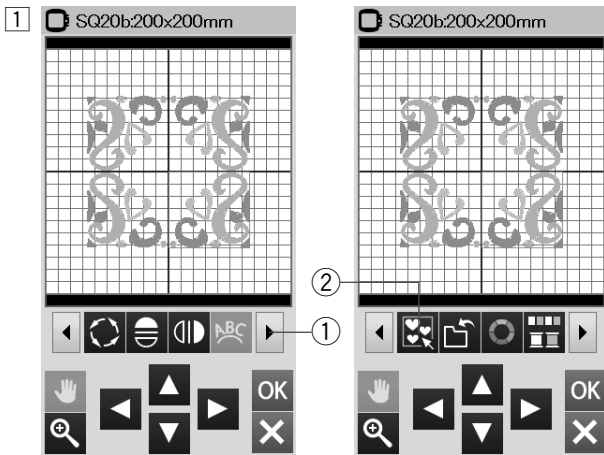

Grouping patterns

- 1 You can group patterns together.
Press the next set key ① to show the next set of editing tools.
Press the group key ② and the grouping option window will open.

- ① Next set key
- ② Group key

- 2 Press the group all key ③ and press the OK key to group all the patterns in the editing window.

- ③ Group all key

- 3 If you wish to group the selected patterns only, press the group select key ④.
Select the desired patterns by pressing on the pattern images.

Press the selected pattern again to deselect the pattern.

Press the OK key to group the selected patterns.

- ④ Group select key

- 4 The grouped patterns can be moved and duplicated as a unit.

When grouping the selected patterns only, the rest of the patterns are grayed out and cannot be selected.

To ungroup the patterns, press the group key again.

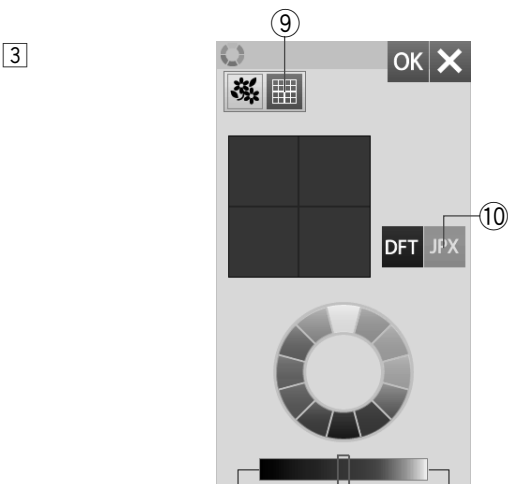
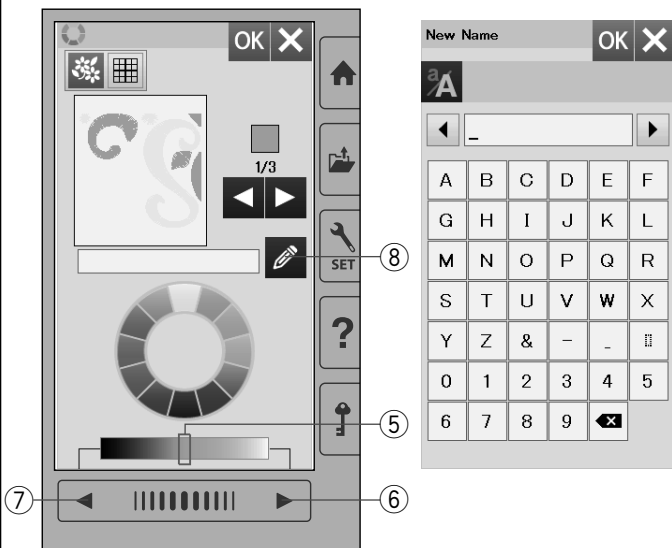
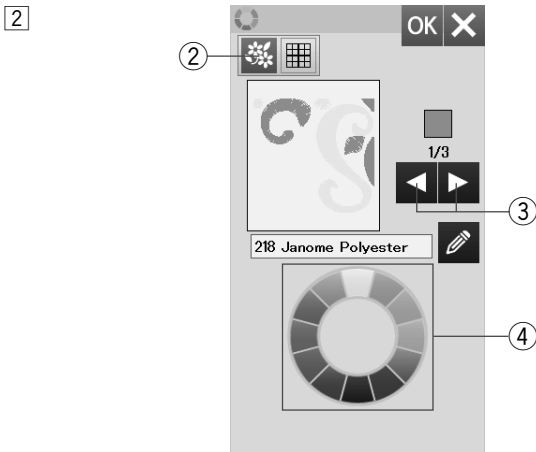
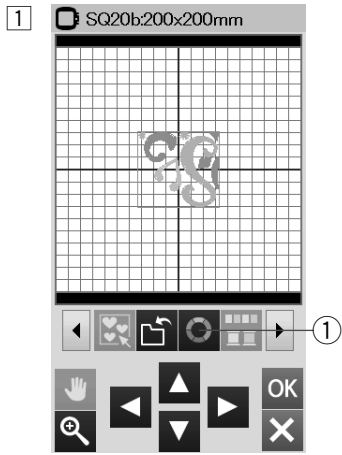

Customizing the display colors

You can simulate the colors of the actual fabric and threads on the screen by customizing the colors of the design image and editing window.

- 1 Press the custom color key and the custom color window will open.

① Custom color key

- 2 If you wish to change the color of the design pattern, press the design color key. Press the scroll keys until the desired section is displayed in the preview window.

② Design color key

③ Scroll keys

To select the hue, press one of the 12 color tiles.

④ Color tiles

To change the shade of the selected color, press next page key, previous page key, or drag the slider to the left or right.

⑤ Slider

⑥ Next page key

⑦ Previous page key

You can assign a name to the customized color for the color section by pressing the name key.

The assigned name will be displayed instead of the name and code of the thread color in the embroidery window.

⑧ Name key

- 3 To change the background color, press the background color key and select the desired color.

To select the hue, press one of the 12 color tiles.

To change the shade of the selected color, press next page key, previous page key, or drag the slider to the left or right.

⑨ Background color key

NOTE:

If a design in *.JPX format has a background image, you can display the background image in the editing window by pressing the background image key.

⑩ Background image key

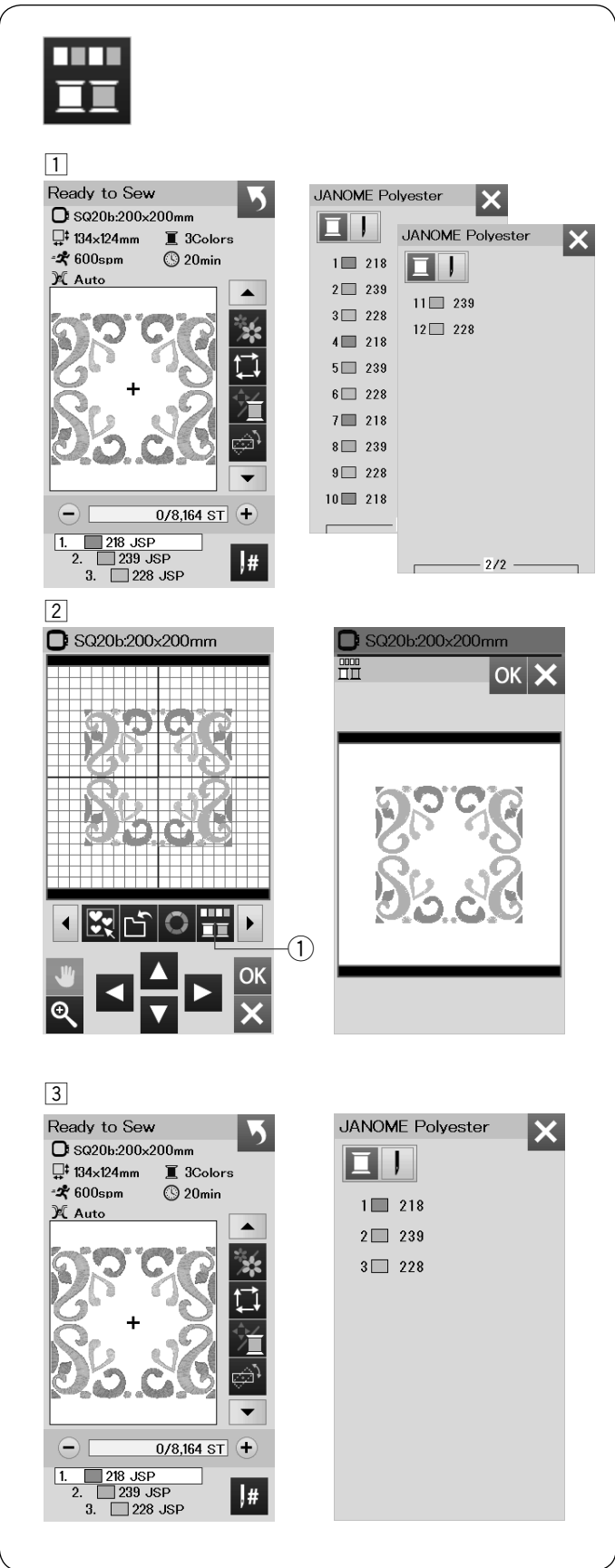

Color grouping

When combining duplicated patterns, you can reduce the number of color sections with color grouping.

1 For example, the combined design pattern created on page 42 has 12 color sections.

2 Press the color group key ① and the color grouping window will open.

Press the OK key to unite all color sections of the same color and the ready to sew window opens.

① Color group key

3 The number of color sections is reduced to 3.

NOTE:

Color grouping will be cancelled when returning to the editing window.

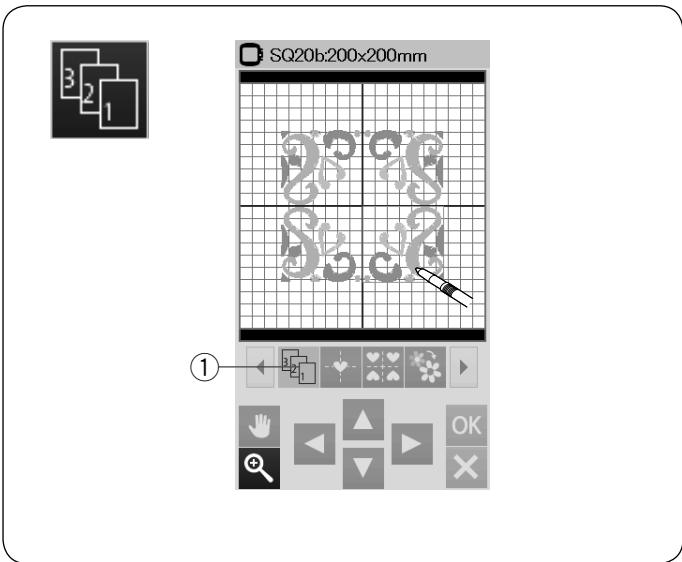

Sewing order

You can change the sewing order of a pattern combination.

Press the sewing order key ① and press on the images of the pattern one by one.

The patterns will be sewn in the order you press on the images.

Press the sewing order key ① again to return to the previous screen.

- ① Sewing order key

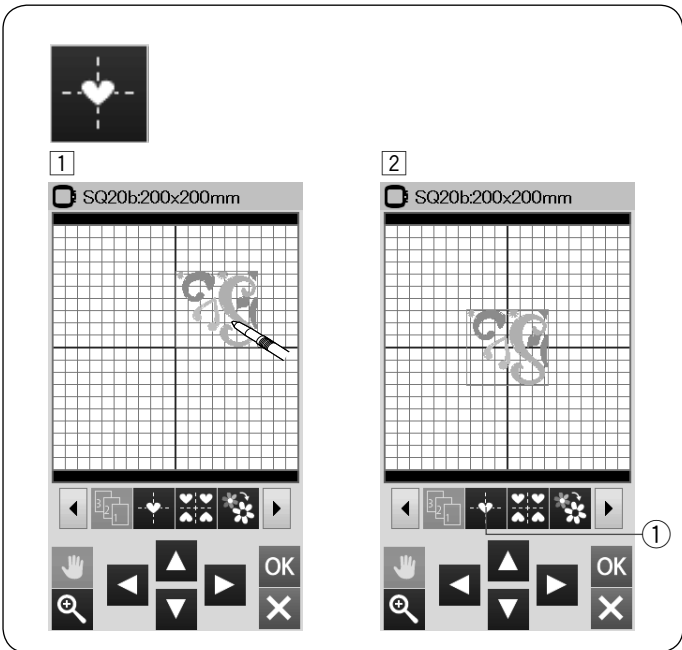

Center positioning

You can move the selected pattern to the center position.

1 Press on the pattern to move.

2 Press the center position key ① to move the selected pattern to the center position.

- ① Center position key

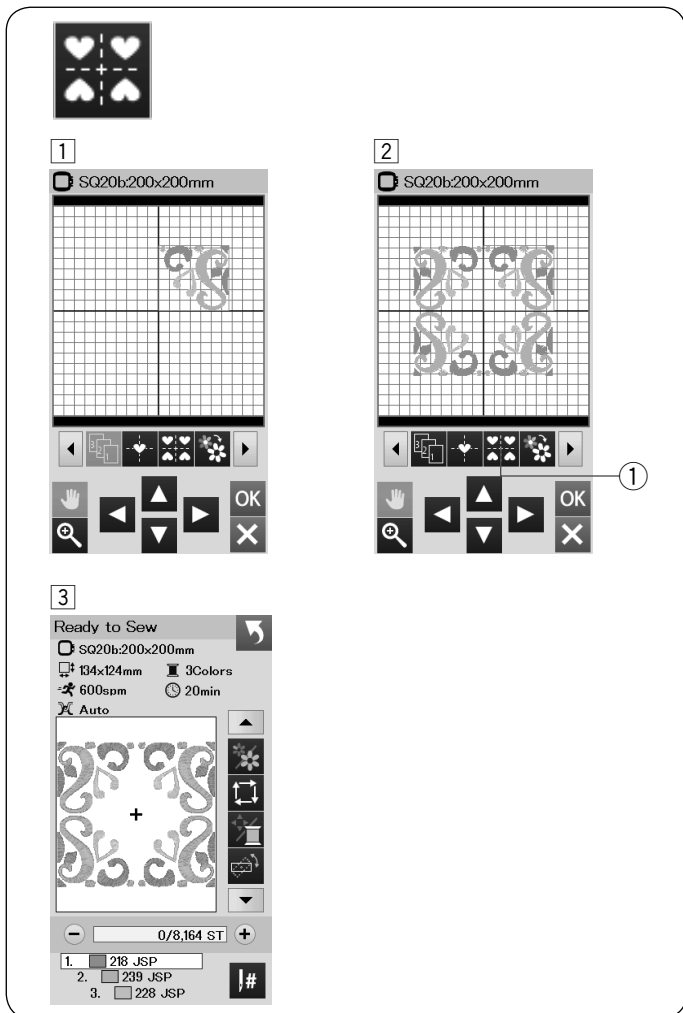

Creating a square frame

- 1 Select pattern Geometric Design SQ14B-56. Move the design up and to the right.
- 2 Press the corner layout key. The pattern will automatically be copied and placed symmetrically into 4 corners. Press the OK key.
 - ① Corner layout key
- 3 The ready to sew window will open.

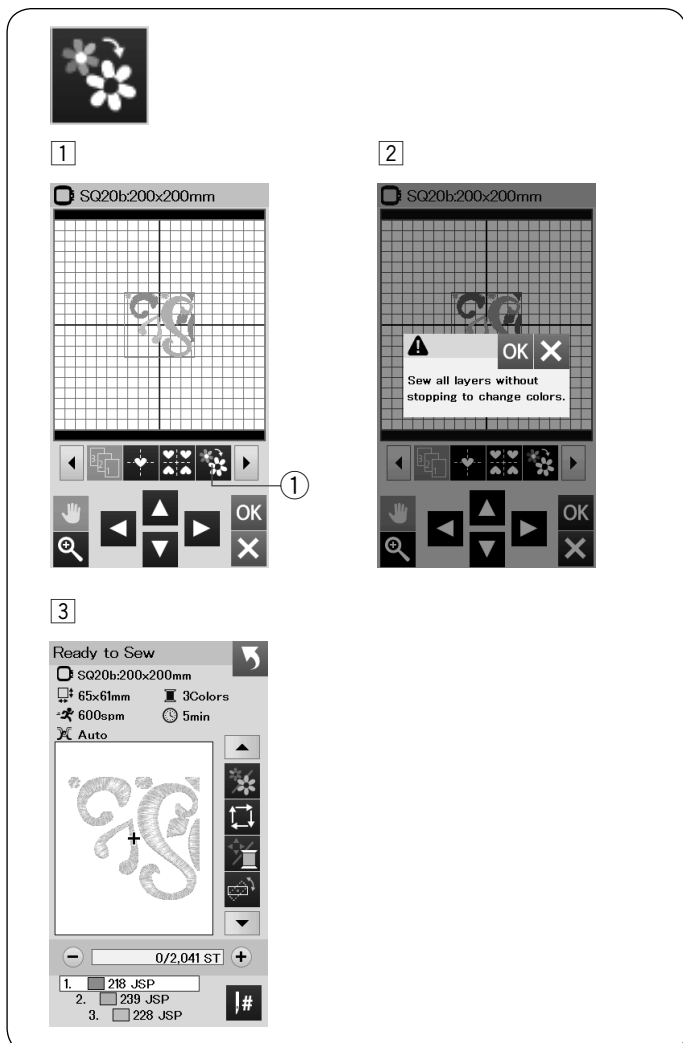

Single color sewing

If you want to sew a pattern or a pattern combination in one color only, press the single color sewing key ①. The machine will not stop until the entire design is sewn.

- 1 Press the single color sewing key ①.
- 2 Press the OK key.
- 3 The design(s) will be displayed in gray. Press the start/stop button to start single color sewing. The design will be sewn without stopping for color change.

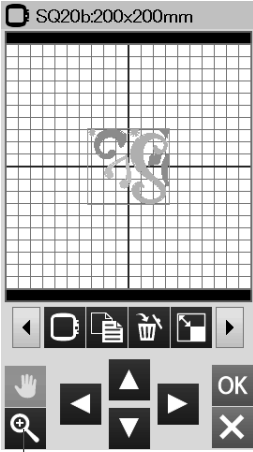

①

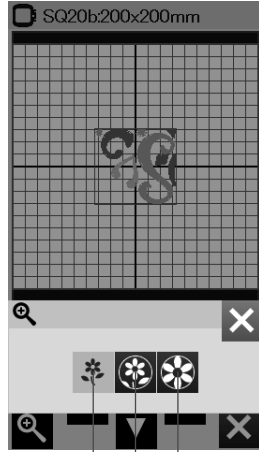

②

③

④

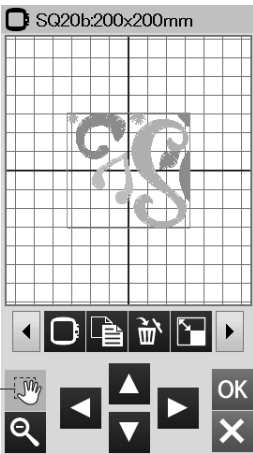

⑤

Zooming in the editing window

Press the zoom key to open the zoom in/out window. Select the view size from normal, large or largest by pressing one of the view size keys.

- ① Zoom key
- ② Normal view size key
- ③ Large view size key
- ④ Largest view size key

The scroll function is activated automatically when zoomed in.

To scroll the magnified window, drag the window in the desired direction.

Press the scroll key to cancel the scroll command.

- ⑤ Scroll key

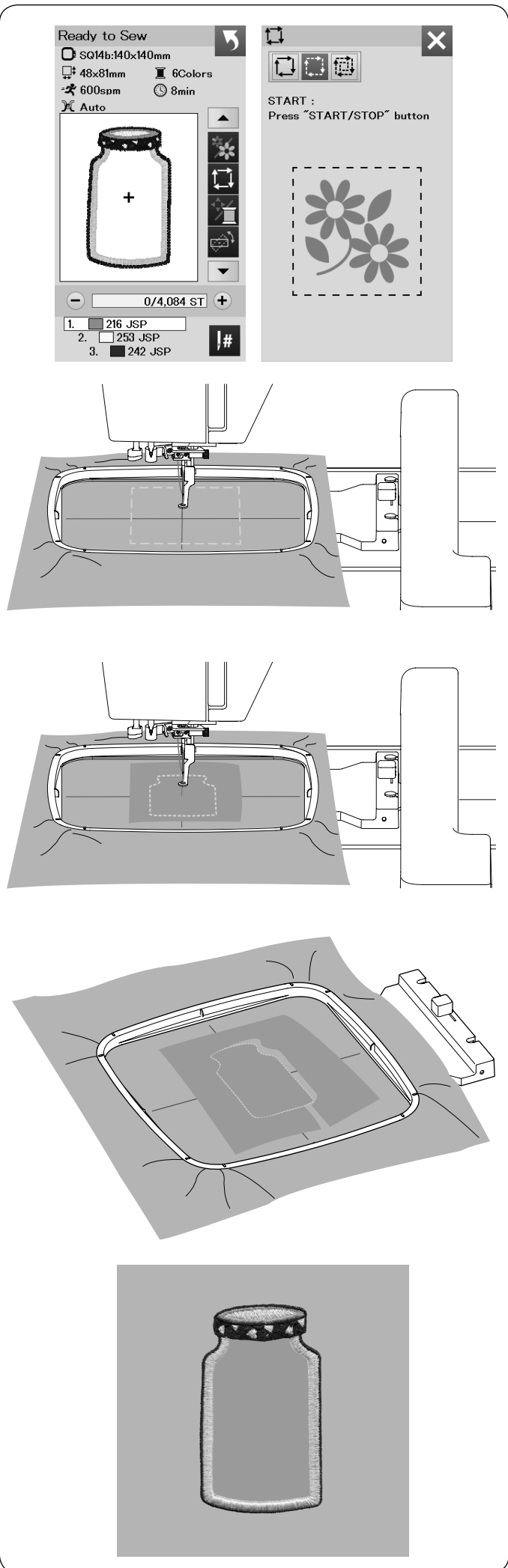

Pantry Designs for Applique

Pantry designs SQ14b-67 to SQ14b-69 are special designs for machine embroidery applique. You can attach applique piece to background fabric and embroider applique design at the same time.

Example: Pantry design SQ14b-67

Prepare background fabric and applique fabric. Select Pantry design SQ14b-67, and set the background fabric to the hoop.

Attach the hoop to the carriage and press the trace key. Press the  key to select trace and baste (single) (refer to page 28). Start the machine to mark around embroidery design with basting stitches.

Cut the applique fabric the same size as the marked area. Place the applique piece on the marked area and sew the first section (color).

NOTE:

Pin the applique piece or use spray adhesive to fix it in place as necessary.

Remove the hoop from the machine, but do not unhoop the fabric. Remove the basting stitches. Cut away the excess applique fabric as close to the seam line as possible.

Attach the hoop to the machine again. Sew the remaining sections (colors) of the applique design.

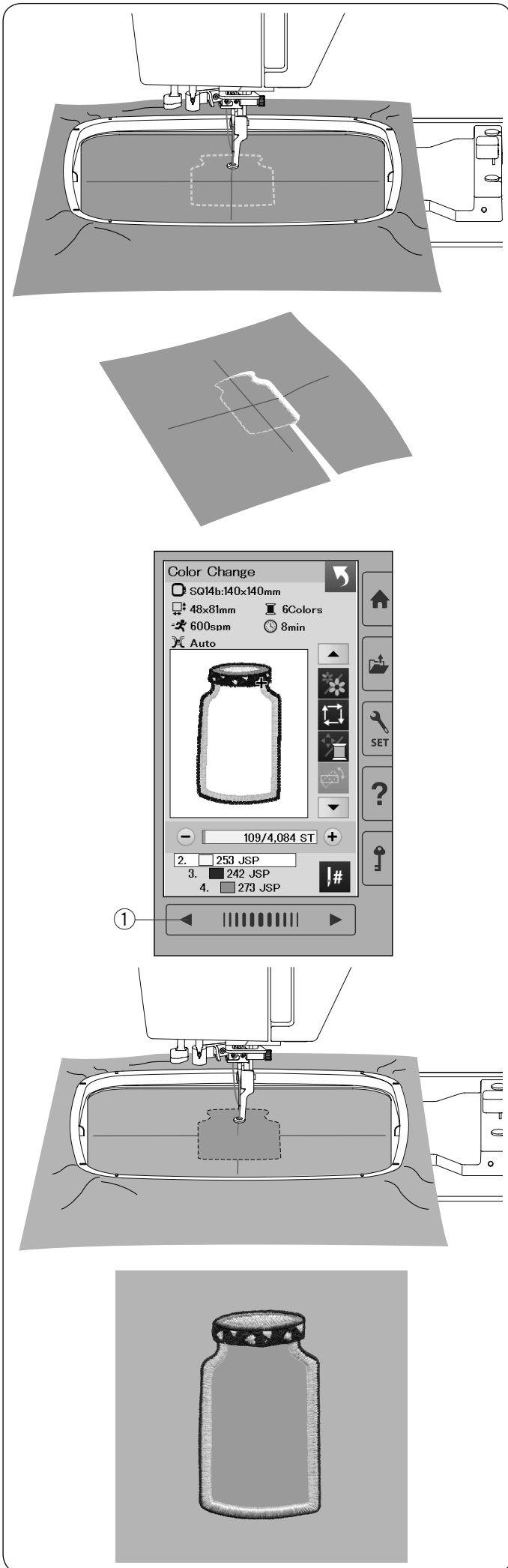

Alternative method

Prepare applique fabric larger than hoop size.
 Set the applique fabric to the hoop.
 Sew the first section (color) only.

Remove the hoop and unhoop the applique fabric. Cut the applique fabric along the stitching line to make an applique piece.

Prepare background fabric and set it to the hoop.
 Attach the hoop to the carriage.
 Press the previous page key to go back to the first section (color) and sew the first section (color) to mark the applique position.

① Previous page key

Place the applique piece on the background fabric and align the applique piece with the positioning mark. Fix the applique piece in place with sticky tape or a pin.

Sew the remaining sections (colors) of the applique design.

Celebration Designs

You can make your own flag garland with the celebration designs.

1 Select the design list by hoop size and select the hoop SQ20b.
Select design pattern SQ20b-39.

2 Edit your pennant design in the editing mode.

3 Press the OK key to open the ready to sew window.
Set the fabric in the hoop and attach the hoop to the carriage.
Press the start/stop button to sew.

4 Remove the hoop from the carriage when finished sewing.
Remove the fabric from the hoop.
Cut out the pennant design along the outer seam.

5 Fold back the top of the pennant to the wrong side of the fabric as shown.
Use press cloth and Iron the folded edge.

6 Sew the folded edge or paste the wrong side of the folded edge with a double-sided tape or glue.
Be sure to leave the space to pass the cord.

7 Pass the cord through the hole as shown.

8 Cut the fabric to the same size as the pennant design.
Sew the fabric to cover the back of the pennant.

9 Repeat the procedure above and make your own flag garland.

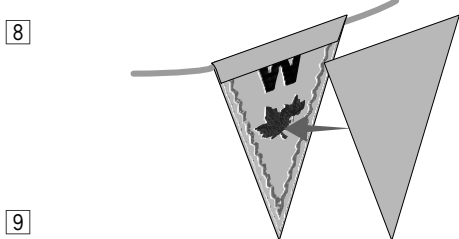
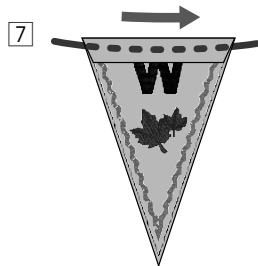
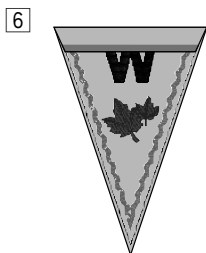
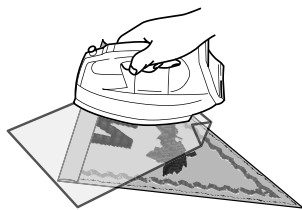
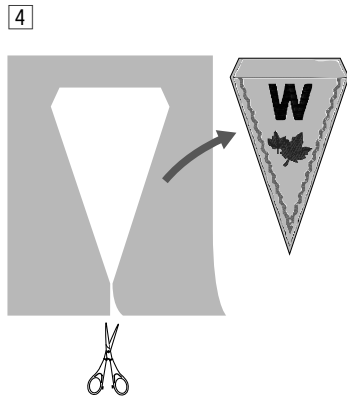
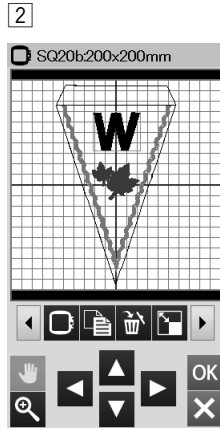
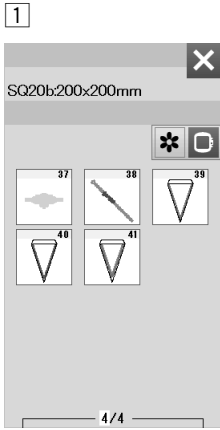

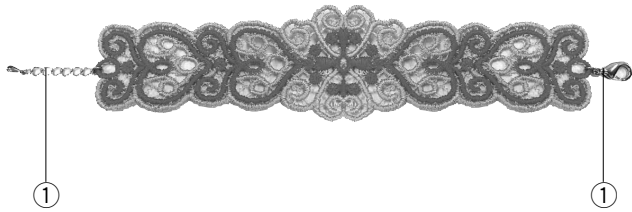
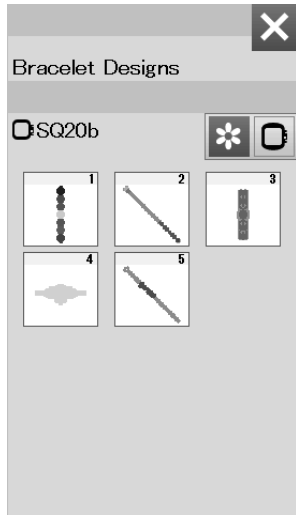

Bracelet Designs

You can make a your own bracelet by sewing the bracelet designs on a water soluble stabilizer.

Use the same thread for the bobbin as the needle thread.
Use a fully wound bobbin.

Set the low bobbin thread warning level to 3 or 4 (refer to page 51).

Set the maximum sewing speed to 600 spm or less (refer to page 51).

Set the water soluble stabilizer in the hoop.

Be sure that the stabilizer is stretched tightly in the hoop.
Select the desired bracelet design pattern and sew.

Remove the water soluble stabilizer from the hoop.
Trim away the water soluble stabilizer surrounding the design pattern with scissors.

Remove the water soluble stabilizer by soaking the bracelet design into the bowl of warm water.

Attach the chain rings* to the each end of the bracelet.

① Chain ring

* Chain rings are not included with the machine.

CUSTOMIZING MACHINE SETTINGS

Machine Setting Mode

Press the set mode key to enter the machine setting mode.

You can select various options and customize the machine settings to suit your personal preference.

① Set mode key

Press one of the 3 tabs to select the mode to customize.

② Common Setting Mode

Press the common setting mode tab to enter the common setting mode.

In this mode, you can customize the general machine settings and options.

③ Embroidery Setting Mode

Press the embroidery setting mode tab to enter the embroidery setting mode.

In this mode, you can customize the machine settings and options for embroidery (refer to pages 51-54 for the operation).

④ Language Selection Mode

Press the language selection tab to enter the language selection mode.

In this mode, you can select the desired language for the screen messages.

To browse pages in each mode, press the next page key or previous page key

⑤ Previous page key

⑥ Next page key

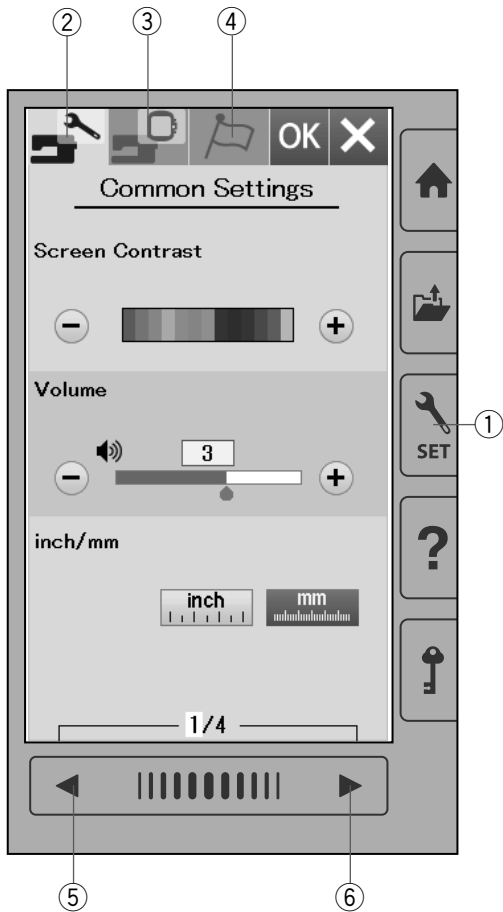

Registering the custom settings

After customizing the settings, press the OK key to enable the new settings.

To cancel the changes to the settings, press the X key and the setting mode window will close.

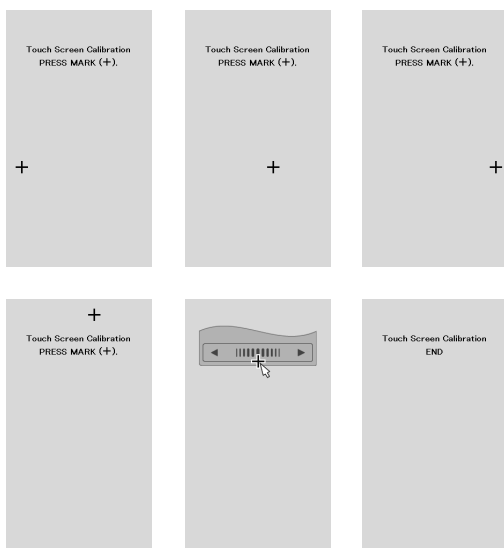
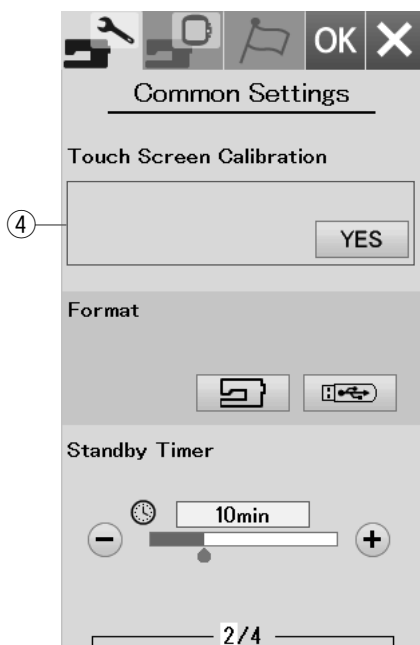
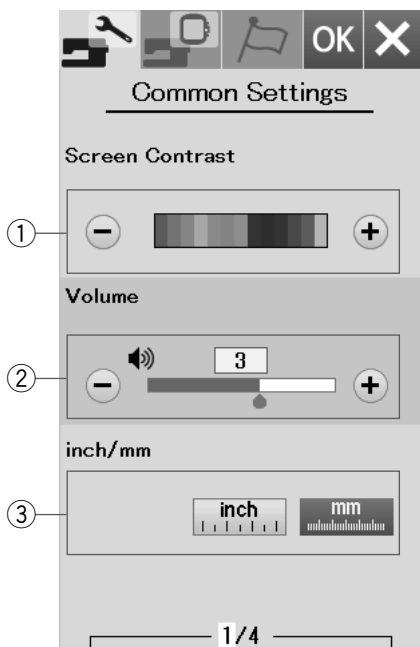

Common Setting Mode

① Screen Contrast

You can adjust the contrast of the visual touch screen by pressing the “+” or “-” key.

② Sound Volume

The signal sound can be adjusted by pressing the “+” or “-” key.

Set the value to “OFF” by pressing the “-” key several times to mute the signal sounds.

③ Inch/mm Option

You can set your machine’s dimensional unit to either inches or millimeters by pressing the “inch” or “mm” icon key.

The default unit is millimeters.

Press the next page key to show the next menu.

④ Touch Screen Calibration

You can calibrate the key positions of the touch screen if you feel the touch screen key is not responding properly.

Press the Yes key to open the calibration window.

Press the “+” sign with the touch panel stylus as the sign appears.

When you press the last sign, the screen shows “END” and the calibration window will close.



⑤ Formatting the memory

If the internal memory of the machine or USB flash drive does not function due to damage to the memory bank, you need to re-enable it by formatting the memory.

To format the machine's internal memory, press the machine icon key and a confirmation message will appear. Press the OK key to format.

To format a USB flash drive, press the USB icon and the confirmation window will open. Press the OK key to format.

⚠ CAUTION:

Do not turn off the power or disconnect the USB flash drive while a warning message is displayed otherwise it may damage the memory bank.

⑤

⑥

⑥ Standby Timer

The sewing lights will turn off and the machine will enter standby mode if you do not use the machine within the time period set by this timer. Doing any operation will turn the lights and screen on again.

The standby timer can be set from 1 to 30 minutes. If you wish to turn off the timer, press and hold the “+” key until “OFF” shows in the timer window.

Press the next page key to show the next menu.

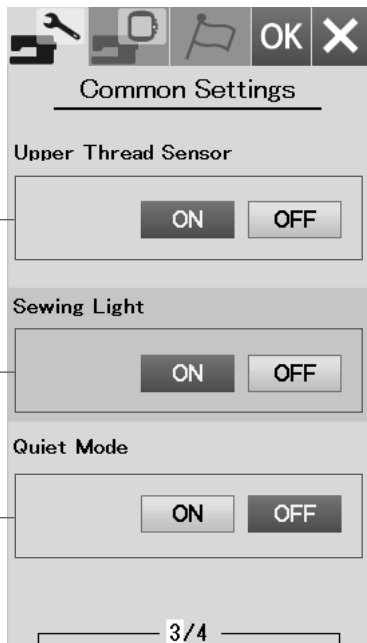

⑦ Upper Thread Sensor

If you need to run the machine without threads, turn off the upper thread sensor.

⑧ Sewing Light

The sewing lights can be turned on or off. Press the ON key to turn on the sewing lights. Press the OFF key to turn off the sewing lights.

⑨ Quiet Mode

If you prefer the machine to run more quietly, turn on this option so the signal sound and maximum embroidery speed will be set at the lowest levels. The quiet mode setting overrules any previous settings for these parameters.

⑦

⑧

⑨



⑩ Clean bobbin holder message

The caution message for cleaning the bobbin case and the hook race will be displayed when the certain time passes when this option is turned on. The caution message will not be displayed when this option is turned off.

⑪ Background Color

You can select from the colorful wallpapers for the background of the visual touch screen by pressing the relevant icon.

⑫ Reset All to Defaults

Press the Yes key to reset all the parameters to the original values (factory settings) except the language selection.

⑩

⑪

⑫

CUSTOMIZING EMBROIDERY MODE SETTINGS

Embroidery Mode Settings

Press the embroidery setting mode tab (refer to page 48).

① Auto thread tension

The auto thread tension level can be adjusted with the “+” or “-” key. Increase the value when using the same threads on the bobbin and needle.

② Low bobbin thread warning

The low bobbin thread warning level can be adjusted with the “+” or “-” key. To turn this option off, press the “-” key until “OFF” shows in the window.

Press the next page key to go to the next menu.

③ Maximum embroidery speed

The maximum embroidery sewing speed can be set from 400 to 860 spm in 100 spm intervals by pressing the “+” or “-” key.

④ One stitch stop

When this function is turned on, the machine sews one stitch and stops automatically so that you can bring the bobbin thread up before sewing.

⑤ Consecutive color grouping

If an imported design files of a pattern combination contain consecutive sections in the same color, these sections are automatically grouped together as one section when opening the file or going to the ready to sew window. This function is invalid when combining the built-in designs and externally sourced designs. Turn this option off if you do not wish to group the sections together.

⑥ Hoop confirmation

The hoop confirmation message will appear every time before opening the ready to sew window. However you can turn this option off by selecting off.

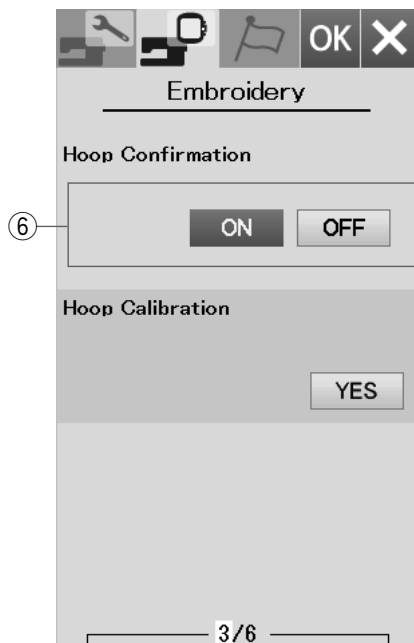
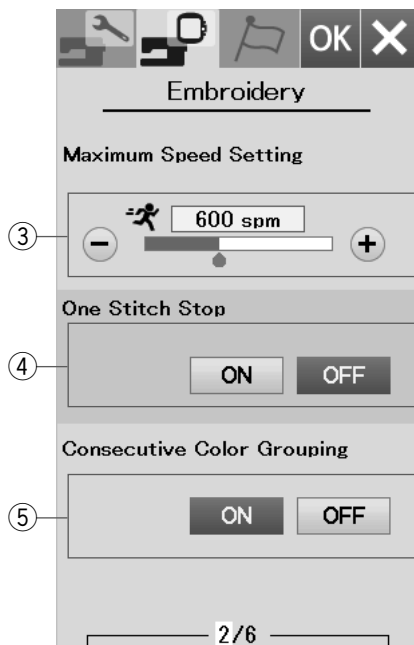
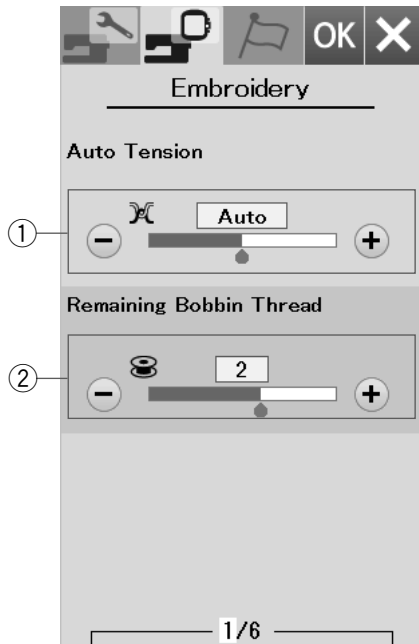

⑦ Hoop calibration

You can calibrate the center position of the hoops.
Press the Yes key.

⑦-1 Yes key

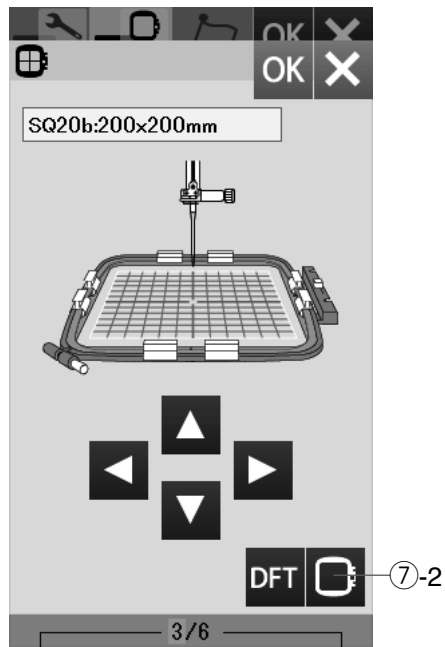
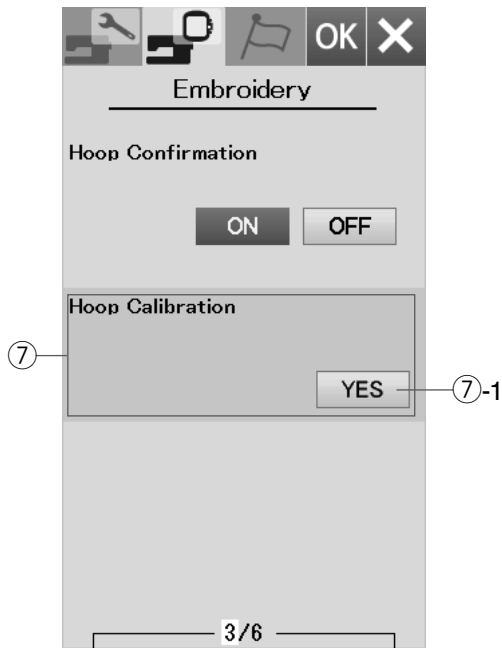

The carriage moves to the center position.

Press the hoop selection key to open the hoop selection window.

⑦-2 Hoop selection key

Select the hoop and attach it to the carriage. Set the template in the hoop.

Adjust the hoop position by pressing the jog keys so that the needle is right above the hole in the template and press the OK key.

Press the next page key to go to the next menu.

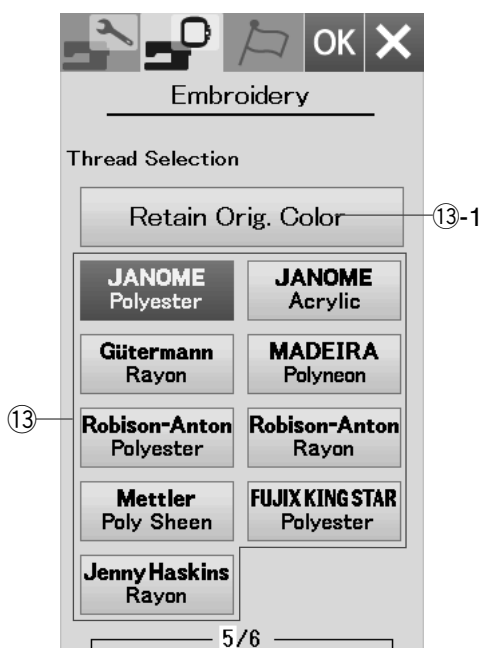
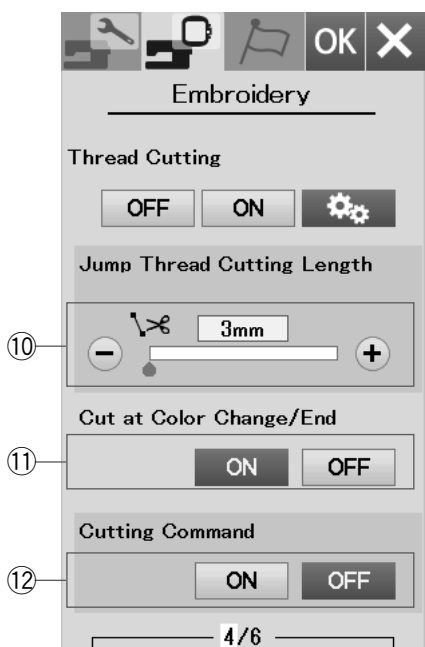
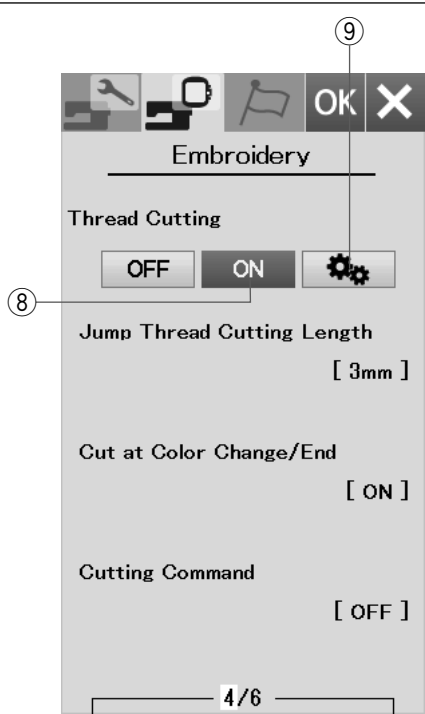

Thread cutting

⑧ Easy setting

When this setting is turned on, the machine will trim the threads if the jump thread is 3 mm or longer, or when the machine stops to change the thread to the next color. Press the OK key to confirm the easy setting.

⑨ Advanced setting

When this setting is turned on, you can configure the Jump thread cutting ⑩, Cut at color change/end ⑪, and Cutting Command ⑫ options individually. Press the OK key to confirm the advanced setting.

There are 3 thread cutting options for embroidery.

⑩ Jump thread cutting length

When this option is turned on, the machine trims the jump threads if the jump thread length is the same or more than the set value.

⑪ Cut at color change/end

When this option is turned on, the machine trim the thread when it stops to change the thread to the next color.

⑫ Cutting command

When this option is turned on, the machine trim the threads at the trim code if the imported stitch data file contains a trim command (cutting command).

⑬ Thread selection

There are 9 types of embroidery thread to choose from. Press the key of the thread you wish to use. The color code of the selected brand is shown on the list of thread colors along with the name of the color.

If you use imported embroidery stitch data containing proper thread information, press the retain original color key to retain this information.

⑬-1 Retain original color key

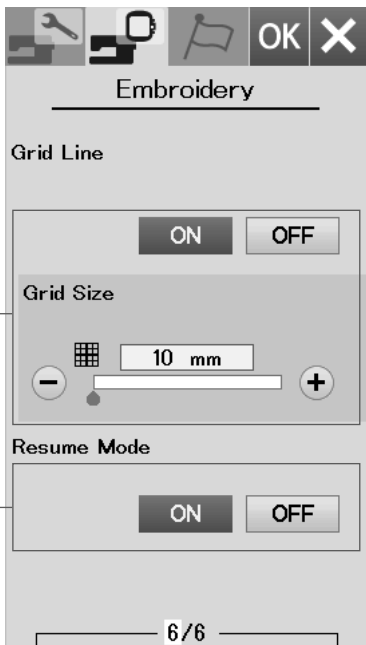

⑭

⑮

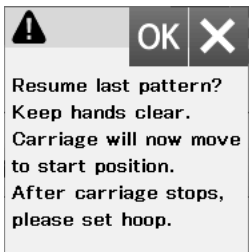

⑭ Grid line on/off

Turn this option on to show grid in the editing window. The grid size can be altered from 10 to 30 mm with the “+” or “-” key when this option is on. Turn this option off to hide the grid.

⑮ Resume mode

When Resume Mode is turned on, the last pattern sewn before turning the power off will resume when you turn the power on again.

When you turn the power on, the confirmation window opens. Press the OK key to resume the last pattern.

After customizing the settings, press the OK key to enable the new settings.

To exit the setting mode without changing the settings, press X key.



Language Selection Mode

Select the desired language and press the OK key. The visual touch screen shows messages in the selected language.

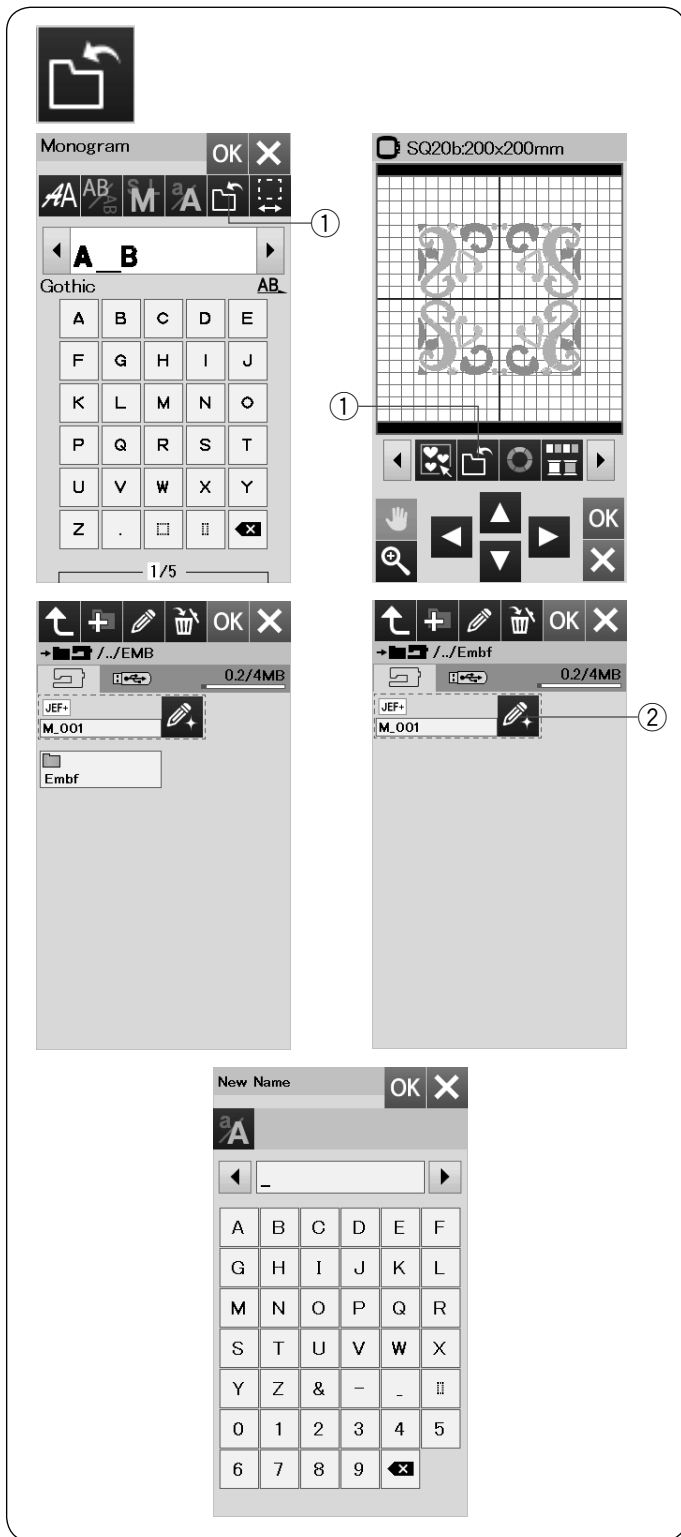

Saving and Opening a File

You can save original embroidery designs as files in the built-in memory and/or USB flash drive.

Press the save file key and the save file window will open.

- 1 Save file key

A folder labeled "Embf" is displayed on the screen. To select a folder, press the folder icon.

File names are assigned automatically in numerical order starting from M_001.....

Press the OK key and the file is saved in the selected folder.

To assign a particular name to the file, press the rename key.

- 2 Rename key

The keyboard window opens.

Enter a new name and press the OK key.

The file is saved under the new name.

When you attempt to save a file with a name that already exists, the confirmation message will appear.

Press the OK key to overwrite the existing file or press the X key if you do not want to overwrite it.

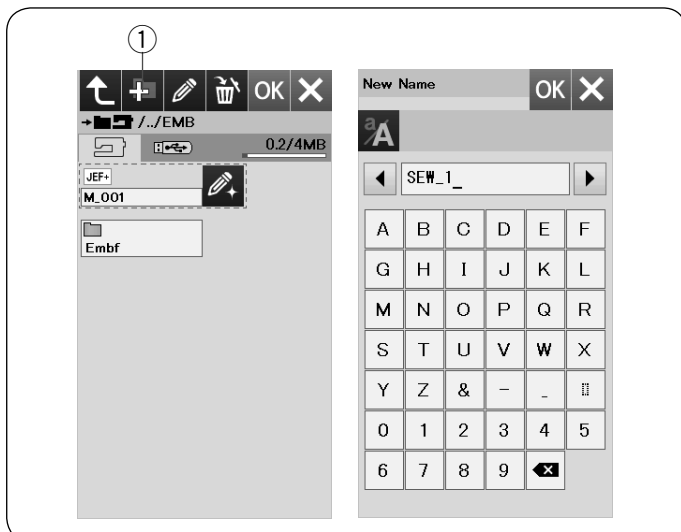

Creating a new folder

Press the new folder key and the keyboard window will open.

- 1 New folder key

Enter a folder name and press the OK key.

A new folder is created under the assigned name.

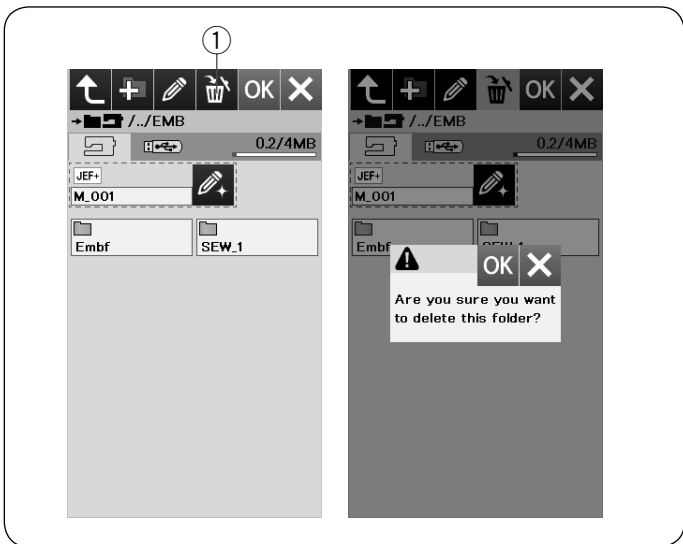

Deleting a file or folder

Press the delete key and select the file or folder to delete. A confirmation message appears.

Press the OK key to delete the file or folder.

- ① Delete key

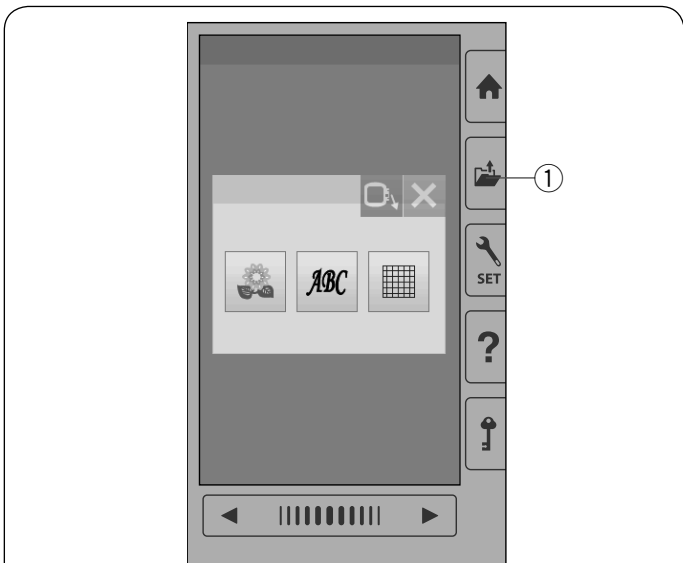

Opening a file

To open saved files, press the open file key to open the open file window.

- ① Open file key

Select the folder location, either the built-in memory or USB flash drive.

Open the folder that contains the desired file by pressing the folder icon.

The file list of the selected folder is displayed.

To open the file, press the file icon.

The file attributes can be shown on the file icon.

To show the file attribute, press the “large icon” key or “file list” key.

- ② Large icon key
- ③ File list key

There are 5 file attributes as follows:

JEF : *.JEF (Janome embroidery format)

JEF+ : *.JEF+ (editable Janome embroidery format)

JPX : *.JPX (*.JEF+ with a background bitmap image)

JPX : *.JPX (Acufil embroidery format)

DST : *.DST (Tajima embroidery format)

To hide file attribute, press the small icon key.

- ④ Small icon key

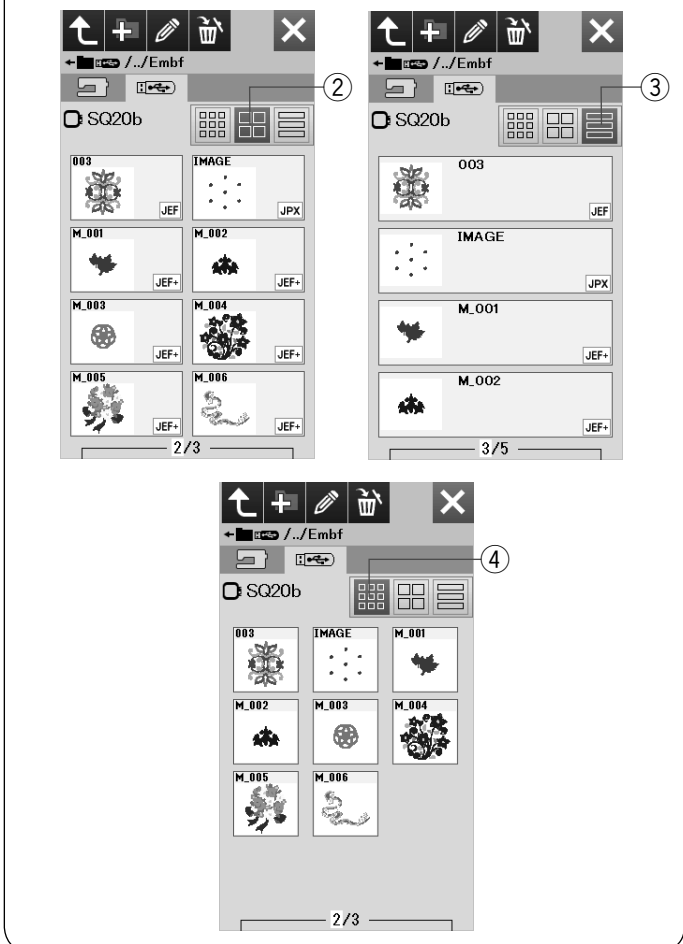

NOTE:

Tajima (*.DST) format does not have thread color information. Janome's thread color will be assigned automatically when opening.

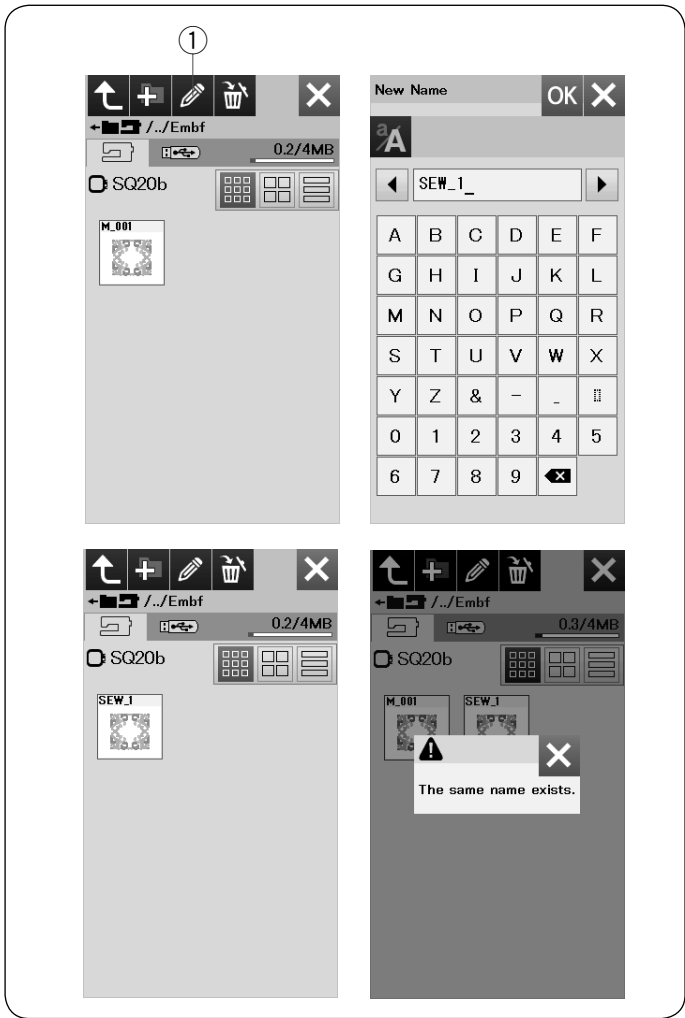

Changing a name of the file or folder

Press the rename key and select the file or folder for which you wish to change the name.
 The keyboard window will open.
 Enter a new name and press the OK key.
 The name of the file or folder will change.

① Rename key

If you enter a name that already exists, the message “The same name exists.” will appear.
 Press the X key and enter another name.

CARE AND MAINTENANCE

Cleaning the Hook Area

Clean the hook area at least once a month.

When the clean bobbin holder message option is turned on, the caution message for cleaning the bobbin case and the hook race will be displayed when the certain time passes (refer to page 50).

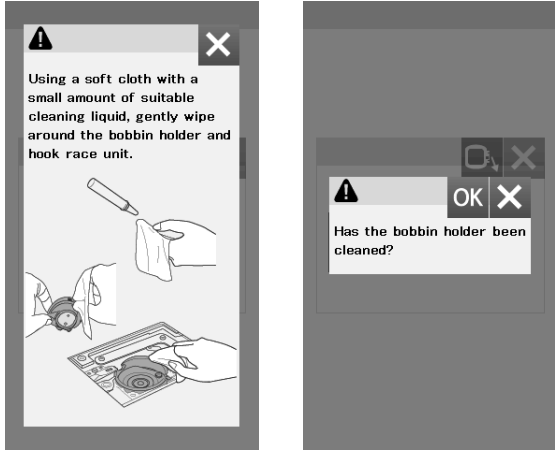

CAUTION:

Always make sure to turn the power switch off before cleaning the hook area.
Do not dismantle the machine in any way other than as explained in this section.

Turn the power switch off and unplug the machine.

Remove the needle plate by turning the setscrews with the screwdriver key.

Remove the needle and presser foot.

Take out the bobbin and bobbin holder.

- 1 Bobbin holder

Clean the bobbin holder with a lint brush.

Apply a few drops of the bobbin holder cleaner (included in the standard accessories) to a soft cloth and wipe the bobbin holder thoroughly both inside and outside.

- 2 Lint brush
- 3 Bobbin holder cleaner
- 4 Soft cloth

Clean the auto thread cutter device with the lint brush.

- 5 Auto thread cutter device

Clean the inside and lip of the hook race with a soft cloth.

Insert the bobbin holder so that the knob fits next to the stopper in the hook race.

Insert the bobbin.

- 6 Knob
- 7 Stopper

Attach the needle plate, presser foot and needle.

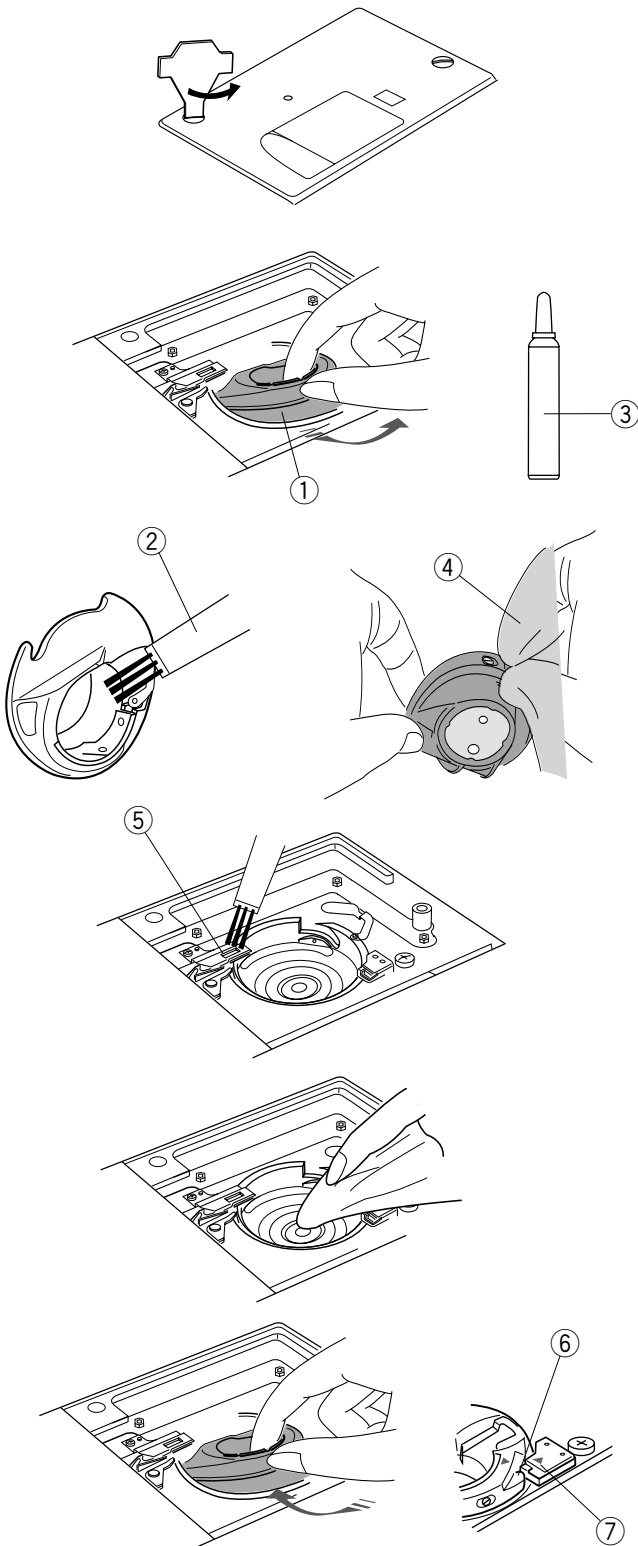

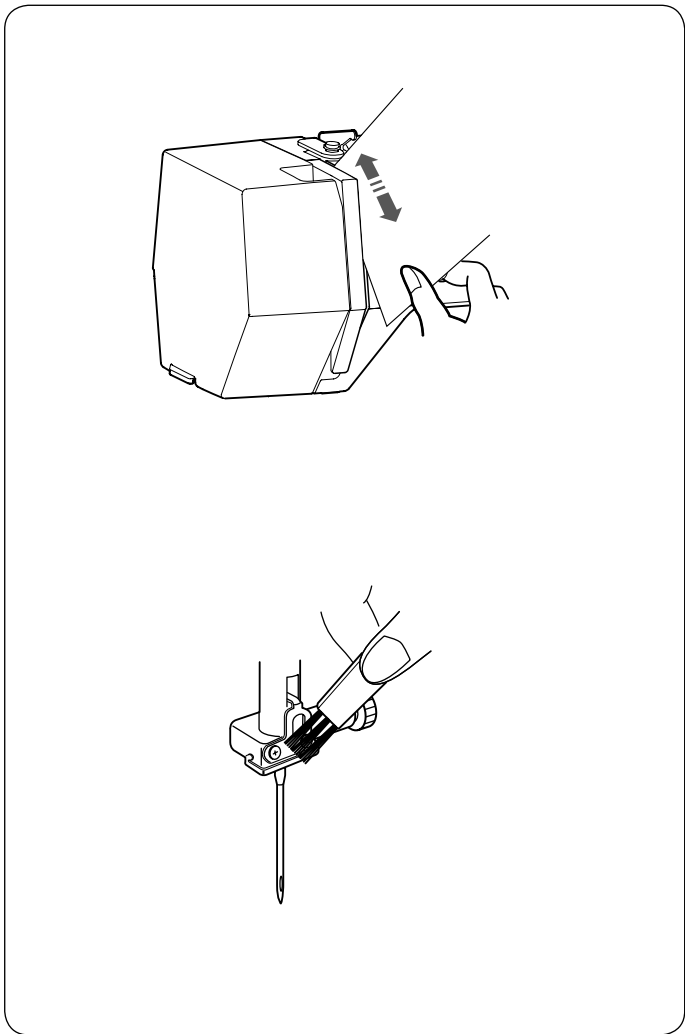

Cleaning the Thread Path

Clean lint and wax in the tension area with a piece of paper.

Insert a piece of paper along the right channel and scrape out lint.

Clean the needle bar thread guide with lint brush.

Oiling the Machine



WARNING:

Move the carriage to the home position (refer to page 31), and turn off the power switch and/or unplug the machine before oiling the machine.

Wait until the motor cools down before oiling.

Do not dismantle the machine in any way other than as explained in this section.

Do not oil any parts other than as explained in this section.

NOTE:

Oil the points as shown at least once a month if you are using the machine every day.

Use good quality sewing machine oil.

One or two drops of oil is sufficient.

Remove excess oil, otherwise it may stain fabric.

In case machine is not used for an extended time, oil it before sewing.

You need a phillips driver to attach/remove the covers or setscrews.

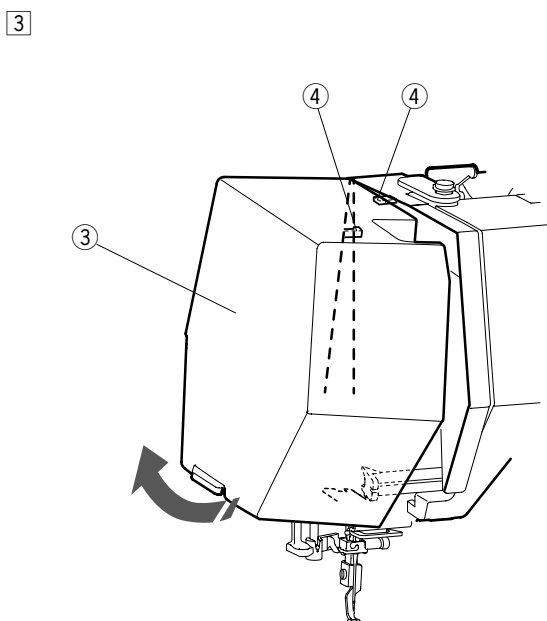
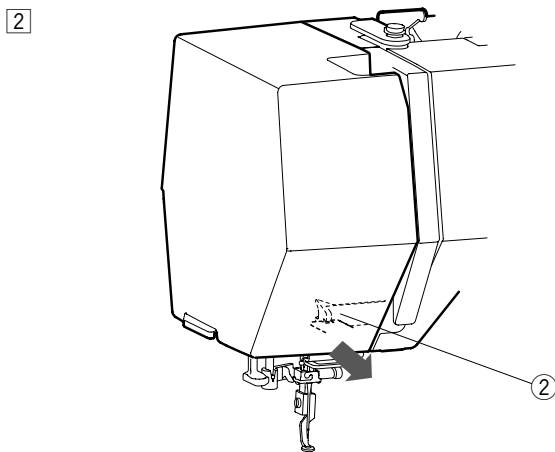
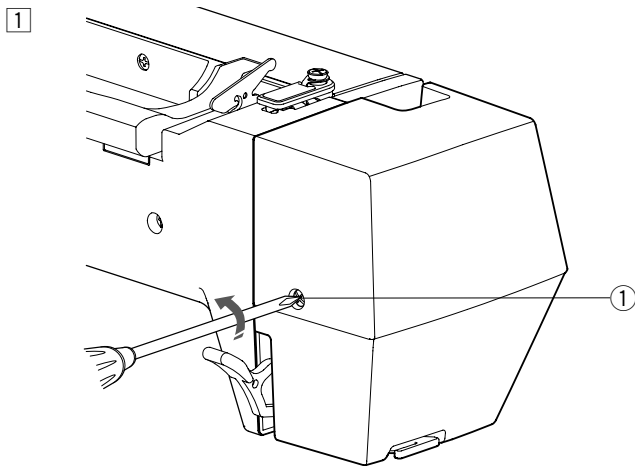

Oil the needle bar, presser bar and thread take-up lever

1 Remove the setscrew ①.

① Setscrew

2 Pull the face plate to unhook the front hook.

② Front hook

3 Tilt the face plate in the direction of arrow to unhook the rear hooks.

Remove the face plate.

③ Face plate

④ Rear hooks

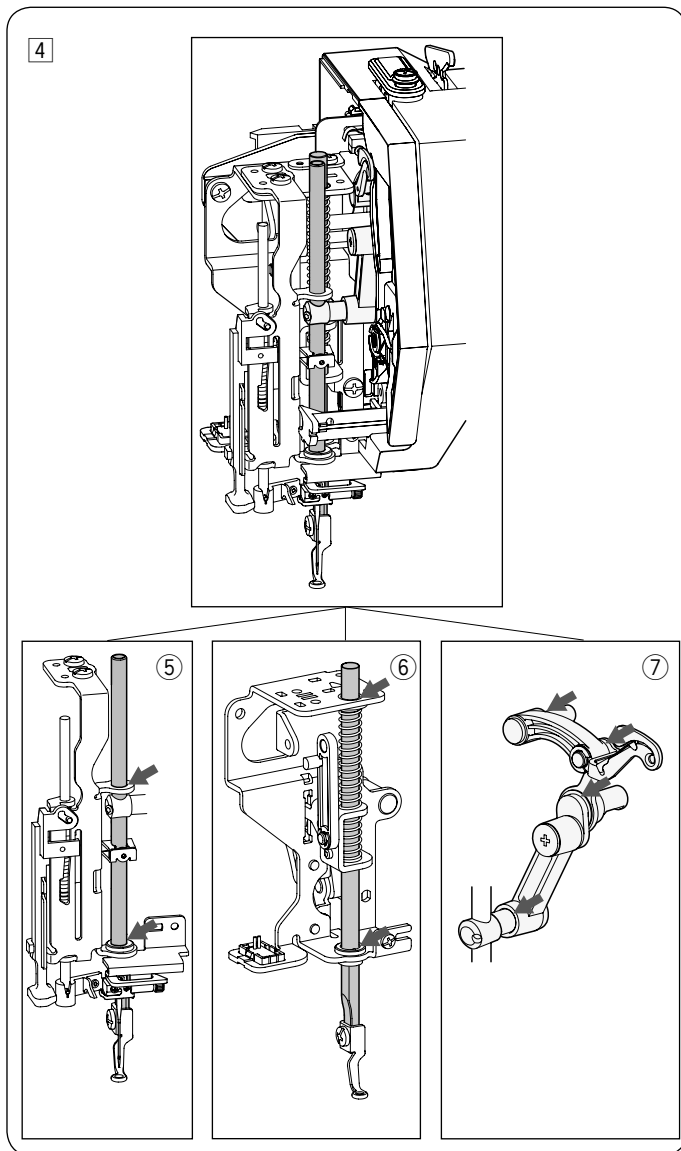

- 4 Oil the arrow points as indicated in the illustration.
- 5 Needle bar
 - 6 Presser bar
 - 7 Thread take-up lever

To attach the face plate, reverse the procedure 1 to 3 in reverse.

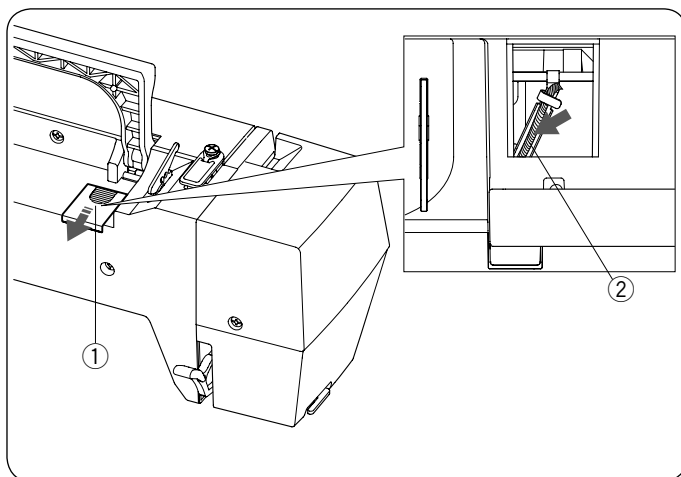

Oil the oil wick

Slide the cover 1 on the top rear side of the machine.
Oil the oil wick 2 inside of the machine.

- 1 Cover
- 2 Oil wick

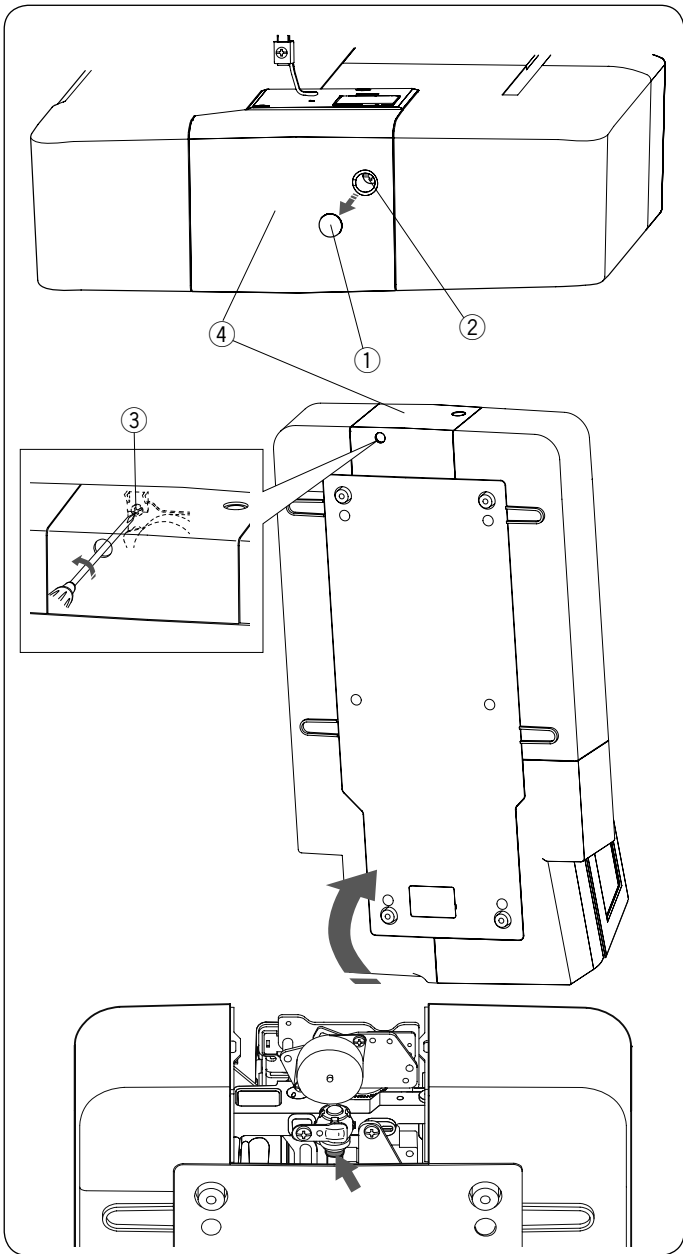

Oil the lower shaft supporter (front)

NOTE:

Be careful not to damage any parts when raise the machine.

Remove the cap ① and setscrew A ② with a screwdriver. Stand the machine so that the handwheel side comes to the underside of the machine.

Insert the screwdriver from the bottom hole of the thread cutter cover. Loosen the setscrew B ③. Remove the thread cutter cover ④.

- ① Cap
- ② Setscrew A
- ③ Setscrew B
- ④ Thread cutter cover

Oil the arrow point (felt) as indicated in the illustration.

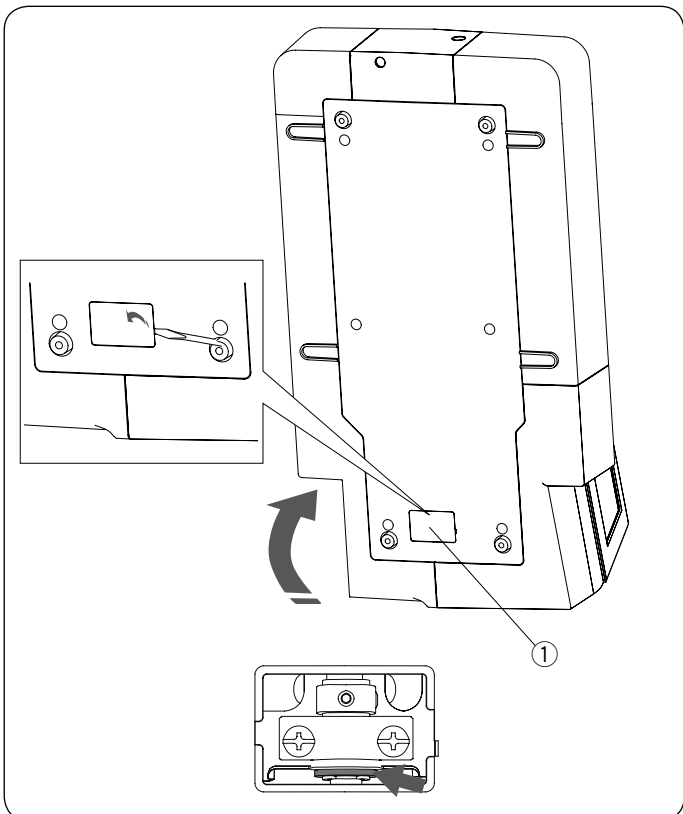

Oil the lower shaft supporter (rear)

NOTE:

Be careful not to damage any parts when raise the machine.

Stand the machine so that the handwheel side comes to the underside of the machine.

Remove the cover ① on the underside of the machine with a screwdriver.

- ① Cover

Oil the arrow point (felt) as indicated in the illustration.

1

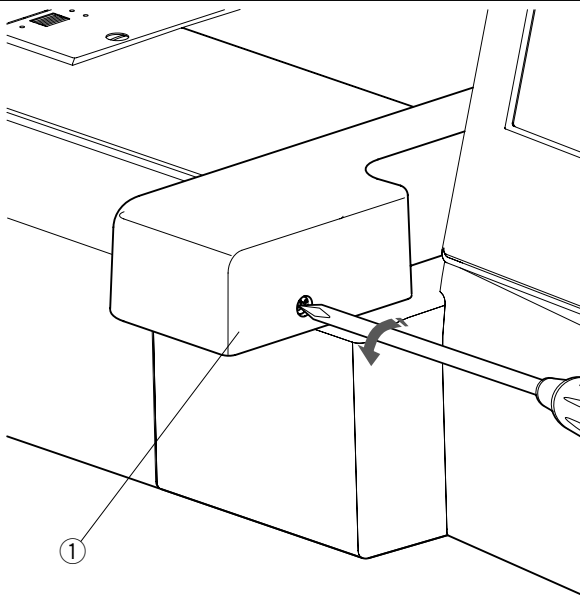

2

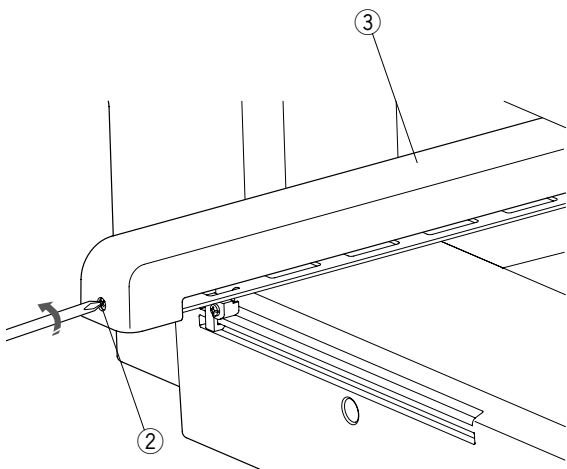

3

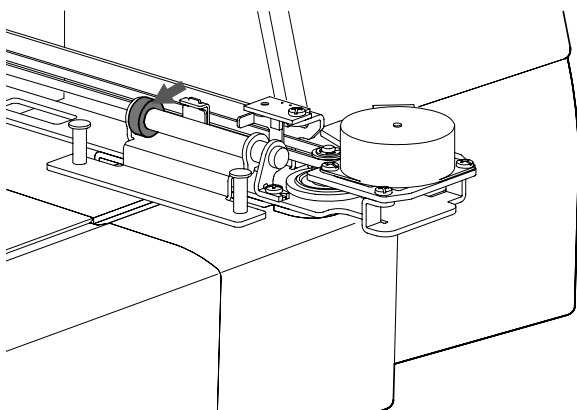

Oil the Y-carriage

1 Remove the setscrew ①.

① Setscrew

2 Remove the setscrew ②.

Remove the carriage cover ③.

② Setscrew

③ Carriage cover

3 Oil the arrow point (felt) as indicated in the illustration.

To attach the carriage cover, reverse the procedure 1 to 2 in reverse.

Oil the X-carriage

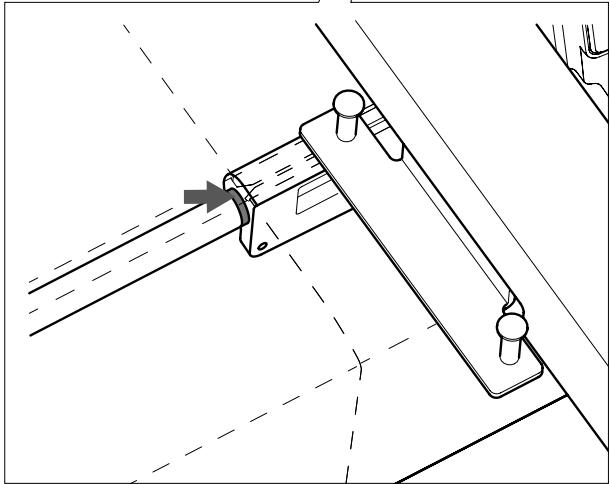
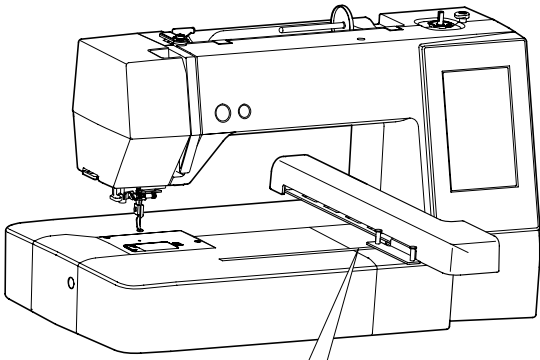

Oil the arrow point (felt) inside of the carriage slit.

Troubleshooting

Condition	Cause	Reference
The machine is noisy.	1. Thread is jammed in the hook area.	See page 58.
The needle thread breaks.	1. The needle thread is not threaded properly. 2. The needle thread tension is too tight. 3. The needle is bent or blunt. 4. The needle is inserted incorrectly. 5. The needle thread was not set in the thread holder when embroidery sewing started.	See page 11. See page 51. See page 13. See page 13. See page 20.
The bobbin thread breaks.	1. The bobbin thread is not threaded properly in the bobbin holder. 2. Lint has collected in the bobbin holder. 3. The bobbin is damaged and does not turn smoothly.	See page 10. See page 58. Replace the bobbin.
The needle breaks.	1. The needle is inserted incorrectly. 2. The needle is bent or blunt. 3. The needle clamp screw is loose.	See page 13. See page 13. See page 13.
Visual Touch Screen is not clear.	1. The contrast of the screen is not adjusted properly.	See page 49.
Skipped stitches	1. The needle is inserted incorrectly. 2. The needle is bent or blunt. 3. The needle thread is not threaded properly. 4. The needle is defective (rusted, burr on needle eye or tip). 5. The embroidery hoop is not set properly. 6. The fabric is not stretched tightly enough on the embroidery hoop. 7. A stabilizer is not being used. 8. The thread coming out from the needle eye is too short after auto thread cutting.	See page 13. See page 13. See page 11. Change the needle. See page 19. See page 18. See page 17. See page 11.
The machine does not run.	1. Thread is jammed in the hook area. 2. The machine is not plugged in.	See page 58. See pages 6.
Abnormal noise occurs when the machine is switched on.	1. Something is caught between the carriage and the arm.	Remove the object.
The patterns are distorted.	1. The fabric is not pulled tightly on the embroidery hoop. 2. The embroidery hoop is not fixed securely. 3. The carriage is bumping into something around the machine. 4. The fabric is caught or pulled for some reason when sewing embroidery. 5. A stabilizer is not used.	See page 18. See page 19. Do not place any obstacle around the machine. Reattach the fabric. See page 17
Function keys do not work.	1. Key positions are not adjusted properly. 2. The control circuit is not working correctly. 3. The bobbin winder spindle is in the winding position.	See page 49. Contact the service center or the store. See page 9.
USB flash drive does not work.	1. The USB flash drive is not inserted correctly. 2. The USB flash drive is damaged.	Insert the USB flash drive properly. Replace or format the USB flash drive.

It is not abnormal for a faint humming sound to be heard from the internal motors.

The visual touch screen and function key area may become warm after several hours of continuous use.

