



Instruction Manual
Analog Multi-Tube Vortexer
Digital Multi-Tube Vortexer



TABLE OF CONTENTS

Package Contents	1
Warranty	1
Installation	2
Maintenance & Servicing	2
Environmental Conditions	2
Safety Instructions	3
Standards & Regulations	3
Specifications - Analog	4
Operating Instructions - Analog	5
Specifications - Digital	6
Control Panel - Digital	7
Operating Instructions - Digital	8-9
Replacement Parts	10
Accessories	11

PACKAGE CONTENTS

Multi Tube Vortexer
12mm test tube foam rack
Tray pad set (top & lower pad)
92" (234cm) detachable power cord
Instruction manual

WARRANTY

Manufacturer warrants this product to be free from defects in material and workmanship when used under normal conditions for five (5) years. Register your equipment or instrument online at www.vwrsp.com/warranty for US residents and www.vwrcanlab.com/warranty for Canadian residents. For your reference, make a note of the serial number, date of purchase and supplier here.

Serial Number: _____

Date of Purchase: _____

Supplier: _____

INSTALLATION

Upon receiving the VWR Multi-Tube Vortexer, check to ensure that no damage has occurred in shipment. It is important that any damage that occurred in transport is detected at the time of unpacking. If you do find such damage the carrier must be notified immediately.

After unpacking, place the Multi-Tube Vortexer on a level bench or table, away from explosive vapors. Ensure that the surface on which the unit is placed will withstand typical heat produced by the unit and place the unit a minimum of six (6) inches from vertical surfaces. Always place the unit on a sturdy work surface. Position the unit in such a way that it is easy to reach and unplug the power cord from the back of the unit.

The Multi-Tube Vortexer is supplied with a power cord that is inserted into the IEC connector on the back of the unit first, then it can be plugged into a properly grounded outlet. The 120V unit plugs into a 120 volt, 50/60 Hz source. The 230V unit plugs into a 230 volt, 50/60 Hz source. DO NOT replace the cord with an inadequately rated main supply cord.

MAINTENANCE & SERVICING

The Multi-Tube Vortexer is built for long, trouble-free, dependable service. No lubrication or other technical user maintenance is required. It needs no user maintenance beyond keeping the surfaces clean.

The unit should be given the care normally required for any electrical appliance. Avoid wetting or unnecessary exposure to fumes. Spills should be removed promptly. **DO NOT** use a cleaning agent or solvent on the front panel which is abrasive or harmful to plastics, nor one which is flammable. Always ensure the power is disconnected from the unit prior to any cleaning. If the unit ever requires service, contact your VWR representative.

INTENDED USE

The VWR Multi-Tube Vortex Mixers are intended for general laboratory use. Safety can not be guaranteed if used outside of the intended use.

ENVIRONMENTAL CONDITIONS

Operating Conditions: Indoor use only.

Temperature:	4 to 40°C (39 to 104°F).
Humidity:	20% to 85% relative humidity, non-condensing
Altitude:	0 to 6,562 ft (2000 M) above sea level

Non-Operating Storage:

Temperature:	-20 to 65°C (-4 to 149°F)
Humidity:	20% to 85% relative humidity, non-condensing

Installation Category II and Pollution Degree 2 in accordance with IEC 664.

SAFETY INSTRUCTIONS

Please read the entire instruction manual before operating the Multi-Tube Vortexer.



WARNING! DO NOT use the Multi-Tube Vortexer in a hazardous atmosphere or with hazardous materials for which the unit was not designed. Also, the user should be aware that the protection provided by the equipment may be impaired if used with accessories not provided or recommended by the manufacturer, or used in a manner not specified by the manufacturer.

Always operate unit on a level surface for best performance and maximum safety.

DO NOT lift the Multi-Tube Vortexer by the support plate or bottom tray. The support plate is removable.



CAUTION! To avoid electrical shock, completely cut off power to the unit by disconnecting the power cord from the unit or unplug from the wall outlet. Disconnect unit from the power supply prior to maintenance and servicing.

Spills should be removed promptly. **DO NOT** immerse the unit for cleaning.

DO NOT operate the unit if it shows signs of electrical or mechanical damage.



Earth Ground - Protective Conductor Terminal

Alternating Current

STANDARDS & REGULATIONS

Troemner, LLC hereby declares under its sole responsibility that the construction of this product conforms in accordance with the following standards:

Associated EU guidelines:

EMC directive 2014/30/EU

LVD directive 2014/35/EU

RoHS directive 2011/65/EU

Safety standards:

CAN/CSA C22.2 No. 61010-1:2012-05

UL 61010-1:2012-05

EN 61010-1:2010-10

CAN/CSA C22.2 No. 61010-2-051:2015-10

EN 61010-2-051:2015-04

EMC standards:

IEC/EN 61326-1: Electrical equipment for measurement, control and laboratory use -

EMC requirements - Part 1: General requirements

IEC 61000-4-2

IEC 61000-4-3

IEC 61000-4-4

IEC 61000-4-5

IEC 61000-4-6

IEC 61000-4-8

IEC 61000-4-11

IEC 61000-3-2

IEC 61000-3-3

CISPR 11

SPECIFICATIONS - ANALOG MULTI-TUBE VORTEXER

Overall dimensions (L x W x H):	9.5 x 15.1 x 16" (24.1 x 38.4 x 40.6cm)
Electrical (50/60 Hz):	120V - 0.8 amps, 100 watts 230V - 0.4 amps, 100 watts
Fuses:	120V - 5mm x 20mm, 5 amp, 250V quick acting 230V - 5mm x 20mm, 5 amp, 250V quick acting
Speed range:	1200 to 2400rpm
Accuracy:	+/- 25rpm
Orbit:	3.6mm
Weight capacity:	10lbs (4.5kg)
Timer:	mechanical timer runs 0 to 60 seconds
Controls:	rocker switch: run, standby, timer, speed knob, variable 1 to 10 dial markings, time knob, variable 1 to 10 dial markings
Ship weight:	45lbs (20.4kg)

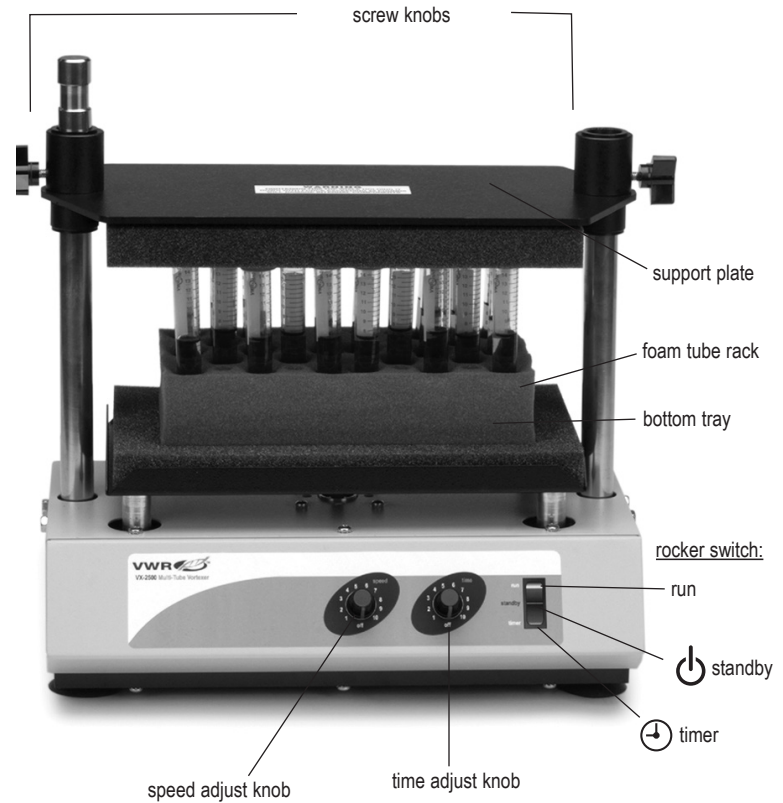

OPERATING INSTRUCTIONS - ANALOG MULTI-TUBE VORTEXER

The Multi-Tube Vortexer is used to prepare samples by mixing tubes just prior to testing.

IMPORTANT: This unit is designed for intermittent use only. **DO NOT** operate this unit for more than two hours at any one time.

IMPORTANT: In the event of a power outage or hazard that will interrupt unit operation, the unit will restart as set speed when a power outage or hazard is restored.

Getting ready:

- a. The speed and time knobs have a built-in on/off switch at the extreme counter-clockwise position. Turn the speed and time knobs to the off position.
- b. Press the rocker switch to the standby position, in the center.
- c. Plug the power cord into a properly grounded outlet.

2. Loading bottom tray:

- a. Loosen both screw knobs on the support plate. Lift the plate up. The screw knobs may be tightened to hold it in place, or if desired it may be swung out of the way. To do this, lift until the plate comes off the short right post and the left knob is up into the circular groove around the top of the left post. Screw the left screw knob in the circular groove but not quite tight. In this condition the support plate may be swung around the left post and out of the way.
- b. Fill the tubes to be vortexed and place them in the correct size test tube foam rack. Best results will be obtained if all tubes are filled to the same level, and not exceeding half of the tube capacity. Distribute tubes uniformly throughout the test tube foam rack. Always be sure that a tube is in each of the four corner holes on the test tube foam rack to properly hold the support plate. Empty tubes may be used for this purpose.
- c. Lower the support plate onto both posts and down on top of the tubes. Let the support plates weight rest on the tubes but **DO NOT** press down. Tighten both screw knobs securely.

3. Setting speed:

- a. Turn the speed knob clockwise to the 1 position.
- b. Press the rocker switch up to the continuous run position. The Multi-Tube Vortexer will start.
- c. Increase the speed by turning the speed knob clockwise until the desired speed is reached. Always use the slowest suitable speed.
- d. To stop vortexing, press the rocker switch to the standby position, in the center.

4. Setting time:

- a. For automatic timed operation, adjust the speed as in step 3, then set the time knob to the desired time, clockwise to increase and counter-clockwise to decrease time.
- b. Press the rocker switch briefly to the timer position, downward, and release. The Multi-Tube Vortexer will run for the selected time and shut off automatically.
- c. To repeat for the same time, simply press the timer switch again. To interrupt an automatic timing cycle before it is complete, turn the time knob to off, extreme counter-clockwise position. 

When operating the Multi-Tube Vortexer, use the rocker switch to start and stop operations, leaving the speed knob on. When the unit is not being used turn the speed knob to off, extreme counter-clockwise position.

SPECIFICATIONS - DIGITAL MULTI-TUBE VORTEXER

Overall dimensions (L x W x H):	9.5 x 15.1 x 16" (24.1 x 38.4 x 40.6cm)
Electrical (50/60 Hz):	120V - 0.8 amps, 100 watts 230V - 0.4 amps, 100 watts
Fuses:	120V - 5mm x 20mm, 5 amp, 250V quick acting 230V - 5mm x 20mm, 5 amp, 250V quick acting
Speed range:	500 to 2500rpm
Accuracy:	+/- 25rpm
Orbit:	3.6mm
Weight capacity:	10lbs (4.5kg)
Timer:	digital, 1 second to 9999 minutes (increased in 1 second increments)
Controls:	see page 7
Ship weight:	45lbs (20.4kg)

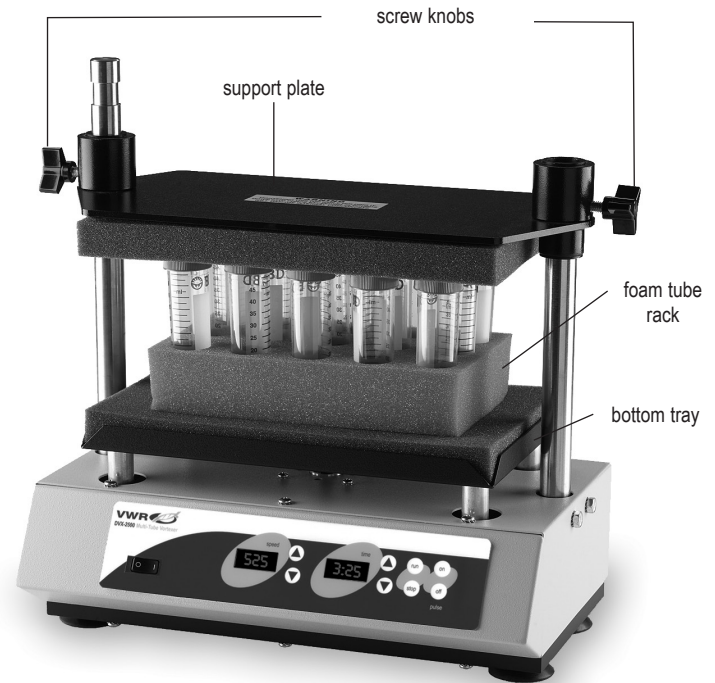

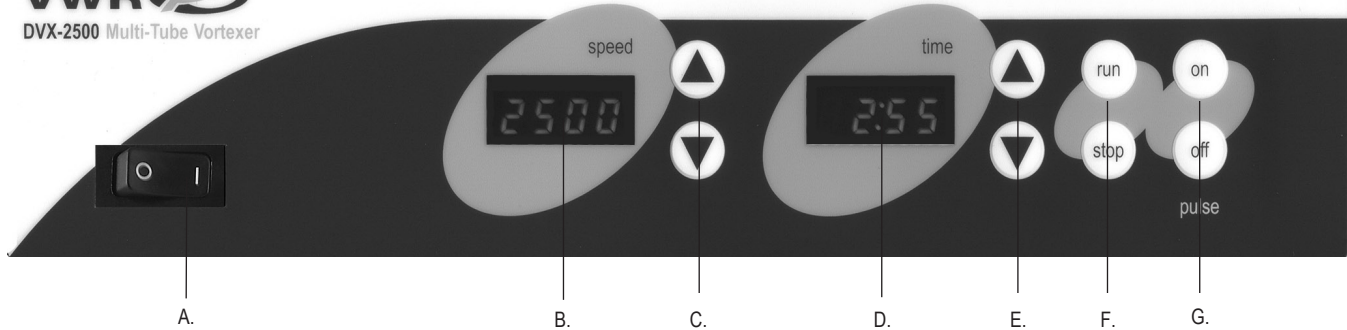

CONTROL PANEL - DIGITAL MULTI-TUBE VORTEXER

The front panel of the Multi-Tube Vortexer contains all the switches, controls and displays needed to operate the unit.

- A. On/off rocker switch:** Turns main power on/off.
- B. Speed display:** Displays the speed of the vortexer.
- C. Up/down arrows:** for set-point control.
- D. Time display:** Displays accumulated time (continuous mode) or how much time is remaining (timed mode). The display range is from 0 to 9,999 minutes in one (1) second increments. The display will indicate minutes and seconds until the timer reaches 99 minutes and 59 seconds (99:59), then the display will automatically display minutes up to 9,999.

- E. Up/down arrows for set-point control.**
- F. Run/stop buttons:** Activates vortexing.
- G. Pulse on/off buttons:** Activates pulse mode.

OPERATING INSTRUCTIONS - DIGITAL MULTI-TUBE VORTEXER

The Multi-Tube Vortexer is used to prepare samples by mixing tubes just prior to testing.

IMPORTANT: This unit is designed for intermittent use only. **DO NOT** operate this unit for more than two hours at any one time.

IMPORTANT: In the event of a power outage or hazard that will interrupt unit operation, the unit will restart as set speed when a power outage or hazard is restored.

1. Getting ready:

- By sure the rocker switch is in the off position, depressed to the right.
- Plug the power cord into a properly grounded outlet.
- Press the rocker switch to the on position, depressed to the left. The speed and time displays will illuminate.

2. Loading bottom tray:

- Loosen both screw knobs on the support plate. Lift the plate up. The screw knobs may be tightened to hold it in place, or if desired it may be swung out of the way. To do this, lift until the plate comes off the short right post and the left knob is up into the circular groove around the top of the left post. Screw the left screw knob in the circular groove but not quite tight. In this condition the support plate may be swung around the left post and out of the way.
- Fill the tubes to be vortexed and place them in the correct size test tube foam rack. Best results will be obtained if all tubes are filled to the same level, and not exceeding half of the tube capacity. Distribute tubes uniformly throughout the test tube foam rack. Always be sure that a tube is in each of the four corner holes on the test tube foam rack to properly hold the support plate. Empty tubes may be used for this purpose.
- Lower the support plate onto both posts and down on top of the tubes. Let the support plates weight rest on the tubes but **DO NOT** press down. Tighten both screw knobs securely.

3. Setting speed:

Press the up/down arrows to the right of the speed display until you reach the desired speed.

4. Setting timed mode:

To run in timed mode, press the up/down arrows to the right of the time display until you reach

the desired time. Press the run button. The unit will run for the programmed time. Time LED will display time remaining.

5. Setting continuous mode:

To run in continuous mode, set the time to zero (0) using the up/down arrows to the right of the time display. Press the run button and the unit will run until you press the stop button. Time LED will display accumulated time.

6. Setting pulse mode:

- Make sure the unit is not running.
- Press the on button above the word pulse. The unit must be stopped before pressing the pulse-on button.
- To stop the pulse feature press the off button above the word pulse. Pulse mode is factory programmed for 2 seconds on, 1 second off. The pulse-on and pulse-off times can be adjusted between 1 and 59 seconds in 1 second intervals.

7. Reprogram the pulse-on and/or pulse-off time as follows:

Pulse-on time

- Press rocker switch to the off position, to the right.
- Press rocker switch to the on position, to the left, while holding pulse-on button. The LED display for speed displays current pulse-on time. The pulse-on button can be released if necessary once the display is illuminated.
- Change the pulse-on time using the up/down arrows to the right of the speed display.
- When the rocker is pressed off, the value on the speed display is stored as the new pulse-on time.

Pulse-off time

- Press rocker switch to the off position, to the right.
- Press rocker switch to the on position, to the left, while holding pulse-off button. The LED display for time displays current pulse-off time. The pulse-off button can be released if necessary once the display is illuminated.
- Change the pulse-off time using the up/down arrows to the right of the time display.
- When the rocker is pressed off, the value on the time display is stored as the new pulse-off time.

REPLACEMENT PARTS - ANALOG MULTI-TUBE VORTEXER

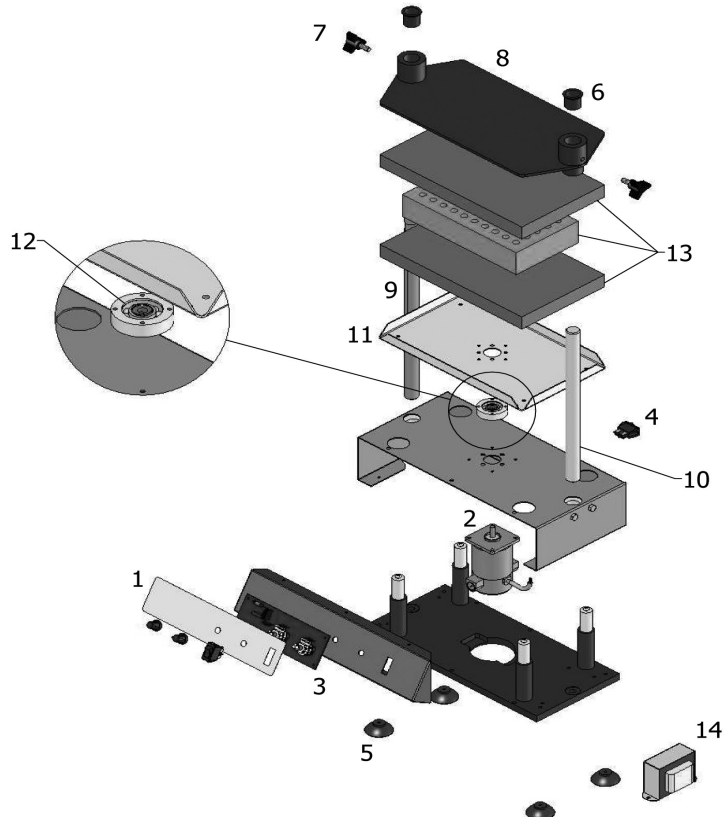

DESCRIPTION	PART NUMBER
1. Front panel	545025-00
2. DC motor	380006-00
3. DC circuit board	345101-00
4. Rocker switch, 120 volt	349025-00
Rocker switch, 230 volt	380008-00
5. Foot	545014-00
6. Sleeve	145034-00
7. Screw knob	545036-00
8. Support plate assembly	845001-00
9. Support post, 15.25" (38.7cm)	445038-00
10. Support post, 12.31" (31.3cm)	445039-00
11. Bottom tray	245025-00
12. Bearing	145027-00
Bearing holder	445026-00
13. Foam Pad	545030-00
Blue Foam Rack	545053-02
14. Transformer	380700-00

REPLACEMENT PARTS - DIGITAL MULTI-TUBE VORTEXER

DESCRIPTION	PART NUMBER
1. Front panel	545007-00
2. DC motor	380006-00
3. DC circuit board	345102-00
4. Rocker switch	380008-00
5. Foot	545014-00
6. Sleeve	145034-00
7. Screw knob	545036-00
8. Support plate assembly	845001-00
9. Support post, 15.25" (38.7cm)	445038-00
10. Support post, 12.31" (31.3cm)	445039-00
11. Bottom tray	245025-00
12. Bearing	145027-00
Bearing holder	445026-00
13. Blue foam rack	545053-02
Foam pad	545030-00
14. Transformer	380700-00

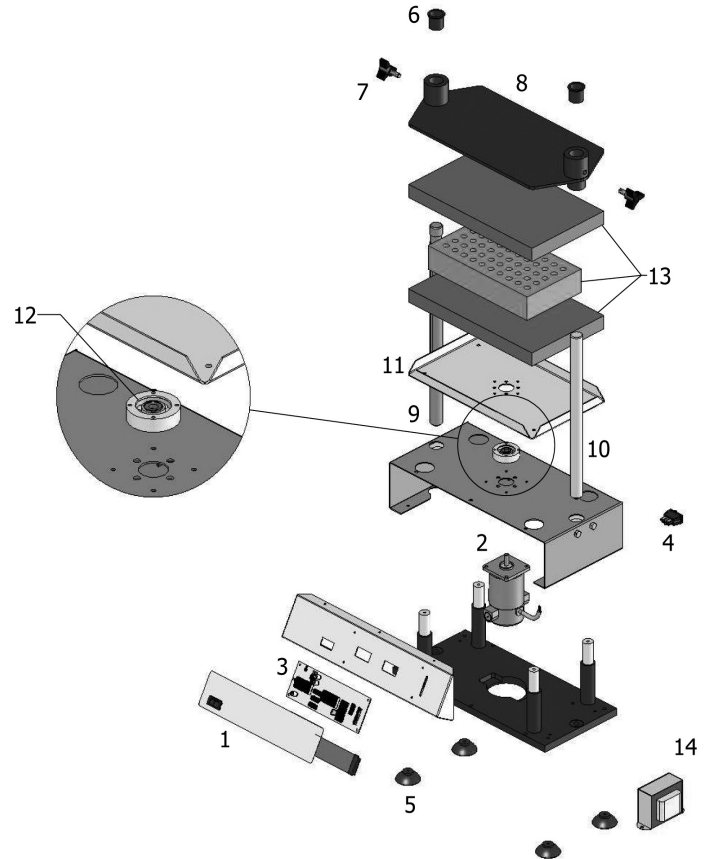

ACCESSORIES

Description	Tube Capacity	Color	Part Number
10mm test tube foam rack	50	gray	58816-308
12mm test tube foam rack	50	blue	58816-33
13mm test tube foam rack	50	yellow	58816-363
25mm test tube foam rack	17	white	12621-140
15mL centrifuge tube foam rack	50	green	58816-396
50mL centrifuge tube foam rack	17	red	12621-142
Replacement tray pad set (top & lower pad)	N/A	gray	58816-306
Post extension kit	N/A	N/A	14216-210

MANUFACTURED BY:

TROEMNER, LLC

201 Wolf Drive • PO Box 87 • Thorofare, NJ 08086-0087
Phone: 856-686-1600 • Fax: 856-686-1601 • E-mail: troemner@troemner.com
www.troemner.com
545046-00 (REV 8 8/16)