

Operator's Manual

For Veterinary Use Only

Customer and Technical Support:

1-800-822-2947

Available 24 hours a day, 7 days a week.

March 2013

**Abaxis, VetScan, VetScan VS2,
and iQC are registered trademarks
of Abaxis.**

**The information in this manual is
relevant to analyzers P/N 1200-1001
and 1200-1001R. Analyzers
1200-1001 and 1200-1001R report to
catalog numbers 1200-0000,
1200-0000E, 1200-0000R,
and 1200-0000ER.**

**U.S. Patent Nos. 5,061,381, 5,275,016,
5,304,348, 5,403,415, 5,413,732,
5,457,053**

**©2013, Abaxis, Inc.
Union City, CA
94587**

Table of Contents

Section 1: Quick Reference Guide	1-1
1.1 Analyzer Overview	1-1
1.2 Installation Guidelines	1-2
1.3 Guidelines for Obtaining and Using Samples	1-4
Section 2: General Information	2-1
2.1 Intended Use	2-1
2.2 Introducing the VetScan VS2	2-1
2.3 Abaxis Technical Support	2-2
2.4 Symbols Used in Labeling	2-2
2.5 Frequently Asked Questions	2-3
Section 3: Set Up and Analyzer Description	3-1
3.1 Unpacking the Analyzer	3-1
3.2 Setting Up the Analyzer	3-2
3.3 Analyzer and Environmental Specifications	3-5
3.4 VetScan VS2 Chemistry Analyzer Overview	3-5
3.5 Reagent Rotors	3-7
Section 4: Test Procedure and Results	4-1
4.1 Introduction to Testing	4-1
4.2 Collecting Samples	4-2
4.3 Adding a Sample to the Rotor	4-3
4.4 Running Tests	4-4
4.5 Canceling an Analysis	4-12
4.6 Using Test Results	4-13
4.7 Test Procedure Summary	4-14
Section 5: Configuring the Analyzer	5-1
5.1 Using the Settings Screens	5-2
5.2 Customizing Reference Ranges	5-2
5.3 Printing and Archiving Reference Ranges	5-10
5.4 Retrieving Reference Ranges	5-11
5.5 Transmitting Reference Ranges	5-12
5.6 Viewing Analyzer Identification	5-13
5.7 Changing Date and Time	5-14
5.8 Selecting the Language	5-15
5.9 Selecting Units	5-16
5.10 Setting Sound Volumes	5-21
5.11 Adjusting the Display	5-22
5.12 Configuring Printers	5-24
5.13 Setting Communication Protocol	5-27
5.14 Setting Optional Advanced Functions	5-28

Section 6: Recalling Results	6-1
6.1 Recalling the Last Rotor Results	6-2
6.2 Searching Results	6-3
6.3 Browsing Results	6-7
6.4 Transmitting Results	6-9
Section 7: Calibration and Quality Control	7-1
7.1 Calibration	7-1
7.2 Quality Control Features	7-1
7.3 Running Controls	7-3
Section 8: Troubleshooting	8-1
8.1 Using Analyzer Messages	8-1
8.2 Contacting Abaxis Technical Support	8-1
8.3 Instrument and Result Messages	8-1
8.4 Rotor Cancellations and Procedures	8-3
8.5 Reinitializing the Analyzer	8-3
Section 9: Principles of Procedure and Operation	9-1
9.1 Principles of Procedure	9-1
9.2 Principles of Operation	9-2
Section 10: Maintenance and Service	10-1
10.1 Cleaning the Analyzer	10-1
10.2 Cleaning Spills	10-2
10.3 Cleaning the Air Filter	10-2
10.4 Updating the Analyzer Software	10-3
10.5 Returning the Analyzer for Service	10-4
Section 11: Connecting to an External Computer	11-1
11.1 Transmission Specifications	11-2
11.2 Enabling the VetScan VS2 Communication Protocol	11-2
11.3 Installing the Windows Driver	11-3
11.4 Installing the Windows Vista Driver	11-7
11.5 Installing the Mac OS X Driver	11-11
11.6 Installing the Linux Driver	11-13
11.7 Using HyperTerminal	11-14
Section 12: Ordering Information	12-1
12.1 Required Materials	12-1
12.2 Ordering Information	12-1
12.3 VetScan Reagent Rotors	12-2
12.4 Optional Materials	12-2
Section A: iQC Codes	A-1
Section B: Supported Printers	B-1
Section C: Methods Performance	C-1
Section D: Species Labels	D-1
Index	I-1

Quick Reference Guide

1.1 Analyzer Overview

These figures show the VetScan VS2 Analyzer and its components.

1.1.1 Front and Back Views

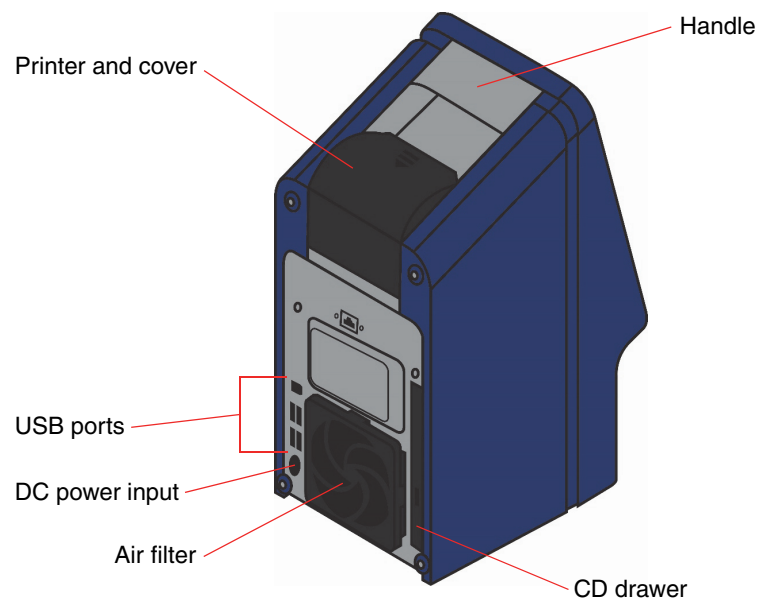
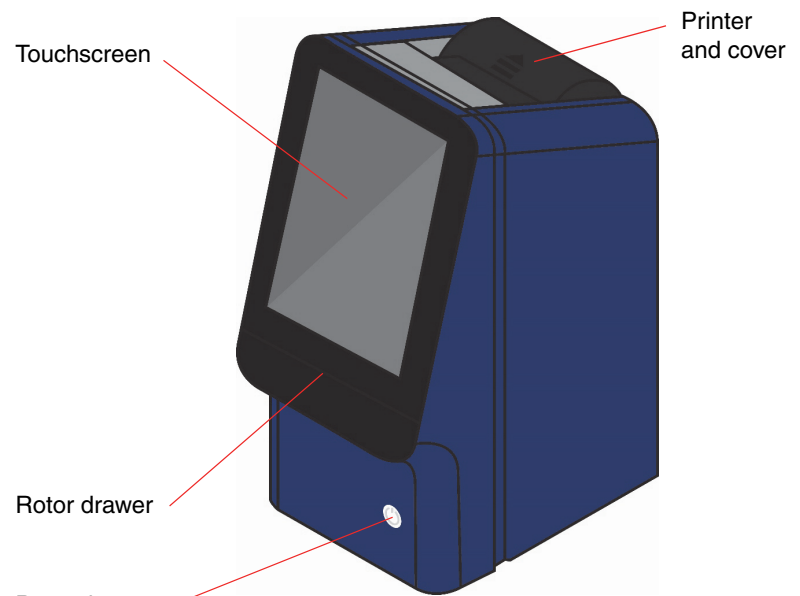

1.2 Installation Guidelines

1.2.1 Step 1: Unpack Analyzer and Accessories

1. Immediately upon receipt, place the box of reagent rotors in a refrigerator (2–8 °C or 36–46 °F).
2. Remove the analyzer from its box and place it on a stable, level surface.
3. Complete and mail the warranty card within 10 days of installing the system.

Note: *This Operator's Manual is the most complete reference for the analyzer. Always refer to this manual. Keep this manual in a convenient location for easy access, and store all product and manual updates in it.*

1.2.2 Step 2: Set Up Electrical Connections

1. Attach the AC power cord (with electrical wall plug) to the analyzer's power adapter (see the figure).
2. Attach the DC power cord to the back of the analyzer.
3. Plug the AC power cord into a grounded electrical outlet.
4. Make sure all connections are secure.

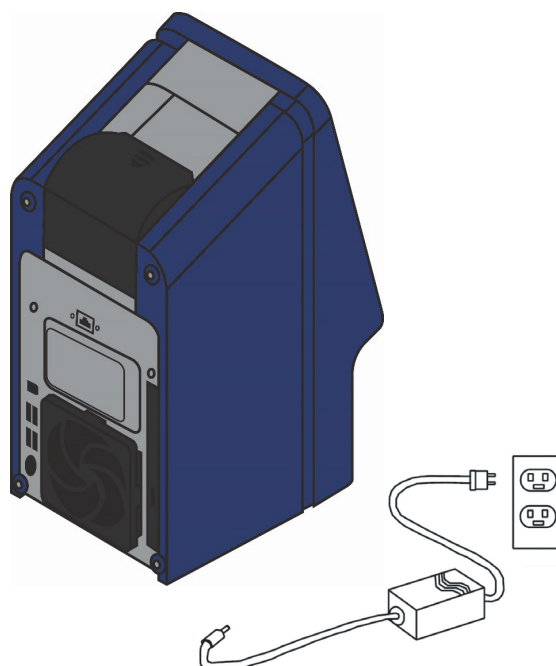

Note: *To prevent power surges or drain, **do not** plug the analyzer into the same circuit as a centrifuge or any other high-current device. If this is not possible, use an ancillary surge protector or battery backup for the analyzer.*

1.2.3 Step 3: Install Printer Paper Roll

1. Open the printer cover. If the printer contains a roll of printer paper, remove it from the printer.
2. Remove the wrapper from the new paper roll, then unroll several inches of paper.
3. Put the roll into the printer so that paper unrolls from the bottom of the roll and out towards the front of the analyzer, as shown at right.
Make sure several inches of paper extend out of the printer slot.
4. Press the cover closed till it locks into place.
5. Pull gently on the end of the paper until it is taut.



1.2.4 Step 4: Set System Parameters

Use the Settings icon  to set the analyzer's system parameters.

1. Set the date and time. See [“Changing Date and Time” on page 5-14](#) for details.

Note: *Be sure to set the date and time as accurately as possible. The analyzer uses this information to determine reagent dating when reading the bar-coded rotor before analysis. Inaccurate settings can cause errors.*

2. Set the measurement units to use in results. The analyzer is pre-set to report results in common units such as mg/dL. See [“Selecting Units” on page 5-16](#) for instructions on changing to SI units such as mmol/L.

The VetScan VS2 is now ready to run samples. See [“Test Procedure and Results” on page 4-1](#) for instructions.

1.2.5 If You Have Problems

If any of the following occurs, see “[Troubleshooting](#)” on page 8-1, or call Abaxis Technical Support at 1-800-822-2947, 24 hours a day, 7 days a week.

- The analyzer does not turn on. (First, verify that all connectors are firmly inserted and the electric outlet is working properly.)
- The rotor drawer does not open when you touch **Analyze** on the touchscreen.
- Error messages appear on the display.

When you call, the Technical Support Representative will ask for the following:

- A description of the problem.
- The analyzer serial number and software version number. See “[Viewing Analyzer Identification](#)” on page 5-13 for instructions on locating these numbers.

1.3 Guidelines for Obtaining and Using Samples

Follow these guidelines carefully in preparing the reagent rotor, and in obtaining and using samples.

1.3.1 Step 1: Prepare the Reagent Rotor

Note: Use only powder-free gloves, to keep powder off of analyzer optics.

- Use only reagent rotors that have not expired, as noted on the pouch and box. The VetScan VS2 Analyzer automatically rejects expired rotors.
- Do not remove the rotor from the refrigerator until you are ready to run the analysis.
- Use the rotor within 20 minutes of opening its pouch. **Do not** attempt to reseal the rotor in its pouch for later use.
- **Do not drop the rotor.** This could crack the rotor or shatter its reagent beads, which can cause errors and potential rotor cancellations.
- Handle the rotor only by its edges as shown at right. Fingerprints on the rotor can interfere with analyte measurements.



1.3.2 Step 2: Obtain a Sample

Sample Types

- **Whole blood samples:** Use only lithium heparin test tubes (green top).
- **Plasma samples:** Obtain these from whole blood samples (lithium heparin).
- **Serum:** Obtain from a sample placed in a red top test tube.

Note: **Do not use EDTA (lavender top test tube) for *any* samples to be tested on the VetScan VS2 Chemistry Analyzer.**

Guidelines for Obtaining Samples

- **Serum samples:** Use no-additive evacuated specimen collection tubes or serum separator tubes.
- **Whole blood or plasma samples:** Use only lithium heparin evacuated specimen collection tubes.
- Obtain a sample of approximately 100 μ L.
- When collecting the sample in lithium heparin collection tubes, fill the tube at least half-way to maintain the proper ratio of sample to anticoagulant.
- Run samples within 60 minutes. If this not possible, spin down and remove the plasma or serum.
- Place the plasma or serum into a clean red top tube, and run within five hours. If this is not possible, refrigerate the sample in a stoppered container at 2–8 °C (36–46 °F) for no longer than 48 hours. A plasma or serum sample can also be stored at -10 °C (14 °F) for up to five weeks in a freezer that does not have a self-defrost cycle.

Guidelines for Handling Samples

Use the following guidelines and procedures to ensure best results.

- Before dispensing, remove the needle to avoid hemolysis.
- Dispense the sample slowly into the sample tube.
- **For dehydrated patients:** Use plasma, or allow the sample to settle for 5 minutes and then draw from the top of the sample.

Test Tube Order

To prevent contamination, always fill test tubes in this order:

1. **Blue top:** Sodium citrate. Anticoagulant for coagulation only.
2. **Red top:** No anticoagulant.

Note: *Use the red top test tube only if necessary. If the red top tube is not needed, fill the green top tube first. But when needed, the red top tube **must** be filled before any other.*

3. **Green top:** Lithium heparin. Anticoagulant for chemistry only.
4. **Purple top:** EDTA. Anticoagulant for hematology only.

CAUTIONS: *Do not remove a sample from the rotor and try to reintroduce it to the rotor.*

Never place green top tubes on a test-tube rocker.

Store samples at room temperature, and use within 60 minutes.

EDTA contamination severely affects results, most notably Ca, Na, and K⁺.

Venipuncture Using Vacutainer or Syringe

Whole blood samples must be collected using lithium heparin as the anticoagulant. Excess heparin can interfere with certain chemistries, and can cause dilution. To prevent this, fill the vacutainer tube at least halfway with sample, then mix well by gently inverting two or three times.

The following venipuncture methods are available.

- **Preferred method: collecting sample directly into a lithium heparin vacutainer tube (green top).** If additional tubes will be filled, collect in this order to prevent adverse effects on results:
 1. blue
 2. red
 3. green
 4. lavender
- **Syringe with no anticoagulants.** Draw the sample, remove the needle, then immediately add the sample to lithium heparin (green top tube). Gently invert the tube two or three times to mix.

Note: *Do not shake the tube or hemolysis will result.*

1.3.3 Step 3: Add Sample to the Rotor

Sample Delivery Volume

Follow these guidelines to make sure you add the correct sample volume to the reagent rotor.

- When a sufficient quantity of sample is added, it will form a line between the arrows on the rotor surface.
- If an air bubble is introduced, add enough sample to fill the overflow area by 1/3 to 1/2, as shown at right.
- Make sure any excess sample does not travel beyond the overflow area.

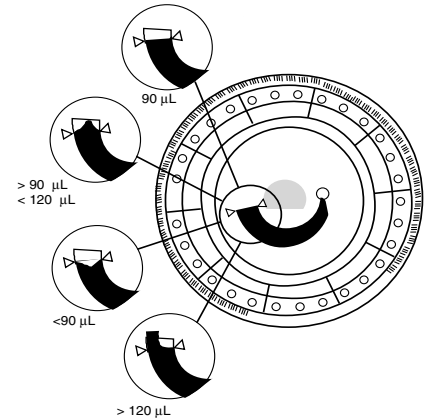

Using a Fixed 100 µL Volume Pipette

1. Firmly attach a new tip to the end of the pipette. **Do not** touch the tip, or a false elevation of amylase can result.
2. With your index finger or thumb, push the pipette plunger to the stop position, and hold it there for sample pickup.
3. Immerse the tip 2–3 mm below the surface of the sample, as shown at right.
4. *Slowly* release the plunger to draw the sample. Pause, then remove the pipette from the sample tube.
5. Make sure there are no air bubbles or gaps in the pipette tip.
6. Place the pipette tip into the rotor's sample port, so that the tip just touches the sample port, as shown at right.
7. *Gently and slowly* depress the pipette plunger to allow sample to slowly fill the sample chamber. See “[Sample Delivery Volume](#)” on [page 1-7](#) for the appropriate sample delivery volume.

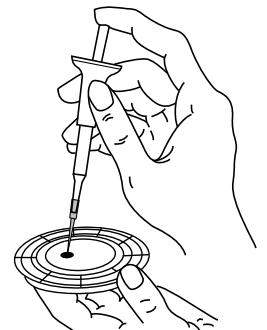
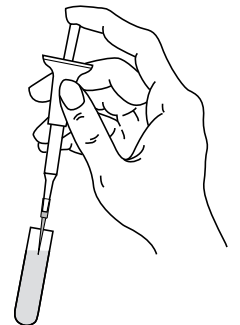

Note: *Keep the pipette plunger pressed down until you remove the tip from the sample port.*

Using a Disposable 100 μ L Capillary Pipette

1. Keep the capillary pipette horizontal until it is over the sample port.
2. Raise the pipette to vertical (so it is perpendicular to the rotor surface), and place its tip in the sample port, as shown at right.
3. Push the black plunger down slowly and smoothly until the white plug reaches the end of the capillary pipette. (There will be a slight resistance at first.) See “[Sample Delivery Volume](#)” on page 1-7 for the appropriate sample delivery volume.

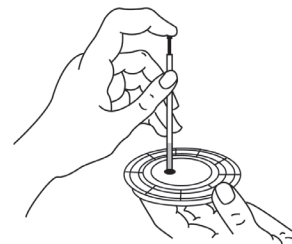

1.3.4 Step 4: Analyze the Sample

For the procedure, see “[Running Tests](#)” on page 4-4.

If problems occur, see “[Troubleshooting](#)” on page 8-1.

2.1 Intended Use

The VetScan VS2 Chemistry Analyzer provides quantitative *in vitro* determinations of clinical chemistry analytes in heparinized whole blood, heparinized plasma, or serum.

CAUTION: *If the VetScan VS2 Analyzer is used in any way other than described in this manual, the analyzer may not operate as intended, may produce inaccurate or no results, and may pose a safety hazard.*

Note: *Use only VetScan Reagent Rotors with the VetScan VS2 Analyzer.*

2.2 Introducing the VetScan VS2

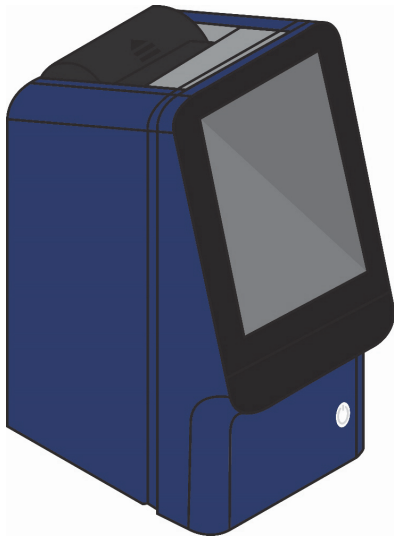

The VetScan VS2 Chemistry Analyzer is compact and easily transported, and consists of a portable blood analyzer and single-use disposable reagent rotors. The analyzer contains a variable-speed motor to spin the rotor, a photometer to measure analyte concentrations, two microprocessors to control testing and analytical functions, and a thermal line printer to print out results. The analyzer also provides a color touchscreen for communicating with the analyzer. A drawer in the front of the analyzer guides the reagent rotor into place for the analysis. The analyzer also features an express mode and an advanced mode.

The reagent rotor is a clear plastic disc, 8 cm in diameter and 2 cm thick. The rotor contains an aqueous diluent in the center and dry reagent beads in cuvettes around its periphery. All blood separation and sample diluent mixing steps are performed in the rotor.

Results are printed for inclusion in the patient's medical record. A network port and USB port are provided, and can be used to communicate with an external computer for data management.

To perform an analysis, the operator only needs to collect a blood specimen (heparinized whole blood, heparinized plasma, or serum), place the sample in the reagent rotor and the rotor into its drawer, input patient information, and print the results.





The entire analysis requires ~100 µL of sample and is capable of providing results in minutes.

2.3 Abaxis Technical Support

Abaxis Technical Support personnel can help with your questions about the VetScan VS2 Analyzer. Call Abaxis Technical Support, 24 hours a day, 7 days a week, at 1-800-822-2947.

2.4 Symbols Used in Labeling

The following symbols are found above the connectors or on the VetScan VS2 label, on the back of the analyzer.

Symbol	Explanation
	Direct Current
	Caution (refer to accompanying documents)
	Biohazard In accordance with good laboratory practice, all material from human sources should be considered potentially infectious, and handled with the same precautions used with patient specimens.
	USB Connection
	Network Port

2.5 Frequently Asked Questions

- [“General Questions” on page 2-3](#)
- [“Analyzer Setup Questions” on page 2-4](#)
- [“Samples” on page 2-5](#)
- [“Rotors” on page 2-5](#)
- [“Testing and Results” on page 2-6](#)

2.5.1 General Questions

- **Is the VS2 a “one test at a time” system?**

No. The VS2 offers a variety of assays in a number of preconfigured panels for the utmost flexibility, while requiring only seconds of hands-on time, and providing the lowest possible operating costs.

See [“Methods Performance” on page C-1](#) for information on assays and panels.

- **Do I need a separate instrument for electrolytes or blood gases?**

No. The VS2 offers Na⁺, K⁺, tCO₂, and Cl⁻ on certain panels, which can be run on the same unit, test procedure, and sample.

- **Can the analyzer detect a flawed or defective rotor?**

Yes. The VS2’s extensive Intelligent Quality Control (iQC) detects any flaw or potential anomaly in the rotor. Abaxis also provides a Performance Guarantee covering manufacture-defective rotors. (This does not include cancellations or assay suppressions due to improper rotor storage, operator error, or inadequate sample integrity.)

- **How many species can the VS2 store for reference ranges?**

In addition to cat, dog, and horse, the VS2 includes 99 pre-determined species labels for entering your own reference ranges (see [“Customizing Reference Ranges” on page 5-2](#)), and also provides 99 open labels for adding further species.

- **How many result records can the VS2 hold?**

The VS2 stores the results of the last 5000 rotors run. Thereafter, the VS2 replaces the oldest record with the most recent.

- **What maintenance does the VS2 require?**

The only required maintenance is cleaning the air filter on the back of the analyzer.

See [“Cleaning the Air Filter”](#) on page 10-2.

2.5.2 Analyzer Setup Questions

- **Does the VS2 require calibration?**

No. Unlike any other system, the VS2 reagents are factory-calibrated. Determined by Abaxis quality control methods within the factory, calibration factors provide mathematical adjustments interpreted by the analyzer from the rotor's barcode to correct for lot to lot reagent variations.

- **Does the VS2 need surge protection or an uninterruptable power supply?**

Abaxis recommends plugging the VS2 into a surge protector designed for use with a computer. Abaxis also recommends using an uninterruptable power supply (UPS) in areas prone to electrical surges or power outages.

- **Can I connect the VS2 to an external computer?**

Yes. Sample results and status reports can be transmitted to a computer (through a USB or network port). You can use popular terminal emulation software to collect the data from the VS2. The data is delivered in raw ASCII format, and can easily be converted to text for use in other applications.

For information about optional Ethernet connectivity capabilities, or ASTM or XML connections, contact Abaxis Technical Support, 24 hours a day, 7 days a week, at 1-800-822-2947.

The VS2 also interfaces with many commercial veterinary data management software packages. For information on compatible packages, check with your software vendor, or contact Abaxis Technical Support.

2.5.3 Samples

- **What types of samples can I run on the VS2?**

Whole blood, serum, or plasma.

- **Is precision pipetting required?**

No. Adding approximately 100–120 µl of sample is sufficient. (Make sure not to overfill the chamber, or internal spills can result.) The VS2's on-board microfluidics handle the rest.

- **Can I use sodium heparin?**

No. This anticoagulant can alter results. We recommend using lithium heparin with the VS2.

- **Can I use whole blood directly in a rotor?**

No. Syringes might be heparinized with sodium heparin anticoagulant, which is not recommended for use with the VS2. Instead, transfer the sample to a green top lithium heparin tube before loading into the rotor.

2.5.4 Rotors

- **If I inadvertently run an outdated rotor, do I risk inaccurate results?**

The analyzer checks the rotor, and cancels the run if the rotor is outdated. *This makes it essential to set your VS2 to the correct date and time.* See “[Changing Date and Time](#)” on page 5-14 for instructions.

- **What is the shelf life of rotors?**

Rotor shelf life depends on the type of rotor, but averages approximately 9 to 18 months from the date of manufacture. See the package label to determine the rotor expiration date.

To ensure optimal performance through the expiration date, the rotors *must be refrigerated* at 2–8° C (36–46° F), and used one at a time directly from the refrigerator.

Note: *Do not store rotors in the freezer. This freezes the diluent pack, which prevents it from running properly in the instrument.*

- **If a rotor was exposed to heat do I risk unreliable results as with other systems? Or if it's run too cold?**

Always store rotors in the appropriate conditions to help ensure accurate results. Rotors may tolerate brief exposure to heat or cold, but excessive exposure to extreme temperatures suppresses reporting of some results, since the VS2's extensive built-in iQC mechanisms protect against reporting results for potentially compromised analytes.

- **Do rotors require warm-up before use?**

No. In fact, you should use rotors directly from the refrigerator.

2.5.5 Testing and Results

- **Does hemolysis, lipemia, or icterus affect the results on the VetScan VS2?**

Endogenous substances such as hemolysis, lipemia, and icterus affect *all* blood chemistries, regardless of the type, size, or cost of the analysis instrument.

The VetScan VS2 is the *only* point-of-care analyzer that assesses and suppresses hemolysis, lipemia, and icterus by determining assay-by-assay the level at which these substances could affect the reliability of the results, and bringing this to the user's attention. This feature also provides useful information for monitoring sample handling practices, and whether patients fasted before arriving at the practice.

- **What do the tilde (~ ~ ~) symbols in the results mean?**

These symbols mean that the VS2's iQC algorithm is functioning correctly and results for that particular chemistry analysis were suppressed. If the VS2 cannot assure reliable results because of sample quality, endogenous substances, or unmeasurable analysis, the analyzer suppresses the results rather than simply report unreliable numbers.

- **What happens if I run a rotor under the wrong species?**

The analyzer is specifically calibrated for different species. If a rotor is run under the wrong species bank, the results will be unusable, and the rotor must be run again under the correct species.

■ **Can the VS2 results be transmitted to my lab management software?**

Most lab management software is compatible with Abaxis equipment. Check with your software company to be certain.

■ **Can I back up the results on my VS2?**

No, but you can print out reference ranges and results, or transfer them for storage in your lab management software.

■ **Can patients other than equine, large animal, or avian use the Equine, Large Animal, and Avian profiles?**

No. Profiles and reference ranges are designed for the specific species indicated on the package label. Running samples of other species can provide inaccurate results because some analytes are species-specific. See the rotor package insert for more information.

■ **My results do not match clinical observation. Does my VS2 need service?**

If your results are extremely low, and would not seem to support life (for example, $K^+ < 1.5$), this is likely the result of too little sample. This prevents the rotor from distributing the sample correctly, resulting in extremely low results for more than three chemistries. Rerun the sample for accurate results.

Set Up and Analyzer Description

3.1 Unpacking the Analyzer

1. Remove the VetScan VS2 Chemistry Analyzer from the shipping carton. Place the analyzer on a level surface relatively free of animal hair, dust, and other contaminants. Do not place in a sunny window or near another heat source. See the required environmental specifications on [page 3-5](#).
2. Check the components received with the VS2 against the list and figure below to make sure everything required to set up the analyzer is included.

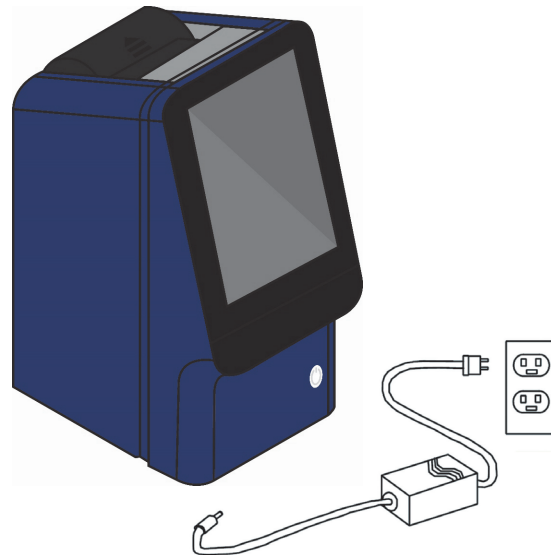

- VetScan VS2 Chemistry Analyzer
- Power adapter with cord
- Power cord
- USB cable (not shown)
- Abaxis Driver CD (not shown)
- VetScan VS2 operator's manual, quick reference guide, warranty card, and start-up packet (not shown)

3. Complete the warranty online at www.abaxis.com/warranty within 10 days of installation to start the warranty period. Customers are placed on the customer mailing list to receive information pertaining to the VS2 and ancillary products, such as software upgrades and new product announcements.

3.2 Setting Up the Analyzer

Refer to the required environmental specifications in “[Analyzer and Environmental Specifications](#)” on page 3-5.

1. Make sure that the VetScan VS2 is:
 - On a sturdy, level surface, free of vibration and sudden jolts.
 - In an ambient operating temperature of 15–32 °C (59–90 °F).
 - In an environment free of animal hair, dust, and other contaminants.
 - Not placed near a sunny window or another heat source.
 - At least six inches from the wall for access to the power connection and USB ports.

Note: *If the analyzer is subjected to an electrostatic discharge event, you may need to restart the unit.*

2. Plug the power jack into the analyzer, and plug the detachable power supply cord into the power adapter and into a grounded electrical outlet.

CAUTION: *To prevent power surges or drain, **do not** plug the analyzer into the same circuit as a centrifuge or any other high-current device. If this is not possible, use an ancillary surge protector or battery backup for the analyzer.*

WARNING: ***USE ONLY THE VS2 POWER SUPPLY. ANY OTHER POWER SUPPLY WILL DAMAGE THE INSTRUMENT AND VOID THE WARRANTY.***

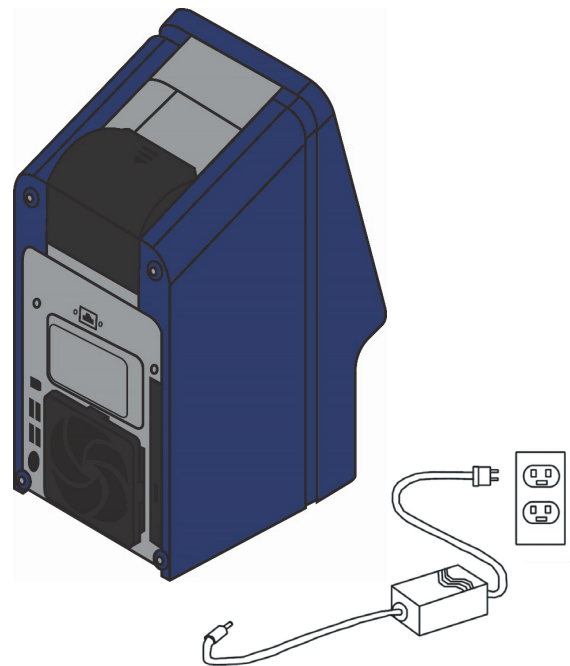

3. Install a paper roll in the analyzer's printer.
 - a. Open the printer cover. If the printer contains a roll of paper, remove it.
 - b. Remove the wrapper from the paper roll, then unroll several inches of printer paper.
 - c. Put the paper roll into the printer so that the paper unrolls from the bottom of the roll and out towards the front of the analyzer, as shown.
 - d. Make sure several inches of paper extend out of the printer slot, then press the cover closed till it locks into place.
 - e. Pull gently on the end of the paper to make sure it is taut.

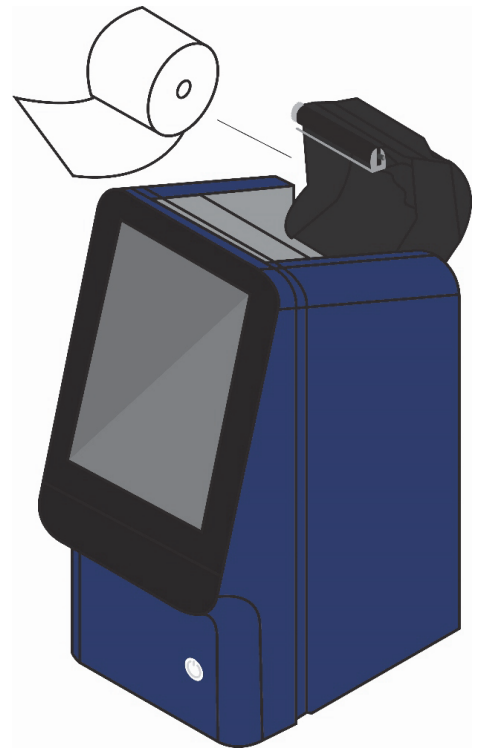

4. Press the Power button to turn the analyzer on.

The analyzer then begins its power-up cycle:



Note: *If no display message appears (blank display), remove the plug from the adapter, re-attach, and press in firmly. See “Quality Control Features” on page 7-1 for details about the analyzer self test. You may need to allow additional time for the heaters to warm the analyzer to operating temperature.*

The analyzer then warms up:

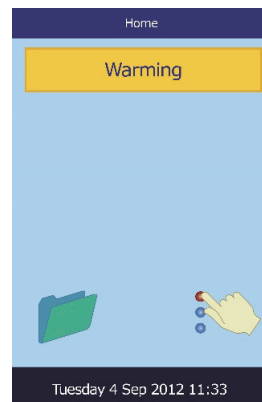

5. After passing the self test and reaching operating temperature, the analyzer is ready to run the first reagent rotor, and displays **Analyze**.
6. Make sure the analyzer date and time are correct. See [“Changing Date and Time”](#) on page 5-14 for directions.
7. To connect the VS2 Analyzer to an external computer or printer, see [“Connecting to an External Computer”](#) on page 11-1 for directions.

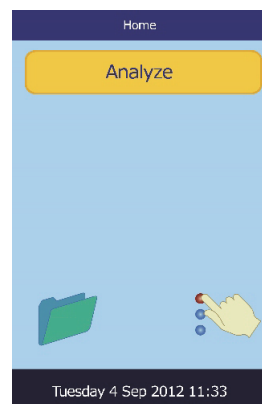

8. The following species are available: CAT, DOG, HORSE, and OTHER. Each species has a set of reference (or “normal”) ranges associated with it for each method. When the analyzer is shipped from the factory, the reference ranges for CAT, DOG, and HORSE animal types are pre-defined; these values can be changed using the Customizing Reference Range feature described in [“Customizing Reference Ranges”](#) on page 5-2.

Note: *To order reagent rotors, pipettes, tips, and printer paper, contact an authorized distributor, or contact Abaxis Customer Service at 1-800-822-2947 during regular business hours.*

3.3 Analyzer and Environmental Specifications

Analyzer dimensions:	<i>Height:</i> 32.5 cm (12.80 inches) <i>Width:</i> 14.9 cm (5.87 inches) <i>Depth:</i> 21.0 cm (8.27 inches)
Weight:	<i>Analyzer:</i> 5.3 kg (11.6 pounds) <i>Power Adapter:</i> 1.0 kg (2.3 pounds)
Mode of operation:	<i>Continuous</i>
Protection against ingress of fluids:	<i>Ordinary equipment (IPXO)</i>
Altitude:	<i>2000 m (6562 ft)</i>
Ambient operating temperature:	<i>15–32 °C (59–90 °F), indoor use</i>
Humidity:	<i>8–80% relative humidity noncondensing</i>
Reaction temperature:	<i>37 °C (98.6 °F)</i>
Thermal protection rating:	<i>70 °C (158 °F)</i>
Power requirements:	<i>100–240 volts AC, 50–60 Hz or 16 Volts DC, 5.0 A Main unit: 1.1 to 0.45 amps, 16 volts DC, 5.0 A</i>
Main supply voltage:	<i>Fluctuations not to exceed ± 10% of the nominal voltage</i>
Transient overvoltages:	<i>Installation Category II in accordance with UL 61010A-1 second edition Annex J</i>
Pollution:	<i>Degree 2 in accordance with IEC 664</i>

3.4 VetScan VS2 Chemistry Analyzer Overview

Note: Be sure to become familiar with the VS2 before running samples.

The VetScan VS2 Chemistry Analyzer consists of a portable analyzer and disposable single-use reagent rotors. Each reagent rotor contains all the reagents needed to perform a profile of tests on a single sample.

The VetScan VS2 uses centrifugal and capillary forces to process heparinized whole blood samples and distribute diluted plasma to the reaction chambers (cuvettes) in the reagent rotor. Serum and heparinized plasma samples are processed in a similar manner. The analyzer optically measures the chemical reactions and calculates analyte concentrations from these measurements and from encoded calibration data contained on the bar code ring.

Results are stored in memory, printed by the analyzer’s internal printer, and can be communicated to external computers for various types of data management.

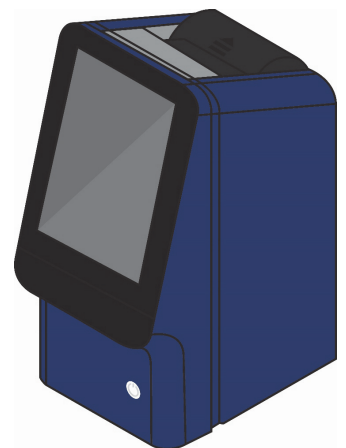

The analyzer communicates to the operator through the display screen. The display gives procedural instruction, indicates the status of the analyzer, and presents error messages.

The operator provides information to the analyzer through the touchscreen — for details, see “[Touchscreen](#)” on page 3-6.

The rotor drawer slides out from the front of the analyzer, transports the reagent rotor into the analyzer, and positions it for analysis.

Two power supply cords are provided: one connects to the power adapter and to the back of the analyzer, while the other connects the power adapter to power supply (a surge protector designed for use with a computer is recommended). The external adapter changes the electrical outlet voltage to the DC voltage required by the analyzer.

The analyzer includes a USB connector and a network port, which can be used for various communication links. See “[Connecting to an External Computer](#)” on page 11-1 for details.

The operator can easily carry the analyzer using the recessed handle incorporated into the top of the unit.

3.4.1 Touchscreen

The operator communicates with the analyzer through a touchscreen.

Turn the analyzer on or off by pressing and holding the Power button on the front of the instrument.

Note: Before powering off the analyzer, be sure to remove and dispose of any rotor in the instrument.



To open or close the drawer, touch **Analyze** or **Close** on the touchscreen. When open, the operator can insert or remove a reagent rotor (see “[Collecting Samples](#)” on page 4-2). Closing the drawer containing a reagent rotor begins the analysis.

- The operator uses on-screen keyboard to input patient information.



- The left and right arrow touchscreen keys move the display cursor forward or backward to change a number on the display.
- The right arrow key (\triangleright) functions as a dash (–), and the left arrow key (\triangleleft) functions as a backspace.
- Use the up (\triangle) and down (∇) arrow keys to scroll through a displayed list of items, or to increase or decrease a displayed value.
- Operating functions are accessed through various icons on the touchscreen, as well as specific keys that appear on the touchscreen according to the actions performed.
- Touch **Back** on the touchscreen to cancel a choice and return to the previous screen, or to move backward through a series of screens.

Results for previously analyzed samples can be accessed using the Recall function. See “[Recalling Results](#)” on page 6-1 for details on using this feature.

3.5 Reagent Rotors

The reagent rotors are specially designed to perform all the steps required to convert a few drops of blood into a panel of test results.

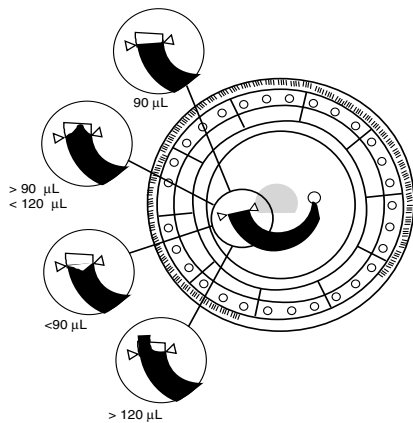

The rotor spins, separating the whole blood sample into plasma and cells. Precisely measured quantities of plasma and diluent are mixed together and delivered to the reaction cuvettes along the rotor perimeter. The diluted plasma dissolves the reagent beads, initiating the chemical reactions which are monitored photometrically. The bar code printed on the rotor bar code ring provides calibration data specific for the chemistries in the rotor, ensuring accurate results.

A sample is introduced into the reagent rotor via the **Sample Port**. A circle around the sample port is printed on the surface of each rotor to aid the operator in locating this port.

The **Sample Fill Line** is indicated by the two arrows on the rotor surface. The sample will form a line between the arrows when sufficient sample has been placed in the rotor sample chamber.

A **Diluent Container** is sealed with foil and can be seen in the center of the reagent rotor. The container is automatically opened after a rotor is inserted into the analyzer and the drawer is closed. The diluent is an aqueous solution which is used to dilute the plasma.

Cuvettes are located along the perimeter of the reagent rotor and contain analyte-specific dry reagent beads. System cuvettes perform internal rotor quality control. A dark cuvette and an open cuvette are employed in calibrating the analyzer photometer. Another cuvette ensures that an adequate amount of sample is in the rotor.

The **Bar Code Ring** is a white plastic piece that is attached to the top of the reagent rotor. A bar code is printed on the ring. The bar code ring is designed to keep fingerprints off the cuvette optical surfaces. It also aids in preventing contamination of the analyzer by capturing small drops of blood that may be on the rotor surface.

The **Bar Code** contains calibration coefficients, a rotor identification code, rotor lot number, and rotor expiration date. The analyzer automatically checks the expiration date of each rotor. Calibration data contained in the bar code provides the analyzer with data specific to the reagents in that particular rotor.

Test Procedure and Results

4.1 Introduction to Testing

Note: Use only VetScan Reagent Rotors with the VetScan VS2 Chemistry Analyzer.

The basic testing procedure is listed below. The remainder of this section describes the details of collecting samples and preparing the reagent rotor (“Collecting Samples” on page 4-2), sample processing (“Running Tests” on page 4-4), and interpreting results (“Using Test Results” on page 4-13).

1. Store rotors in a refrigerator (2–8 °C, 36–46 °F). Rotors can be used directly from the refrigerator without warming.
2. Collect the sample (lithium-heparinized whole blood, lithium-heparinized plasma or serum).
3. Remove the reagent rotor from its pouch.

CAUTION: Inspect the rotor for any damage before use.

4. Dispense ~100 μ L of sample into the rotor through the sample port, as shown at right.

A 100 μ L sample forms a line between the two arrows printed on the rotor. If there are air bubbles in the chamber, add more sample (not to exceed 120 μ L). Expel air or bubbles from the tip of the transfer device before adding more sample.

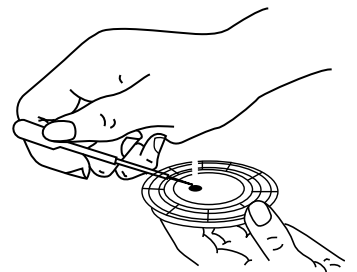

5. Touch **Analyze** on the touchscreen to open the analyzer's rotor drawer. Place the rotor in the drawer, then touch **Close** on the touchscreen.

There is no need to orient the rotor in a particular direction. Analysis begins automatically when the drawer closes.



6. Input patient information such as patient ID, operator ID, etc., as directed by the analyzer's display. The analyzer then processes the sample with no further input. Sample processing is complete when "Analysis Complete" appears on the display.
7. The results are stored in the analyzer and printed automatically. (Results can also be recalled and printed later as needed — see "[Recalling Results](#)" on page 6-1 for instructions).
8. Open the rotor drawer and remove the rotor. The rotor may be placed back into the foil pouch before disposal. Touch **Close** to close the drawer if another reagent rotor will not be run immediately.

THE VETSCAN VS2 CHEMISTRY ANALYZER IS NOW READY TO RUN THE SAMPLE.

4.2 Collecting Samples

Note: *Always follow these guidelines when collecting or testing samples:*

- *Analyze whole blood samples within 60 minutes of collection.*
- *Use the rotor within 20 minutes of opening the pouch.*
- *Run the rotor within 10 minutes of applying sample to the rotor.*

Approximately 100 μ L of sample is required. Use no-additive evacuated specimen collection tubes or serum separator tubes for serum samples. Use only lithium heparin evacuated specimen collection tubes for whole blood or plasma samples. **When collecting the sample in lithium heparin collection tubes, fill the tube at least halfway so the anticoagulant does not become too concentrated in the sample.**

Run whole blood samples within 60 minutes of collection. If this is not possible, separate the sample and transfer it into a clean test tube. Run the separated plasma or serum sample within 5 hours of centrifugation. If this is not possible, refrigerate the sample in a stoppered test tube at 2–8 °C (36–46 °F) for no longer than 48 hours. A heparinized plasma or serum sample can be stored at -10 °C (14 °F) for up to 5 weeks in a freezer that does not have a self-defrost cycle.

4.3 Adding a Sample to the Rotor

1. Remove the “practice” rotor from the start-up pack and practice loading a sample, using a preferred transfer device after reading the instructions in this section.

CAUTION: *The practice rotor is for sample loading practice only. **DO NOT RUN THIS ROTOR IN THE VS2 — IT WILL CANCEL THE ANALYSIS.***

Fixed 100 μ L Volume Pipette

- a. Firmly attach a new tip to the end of the pipette. **Do not** touch the tip (may cause false elevation of amylase).
- b. With the index finger or thumb, push the pipette button to the stop position and hold it down for sample pickup.
- c. Immerse the tip 2–3 mm below the surface of the sample as shown.
- d. Release the button **SLOWLY** to pick up the sample. Pause, then remove the pipette from the sample tube.

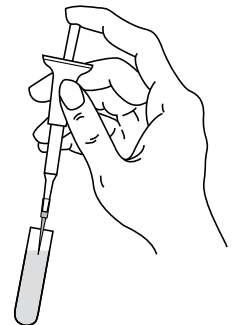

- e. Check that there are no air bubbles or air gaps in the pipette tip. Place pipette tip into the sample port of the rotor. The tip should touch the sample port as shown.

Refer to “[Sample Delivery Volume](#)” on page 4-4 for appropriate sample delivery volume.

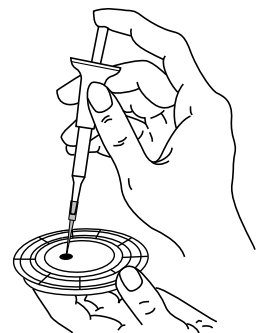

- f. Gently depress the button on the pipette to allow the sample to **SLOWLY** fill the sample chamber. **Keep the pipette button depressed until you remove it from the sample port.**

Sample Delivery Volume

Follow these guidelines to make sure you add the correct sample volume to the reagent rotor.

- When a sufficient quantity of sample is added, it will form a line between the arrows on the rotor surface.
- If an air bubble is introduced, add enough sample to fill the overflow area by 1/3 to 1/2, as shown at right.
- Make sure any excess sample does not travel beyond the overflow area.

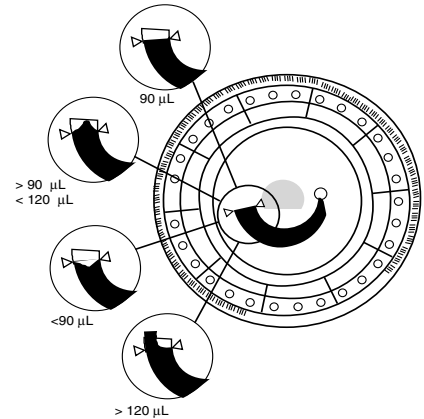

CAUTION: Do not try to remove the sample and reintroduce it to the rotor.

Note: After the sample is added to the rotor, make sure there is no excess blood on the top of the rotor. Gently wipe off the excess, being careful not to draw any sample from the sample port. Excess sample can spin off the rotor and into the rotor chamber, and can degrade performance.

4.4 Running Tests

This section includes detailed, step-by-step instructions for performing analyses using the VS2.

Note: The VS2 includes a number of optional data functions that can be used to enter more detailed information about samples.

In this manual, the screens for these functions are marked with this icon:



However, the screens for these functions will appear on the analyzer only if the functions are enabled. **If the screen shown in the manual does not appear on the analyzer screen, skip that step.**

See “[Setting Optional Advanced Functions](#)” on page 5-28 for details about these functions.

1. Turn on the analyzer power by pressing the Power button on the front of the analyzer.
Do this before removing reagent rotors from the refrigerator.

The analyzer starts up, then performs a self test.

See “Quality Control Features” on page 7-1 for information about the analyzer self test. Alternatively, the analyzer can be left on.



On startup, the analyzer’s heaters may need time to warm the analyzer’s rotor chamber to operating temperature. If so, the analyzer displays this while warming up:

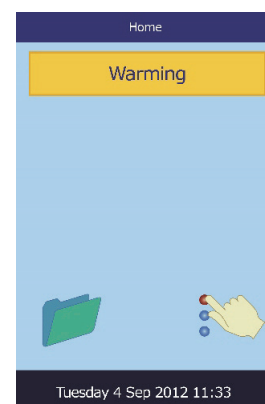

When the analyzer reaches operating temperature, it displays the main analysis screen.

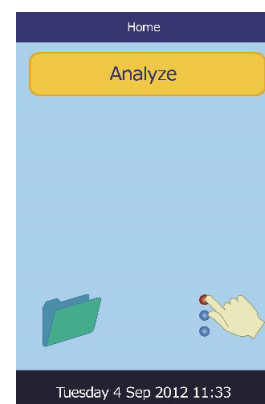

Note: *Rotors can be used directly from the refrigerator. (Prolonged time at room temperature can cause suppression of chemistries and rotor cancellations.) Do not expose rotors — in or out of pouches — to temperatures higher than 32 °C (90 °F).*

2. Inspect the unopened foil pouch for tears and punctures. Do not use a rotor from a damaged pouch.
3. Collect the sample. See “Collecting Samples” on page 4-2 for instructions.
4. Tear open the rotor pouch at the notch on the edge of the package.

Note: *A rotor must be used within 20 minutes of opening the pouch. Do not refrigerate a rotor after opening the pouch.*

- Remove the reagent rotor from the pouch by holding the edges of the rotor. This eliminates the possibility of fingerprints on the optical surfaces of the rotor.

CAUTION: *Inspect the rotor for any damage before use.*

- Use a transfer device to dispense ~100 μL of sample into the sample port.

Note: *Make sure whole blood samples are homogeneous before adding the sample to the reagent rotor. Gently invert the collection tube several times before filling the transfer device. Do not shake the collection tube; shaking can cause hemolysis.*

- Place the transfer device in the sample port (see “Collecting Samples” on page 4-2) and tilt the device until it is perpendicular to the rotor surface (device should touch the sample port).
- Fill the sample chamber by transferring the sample slowly and smoothly.

CAUTION: *Do not apply excess blood to the sample port. Excess blood may contaminate the analyzer.*

- A 100 μL sample will fill the sample chamber and form a line between the two triangles printed on the rotor, as shown in the figure at right. The reagent rotor is designed to handle up to 120 μL of sample which will partially fill the well just beyond the two triangles.

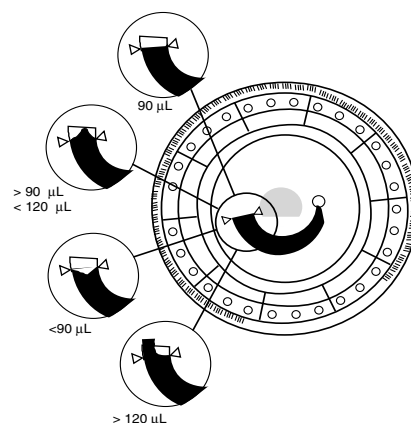

Note: *If an air bubble is introduced, add enough sample to fill the overflow area by 1/3 to 1/2. The figure at right shows sample volumes. Review this diagram before adding sample to the rotor.*

- Tilt the rotor approximately 45° so that the sample port is higher than the arrows. This will cause any sample remaining at the sample port to flow into the sample chamber.
- Do not spill blood on the bar code ring or reagent rotor. Carefully wipe up any spilled blood with a lint-free tissue. Ensure that the tissue does not pull any sample back out of the sample port.

8. Patient identification numbers may be written in the space indicated at right. Do not write anywhere else on the rotor or on the bar code ring.
9. Hold the reagent rotor by its edges and keep it in a flat position while carrying it to the analyzer.

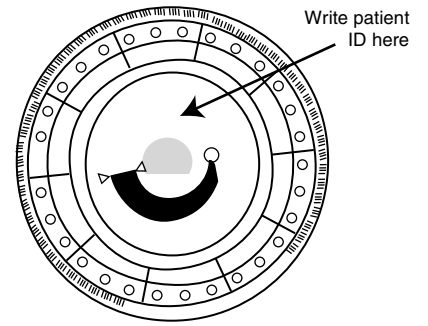

Note: *The test run must begin within 10 minutes of placing the sample in the reagent rotor.*

Sample volume should not exceed 120 μ L

10. Touch **Analyze** on the touchscreen to open the rotor drawer.

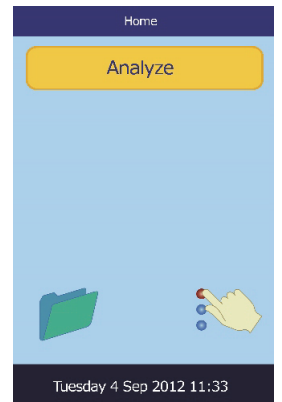

The following messages are then displayed:

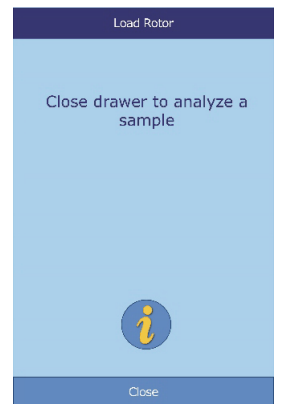
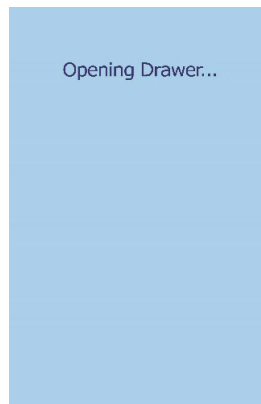

Note: In the Load Rotor screen, touch the information icon  to view additional help screens outlining the basic analysis procedure. (Touch **Next** and **Back** to move through the screens, and **Exit** to close them.)

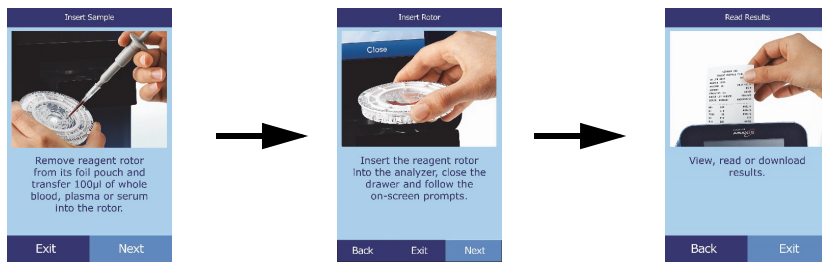

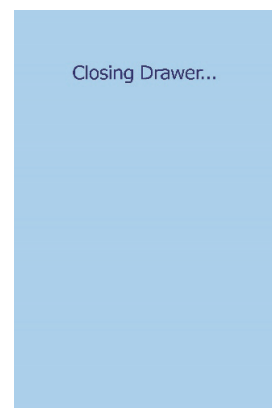

11. Place the rotor in the recessed area in the drawer.
12. Touch **Close** on the touchscreen. The analyzer then closes the drawer.



13.  Enter the operator ID using the touchscreen, then touch **Done**.

The operator ID is a string of up to 14 characters that is assigned by the facility.

The right arrow key () functions as a dash (–), and the left arrow key () functions as a backspace.

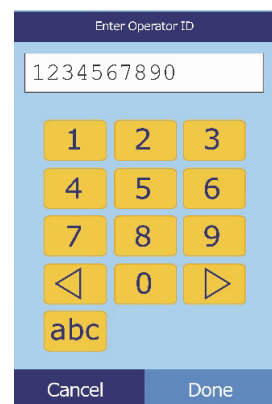

14. Select the species of the sample being analyzed from the choices shown in the display. (The exact choices depend on how the analyzer is configured — the figure shows the default selections.)

Select Type

Amazon

Cat

Control 1

Coyote

Dog

△

▽

Back Cancel

Note: *The correct Type is necessary for results to be interpreted correctly.*

15.  Select the patient's gender.

Select Gender

Unknown

Male

Female

Neutered

Spayed

Back Cancel

16.  Enter the patient's age using the up (△) and down (▽) arrow keys (be sure to adjust the units if needed), then touch **Done**.

Enter Age

0 2 Yrs.

△ △ △

▽ ▽ ▽

Back Done

17. Enter an ID number for the patient (up to 14 characters), then touch **Done**.

The right arrow key (▷) functions as a dash (–), and the left arrow key (◁) functions as a backspace.

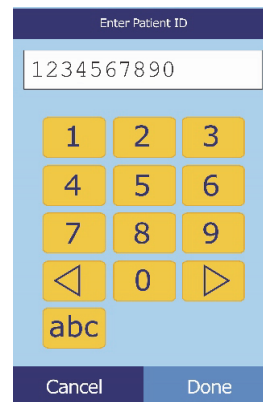

18.  Enter an alternate ID (up to 14 characters), then touch **Done**.

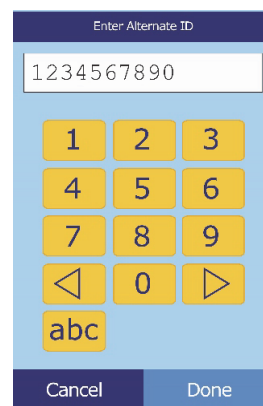

CAUTION: *Do not lean on the analyzer, nor place potentially hazardous material on the analyzer during analysis.*

19. The analyzer checks the rotor type, and begins processing the sample with no further input.

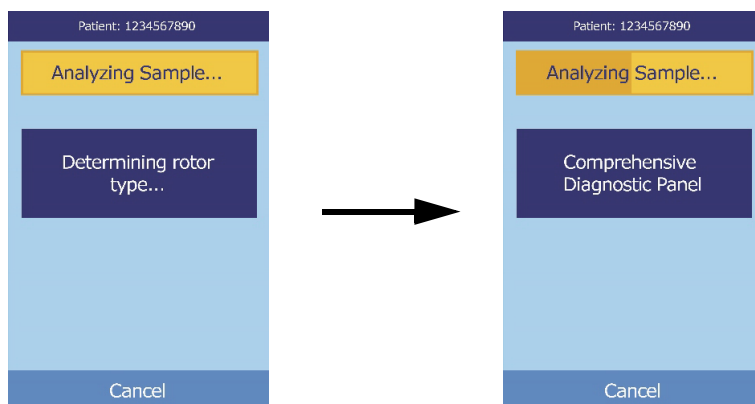

20. When the sample is finished processing, the analyzer stores the results and shows that analysis is complete.

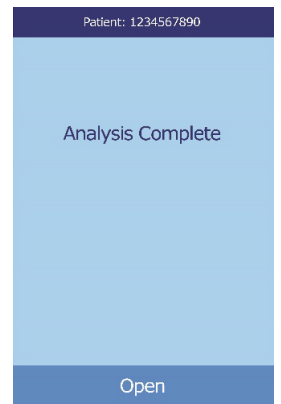

21. By default, the analyzer automatically prints the results of the analysis.

If the results do not print automatically, they can be recalled from memory and printed — see “Searching Results,” on page 6-3.

Note: *Be sure to review the results printout for any suppressed results, which are marked with these symbols: ~~~*

22. Touch **Open** to open the rotor drawer.

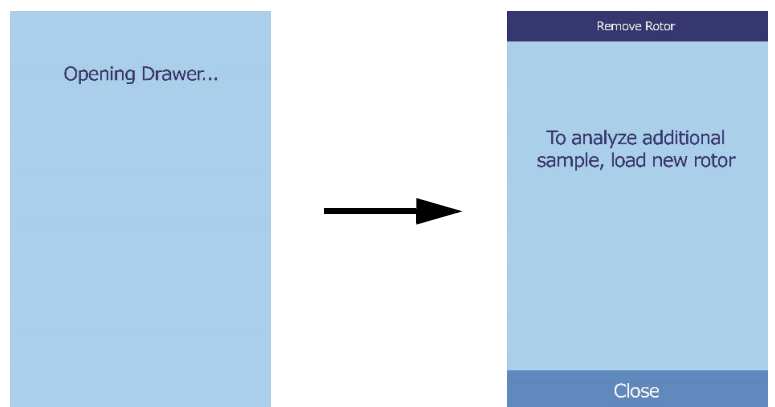

23. Remove the rotor from the drawer.

CAUTION: *Dispose of the rotor according to the lab’s standard procedures for animal samples.*

24. To analyze another sample, insert a new rotor and repeat the above procedure.

- When finished, touch **Close** to close the drawer and return the analyzer to standby mode.

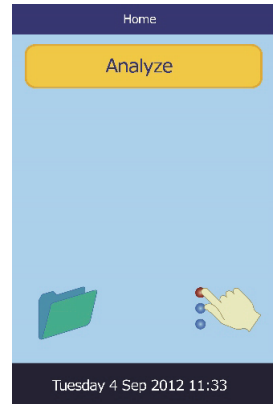

4.5 Canceling an Analysis

- To cancel an analysis in process, touch **Cancel** on the touchscreen.

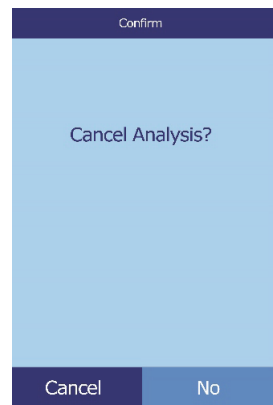

- Touch **Cancel** to confirm. The analysis is then canceled, and the rotor drawer opens.

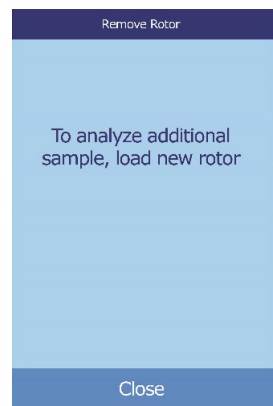
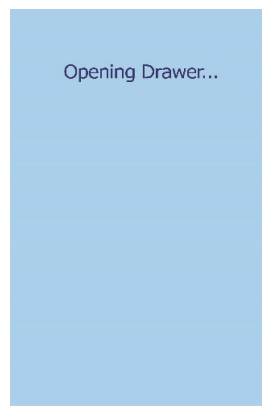

- Remove the rotor from the drawer. The analyzer is now ready to perform another analysis. Touch **Close** to close the drawer.

4.6 Using Test Results

The results calculated by the analyzer are stored in memory and printed automatically, and can be recalled and printed later as needed. If the analyzer is connected to an external computer, the results are automatically transmitted as soon as they are calculated. See “Principles of Operation” on page 9-2 for the basic procedure and equations used to calculate analyte concentrations.

The figure at the right shows a typical results printout. The heading includes information such as the test date and time, sample type, patient identification number, reagent rotor type, rotor lot number, operator identification number, and analyzer serial number. The test results section is printed in multiple columns, including chemistry name, analyte concentration, and reference range in specified units, as shown at right.

Each rotor contains reagents to detect exposure to extreme conditions such as temperature and humidity. The message **QC OK** is printed on the results when results from these reagents are within the expected ranges. Otherwise, no results are printed, and the analyzer opens the rotor drawer.

- Results outside the reference range are indicated in by an asterisk (*) next to the analyte concentration.
- Results outside the dynamic range and system range are indicated by a “less than” symbol (<) next to the lowest value of the dynamic or system range, or a “greater than” symbol (>) next to the highest value of the dynamic or system range. (For example, concentrations outside Glucose dynamic range are printed as < 10 or > 700 mg/dl, respectively, and concentrations outside Glucose system range are printed as 0 or > 1200 mg/dl, respectively.)

VetScan VS2			
Comprehensive Diagnostic			
07 Nov 2012			10:30 AM
Sample Type:			Dog
Patient ID:			78
Rotor Lot Number:		2131AB4	
Serial Number:		HSL2VJ0028	
.....			
ALB	4.9 *	2.5-4.4	g/dL
ALP	408 *	20-150	U/L
ALT	183 *	10-118	U/L
AMY	302	200-1200	U/L
TBIL	4.4 *	0.1-0.6	mg/dL
BUN	52 *	7-25	mg/dL
CA	12.5 *	8.6-11.8	mg/dL
PHOS	5.3 *	2.9-6.6	mg/dL
CRE	5.3 *	0.3-1.4	mg/dL
GLU	283 *	60-110	mg/dL
NA+	153	138-160	mmol/L
K+	7.1 *	3.7-5.8	mmol/L
TP	7.9	5.4-8.2	g/dL
GLOB	3.0	2.3-5.2	g/dL
.....			
QC	OK		
HEM 0	LIP 1+	ICT 1+	

- The symbols ~~~ are printed in place of numbers when a result cannot be determined — that is, when the result is suppressed. A result can be suppressed due to improper mixing of a reagent bead with diluted sample, a nonlinear reaction, an endpoint of a particular reaction not reached, or a concentration outside the analyzer’s capabilities. When a chemistry is suppressed (~~~), the analyzer prints an error report by default.
- **HEM**, **LIP**, or **ICT** is printed in place of the analyte concentration if hemolysis, lipemia, or icterus has adversely affected the results. **LIP** is also printed if both lipemia and icterus have been affected. **HEM** is also printed if hemolysis and icterus, hemolysis and lipemia, or hemolysis, lipemia, and icterus have affected a particular analyte. Examine the sample indices to determine if more than one interferent is affecting a particular result.
- The sample indices are included at the bottom of the results. These indicate the degree of hemolysis, icterus, and lipemia found in the sample, measured on a scale of 0 (clear), 1+ (slight), 2+ (moderate), and 3+ (gross).

If the sample is identified as hemolytic, collect a new sample and run another reagent rotor. If the new sample is also hemolytic, refer to [“Troubleshooting” on page 8-1](#). High lipemia may be due to diet. Ensure the patient has fasted for at least 12 hours before collecting another sample. For suggestions on testing grossly lipemic or icteric samples, see [“Troubleshooting” on page 8-1](#).

4.7 Test Procedure Summary

4.7.1 VetScan VS2 Chemistry Analyzer

- Check that the electrical outlet utilized for the analyzer is grounded.
- Check that the ambient temperature where the analyzer is located is 15–32 °C (59–90 °F).
- Do not disconnect the power to the analyzer while running a sample.
- Keep the analyzer drawer closed when not in use.
- Do not attempt to repair the analyzer; this may void the warranty. Refer to [“Troubleshooting” on page 8-1](#) for troubleshooting and [“Maintenance and Service” on page 10-1](#) for regular maintenance.

4.7.2 Reagent Rotors

- Do not use an expired rotor. The reagent rotor expiration date is printed on the foil pouch and is encoded in the bar code.
- Store all reagent rotors at 2–8 °C (36–46 °F) as described on their respective pouch labels. Rotors may be used directly from the refrigerator.
- Keep reagent rotors clean. Handle rotors only along the edges to eliminate the possibility of fingerprints on the cuvette optical surfaces. Use a lint-free tissue to clean off large quantities of blood.
- After introducing the sample, hold the reagent rotor flat to avoid spillage.
- Never use a reagent rotor that has been dropped.
- Use the reagent rotor within **20 minutes** of opening the foil pouch.
- Run the reagent rotor within **10 minutes** of applying the sample.

4.7.3 Samples

- Analyze whole blood samples within 60 minutes of collection.
- Fill the lithium heparin specimen collection tube at least halfway to ensure the sample does not have a high concentration of anticoagulant.
- To prevent hemolysis, do not refrigerate or shake whole blood samples.
- When adding blood to evacuated collection tubes, remove the needle from the syringe and the stopper from the tube, and gently place the sample into the tube. (If sample is injected through the stopper, hemolysis may occur.)

4.7.4 Handling Samples

Use the following guidelines and procedures to ensure best results.

Syringe Guide

- Use the following sizes according to the size of the patient:
 - ❑ Small breed: up to 10 kg — use a 25-gauge syringe.
 - ❑ Medium breed: 10–30 kg — use a 22-gauge syringe.
 - ❑ Larger breed: 30–60 kg — use a 20-gauge syringe.
 - ❑ Giant breed: over 60 kg — use an 18-gauge syringe.
- Before dispensing, remove the needle to avoid hemolysis.
- Dispense the sample slowly into the sample tube.
- **For dehydrated patients:** Use plasma, or allow the sample to settle for 5 minutes and then draw from the top of the sample.

Test Tube Order

To prevent contamination, always fill test tubes in this order:

1. **Blue top:** Sodium citrate. Anticoagulant for coagulation only.
2. **Red top:** No anticoagulant.

Note: *Use the red top test tube only if necessary. If the red top tube is not needed, fill the green top tube first. But when needed, the red top tube **must** be filled before any other.*

3. **Green top:** Lithium heparin. Anticoagulant for chemistry only.
4. **Purple top:** EDTA. Anticoagulant for hematology only.

CAUTIONS: *Do not remove a sample from the rotor and try to reintroduce it to the rotor.*

Never place green top tubes on a test-tube rocker.

Store samples at room temperature, and use within 60 minutes.

EDTA contamination severely affects results, most notably Ca, Na, and K⁺.

Configuring the Analyzer

This section describes how to configure the VetScan VS2 Chemistry Analyzer to achieve excellent performance.

- Make general analyzer settings as shown in “Using the Settings Screens” on page 5-2.
- Set species reference ranges for the specific patient population, and print, transmit, or archive these ranges.
 - “Customizing Reference Ranges” on page 5-2
 - “Printing and Archiving Reference Ranges” on page 5-10
 - “Transmitting Reference Ranges” on page 5-12
- Change general analyzer settings.
 - “Viewing Analyzer Identification” on page 5-13
 - “Changing Date and Time” on page 5-14
 - “Selecting the Language” on page 5-15
 - “Selecting Units” on page 5-16
 - “Setting Sound Volumes” on page 5-21
 - “Adjusting the Display” on page 5-22
 - “Configuring Printers” on page 5-24
 - “Setting Communication Protocol” on page 5-27
 - “Setting Optional Advanced Functions” on page 5-28

5.1 Using the Settings Screens

The following shows the general path through the menus for performing the procedures in this section. These procedures are available whenever the analyzer displays the Home screen.

1. In the Home screen, touch the Settings icon.

The Analyzer Settings screen then opens. From here, adjust the date and time, language, sound, display, and printer, or view basic information about the analyzer.

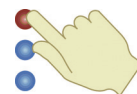

2. Touch the More Settings icon.

This opens the second Analyzer Settings screen. Use this screen as a starting point to make additional settings, work with reference ranges, or update the analyzer's software.

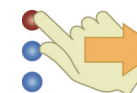

3. Touch **Home** to return to the analyzer's Home screen.

5.2 Customizing Reference Ranges

The reference ranges stored in the analyzer may be changed so that they are specific for a patient population. This can be done whenever the Home screen is displayed.

Note: *Change reference ranges in either Common units or SI units, not both. The analyzer automatically converts units.*

1. In the Home screen, touch the Settings icon.

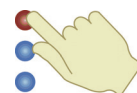

2. Touch the More Settings icon.

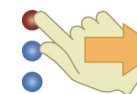

3. Touch the Reference Range Settings icon.

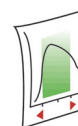

4. Select the reference range to modify.

- To modify the last reference range that was changed, touch **Last Modified**, then skip to step 4 on [page 5-4](#).
- To modify any reference range, touch **All**, then continue to step 5.

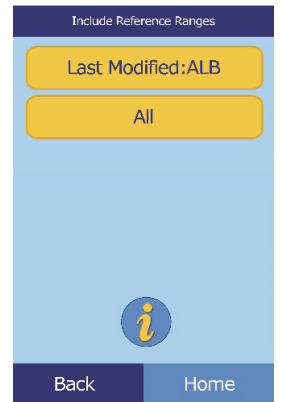

5. The Modify Reference Ranges screen then opens. From here, the following procedures are available:

- Modify the reference range for a specific analyte: see below.
- Modify a set of ranges associated with a particular species: see [page 5-4](#).
- Add a reference range for a new species: see [page 5-5](#).
- Delete a species: see [page 5-9](#).

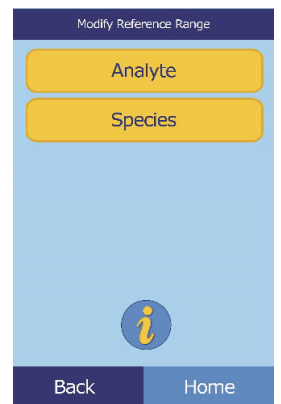

5.2.1 Modifying Reference Ranges of a Single Analyte

Change the reference ranges for a specific analyte as follows.

1. In the Modify Reference Ranges screen, touch **Analyte**.
2. Select the analyte from the list. Use the up (\triangle) and down (∇) arrow keys to scroll through the list.

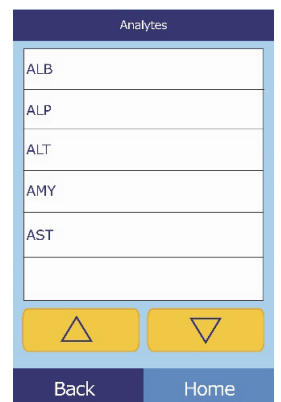

3. Select the reference range from the list. If needed, use the up (\triangle) and down (∇) arrow keys to view the entire list.



4. Use the controls to set the upper and lower limits for the range.
 - Use the up (\triangle) and down (∇) arrow keys to adjust the values.
 - Touch **Clear** to set both limits to zero.
 - Touch **Default** to use the factory default values for the range.
5. Touch **Save** to store the changes.

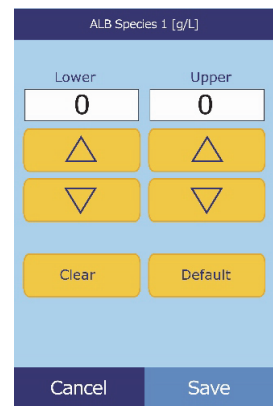

5.2.2 Modifying the Reference Ranges for a Species

Use this procedure to modify the reference ranges for a particular species, or the analyzer's default set.

1. In the Modify Reference Ranges screen, touch **Species**.
2. Choose a species from the list. Use the up (\triangle) and down (∇) arrow keys as needed to scroll through the list.



3. The analyzer displays the ranges for the species.

Select the analyte to adjust. If needed, use the up (Δ) and down (∇) arrow keys to scroll through the list.

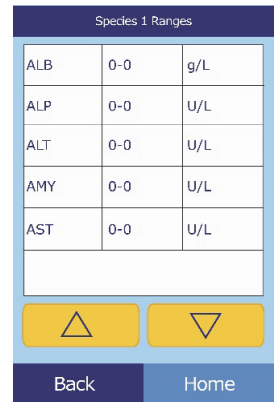

Species 1 Ranges		
ALB	0-0	g/L
ALP	0-0	U/L
ALT	0-0	U/L
AMY	0-0	U/L
AST	0-0	U/L

Navigation buttons: Δ (up), ∇ (down), Back, Home

4. Use the controls to set the upper and lower limits for the range.
 - Use the up (Δ) and down (∇) arrow keys to adjust the values.
 - Touch **Clear** to set both limits to zero.
 - Touch **Default** to use the factory default values for the range.
5. Touch **Save** to store the changes.

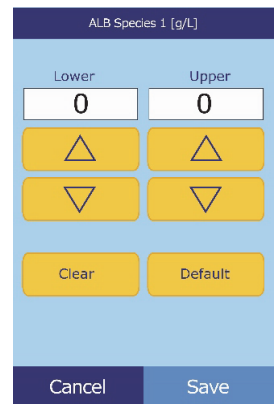

ALB Species 1 [g/L]

Lower	Upper
0	0

Navigation buttons: Δ (up), ∇ (down), Clear, Default, Cancel, Save

5.2.3 Adding a Species

Use this procedure to add reference ranges for a particular species (including pre-defined species).

1. In the Modify Reference Ranges screen, touch **Species**.
2. Touch **Add Species**.

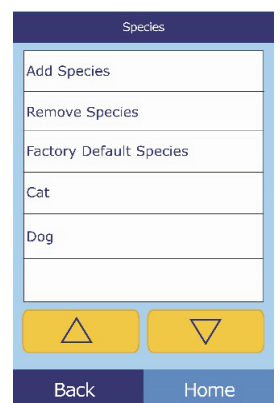

Species

- Add Species
- Remove Species
- Factory Default Species
- Cat
- Dog
-

Navigation buttons: Δ (up), ∇ (down), Back, Home

3. Touch **Species 1** to create a reference range for a new, unnamed species, **Control 1** to create a range for a new control level, or **Select** to create a reference range for a predefined species.

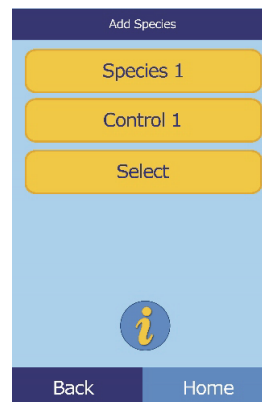

- To create a reference range for a new, unnamed species:

- a. Touch **Species 1**.
- b. Set minimum and maximum values for each of the analytes to be included in the range:
 - i. Select the analyte to adjust. If needed, use the up (Δ) and down (∇) arrow keys to scroll through the list.



- ii. Use the controls to set upper and lower limits for the analyte.

- Use the up (Δ) and down (∇) arrow keys to adjust the values.
- Touch **Clear** to set both limits to zero.
- Touch **Default** to use the factory default values for the range.

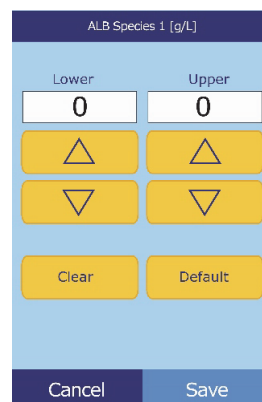

Note: *Entering zero for both values suppresses printing ranges for this analyte in results (blanks appear instead), and also suppresses checking the recovered value against the range limits.*

- c. Touch **Save** to store the changes.

- To create a new control:
 - a. Touch **Control 1**.
 - b. Set minimum and maximum values for each of the analytes to be included in the range:
 - i. Select the analyte to adjust from the list. If needed, use the up (Δ) and down (∇) arrow keys to view the entire list.

Control 1 Ranges		
ALB	0-0	g/L
ALP	0-0	U/L
ALT	0-0	U/L
AMY	0-0	U/L
AST	0-0	U/L

- ii. Use the controls to set upper and lower limits for the analyte.
 - Use the up (Δ) and down (∇) arrow keys to adjust the values.
 - Touch **Clear** to set both limits to zero.
 - Touch **Default** to use the factory default values for the range.

ALB Control 1 [g/L]

Lower: 0 Upper: 0

Buttons: Δ , ∇ , Clear, Default

Note: *Entering zero for both values suppresses printing ranges for this analyte in results (blanks appear instead), and also suppresses checking the recovered value against the range limits.*

- c. Touch **Save** to store the changes.

- To create a reference range for a particular pre-defined species label:
 - a. Touch **Select**.
 - b. Select the animal type from those listed. Use the up (Δ) and down (∇) arrow keys to scroll through the list.

Species Available

- Canines
- Felines
- Equines
- Bovines
- Avians

Buttons: Δ , ∇ , Back, Home

- c. Select the species. Use the up (\triangle) and down (∇) arrow keys to scroll through the list.

- d. Set minimum and maximum values for each of the analytes to be included in the range.

- i. Select the analyte to adjust. Use the up (\triangle) and down (∇) arrow keys to scroll through the list.

ALB	0-0	g/L
ALP	0-0	U/L
ALT	0-0	U/L
AMY	0-0	U/L
AST	0-0	U/L

- ii. Use the controls to set upper and lower limits for the analyte.

- Use the up (\triangle) and down (∇) arrow keys to adjust the values.
- Touch **Clear** to set both limits to zero.
- Touch **Default** to use the factory default values for the range.

Note: *Entering zero for both values suppresses printing ranges for this analyte in results (blanks appear instead), and also suppresses checking the recovered value against the range limits.*

- e. Touch **Save** to store the changes.

5.2.4 Removing a Species

Use this procedure to remove the reference ranges for a particular species.

1. In the Modify Reference Ranges screen, touch **Species**.
2. Touch **Remove Species**.

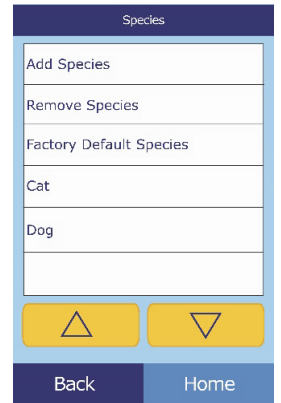

3. Select the species to remove. Use the up (\triangle) and down (∇) arrow keys to scroll through the list.



4. A warning screen then appears. Touch **Continue** to permanently remove the species.

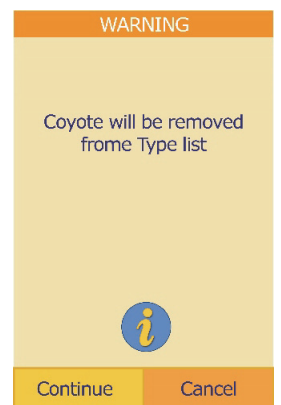

5.3 Printing and Archiving Reference Ranges

Reference ranges can be printed, or stored in the analyzer as archive files for later use or review.

1. In the Home screen, touch the Settings icon.

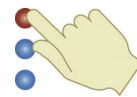

2. Touch the More Settings icon.

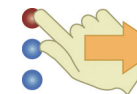

3. Touch the Archive Reference Ranges icon.



4. Touch **Send**.

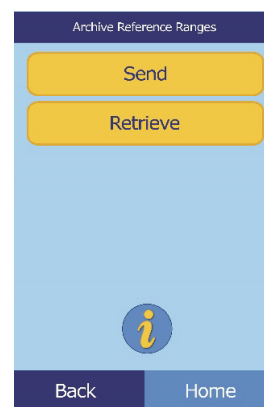

- To archive the reference ranges into the analyzer's internal memory, touch **Internal Archive**.

The reference range is then stored in the analyzer under the current date and time.

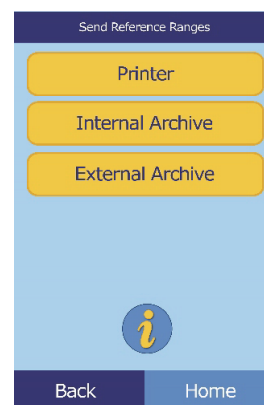

- To archive the ranges onto a PC connected to the analyzer:
 - a. Touch **External Archive**.
 - b. Select the species reference range to store.
The reference range is then stored on the PC under the current date and time.

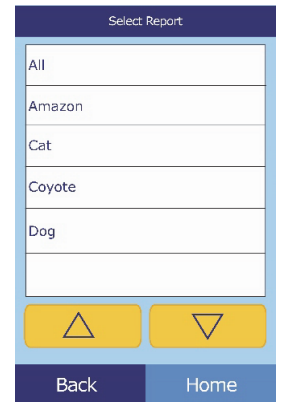

- To print a range:
 - a. Touch **Printer**.
 - b. Select the species reference range to print.

5.4 Retrieving Reference Ranges

Reference ranges can be retrieved from archives as follows.

Note: *Retrieving an archived reference range overwrites all reference range values currently in the analyzer. Consider archiving the current reference ranges before retrieving another set.*

1. Touch **Retrieve**.
2. Select the archive to retrieve. Use the up (\triangle) and down (∇) arrow keys to scroll through the list.



3. A warning screen then appears. Touch **Continue** to retrieve the archived reference range.

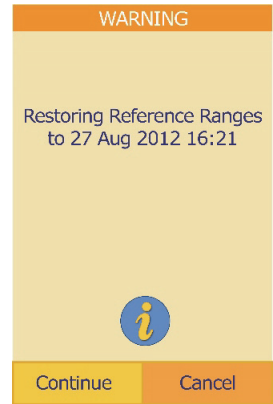

5.5 Transmitting Reference Ranges

Reference ranges can be transmitted to a connected PC and stored for later use or review.

1. In the Home screen, touch the Settings icon.

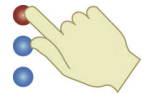

2. Touch the More Settings icon.

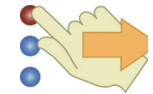

3. Touch the Archive Reference Ranges icon.



4. Touch **Send**.

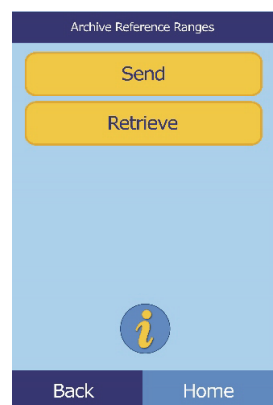

5. Touch **External Archive**.

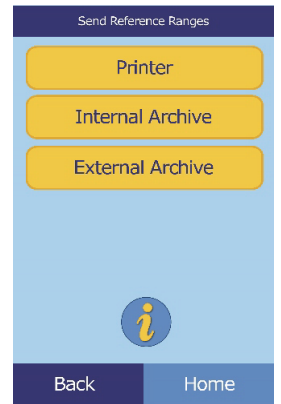

6. Select the species reference range to store.

The reference range is then stored on the PC under the current date and time.

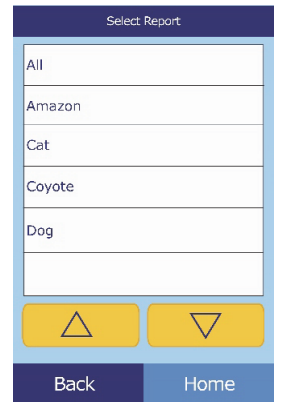

5.6 Viewing Analyzer Identification

Use this function to verify information about the analyzer, such as serial number and the version of the installed software.

1. In the Home screen, touch the Settings icon.



2. Touch the Analyzer Information icon.



3. The display then shows the analyzer information.

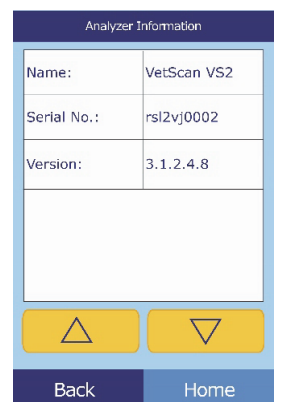

5.7 Changing Date and Time

The date and time is factory preset to Pacific Time. Reset the date and time as needed when setting up the analyzer, and periodically thereafter.

1. In the Home screen, touch the Settings icon.

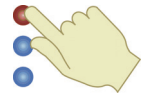

2. Touch the Date and Time icon.



3. Use the controls to set the time:

- Use the up (\triangle) and down (∇) arrow keys to adjust the hour and minutes.
- Touch **12/24 Hour** to switch between 12- and 24-hour time formats.
- Touch **Zero Sec.** to set the seconds to zero.

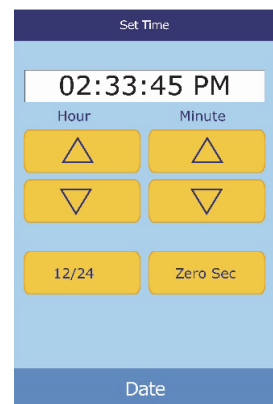

4. Touch **Date** when the time is set.

Note: *If the time entered is invalid, an error message appears — touch **Continue**, set the correct time, then touch **Done**.*

5. Use the up (\triangle) and down (∇) arrow keys to adjust the day, month, and year.

6. Touch **Done**.

Note: *If the date entered is invalid, an error message appears — touch **Continue**, set the correct date, then touch **Done**.*



5.8 Selecting the Language

The analyzer provides several languages for menus and printing. Select the language to use (English is the default) as follows.

1. In the Home screen, touch the Settings icon.

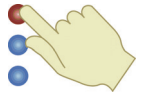

2. Touch the Languages icon.



3. Select the language from the list. If needed, use the up (Δ) and down (∇) arrow keys to view the entire list.



4. Select the keyboard type from the list. If needed, use the up (Δ) and down (∇) arrow keys to view the entire list.



5.9 Selecting Units

You can select either Common Units, such as mg/dL, or SI Units (Systeme International), such as mmol/L, to report results.

1. In the Home screen, touch the Settings icon.

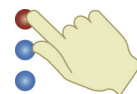

2. Touch the More Settings icon.

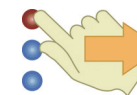

3. Touch the Units Settings icon.

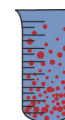

4. Set the units used for all analytes, a particular analyte, or a class of analytes (electrolytes, enzymes, minerals, or proteins) as follows.

- To set units for all analytes:

- a. Touch **All Analytes**.

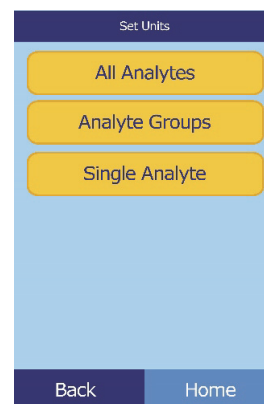

- b. Select the units to use for all analytes:
Non SI or **SI**.

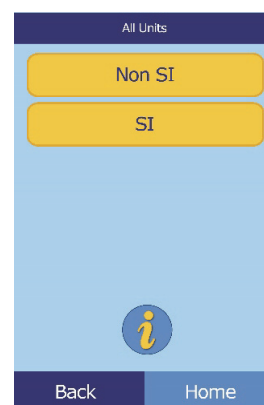

■ To set the units for a particular analyte:

a. Touch **Single Analyte**.

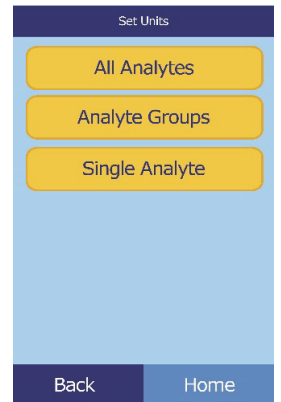

b. Select the analyte from the list. If needed, use the up (\triangle) and down (∇) arrow keys to view the entire list.

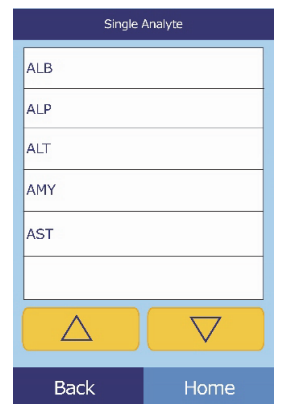

c. Select the units to use for the analyte: **g/dL**, **g/L**, **mg/dL**, **mg/L**, or **umol/L**.

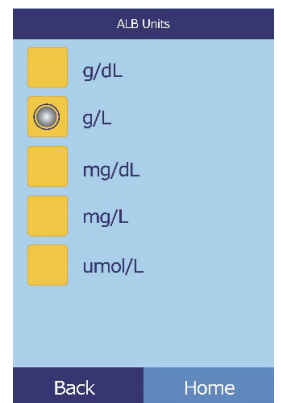

- To set units for all electrolytes:

- a. Touch **Analyte Groups**.

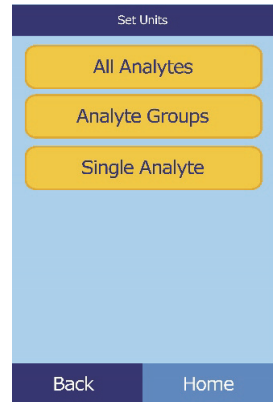

- b. Touch **Electrolytes**.

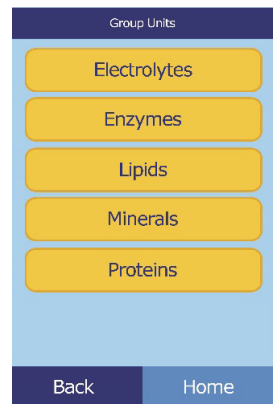

- c. Select the units to use for all electrolytes:
mmol/L or **mEq/L**.

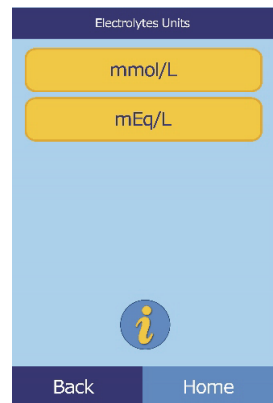

- To set units for all enzymes:

- a. Touch **Enzymes**.

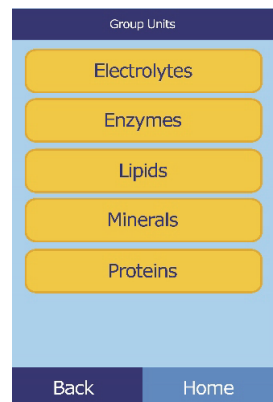

- b. Select the units to use for all enzymes:
U/L or **ukat/L**.

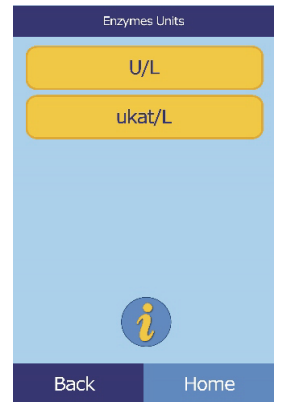

- To set units for all lipids:
- a. Touch **Lipids**.

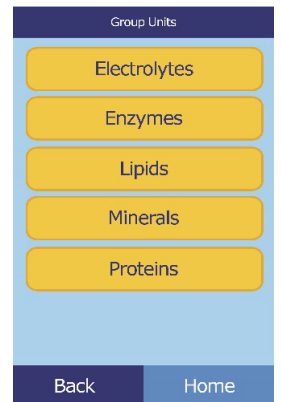

- b. Select the units to use for all lipids: **mg/dL** or **mmol/L**.

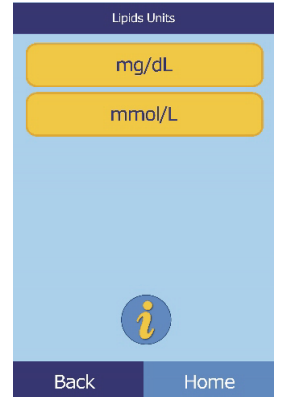

- To set units for all minerals:

a. Touch **Minerals**.

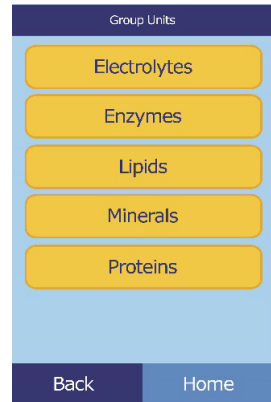

b. Select the units to use for all minerals:
mg/dL, mmol/L, or mEq/L.

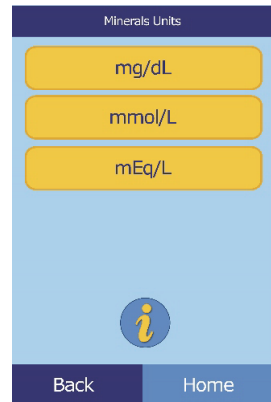

- To set units for all proteins:

a. Touch **Proteins**.

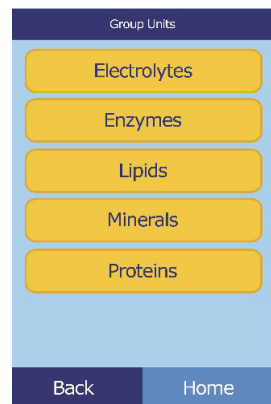

- b. Select the units to use for all proteins:
g/dL or **g/L**.

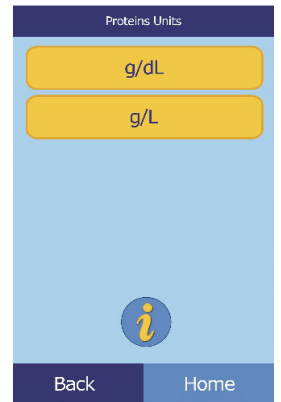

5.10 Setting Sound Volumes

Use this procedure to adjust the volume of the sounds used for the analyzer's screen click, alert, and status notification.

1. In the Home screen, touch the Settings icon.

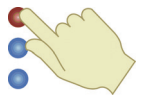

2. Touch the Sound Settings icon.

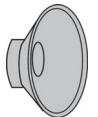

3. Select the sound to adjust.

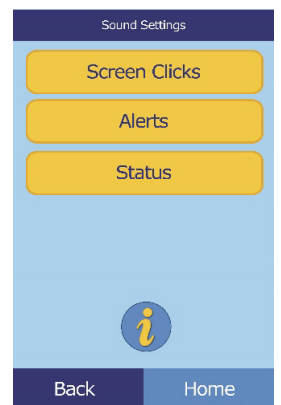

4. Use the controls to set the selected volume.

- Use the up (\triangle) and down (∇) arrow keys to adjust the volume.
- Touch **Off** to turn the sound off.
- Touch **Default** to set the sound to its factory default value.

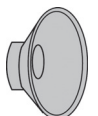

5. Touch **Save** to store the new setting.

5.11 Adjusting the Display

You can adjust the brightness of the analyzer's display as needed, and set the period that the analyzer must be inactive before it activates a screen saver or enters power-saving mode. (For either, touch the screen to wake the analyzer.)

1. In the Home screen, touch the Settings icon.

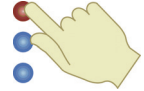

2. Touch the Display Settings icon.



3. Adjust or calibrate the display as follows.

- To adjust the backlight brightness:

- a. Touch **Back Light**.

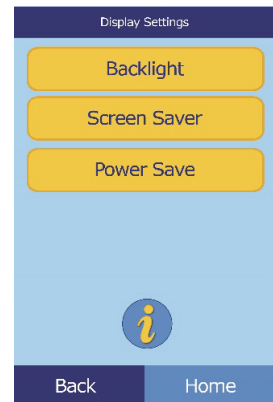

- b. Use the controls to set the brightness:

- Use the up (\triangle) and down (∇) arrow keys to adjust the brightness level.
- Touch **Full** to select maximum brightness.
- Touch **Default** to set the brightness to its factory default.

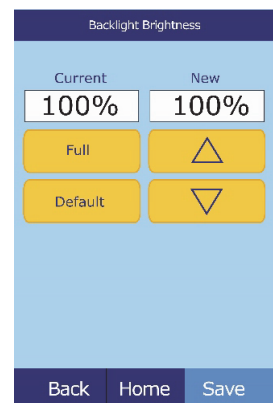

- c. Touch **Save** to store the new setting.

■ To adjust the screen saver delay:

a. Touch **Screen Saver**.

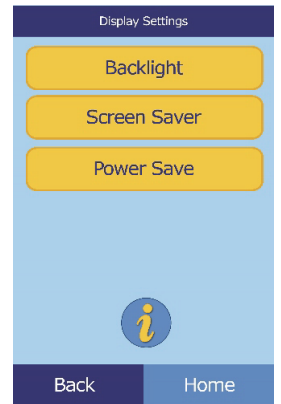

b. Use the controls to set the delay.

- Use the up (\triangle) and down (∇) arrow keys to adjust the delay.
- Touch **Never** to turn off the screen saver.
- Touch **Default** to set the delay to its factory default.

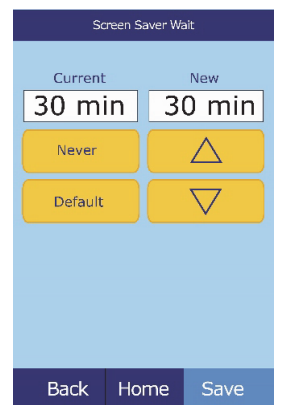

c. Touch **Save** to store the new setting.

■ To adjust power-saving delay:

a. Touch **Power Save**.

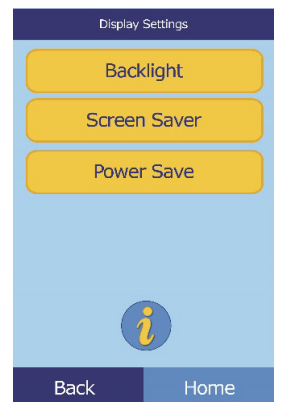

- b. Use the controls to set the delay.
 - Use the up (Δ) and down (∇) arrow keys to adjust the delay.
 - Touch **Never** to prevent the analyzer from entering power-saving mode.
 - Touch **Default** to set the delay to its factory default.
- c. Touch **Save** to store the new setting.

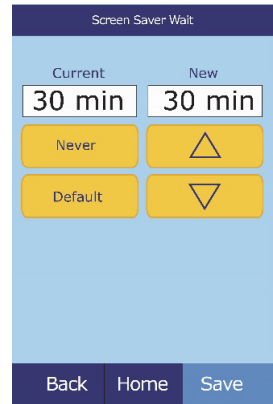

5.12 Configuring Printers

Use these procedures to set up and configure the analyzer's internal printer, or an external printer connected to the analyzer.

1. In the Home screen, touch the Settings icon.

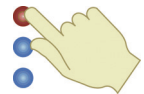

2. Touch the Printer Settings icon.

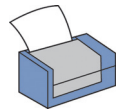

3. You can now do the following:
 - To select the default printer to be used with the analyzer, see below.
 - To test a printer for proper function, see [page 5-26](#).
 - To select which reports can be printed automatically after an analysis, see [page 5-26](#).

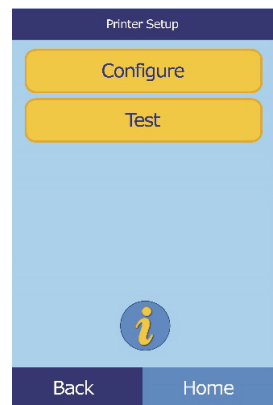

5.12.1 Setting the Default Printer

Select the printer to use for printing results and reports as follows.

1. In the Printer Setup screen, touch **Configure**.
2. Touch **Set Default**.

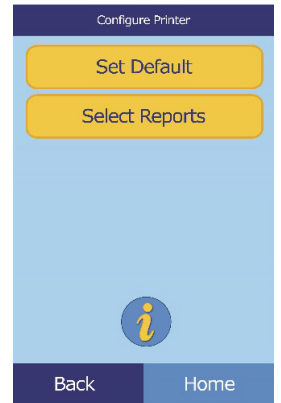

3. Select **Analyzer Printer** or **External Printer**.

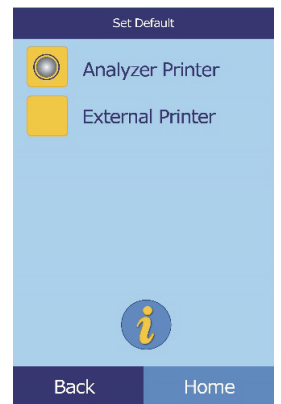

4. **For External Printer:** Select the printer from the displayed list of available printers. The analyzer then detects automatically detects the type of printer and configures it as needed.

5.12.2 Testing a Printer

Test the function of the analyzer's printer or a connected external printer as follows.

1. In the Printer Setup screen, touch **Test**.
2. Select the printer to test.

The selected printer then outputs a test page.

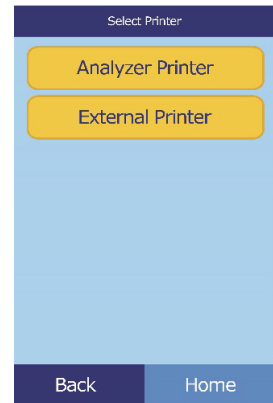

5.12.3 Printers Supported by the VetScan VS2

For a list of printers supported by the VS2 as of October 2012, see “[Supported Printers](#)” on page B-1.

Note: *Printer capabilities are subject to change without notice. For an up-to-date list of printers supported by the VetScan VS2, contact Abaxis Technical Support 24 hours a day, 7 days a week, at 1-800-822-2947.*

5.12.4 Selecting Reports

Use this procedure to set the type and number of reports that can be printed automatically after a sample is analyzed.

1. In the Printer Setup screen, touch **Configure**.
2. Touch **Select Reports**.

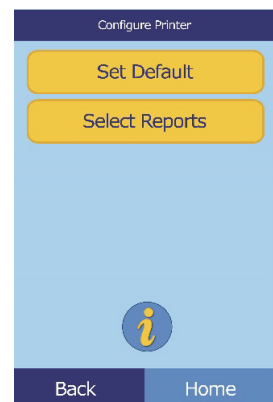

3. Select the report type.

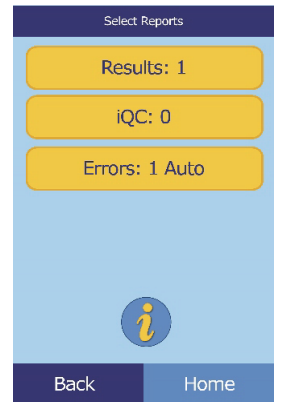

4. Use the controls to adjust the number of copies to print.

- Use the up (\triangle) and down (∇) arrow keys to adjust the number.
- Touch **Clear** to set the number to zero.
- Touch **Default** to use the factory default value.

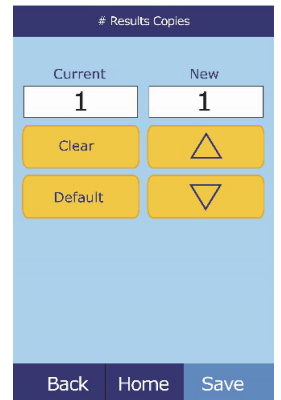

5. Touch **Save** to store the new setting.

5.13 Setting Communication Protocol

To transmit results and other information from the analyzer to an external computer, specify the communication protocol to be used.

1. In the Home screen, touch the Settings icon.



2. Touch the More Settings icon.

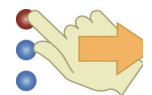

3. Touch the Communication Settings icon.

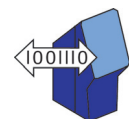

4. Select a protocol: **ASCII Text**, **None**, **ASTM**, or **XML**.

Note: *To use ASTM, contact Abaxis Technical Support 24 hours a day, 7 days week, at 1-800-822-2947.*

If you use veterinary management software, please contact your software supplier to ensure that your software is compatible with the VetScan VS2.

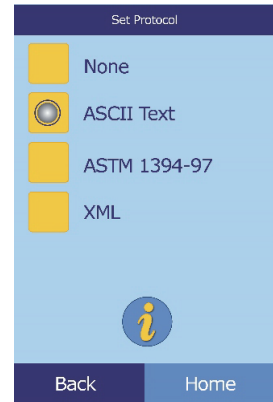

5.14 Setting Optional Advanced Functions

The VS2 includes a number of optional data-entry functions that can be used to enter more detailed information about samples, such as age and gender. The analyzer can be configured to use some or all of these functions as needed.

Note: *In this manual, screens for optional advanced functions are marked with this icon:*



However, screens for these functions appear only if the functions are enabled.

1. In the Home screen, touch the Settings icon.

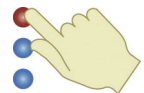

2. Touch the More Settings icon.

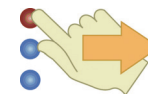

3. Touch the Advanced Settings icon.



4. In the Advanced Settings screen, select the types of information to be entered during the analysis process.

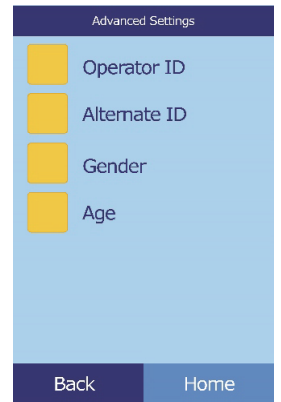

5. For Alternate ID, select the particular alternate ID item to be entered.

Use the up (\triangle) and down (∇) arrow keys to scroll through the list.

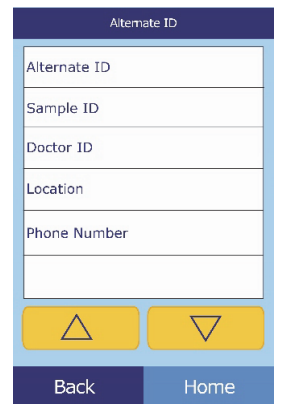

Recalling Results

The VetScan VS2 Analyzer includes a Recall function that provides access to the results of the most recent tests, including patient results, control results, and test errors.

The Recall function is available from the analyzer's Home screen.

You can search results by patient ID number or date, or view patient results or control results by date. You can also view results in memory one record at a time, print results, or transmit them to a computer.

iQC Flags

The VS2 Analyzer performs a series of internal quality checks to ensure accurate results. When the analyzer detects a problem, it either suppresses certain chemistry results (in which case it prints troubleshooting “flags” — ~~~, **HEM**, **LIP**, or **ICT** — in place of values), or cancels the run (the rotor cancels and no results are printed). When either of these situations occur, print or transmit an error report as described in [Section 6.2](#).

This section includes instructions for recalling, viewing, printing, and transmitting results and reports.

- “Recalling the Last Rotor Results” on page 6-2
- “Searching Results” on page 6-3
- “Browsing Results” on page 6-7
- “Transmitting Results” on page 6-9

Note: *The analyzer must be connected to a computer to transmit results — see “Connecting to an External Computer” on page 11-1.*

6.1 Recalling the Last Rotor Results

Use this procedure to recall, print, or transmit the results of the last rotor run.

1. In the Home screen, touch the Recall icon.
2. Touch **Last Rotor**.

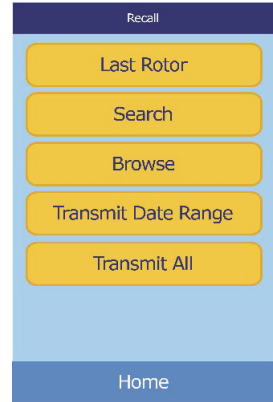

3. The results from the last rotor are displayed for review. You can use the up (Δ) and down (∇) arrow keys to scroll through the results.

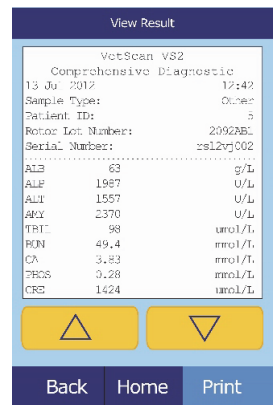

4. To print these results or transmit them to an external computer:
 - a. Touch **Print**.
 - b. Touch **Print** and/or **Transmit**.
 - c. Touch **Results**, **iQC**, **Error Report**, or **All**.

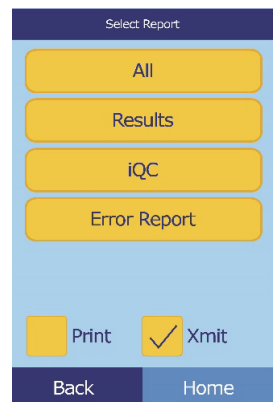

Note: *If the rotor produced no results, only **Error Report** will be available.*

The display shows “Sending Report...” while the report or results are printing or transmitting.

6.2 Searching Results

Use the Recall function to search for a particular record according to its patient ID number or date, or to view a list of all patient or control results sorted by date.

1. In the Home screen, touch the Recall icon.



2. Touch **Search**.

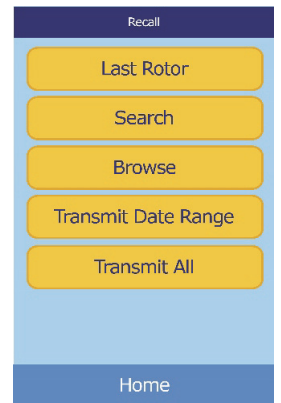

3. Use the Search screen to search for results:

- To search for results by patient/control ID, see [page 6-4](#).
- To search for results by date, see [page 6-5](#).
- To view patient results or control results sorted by date, see [page 6-6](#).

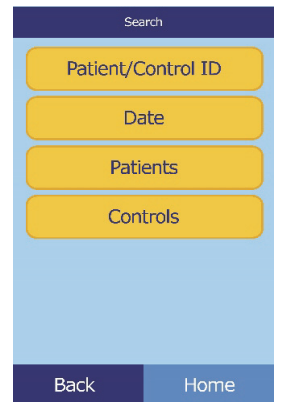

6.2.1 Searching for Results by Patient/Control ID

1. In the Search screen, touch **Patient/Control ID**.
2. Enter the patient ID number.

The right arrow key (▷) functions as a dash (–), and the left arrow key (◁) functions as a backspace.

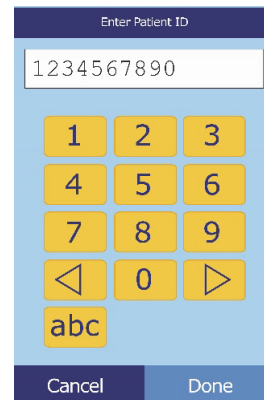

3. Touch **Search**.

The analyzer then displays a list of results (**Patient, Control, and Error**) sorted first by ID, then by date. Samples with the ID number entered are at the top, followed by the next-closest matches.

Use the up (△) and down (▽) arrow keys to scroll through the list. (The list wraps around when either end is reached.)

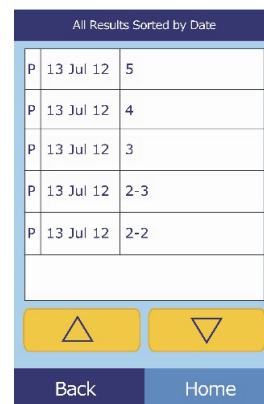

P	13 Jul 12	5
P	13 Jul 12	4
P	13 Jul 12	3
P	13 Jul 12	2-3
P	13 Jul 12	2-2

4. Touch to select and display the particular results.

Use the up (△) and down (▽) arrow keys to scroll through the results.

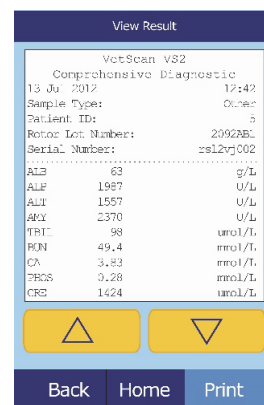

ABE	63	g/L
ALB	1987	U/L
ALT	1557	U/L
APX	2370	U/L
TRIC	98	umol/L
BUN	49.4	mmol/L
CA	3.83	mmol/L
PHOS	0.28	mmol/L
CRE	1424	umol/L

5. To print these results or transmit them to an external computer:
 - a. Touch **Print**.
 - b. Touch **Print** and/or **Transmit**.
 - c. Touch **Results**, **iQC**, **Error Report**, or **All**.

The display shows Sending Report... while the report or results are printing or transmitting.

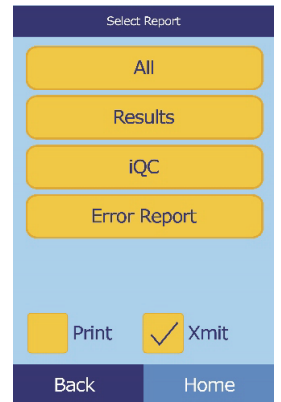

6.2.2 Searching for Results by Date

1. In the Search screen, touch **Date**.
2. Enter the date of the results.

Use the up (\triangle) and down (∇) arrow keys to adjust the day, month, and year.



3. Touch **Search**.

The analyzer then displays a list of results in reverse chronological order, beginning with the date entered.

Use the up (\triangle) and down (∇) arrow keys to scroll through the list.

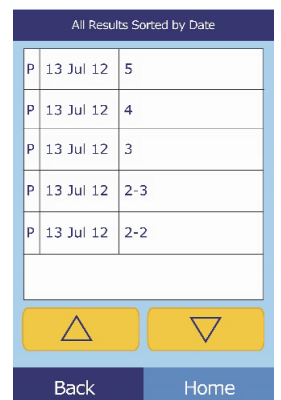

4. Touch to display the results.

Use the up (\triangle) and down (∇) arrow keys to scroll through the results.

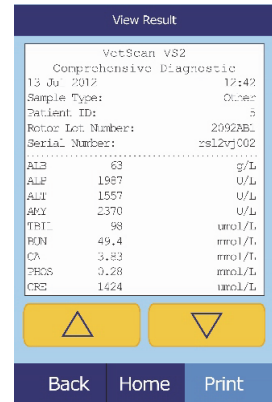

5. To print these results or transmit them to an external computer:

- a. Touch **Print**.
- b. Touch **Print** and/or **Transmit**.
- c. Touch **Results**, **iQC**, **Error Report**, or **All**.

The analyzer displays Sending Report... while the report or results are printing or transmitting.

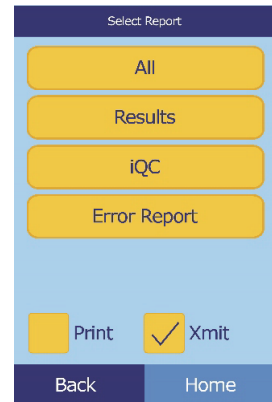

6.2.3 Viewing Patient Results or Control Results by Date

1. In the Search screen, touch **Patients** or **Control**.

The analyzer then displays a list of **Patient** results and **Errors** (shown at right) or **Control** results and **Errors** (far right) in reverse chronological order, beginning with the date entered.

Use the up (\triangle) and down (∇) arrow keys to scroll through the list.

Patient Results Sorted by Date		
P	13 Jul 12	5
P	13 Jul 12	4
P	13 Jul 12	3
P	13 Jul 12	2-3
P	13 Jul 12	2-2

Control Results Sorted by Date		
C	13 Jul 12	5
C	13 Jul 12	4
C	13 Jul 12	3
C	13 Jul 12	2-3
C	13 Jul 12	2-2

2. Touch to display the results.

Use the up (Δ) and down (∇) arrow keys to scroll through the results.

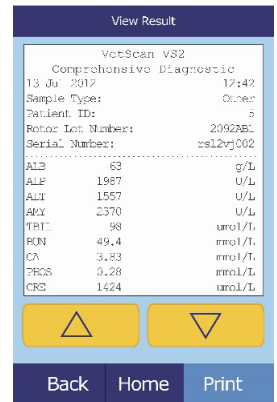

View Result

VetScan VS2
Comprehensive Diagnostic
13 Jul 2012 12:42
Sample Type: Other
Patient ID: 5
Rotor Lot Number: 2092ABL
Serial Number: zsl2vj002

ALP	63	g/L
ALP	1987	U/L
ALT	1557	U/L
AKY	2370	U/L
TPTT	98	uro1/L
BUN	49.4	mmol/L
CA	3.83	mmol/L
PHOS	0.28	mmol/L
CRE	1424	uro1/L

Δ ∇

Back Home Print

3. To print these results or transmit them to an external computer:

- a. Touch **Print**.
- b. Touch **Print** and/or **Transmit**.
- c. Touch **Results**, **iQC**, **Error Report**, or **All**.

The analyzer displays **Sending Report...** while the report or results are printing or transmitting.

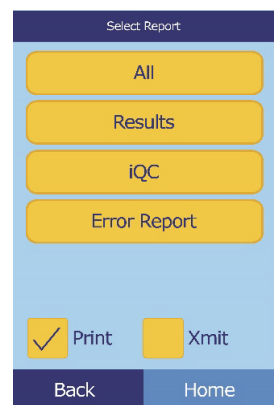

6.3 Browsing Results

Use the Recall function to browse through all stored results.

1. In the Home screen, touch the Recall icon:
2. Touch **Browse**.

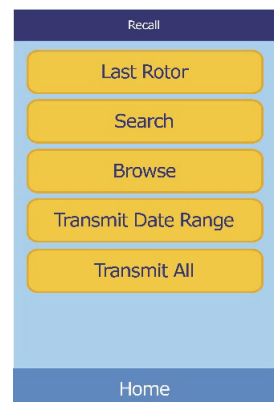

The analyzer then displays a list of all results (**Patient**, **Control**, and **Error**) in reverse chronological order, beginning with the date entered.

Use the up (\triangle) and down (∇) arrow keys to scroll through the list and find the needed results.

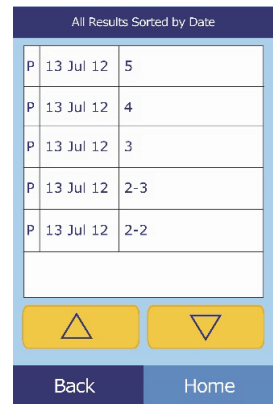

3. Touch to display the results.

Use the up (\triangle) and down (∇) arrow keys to scroll through the results.

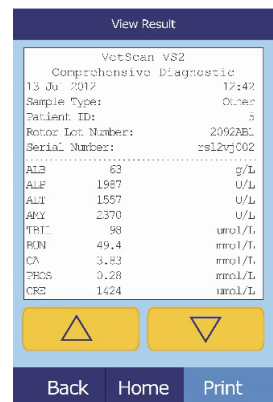

4. To print these results or transmit them to an external computer:

- a. Touch **Print**.
- b. Touch **Print** and/or **Transmit**.
- c. Touch the report: **Results**, **iQC**, **Error Report**, or **All**.

The display shows “Sending Report...” while the report or results are printing or transmitting.

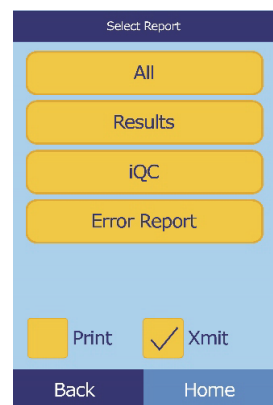

6.4 Transmitting Results

Use this procedure to transmit all stored results to a computer.

Note: *The analyzer must be connected to a computer to transmit results — see “Connecting to an External Computer” on page 11-1.*

1. In the Home screen, touch the Recall icon.



2. Touch **Transmit All**.

The analyzer displays “Transmitting All...” while sending the records.

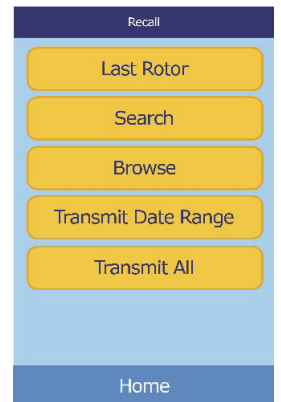

Calibration and Quality Control

7.1 Calibration

The VetScan VS2 Analyzer is self-calibrating. A bar code on the reagent rotor contains the information needed to calibrate the rotor when run. Additionally, each reagent bead used in the rotor is calibrated to a reference method and/or reference material. This and the procedures in the previous sections of this manual help ensure accurate results.

7.2 Quality Control Features

The analyzer includes quality control features such as optical sensing and electronic feedback systems, to ensure that accurate results are reported. The analyzer tests its internal components and the reagent rotors whenever the power is turned on or a rotor is inserted. Additionally, the analyzer continues to perform tests during analysis. Messages shown on the display or printed in the results warn of analyzer malfunctions and possible errors, or explain why no results are reported.

1. Intelligent Quality Control (iQC)

The analyzer performs an iQC test whenever power is turned on. iQC ensures that all optics, flash, and circuit board components are functioning properly and verifies the memory functions. The analyzer performs analysis only after iQC confirms that all components are functional. A hardware malfunction message appears on the display if any component malfunctions.

The analyzer's software incorporates statistical methods to ensure accurate results. The lamp flashes up to 13 time points for rate chemistries, and typically three time points for endpoint chemistries. To ensure that the analyzer is functioning properly, the distribution of flashes at each time point is analyzed, and the standard deviation is compared to a pre-determined limit.

2. **Quality Control During Analysis**

During analysis, the analyzer checks its internal components and the reagent rotor to ensure the accuracy of the results.

a. **Analyzer**

Before analysis begins, the analyzer's photometer takes readings with the light path obstructed and unobstructed to determine the appropriate light intensity range, and then checks that the range is within specification. It also continually checks the performance of the motor, flash, and optics during analysis.

b. **Reagent Rotor**

During analysis, the analyzer tests the reagent rotor to confirm the following:

- calibration factors
- expiration date
- all reagent beads are present
- timing of fluid movement through the rotor
- diluent and sample mixing
- sufficient sample in the rotor
- reagent beads dissolve when mixed with diluted sample

Each rotor contains reagents to detect exposure to extreme conditions such as temperature and humidity. The message QC OK is printed in the results when results from these reagents are within the expected ranges. Otherwise, no results are printed and a "run canceled" message appears in the display.

The analyzer monitors the performance of the reactions. For rate chemistries, the analyzer confirms that the reactions are linear with time, that the slope is within range, and whether the substrate has been depleted. In endpoint chemistries, the analyzer verifies the flatness (completeness) of the endpoints.

c. **Sample**

Samples are checked for physical interference. The analyzer estimates the sample indices, hemolysis, lipemia, and icterus using absorbance readings for the sample at 340 nm, 405 nm, and 467 nm. This information is then compared to pre-established hemolysis, lipemia, and icterus limits for each method. When all three indices are below these limits for the method, that method's results are printed. When any index exceeds the limit, the result is suppressed and the error condition displayed as HEM, LIP, or ICT.

7.3 Running Controls

A control is a biological sample or solution with a suitably contrived matrix that is analyzed for purposes of quality control. The composition of the matrix must be such that the solution closely matches that of the biological specimen for characteristics of importance to the analyzer. Control materials need to be stable and available in sufficient volumes in multiple portions and over an extended period. Many control products are available commercially. Assayed controls also come with expected values of the analytes for guidance.

The VS2 includes an extensive iQC program that eliminates the need for routine external liquid controls. If an external control is needed occasionally, the analyzer provides a memory bank to store that data. The control must have a composition closely matching that of the biological specimen in characteristics important to analysis. Control materials must be available in sufficient volumes and multiple portions, and stable over an extended period. Many control products are available commercially. Assayed controls also include expected analytes values for guidance.

The Run Controls menu function automatically stores control results in a memory separate from the patient results memory. The Recall function may be used to search for specific control results without searching through all patient results stored in memory.

Note: *Before a control can be run, a control level must be enabled in the reference ranges — see page 5-6.*

Controls can be run whenever the analyzer displays the Home screen.

Note: *Always wear personal protective equipment (gloves, safety glasses, lab coat) when running any control containing components derived from human sources. The gloves should be powder free to avoid getting powder on the analyzer optics.*

For more details on running an analysis, see “Running Tests” on page 4-4.

1. In the Home screen, touch **Analyze** to open the rotor drawer.
2. Insert the control sample into the reagent rotor (see “Running Tests” on page 4-4), and place the rotor into the drawer.
3. Touch **Close** to close the drawer and start analysis.

4.  Enter the Operator ID using the touchscreen, then touch **Done**.

The operator ID is a number of up to 14 digits that is assigned by the facility.

The right arrow key (▷) functions as a dash (–), and the left arrow key (◁) functions as a backspace.

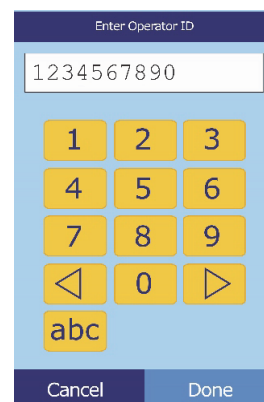

5. Select the control type to use.

Use the up (△) and down (▽) arrow keys as needed to scroll through the list.

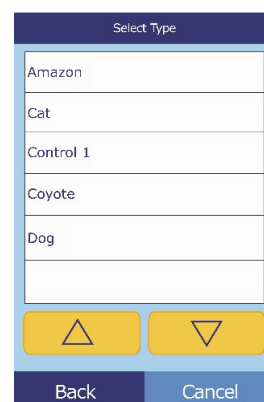

6. Enter an ID number for the sample (up to 14 characters), then touch **Done**.

The right arrow key (▷) functions as a dash (–), and the left arrow key (◁) functions as a backspace.

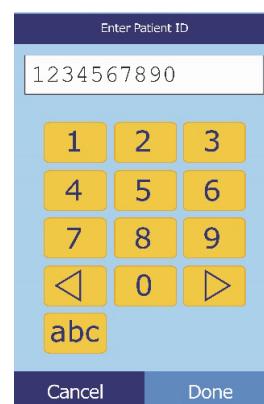

7.  Enter an alternate ID (up to 14 characters), then touch **Done**.

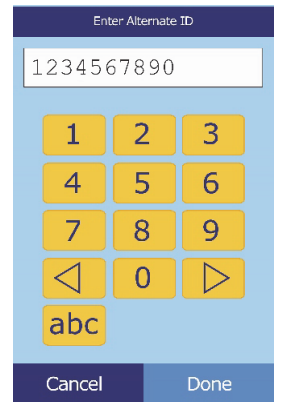

8. The analyzer checks the rotor type, then begins processing the sample with no further input.

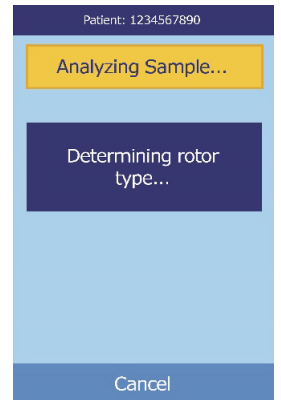

9. The analyzer indicates when the sample is finished processing, then automatically prints the results of the analysis.

If the results do not print automatically, they can be recalled from memory and printed — see “[Searching Results](#)” on page 6-3.

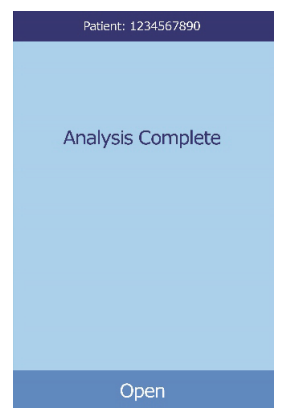

10. Touch **Open** to open the rotor drawer, and remove the reagent rotor from the drawer.

CAUTION: *Dispose of the rotor according to the lab's biohazard procedures.*

11. When finished, touch **Close** to close the drawer.

Troubleshooting

8.1 Using Analyzer Messages

If problems occur, the analyzer can display warnings, iQC codes, and other messages to help diagnose the problem.

Use the information in this section, and in “Using iQC Codes for Troubleshooting” on page A-1 for help in resolving these errors.

8.2 Contacting Abaxis Technical Support

If the troubleshooting recommendations contained in this section do not correct the problem with the analyzer or the reagent rotors, record the error message and/or print an error report and contact Abaxis Technical Support, 24 hours a day, 7 days a week, at 1-800-822-2947, or send a fax to 1-877-900-9333.

8.3 Instrument and Result Messages

The VS2 Analyzer performs a series of internal quality checks to ensure accurate results. When the analyzer detects a problem, the analyzer will either suppress certain chemistry results (~~~, **HEM**, **LIP**, or **ICT** printed in place of values) or cancel the run (rotor cancels and no patient results printed). If either of these situations occurs, proceed as follows:

8.3.1 Chemistry Suppression

In this situation, patient results print, but some results do not have numerical values. The results printout includes troubleshooting “flags” — **HEM**, **LIP**, **ICT**, or the symbols ~~~ — in place of values.

Contact Abaxis Technical Support at 1-800-822-2947 to review the patients results printed on the error report. You can print the error report using the Recall function starting from the Home screen. See “[Recalling Results](#)” on page 6-1.

Disclaimer: Note that “~~~” is printed in the results for an individual chemistry when the instrument iQC detects a possible fault condition in the chemistry reading or calculation. If this happens, contact Abaxis Technical Support for error report interpretation and further instructions on testing the sample.

8.3.2 Rotor Cancellation

In this situation:

1. The display shows Run Canceled and no patient results are printed.
2. The display also shows an iQC code and a brief description of the problem.

Record the iQC code, and print an iQC code report using the Recall function, which can be accessed from the Home screen. For details about printing these reports, see “[Recalling Results](#)” on page 6-1.

8.3.3 Symbols on the Results Printout

These symbols print next to the result (see “[Running Tests](#)” on page 4-4):

- * The result is outside the reference range.
- < The result is lower than the dynamic range.
- > The result is higher than the dynamic range.

To obtain more information for results that have < or > printed before the value, print an error report (see “[Recalling Results](#)” on page 6-1). This report includes patient results, but the values are an approximation of the analyte concentration.

In addition, these symbols (“flags”) are printed when a result is not available:

~~~	Chemistry interference
HEM	Hemolysis interference
LIP	Lipemia interference
ICT	Icterus interference

To obtain more information for results with (H) HEM, (L) LIP or (I) ICT, print an error report (see “[Recalling Results](#)” on page 6-1). The error report shows a value with **HEM**, **LIP** or **ICT** next to it.

The entire numerical line displayed on the error report, including the line HEM, LIP, and ICT, must be interpreted by an Abaxis Technical Support Representative to determine whether results are usable. Call Abaxis Technical Support at 1-800-822-2947.



## 8.4 Rotor Cancellations and Procedures

If the rotor cancels, record the following information or print an error report, and contact Abaxis Technical Support at 1-800-822-2947:

- Lot number
- Product name
- 4-digit error code
- Specimen type and species

## 8.5 Reinitializing the Analyzer

The analyzer may require reinitialization if its memory becomes corrupted. Reinitializing returns all settings to their original factory default values, and erases custom reference ranges from memory. Perform the following steps to reinitialize the analyzer.

1. In the Home screen, touch the Settings icon.



2. Touch the More Settings icon.

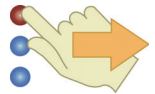

3. Touch the Factory Settings icon.

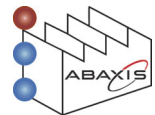

4. Archive the analyzer's reference ranges — including custom reference ranges — so they can be restored after the analyzer is reinitialized. For instructions, see [“Printing and Archiving Reference Ranges”](#) on page 5-10.

**Note:** *The next step is irreversible. All settings — including custom reference ranges — are returned to their factory values, and the memory is cleared. Results previously stored, however, are not affected.*

5. Touch **Continue** to restore all factory settings.

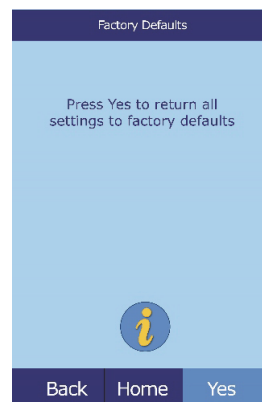

6. Refer to the sections noted below to reset the date and time, any custom reference ranges, and the units of measurement:
  - “Customizing Reference Ranges” on page 5-2
  - “Changing Date and Time” on page 5-14
  - “Selecting Units” on page 5-16

# Principles of Procedure and Operation

## 9.1 Principles of Procedure

The operator introduces a heparinized whole blood sample (or heparinized plasma, serum, or control) into the reagent rotor. The reagent rotor contains a diluent, and test-specific reagent beads. The operator then places the rotor in the VetScan VS2 Chemistry Analyzer and enters the appropriate identification numbers. The VS2 Analyzer automatically performs the remainder of the testing protocol.

The reagent rotor spins and whole blood is separated into plasma and blood cells. During this time, the rotor is heated to 37 °C (98.6 °F). Precisely measured quantities of plasma and diluent enter the mixing chamber and are combined. Centrifugal and capillary forces distribute the diluted plasma to cuvettes on the perimeter of the rotor. Reagent beads in the cuvettes are dissolved by the diluted plasma. This solution is thoroughly mixed, and the resulting chemical reactions are monitored photometrically by the analyzer. Optical signals generated by the chemical reactions are used to calculate analyte concentrations. Calibration data specific for the chemistries in each rotor are provided to the analyzer by the bar code printed on the bar code ring.

After analysis is complete, the results print automatically, and include analyte concentrations and reference ranges for each test in the panel, as well as sample indices. Results are also stored in the analyzer's memory and can be transmitted to external computers. The used reagent rotor is removed and discarded. The VS2 is ready to analyze another sample.

## 9.2 Principles of Operation

Chemical reactions occur between reagent beads, the diluent contained in the reagent rotor, and the added sample. These reactions produce chromophores that are measured photometrically by the VS2. The microprocessor then calculates the concentrations of the analytes.

The measurement optics include a stroboscopic xenon lamp, a wavelength selection system, and a multiple-wavelength detector. Light from the lamp is directed by a mirror to pass through each cuvette. Some light is absorbed by the cuvette contents, and the remainder travels through two apertures and is then collimated by a lens. The collimated light is divided by beam splitters, passed through interference filters at wavelengths of 340, 405, 467, 500, 515, 550, 600, 630, and 850 nm, and measured at each wavelength by photodiodes.

The chemical reactions used in the tests produce chromophores that absorb light at known wavelengths. The photometer measures the light transmitted through each chromophore-containing cuvette (the reaction cuvette). This transmitted light, when corrected for flash-to-flash variability and electronic offset, is indirectly related to the analyte concentration of the sample. Transmittance measurements are then converted to absorbance according to the relationship  $\text{absorbance} = \log(\text{transmittance})$ .

System errors and factors that can interfere with sample result calculations are eliminated by measuring light intensity at four locations on the reagent rotor: the method-specific cuvette containing test reagent, sample, and diluent; the sample blank cuvette containing sample blank reagent, sample, and diluent (used in endpoint reactions — see below); the open cuvette, which allows all light to pass through; and the dark cuvette, which blocks the passage of light.

Light passing through a reaction cuvette is measured at the wavelength absorbed by the chromophore ( $I_{\lambda 1RC}$ ), and also at a wavelength not absorbed by the chromophore ( $I_{\lambda 2RC}$ ). The ratio of these two measurements corrects for cuvette optical quality and flash-to-flash variability in the light source. The intensity of light transmitted through the open cuvette ( $I_{\lambda 1OC}$ ,  $I_{\lambda 2OC}$ ) is measured at the same two wavelengths as the light transmitted through the reaction cuvette. A correction for electronic offset is made at the same two wavelengths by measuring the residual signal when the dark cuvette is in the optical path ( $I_{\lambda 10}$ ,  $I_{\lambda 20}$ ).

The equation for calculating absorbance is this:

$$A = -\log \left[ \frac{(I_{\lambda 1RC} - I_{\lambda 1_0}) / (I_{\lambda 2RC} - I_{\lambda 2_0})}{(I_{\lambda 1OC} - I_{\lambda 1_0}) / (I_{\lambda 2OC} - I_{\lambda 2_0})} \right]$$

where:

- A = Absorbance at wavelength 1, referenced to wavelength 2
- $I_{\lambda 1RC}$  = Intensity of light transmitted through the reaction cuvette at wavelength 1
- $I_{\lambda 2RC}$  = Intensity of light transmitted through the reaction cuvette at wavelength 2
- $I_{\lambda 1_0}$  = Intensity of light transmitted through the dark cuvette at wavelength 1
- $I_{\lambda 2_0}$  = Intensity of light transmitted through the dark cuvette at wavelength 2
- $I_{\lambda 1OC}$  = Intensity of light transmitted through the open cuvette at wavelength 1
- $I_{\lambda 2OC}$  = Intensity of light transmitted through the open cuvette at wavelength 2

This is the basic equation for measuring analyte concentrations in the rate methods and endpoint reactions used in chemistries.

### 9.2.1 Rate Methods

The rate of the reaction is calculated from the difference between absorbances measured at certain defined intervals on the linear portion of the reaction curve. Absorbances are taken throughout the read time to confirm the linearity of the reaction curve. The absorbance rates are converted to analyte concentrations using the rotor-specific calibration factors encoded on the bar code ring.

The equation for rate methods is:

$$\frac{\left\{ -\log \left[ \frac{(I_{\lambda 1RC} - I_{\lambda 1_0}) / (I_{\lambda 2RC} - I_{\lambda 2_0})}{(I_{\lambda 1OC} - I_{\lambda 1_0}) / (I_{\lambda 2OC} - I_{\lambda 2_0})} \right]_F \right\} - \left\{ -\log \left[ \frac{(I_{\lambda 1RC} - I_{\lambda 1_0}) / (I_{\lambda 2RC} - I_{\lambda 2_0})}{(I_{\lambda 1OC} - I_{\lambda 1_0}) / (I_{\lambda 2OC} - I_{\lambda 2_0})} \right]_B \right\}}{\text{Time Period}}$$

where:

- $\Delta A / \Delta t$  = Rate of change of absorbance
- F = Measurements taken at time F on linear portion of reaction curve
- B = Measurements taken at time B on linear portion of reaction curve
- t = Time in minutes
- $I_{\lambda XX}$  = Other intensities, same as described above

## 9.2.2 Endpoint Reactions

Reagents, samples, and chromophores all absorb light in endpoint reactions. Light absorption by the samples must be subtracted so that the analyte concentration can be isolated. The absorbance of the sample is measured in a sample blank cuvette. Some chemistries employ a generic sample blank and others (such as total bilirubin) use a dedicated sample blank. The intensity of the light passing through the sample blank cuvette ( $I_{\lambda 1SC}$ ,  $I_{\lambda 2SC}$ ) is measured at the same wavelengths as is the light passing through the reaction cuvette.

The equation for endpoint reactions is:

$$A = -\log \left[ \frac{(I_{\lambda 1RC} - I_{\lambda 1_0}) / (I_{\lambda 2RC} - I_{\lambda 2_0})}{(I_{\lambda 1OC} - I_{\lambda 1_0}) / (I_{\lambda 2OC} - I_{\lambda 2_0})} \right]$$

where:

$I_{\lambda 1SC}$  = Intensity of light transmitted through the sample blank cuvette at wavelength 1

$I_{\lambda 2SC}$  = Intensity of light transmitted through the sample blank cuvette at wavelength 2

$I_{\lambda XX}$  = Other intensities are the same as described above

The net absorbance is converted to analyte concentration using data encoded in the bar code printed on the bar code ring.

# Maintenance and Service

The VetScan VS2 Analyzer requires minimal maintenance. Clean the exterior of the analyzer weekly with mild detergent and a soft, damp cloth. The air filter requires cleaning once a month. Regular maintenance of the analyzer will assure reliable operation.

**CAUTION:** *Abaxis recommends only the cleaning methods described in this section. If for some reason another method is needed, contact Abaxis Technical Support beforehand at 1-800-822-2947 to verify that the proposed method will not damage the analyzer. Abaxis is not responsible for damage caused by non-recommended cleaning methods.*

## 10.1 Cleaning the Analyzer

Clean the analyzer's external case and display at least weekly, as described below.

### 10.1.1 Cleaning the Case

Clean the analyzer with a soft cloth, dampened with a mild, non-abrasive detergent or cleaning solution, such as Simple Green[®], a 10% bleach solution, or a 30% isopropyl alcohol solution. Pre-soaked towelettes (isopropyl alcohol) may be used as an alternate. Purchase isopropyl towelettes from computer retailers.

Do not spray or pour any detergents, solutions or other liquids directly onto the analyzer. Dampen a soft cloth or disposable paper towel with the detergent, then apply to the analyzer.

**Note:** *While cleaning, inspect the analyzer's casing to make sure it is not cracked or damaged.*

## 10.1.2 Cleaning the Display

Clean the analyzer's screen periodically using a soft, lint-free cloth dampened with a glass-cleaning fluid or window cleaner.

**CAUTION:** Do not use any cleaner containing alcohol. Do not spray cleaner directly onto the display — dampen the cloth instead.

## 10.2 Cleaning Spills

Observe universal precautions¹ when cleaning spills on the analyzer. Use a 10% bleach solution (1 part bleach plus 9 parts water) to clean spills, following the standard cleaning guidelines in “Cleaning the Analyzer” on page 10-1.

## 10.3 Cleaning the Air Filter

Clean the air filter in the back of the analyzer at least monthly, or as needed to ensure proper ventilation and temperature control of the instrument. Check the filter frequently if the analyzer is in an environment with excessive dust or animal hair.

**Note:** For replacement filters, contact Abaxis Customer Service (1-800-822-2947, during regular business hours).

1. Turn the analyzer off by pressing and holding the Power button.
2. Remove the power cord and filter cover from the back of the analyzer.
3. Remove the filter.
4. Wash the filter with warm water to remove dust, animal hair, and any other debris.
5. Dry the filter and place it back into the analyzer.

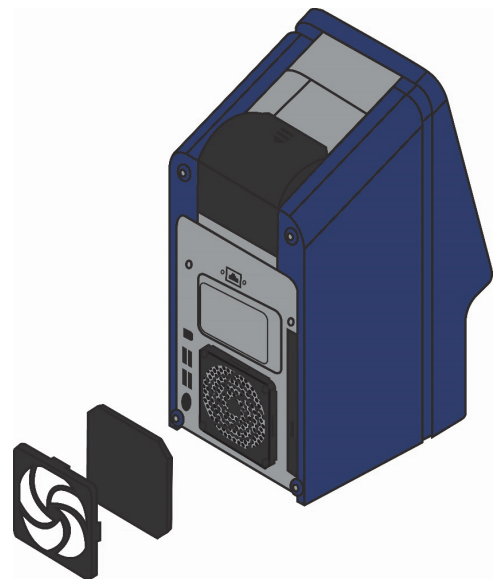

**CAUTION:** Make sure the filter is **completely** dry before replacing it.

1. National Committee for Clinical Laboratory Standards (now Clinical and Laboratory Standards Institute). 1992. Physician's office laboratory guidelines, 2nd ed; tentative guideline. NCCLS document POL1-T2 (ISBN 1-56238-159-8). Villanova, PA: NCCLS; pp. A27–A28.



6. Snap the filter cover back into place over the filter.
7. Plug the power cord into the back of the analyzer.
8. Press the Power button. The analyzer then performs a diagnostic self test, and may take a few minutes to bring the rotor chamber to operating temperature.

**Note:** Refer to “*Troubleshooting*” on page 8-1 if the analyzer does not successfully pass the self test after cleaning the air filter. See “*Running Tests*” on page 4-4 for instructions on running samples.

## 10.4 Updating the Analyzer Software

Abaxis provides software updates on CD-ROM to registered owners of the VetScan VS2 Analyzer. Replacement software is mailed immediately whenever a new software version is released. See “*Viewing Analyzer Identification*” on page 5-13 to determine the software version installed in the analyzer. Contact Abaxis Technical Support immediately at 1-800-822-2947 if the software version is not the most recent release.

**Note:** Be sure to update the software every time you receive an update CD from Abaxis.

**CAUTION:** Updating software can return the VS2 to its default settings, and delete any stored records and custom reference ranges. Before beginning the update, make sure you archive your data. For instructions, see Section 5.3, “*Printing and Archiving Reference Ranges,*” on page 5-10.

*You will also have a chance to cancel the procedure after beginning.*

*Contact Abaxis Technical Support for information on software updates and how they can affect your VS2.*

1. In the Home screen, touch the Settings icon.

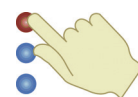

2. Touch the More Settings icon.

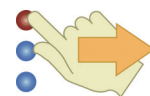

3. Touch the Software Update icon.

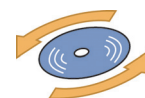

4. Place the CD in the drawer, press the drawer in to close it, then touch **Continue**.

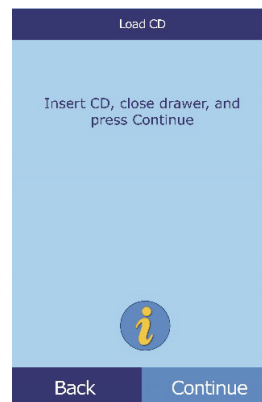

5. The update then begins.

When the update is complete, the analyzer automatically shuts down and restarts.

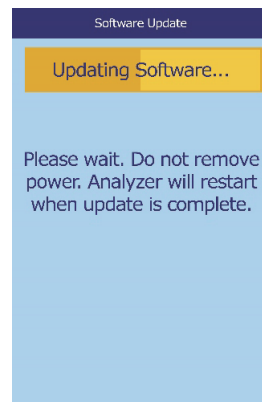

**CAUTION:** Do not remove the CD until after the analyzer shuts down and restarts to complete the software update, or you could damage the analyzer.

## 10.5 Returning the Analyzer for Service

Before sending the analyzer in, you must obtain authorization for service: call Abaxis Technical Support, 24 hours a day, 7 days a week, at 1-800-822-2947.

# Connecting to an External Computer

The VetScan VS2 Analyzer is equipped to transmit patient and control results in 8-bit, ASCII (American Standard Code for Information Interchange) format to a computer through a USB port. To receive the results from the VS2, the computer requires terminal emulation software, such as HyperTerminal, which is included with Windows 95 and higher. The computer also requires driver software to communicate with the VS2.

The results can be captured to a text file to be viewed with most word processing, spreadsheet, and database applications. This section describes the transmission specifications, hardware connections, and use of HyperTerminal to capture results to a text file.

**Note:** *Veterinary management software can also interface with the VS2 to collect results. Since each such installation varies, contact your software supplier for more information.*

## 11.1 Transmission Specifications

<b>Cable:</b>	USB cable
<b>Baud rate:</b>	9600
<b>Data type:</b>	ASCII
<b>Parity:</b>	None
<b>Word length:</b>	8 bits
<b>Stop bit:</b>	1
<b>Start of transmission and new page sentinel:</b>	Form Feed (decimal 12 or hexadecimal 0C)
<b>End of line sentinel:</b>	Carriage Return (decimal 13 or hexadecimal 0D) and Line Feed (decimal 10 or hexadecimal 0A)
<b>End of transmission sentinel:</b>	End-of-File (decimal 26 or hexadecimal 1A)
<b>Max number characters/line:</b>	32 (including Carriage Return and Line Feed)

**Note:** The exact contents of the printed results are transmitted. In some cases a backslash (\) should be interpreted as a foreslash (/). For example, “mmo\L” is equivalent to “mmol/L” and “mmo\L” is “mmol/L” in the transmitted results.

## 11.2 Enabling the VetScan VS2 Communication Protocol

The VetScan VS2 can communicate with computers running Microsoft Windows, Macintosh OS X, or Linux (kernel 2.4 or above).

To enable this communication, set the VS2’s communication protocol as follows:

1. Follow steps 1 through 3 of “[Setting Communication Protocol](#)” on page 5-27.
2. In the Set Protocol screen, select **ASCII Text**.

**Note:** If you use veterinary management software, please contact your software supplier to ensure that your software is compatible with the VetScan VS2.

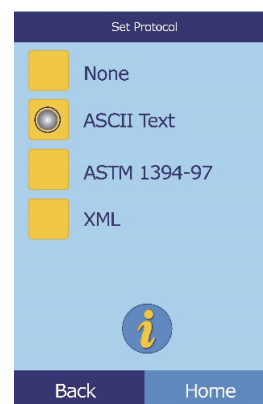

## 11.3 Installing the Windows Driver

*Note:* For Windows Vista, see “Installing the Windows Vista Driver” on page 11-7.

Use this procedure to install the Abaxis driver that enables the analyzer to communicate with a PC running the Windows operating system. The analyzer installs on the PC as a virtual communication port in Windows.

Installation requires the following:

- VetScan VS2 Analyzer
- PC running Windows, and with a free USB port
- Type A/Type B USB cable
- Abaxis Driver CD (software files: P/N 110-5001)

*Note:* Driver installation in Windows requires a user account with administrative privileges.

*The screenshots in these instructions are from a typical Windows XP Professional installation. Some of these screens may vary on your system and in other versions of Windows.*

Install the driver as follows.

1. Insert the Abaxis Driver CD into the computer’s CD drive.
2. The computer’s default web browser then opens, displaying the VS2 driver installation guide links. Close the browser.
3. Go to **Start > My Computer** to display the computer’s drives.
4. Right-click the CD drive icon, and select **Explore** from the pop-up menu.

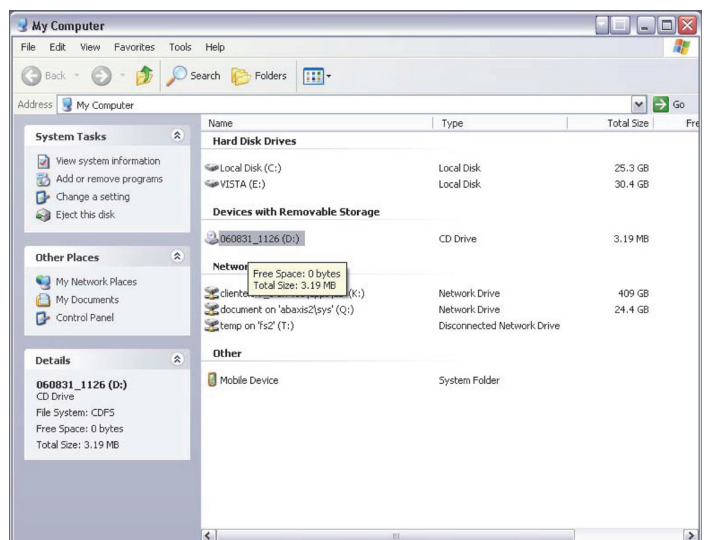

5. Open the **Win2K_XP** folder.

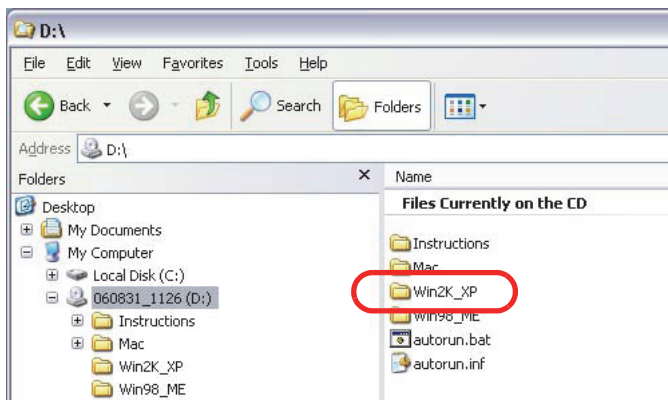

6. Double-click the file **Abaxis Driver Setup.exe**.

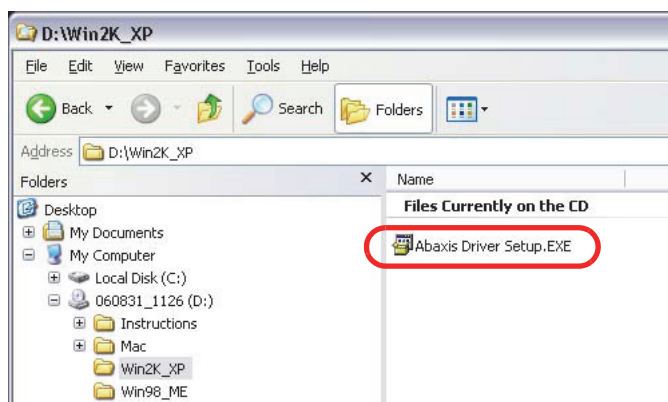

7. Installation then begins. When the installer finishes, click **OK**.

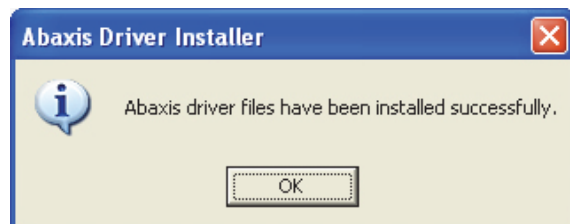

8. Use the USB cable to connect the VS2 to any available USB port on the computer.
9. Click **Start > Control Panel > System**, then click the **Hardware** tab.
10. Click **Device Manager**, then click the “+” before **Ports (COM & LPT)**. Look for **Abaxis Blood Chemistry Analyzer**.

**Note:** *If the analyzer does not appear in the device list, **do not** reinstall the driver. Unplug the USB cable from the computer, then reinsert it. Check the device manager again.*

- Note the port number to which the analyzer is assigned, and record this number. You will use this port number later in this procedure.

(In the example at right, the port is COM4.)

- Close the Device Manager.

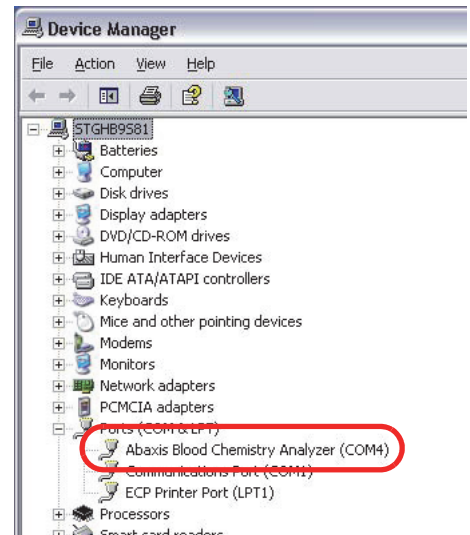

- Click **Start > Run**, and in the dialog enter **hypertrm**.

This opens the HyperTerminal window.

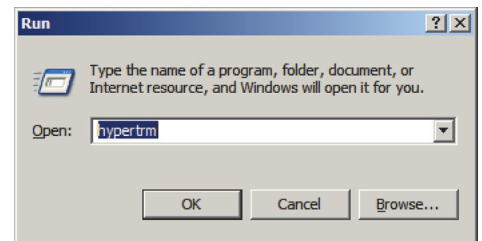

- In the Connection Description dialog, enter **VS2**, then click **OK**.

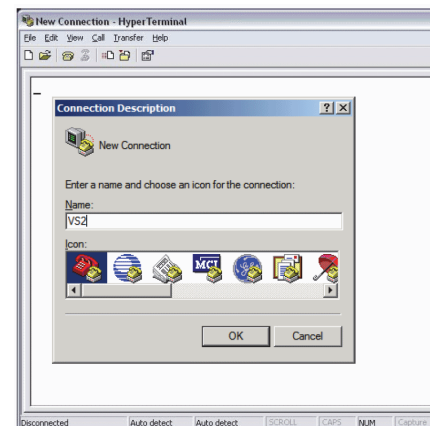

- In the Connect To dialog that opens, use the **Connect using** pull-down menu to select the COM port you found earlier.

- Click **OK**.

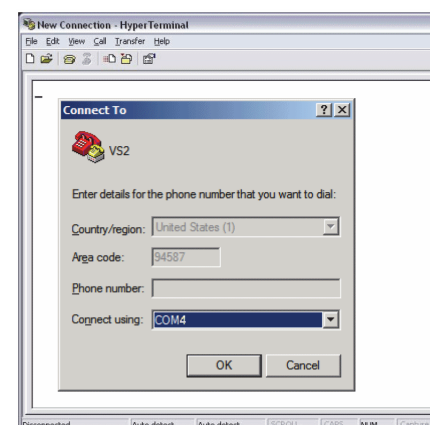

17. In the COM Properties dialog, use the **Bits per second** pull-down menu to select **9600**.

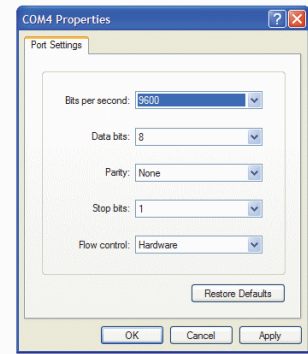

18. Transmit patient results from the VS2 patient archive. For instructions, see “[Transmitting Results](#)” on page 6-9.
19. Retransmit results from the VS2:
  - a. In the Home screen, touch the Recall icon.



- b. Touch **Last Rotor**.

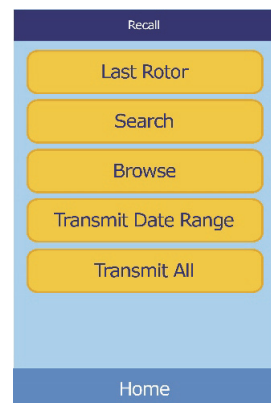

- c. The results from the last rotor are displayed.

Touch **Print**.

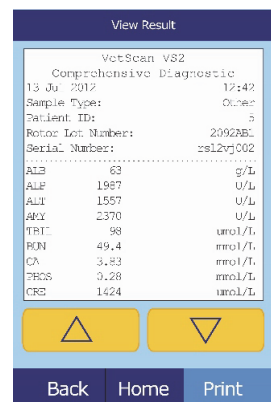



- d. Touch **Xmit**, and make sure **Print** is *not* selected.
- e. Touch **Results**.

The display shows Sending Report... while the results are transmitting.

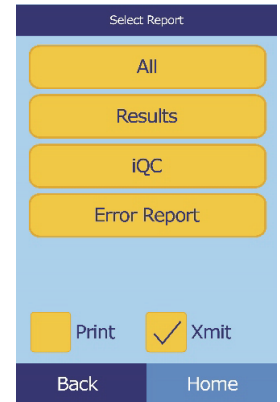

20. Check the HyperTerminal window to confirm that the results were transmitted.

If the results do not appear to have transmitted, contact Abaxis Technical Service 24 hours a day, 7 days week, at 1-800-822-2947.

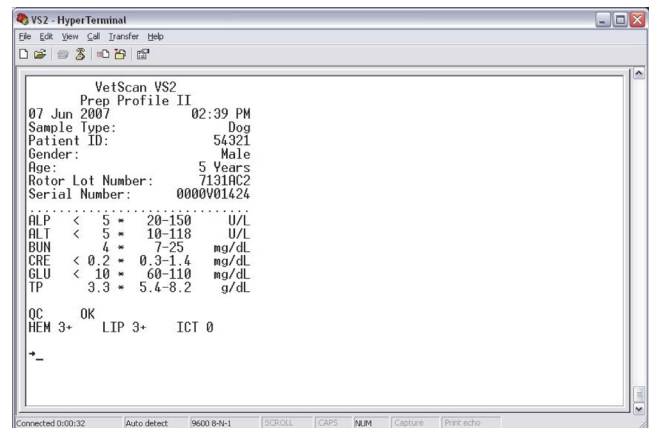

21. Close HyperTerminal. Click **Yes** to close the connection, then **No** to discard the connection settings.

## 11.4 Installing the Windows Vista Driver

Use this procedure to install the Abaxis driver that enables the analyzer to communicate with a PC running Windows Vista. The analyzer installs on the PC as a virtual communication port in Windows.

Installation requires the following:

- VetScan VS2 Analyzer
- PC with Windows Vista and a free USB port
- Type A/Type B USB cable
- Abaxis Driver CD (software files: P/N 110-5001)

**Note:** *Driver installation in Windows Vista requires a user account with administrative privileges.*

*The screenshots in these instructions are from a typical Vista installation. Some of these screens may vary slightly on your system.*

Install the driver as follows.

1. Insert the Abaxis Driver CD into the computer's CD drive.
2. The computer's default web browser then opens, displaying the VS2 driver installation guide links. Close the browser.
3. Go to **Start > My Computer** to display the computer's drives.
4. Right-click the CD drive icon, and select **Explore** from the pop-up menu.

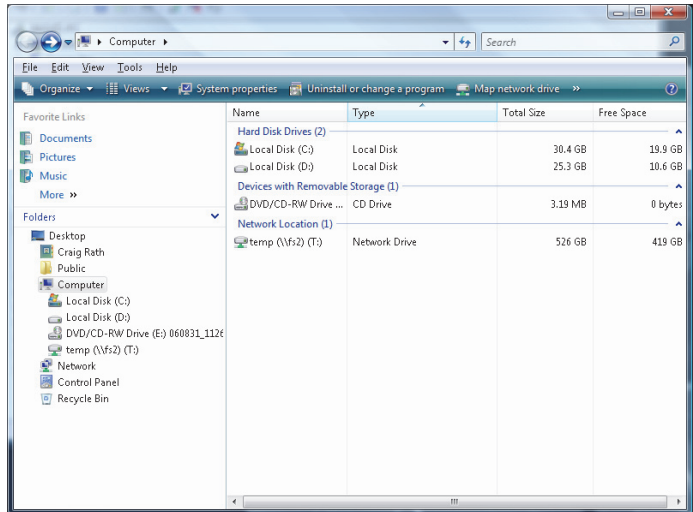

5. Open the **Win2K_XP** folder.

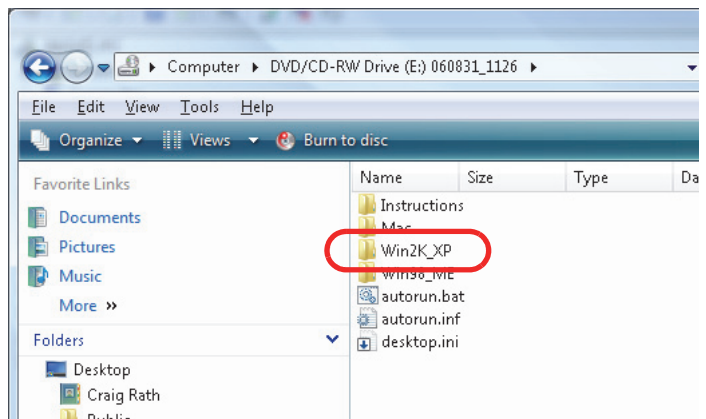

6. Double-click the file **Abaxis Driver Setup.exe**.

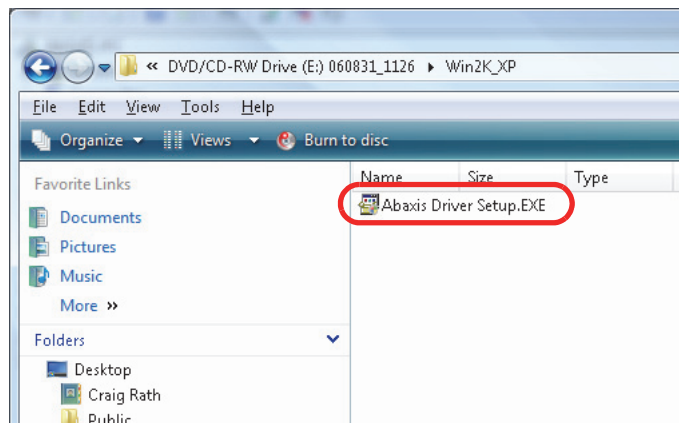

7. Installation then begins. When the installer finishes, click **OK**.

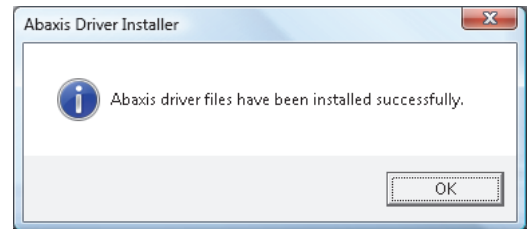

8. Use the USB cable to connect the VS2 to any available USB port on the computer.
9. Click **Start > Control Panel > Hardware and Sound > Device Manager**.
10. Click the **+** before **Ports (COM & LPT)**. Look for **Abaxis Blood Chemistry Analyzer**.

*Note: If the analyzer does not appear in the device list, do not reinstall the driver. Unplug the USB cable from the computer, then reinsert it. Check the device manager again.*

11. Note the port number to which the analyzer is assigned, and record this number. You will use this port number later in this procedure.

(In the example at right, the port is **COM4**.)

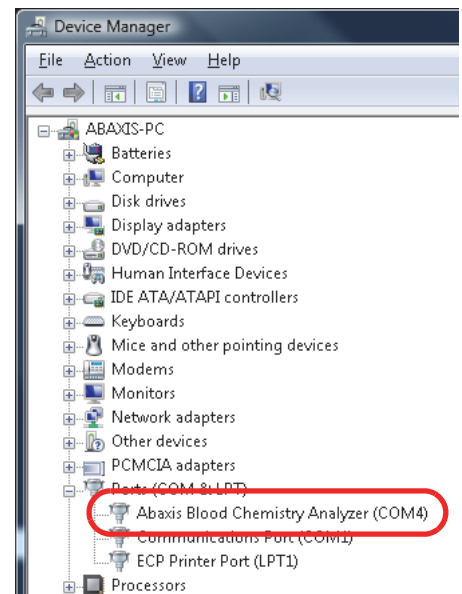

12. Close the Device Manager.

13. Transmit patient results from the VS2 patient archive. For instructions, see [“Transmitting Results”](#) on page 6-9.
14. Retransmit results from the VS2.
  - a. In the Home screen, touch the Recall icon.



b. Touch **Last Rotor**.

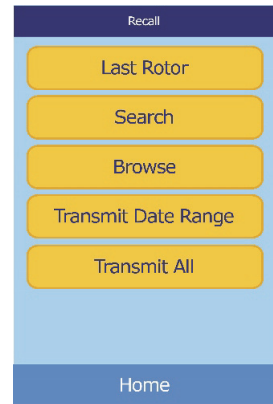

c. The results from the last rotor are displayed.

Touch **Print**.

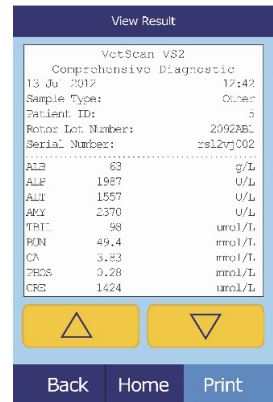

d. Select **Xmit**, and make sure **Print** is *not* selected.

e. Touch **Results**.

The display shows Sending Report... while the results are transmitting.

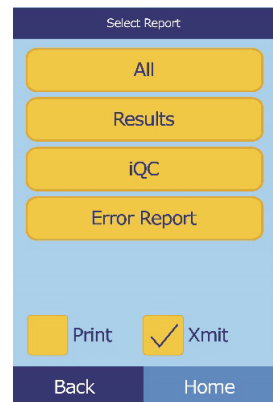

## 11.5 Installing the Mac OS X Driver

Use this procedure to install the Abaxis driver that enables the Abaxis analyzer to communicate with a Mac. The analyzer installs on the Mac as a virtual communication port in Mac OS X.

Installation requires the following:

- VetScan VS2 Analyzer
- Mac computer with Mac OS X and a USB port
- Type A/Type B USB cable
- Abaxis Driver CD (software files: P/N 110-5001)

*Note:* The screenshots in these instructions are from a typical Mac OS X installation. Some of these screens may vary in other versions of Mac OS X.

Install the driver as follows.

1. Turn on the Mac, and insert the Abaxis Driver CD into the Mac's CD-ROM drive.  
**Do not** connect the analyzer to the Mac yet.
2. Browse to the CD drive and run **FTDIUSBSerialDriver_vX_X_X.dmg** in the **Mac\Intel** folder for Intel-based Macs, or run **FTDIUSBSerialDriver_vX_X_X.dmg** in the **Mac\PPC** folder for PowerPC-based Macs.
3. Click **Continue**.

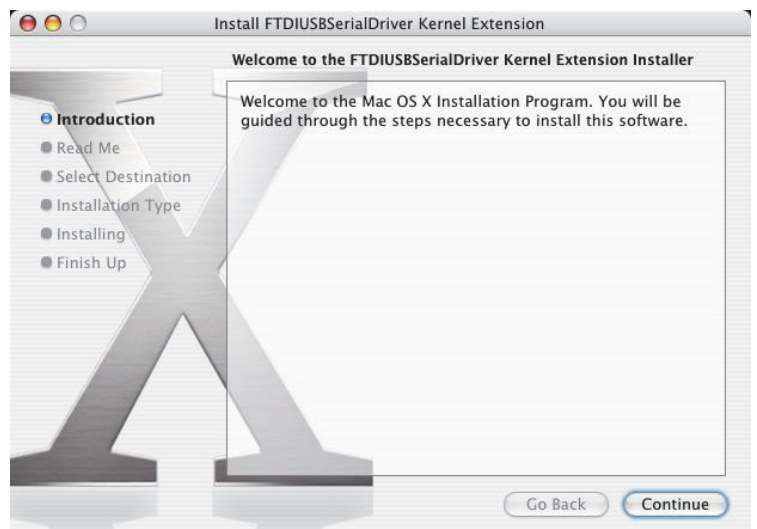

4. Click **Restart**.



5. Connect the USB cable to a Type A connector on the Mac and to the uppermost USB connector (Type B) on the back of the analyzer.
6. Turn on the analyzer.
7. Use the **Network** section in the **System Preferences** application (**Go > Applications > System Preferences > Network**) to enable the virtual communications port. Click **OK**.

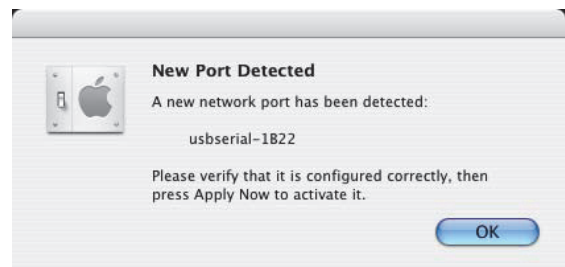

8. Select **Network Port Configurations** from the Show list.
9. Enable the new port (**usbserial-1B22** in the example at right) by checking its **On** box and clicking **Apply Now**.
10. Configure any needed applications to communicate with the analyzer over the virtual communication port.

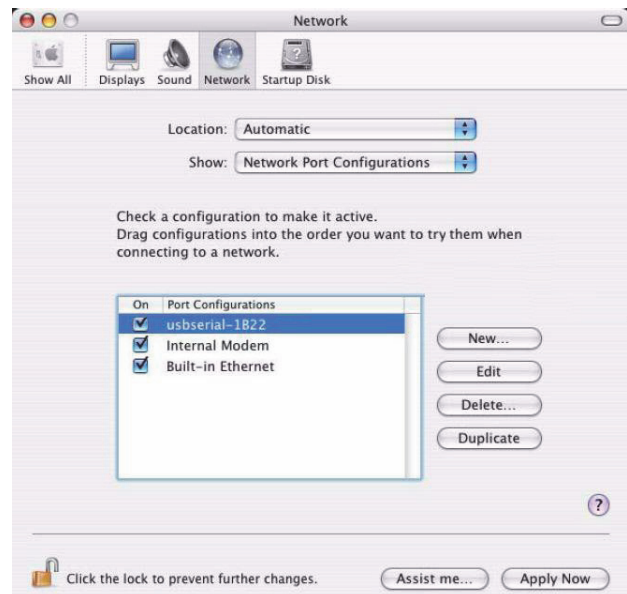

## 11.6 Installing the Linux Driver

Use this procedure to install the Abaxis driver that enables the Abaxis analyzer to communicate with a PC running Linux. The analyzer installs on the PC as a virtual communication port.

Installation requires the following:

- VetScan VS2 Analyzer
- PC with Linux (kernel version 2.4 and above) and a USB port
- Type A/Type B USB cable

***Note:** The driver is already included in the Linux OS (kernel version 2.4 and above).*

Enable the driver as follows.

1. Turn on the PC, and log in as “root.”
2. Connect the USB cable to a Type A connector on the PC and to the uppermost USB connector (Type B) on the back of the analyzer.
3. Turn on the analyzer.
4. Open a terminal window on the PC, and enter the command **modprobe ftdi_sio** to enable the driver.
5. Configure any PC applications (e.g. minicom) to communicate with the analyzer over the virtual communication port (e.g. /dev/ttyS0).

## 11.7 Using HyperTerminal

This section describes how to set up and use Windows' HyperTerminal to capture and transmit test results.

**Note:** *The screen captures and menu configurations shown here may vary depending on your version of Windows.*

### 11.7.1 Setting Up HyperTerminal

1. On the Windows desktop, click **Start > Programs > Accessories > Communications > HyperTerminal** to view the HyperTerminal Folder. Click **HyperTrm.exe** to start the HyperTerminal setup wizard.

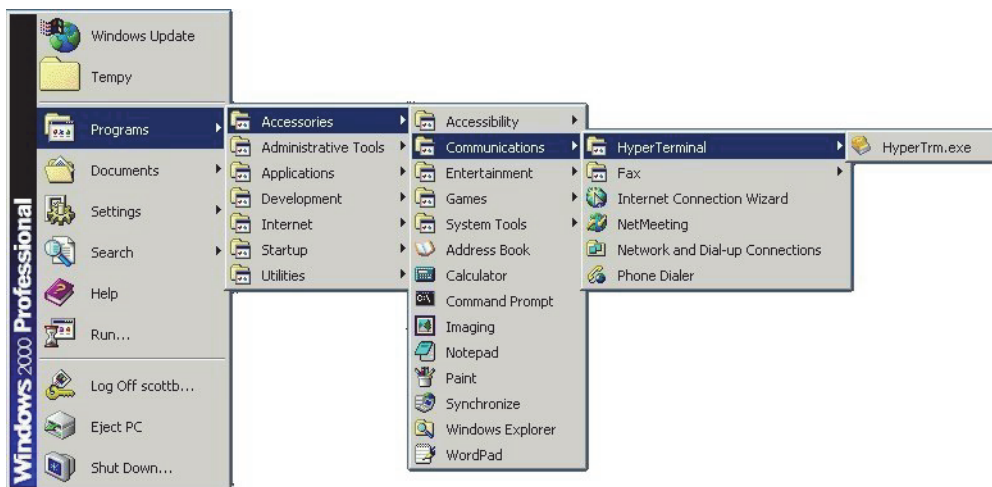

If HyperTerminal does not appear, install it by going to **Start > Settings > Control Panel > Add/Remove Programs (Add/Remove Windows Components > Communications tab)**. Consult Windows help for details.

2. Type a descriptive name (such as Abaxis) for the connection in the **Name** box. Click **OK**.

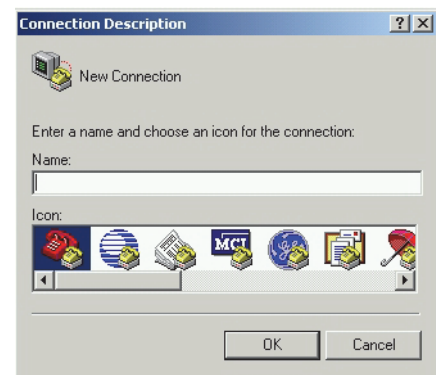



3. In the **Connect Using** dialog, select the port that the analyzer is connected to, then click **OK**. (The other settings are not required.)

**Note:** *If the port is unknown, select any one for now. If needed, you can run the wizard again to try other ports.*



4. Change **Bits per second** to **9600**, then click **OK**. Leave all other settings at their defaults.

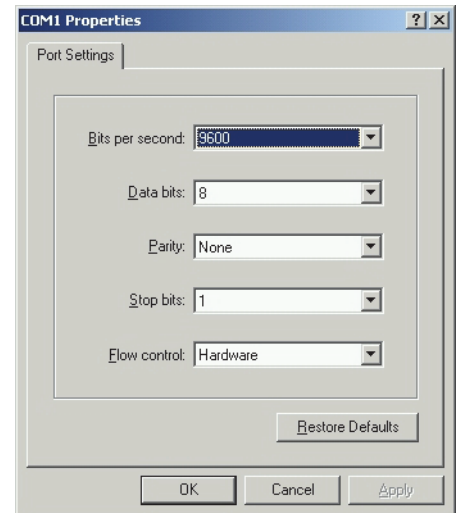

5. If a valid port was selected, a new HyperTerminal session starts. The status pane on the lower, left corner of the window should display “Connected” as shown.

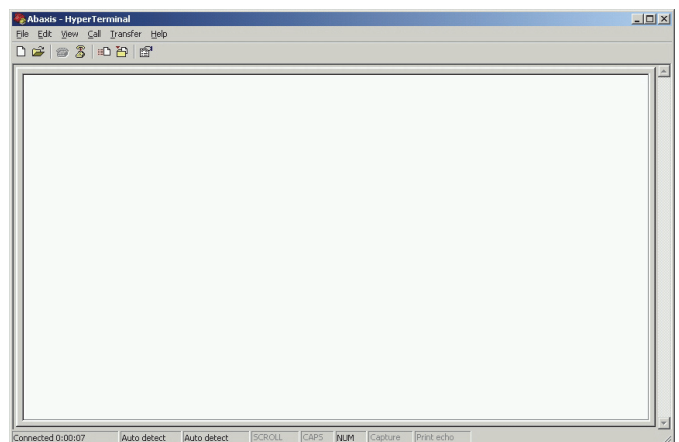

**Note:** *If an error message appears, close HyperTerminal (do not save changes). Start the HyperTerminal setup wizard again, and choose a different port.*

6. Click **File > Save As** on the menu to save the HyperTerminal session. Note where the session file is saved so that it can be loaded in the future (create a shortcut on the desktop if necessary). Proceed to the next section for instructions on capturing results.

## 11.7.2 Capturing and Transmitting Results

1. Prepare HyperTerminal to capture results by loading a saved session file or by creating a new session file as described in [Section 11.7](#).
2. Click **Transfer > Capture Text** on the menu. Select a path and file name and click **Start**.

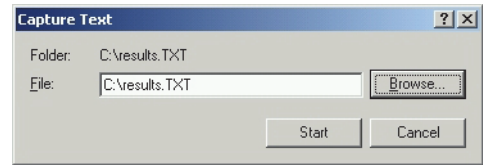

Any results transmitted to the computer from this point forward will be captured in the designated text file.

3. Transmit results to the computer following the instructions in [Section 5](#) and [Section 6](#). The results will appear in the HyperTerminal window, as shown in this example. In addition, the results can be manually copied and pasted into other applications by highlighting the results and using the **Edit** menu.

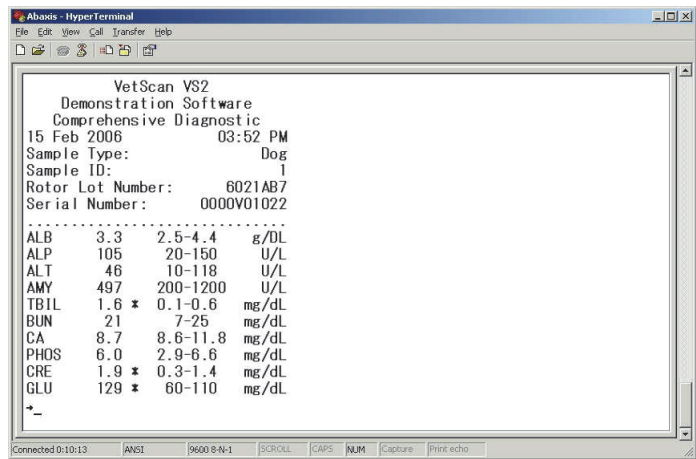

**Note:** *If the results do not appear in the HyperTerminal window, an incorrect port may have been selected in setup ([Section 11.7](#)). Repeat the setup and select a different port.*

4. After the results are transmitted, select **Transfer > Capture Text > Stop** in the menu. The captured text file can be used by most word processing, spreadsheet, and database applications.
5. Close HyperTerminal by selecting **File > Exit** in the menu.

# Ordering Information

## 12.1 Required Materials

This section lists the materials needed to operate the VetScan VS2 according to recommended procedures — see “[Test Procedure and Results](#)” on page 4-1.

## 12.2 Ordering Information

To order reagent rotors, pipettes, tips, printer paper, or other VetScan supplies or accessories, contact your authorized distributor, or contact Abaxis Customer Service at 1-800-822-2947 during regular business hours.

You can get the latest information online at this address:

**[www.order.abaxis.com](http://www.order.abaxis.com)**

**Note:** *All Abaxis catalog numbers are subject to change without notice. You can verify the correct numbers by calling Abaxis Customer Service during regular business hours at 1-800-822-2947.*

## 12.3 VetScan Reagent Rotors

<b>Reagent Rotor Package</b>	<b>Catalog Number</b>
Canine Wellness Profile	Abaxis # 500-0044
Comprehensive Diagnostic Profile	Abaxis # 500-0038
Prep Profile II	Abaxis # 500-0026
Critical Care Plus	Abaxis # 500-0042
T ₄ /Cholesterol Profile	Abaxis # 500-0037
Kidney Profile Plus	Abaxis # 500-0045
Mammalian Liver Profile	Abaxis # 500-0040
Equine Profile Plus	Abaxis # 500-0043
Avian/Reptilian Profile Plus	Abaxis # 500-0041
Large Animal Profile	Abaxis # 500-0023

**Note:** See “*Methods Performance*” on page C-1 for information about individual tests and methods.

## 12.4 Optional Materials

<b>Operational Materials</b>	<b>Catalog Number</b>
Tip, Disposable, rack of 96	Abaxis # 500-9007
Mini Pipette, 100 µL, Gray	Abaxis # 500-9006
Instrument Carrying Case with Wheels	Abaxis # 100-9001
Internal Printer Paper Roll	Abaxis # 1100-4410

## iQC Codes

### A.1 Using iQC Codes for Troubleshooting

The analyzer can display warnings, iQC codes, and messages to help diagnose and resolve potential problems.

iQC (Intelligent Quality Control) is a series of automatic checks that verify the chemistry, optics, and electronic functions of the analyzer during each run. This ensures that operators in a wide range of environments report only accurate and reliable results. iQC automatically suppresses a single chemistry — or the entire panel — if it detects uncharacteristic performance, and immediately alerts the operator to any problems.

If the analyzer displays an iQC code, find the code in the following pages, and try the suggested solutions *in the order presented*.

**Note:** *If the iQC code is not listed or if you cannot correct a particular problem, record the iQC number or print the report, and contact Abaxis Technical Support, 24 hours a day, 7 days a week, at 1-800-822-2947, or send a fax to 1-877-900-9333.*

<b>iQC Code</b>	<b>iQC Message</b>	<b>Solution</b>
<b>403A</b>	Bead Missing Error	Analyzer did not detect all rotor chemistry beads. Rerun with new rotor.
<b>403B</b>	Distribution Error	Reagent beads did not dissolve properly. Rerun with new rotor.
<b>403C</b>	Photometer Error	Possibly triggered by lipemic sample. Spin and check sample integrity. Contact Abaxis Technical Support or verify integrity before rerun.
<b>403D</b>	Sample Mix Error	Sample did not mix with reagents sufficiently. If patient HCT > 60%, rerun with plasma or serum.
<b>403E</b>	Dilution Error	Insufficient rotor reagents to complete run. Rerun with new rotor.
<b>4031</b>	Photometer Error	Analyzer's photometer detected brighter than normal flash. If symptom persists, contact Abaxis Technical Support.
<b>4037</b>	Insufficient Sample	The rotor has not received enough sample to function properly. If patient HCT >60%, rerun with plasma or serum.
<b>4038</b>	Sample Distribution Error	Sample did not reach chemistries. Rerun with new rotor.
<b>4039</b>	Diluent Absorbance Error	Background absorbance too high. Contact Abaxis Technical Support.
<b>404D</b>	Flash Lamp Noise Error	During one of the system checks, the analyzer attempted to compute an absorbance from a cluster of flashes that were too variable. Possibly triggered by lipemic sample. Spin and check sample integrity. Contact Abaxis Technical Support or verify integrity before rerun.
<b>404F</b>	Temperature Error	Rotor temperature too variable or outside proper range during run. If symptom persists, contact Abaxis Technical Support.
<p><b>Note:</b> If the iQC code is not listed or if you cannot correct a particular problem, record the iQC number or print the report, and contact Abaxis Technical Support, 24 hours a day, 7 days a week, at 1-800-822-2947, or send a fax to 1-877-900-9333.</p>		

<b>iQC Code</b>	<b>iQC Message</b>	<b>Solution</b>
<b>4042</b>	Temperature Error	Temperature deviated more than one degree during run. Accuracy of certain chemistries may be affected. Rerun with new rotor.
<b>4044</b>	iQC Bead Mix Error	Analyzer cannot determine exposure status if iQC beads do not mix correctly. Possibly triggered by lipemic sample. Spin and check sample integrity. Contact Abaxis Technical Support or verify integrity before rerun.
<b>4045</b>	RQC Error	Reagent QC beads recovered below limit. Rotor may have been stored incorrectly. Rerun with new rotor.
<b>4051</b>	Flash Lamp Level Error	Analyzer checked lamp (to make sure it flashes when optical cuvette is sampled) but detectors did not recognize lamp flashes. If symptom persists, contact Abaxis Technical Support.
<b>4053</b>	Engine Reset Error	Analyzer component restarted unexpectedly. Contact Abaxis Technical Support.
<b>4069</b>	Sample Quality Error	Sample may contain physical interferents. Confirm sample integrity and rerun rotor.
<b>410D</b> <b>410E</b>	Bar Code Format Error	Analyzer could not read rotor's bar code. If symptom persists, contact Abaxis Technical Support.
<b>410F</b> <b>4110</b> <b>4111</b>	Bar Code Format Error	Analyzer did not recognize rotor. Contact Abaxis Technical Support.
<b>4220</b>	Drawer Open Jam	Drawer cannot open correctly. Remove any obstructions. If symptom persists, contact Abaxis Technical Support.
<b>4221</b>	Drawer Closed Jam	Drawer cannot close correctly. Remove any obstructions. If symptom persists, contact Abaxis Technical Support.
<b>Note:</b> If the iQC code is not listed or if you cannot correct a particular problem, record the iQC number or print the report, and contact Abaxis Technical Support, 24 hours a day, 7 days a week, at 1-800-822-2947, or send a fax to 1-877-900-9333.		

<b>iQC Code</b>	<b>iQC Message</b>	<b>Solution</b>
<b>4222</b>	CAM Up Jam	Analyzer may need service. Contact Abaxis Technical Support.
<b>4223</b>	CAM Down Jam	Analyzer may need service. Contact Abaxis Technical Support.
<b>430B</b>	Spindle Motor Error	Spindle motor not turning properly. Contact Abaxis Technical Support.
<p><b>Note:</b> If the iQC code is not listed or if you cannot correct a particular problem, record the iQC number or print the report, and contact Abaxis Technical Support, 24 hours a day, 7 days a week, at 1-800-822-2947, or send a fax to 1-877-900-9333.</p>		



## Supported Printers

### **B.1 Printers Supported by the VetScan VS2**

The VetScan VS2 is compatible with most Hewlett-Packard (HP) PCL3-compatible USB printers. Abaxis has tested a limited number of these printers and validated their use with the VetScan VS2.

The following VS2 printers are validated as of October 2012.

- HP Deskjet 6940
- HP Officejet 6000
- HP Officejet 6100
- HP Officejet 100 mobile
- HP Envy 110

***Note:** Printer capabilities are subject to change without notice.*

*For an up-to-date list of printers supported by the VetScan VS2, contact Abaxis Technical Support 24 hours a day, 7 days a week, at 1-800-822-2947.*



# Methods Performance

This appendix lists the materials required for operating the VetScan VS2, and the test panels provided by each profile rotor.

## C.1 Materials Required

The following materials are required to operate the VetScan VS2 according to the recommended procedure given in “[Test Procedure Summary](#)” on page 4-14.

Materials	Catalog Number
<b><i>Provided with Purchase of Reagent Rotor Profiles</i></b>	
■ VetScan Reagent Profile	See “ <a href="#">Ordering Information</a> ” on page 12-1.
<b><i>Optional</i></b>	
■ 100 µL Pipette	
■ Tips, disposable	Distributor
■ Transfer pipettes (to dispense samples) (1.5 mL extended fine tip, small bulb recommended)	
■ Compressed air, can	Computer store

## C.2 Rotor Test Panels

The following chart shows the test panels provided by each profile rotor.

Profile	ALB	ALP	ALT	AMY	AST	BA	BUN	Ca	CHOL	CHW	CK	Cl-	CRE	GGT	GLOB	GLU	K+	Mg	Na+	PHOS	T ₄	TBIL	tCO ₂	TP	UA
Canine Wellness Profile	✓	✓	✓				✓	✓		✓			✓		✓	✓				✓		✓		✓	
Comprehensive Diagnostic Profile	✓	✓	✓	✓			✓	✓					✓		✓	✓	✓		✓	✓		✓		✓	
Prep Profile II		✓	✓				✓						✓			✓								✓	
Critical Care Plus			✓				✓					✓	✓			✓	✓		✓				✓		
T4-Cholesterol Profile									✓												✓				
Kidney Profile Plus	✓						✓	✓					✓	✓		✓	✓		✓				✓		
Mammalian Liver Profile	✓	✓	✓			✓	✓		✓					✓								✓			
Equine Profile Plus	✓				✓		✓	✓			✓		✓	✓	✓	✓	✓		✓			✓	✓	✓	
Avian/Reptilian Profile Plus	✓				✓	✓		✓			✓				✓	✓	✓		✓	✓				✓	✓
Large Animal Profile	✓	✓			✓		✓	✓			✓			✓	✓	✓		✓		✓				✓	

**Note:** VetScan rotor rotational frequency: 5500 RPM

**To Order VetScan VS2 Analyzer Profile Rotors:**

- For profile information and product numbers, go to [http://www.abaxis.com/veterinary/vetscan_vs2_profiles.html](http://www.abaxis.com/veterinary/vetscan_vs2_profiles.html)
- Contact an authorized distributor, or Abaxis Customer Service at 1-800-822-2947, during regular business hours.

### C.3 Warnings and Precautions

- The diluent container in the reagent rotor is automatically opened when the analyzer drawer closes. A rotor with an opened diluent container cannot be re-used. Ensure that the sample or control has been placed into the rotor before closing the drawer.
- The reagent rotors are plastic and can crack or chip if dropped. Never use a dropped rotor, as it may spray biohazardous material throughout the interior of the analyzer.
- Reagent beads may contain acids or caustic substances. The operator does not come into contact with the reagent beads when following the recommended procedures. If the beads are handled (such as when cleaning up after dropping and cracking a reagent rotor), avoid touching (with skin), ingesting, or inhaling the reagent beads.
- Reagent beads and diluent contain sodium azide, which can react with lead and copper plumbing to form highly explosive metal azides. Reagents do not come into contact with lead and copper plumbing when following recommended procedures. However, if the reagents do come into contact with such plumbing, flush with a large volume of water to prevent azide buildup.
- Calcium reagent beads contain arsenazo III sodium, a possible carcinogen. The operator does not come into contact with the reagent beads when following the recommended procedures. If the operator does come into contact with the beads, immediately flush eyes or skin with copious amounts of water for 15 minutes. If inhaled, remove to fresh air. If swallowed, wash out mouth with water. Call a physician.

### C.4 Storage

Store reagent rotors in their sealed pouches at 2–8 °C (36–46 °F). To use reagent rotors, remove the rotors in their sealed foil pouches from the refrigerator. Open the pouch, and remove the rotor just prior to running the test.

Make sure rotors do not remain at room temperature for more than a total of 48 hours. Open the pouch and remove the rotor just before running the test.

Do not expose rotors, in or out of the foil pouches, to direct sunlight or to temperatures above 32 °C (90 °F). Rotors must be used within 20 minutes of opening the pouches. Rotors in opened pouches cannot be returned to the refrigerator for later use.

### C.5 Indications of Reagent Rotor Instability or Deterioration

- When stored as described above, all reagents contained in the reagent rotor are stable until the expiration date printed on the rotor pouch. Do **not** use a rotor after the expiration date. The expiration date is also encoded in the bar code printed on the bar code ring. The analyzer displays an error if the reagents have expired.
- A torn or otherwise damaged pouch may allow moisture to reach the unused rotor and adversely affect reagent performance. Do not use a rotor from a damaged pouch.

### C.6 Sample Collection and Preparation

- The minimum required sample size is ~90 µL of heparinized whole blood, heparinized plasma, serum, or serum control. The reagent rotor sample chamber can contain up to 120 µL of sample.
- Fill specimen collection tubes at least halfway to prevent an excessive concentration of anti-coagulant in the patient sample.
- Samples collected in a heparinized micropipette should be dispensed into the reagent rotor **immediately** following collection.
- Use only lithium heparin (green top) evacuated specimen collection tubes for whole blood or plasma samples. Use no-additive (red top) evacuated specimen collection tubes or serum separator tubes (red or red/black top) for serum samples.
- Whole blood samples obtained by venipuncture must be homogeneous before transferring a sample to the reagent rotor. Gently invert the collection tube several times just before sample transfer. Do **not** shake the collection tube, or hemolysis can result.
- The test must be begun **within 10 minutes** of transferring the sample into the reagent rotor.
- Whole blood venipuncture samples should be run within 60 minutes of collection¹. **Glucose** concentrations decrease approximately 5–12 mg/dL in 1 hour in uncentrifuged samples stored at room temperature². **AST** samples may be artificially high due to in-vitro hemolysis in stored whole blood³. The sample can be separated into plasma or serum and stored in capped

1. National Committee for Clinical Laboratory Standards (NCCLS). 1984. Procedures for the Handling and Processing of Blood Specimens; Tentative Standard. NCCLS document H18-T. Villanova, PA: NCCLS; p. 219.

2. Overfield, CV, J Savory, and MG Heintges. 1972. Glycolysis: a re-evaluation of the effect on blood glucose. Clin Chim Acta 39: 35-40.

sample tubes at 2–8 °C (36–46 °F) if the sample cannot be run within 60 minutes.

- **Total protein** and **albumin** results from hay-eating horses may be altered if the sample has been taken within a few hours of the last meal⁴.
- **Total bilirubin** results can be adversely affected by photodegradation⁵. Whole blood samples not run immediately should be stored in the dark for no longer than 60 minutes. If the sample cannot be analyzed within that period, it should be separated into plasma or serum and stored in a capped sample tube in the dark at low temperatures⁶.
- **Glucose** concentrations are affected by the length of time since the patient has last eaten and by the type of sample collected from the patient. To accurately interpret glucose results, samples should be obtained from a patient who has been fasting for at least 12 hours. Glucose concentrations in plasma and serum are typically higher than glucose levels in whole blood⁴.

### C.7 Known Interfering Substances

- Physical interferents (hemolysis, icterus, and lipemia) can change the reported concentrations of some analytes. The sample indices are printed in the results to inform the operator of the levels of interferents in each sample. If the presence of one or more interferents causes a significant change in the concentration of a particular analyte, that result is suppressed. See “[Troubleshooting](#)” on page 8-1 for an explanation of sample indices and suppressed results.
- Amylase activity can be elevated by contamination of the sample with human salivary amylase. Salivary amylase is found in human saliva, sweat glands, and lungs⁷.
- Potassium levels are affected by the presence of high levels of platelets (> 1,000,000/μL) or white blood cells (> 200,000/μL). Potassium can be released from

these blood constituents when the blood is allowed to clot. This effect may also be observed when abnormal cells are present⁸.

- Potassium levels in canines, felines, and equines can be artificially increased by potassium released from platelets during clotting^{3,9}. Normal canine and feline red blood cells do not contain significant levels of potassium, with the exception of the Akita breed⁹. Potassium levels in equines are artificially increased by hemolysis.
- Sodium results in canines, felines, and equines may be artificially depressed due to hyperlipidemia or severe hyperproteinemia^{3,9}.

### C.8 Test Parameters

The VetScan VS2 Chemistry Analyzer operates at ambient temperatures between 15–32 °C (59–90 °F). Analysis time for all VetScan Rotors is <15 minutes. The analyzer maintains the reagent rotor at a temperature of 37 °C (98.6 °F) over the measurement interval.

### C.9 Test Procedure

Note: Complete step-by-step operating procedures are given in [Section 4.4](#).

1. Remove a reagent rotor from the refrigerator. (The rotor can be used directly from the refrigerator. There is no need to warm up the rotor.)
2. Collect the specimen.
3. Remove the reagent rotor from its pouch. Expel any air or air bubbles from the tip of the sample transfer device before dispensing 90–120 μL of sample or control into the rotor through the sample port. A 90 μL sample forms a line between the two arrows etched on the rotor. If there are air bubbles in the chamber, add more sample (up to a total of 120 μL).

**WARNING: Do not tap the rotor on the table or work bench to empty the sample port, as this can damage the rotor.**

4. Touch **Open** to open the drawer. Place the rotor in the round cavity in the drawer and touch **Close**. There is no need to orient the rotor in a particular

- 
3. Carlson, GP. 1996. Clinical chemistry tests. In: B P Smith, ed., Large Animal Internal Medicine, 2nd ed. St. Louis: Mosby-year Book, Inc. pp. 441–469.
  4. Coles, EH. 1986. Veterinary Clinical Pathology, 4th ed. Philadelphia: W.B. Saunders Company; p. 153.
  5. Sherwin, JE and R Obernolte. 1989. Bilirubin. In: LA Kaplan and AJ Pesce, eds., Clinical Chemistry: Theory, Analysis, and Correlation, 2nd ed. St. Louis: The C.V. Mosby Company; pp. 1009–1015.
  6. Henry, RJ, DC Cannon, and JW Winkelman. 1974. Clinical Chemistry: Principles and Techniques, 2nd ed. New York: Harper and Row; pp. 417–421; 1058–1059.
  7. Yuan, SK and FJ Liu. 1991. Laboratory diagnosis of gastrointestinal tract and exocrine pancreatic disorders. In: JB Henry, Clinical Diagnosis and Management by Laboratory Methods, 18th ed. Philadelphia: W.B. Saunders Company; p. 527.

- 
8. Willard, xx. 1989. Electrolyte and acid-base abnormalities. In: xx Willard, H Tvedten, and GH Turnwald, eds., Small Animal Clinical Diagnosis by Laboratory Methods. Philadelphia: W.B. Saunders Company; pp. 103–120.
  9. DiBartola, SP, RA Green, and HS Autran de Morais. 1994. Electrolytes and acid-base. In: xx Willard, H Tvedten, and GH Turnwald, eds., Small Animal Clinical Diagnosis by Laboratory Methods, 2nd ed. Philadelphia: W.B. Saunders Company; pp. 97–106.

direction in the drawer. The analysis begins when the drawer closes.

5. Input patient and operator identification numbers as directed by the messages on the analyzer display. The analyzer processes the sample with no further input from the operator. The entire analysis takes < 15 minutes and is complete when an Analysis complete message appears on the display.
6. The results are stored in the analyzer. Print the results, transmit to a computer, or touch **Open** to bypass this step. To transmit, see “[Connecting to an External Computer](#)” on page 11-1.
7. The drawer automatically opens. Remove the rotor from the drawer and follow standard hazardous waste disposal procedures when disposing the rotor. The rotor may be placed back into the pouch before disposal. Touch **Close** if another reagent rotor is not to be run immediately.

### C.10 Timing Considerations

- Analyze whole blood samples collected by venipuncture within 60 minutes of collection.
- Run the reagent rotor within 10 minutes of applying sample or control to the rotor.
- Dispense samples collected in micropipettes into the rotor immediately after collection.

### C.11 Quality Control

Although elaborate quality controls are integrated into the VetScan VS2 Chemistry Analyzer and reagent profile rotors, the analyzer’s performance can also be verified by running external controls. This can be accomplished by testing an aliquoted sample with known values, or by using a serum-based, commercially available control. See “[Running Controls](#)” on page 7-3.

### C.12 Calibration

The VetScan VS2 Chemistry Analyzer is calibrated by the manufacturer before shipment. The bar code printed on the bar code ring provides the analyzer with rotor-specific calibration data. See “[Calibration and Quality Control](#)” on page 7-1.

### C.13 Results

The VetScan VS2 Chemistry Analyzer automatically calculates and prints the analyte concentrations in the sample. Details of the endpoint and rate reaction calculations are found in “[Principles of Procedure and Operation](#)” on page 9-1.

The VetScan analyzer calculates the globulin concentration using the total protein and albumin concentrations determined by the chemical analyses. If the total protein or albumin results are out of range or suppressed, the globulin concentration cannot be reliably calculated and is not reported.

### C.14 Messages Printed in Results

- Results outside the reference range are indicated in the results by an asterisk ( * ) next to the analyte concentration.
- Results outside the dynamic range are indicated in the results by a greater-than symbol ( > ) next to the highest value of the dynamic range, or a less-than symbol ( < ) next to the lowest value of the dynamic range. (For example, concentrations outside an analyte dynamic range are printed as > 700 or < 10, respectively.)
- “HEM”, “LIP”, or “ICT” is printed in place of the analyte concentration if hemolysis (HEM), lipemia (LIP), or icterus (ICT) adversely affects the results for that analyte. LIP is also printed if both lipemia and icterus affect a result. HEM is also printed if hemolysis and icterus, hemolysis and lipemia, or hemolysis, lipemia, and icterus affect a particular analyte. Examine the sample indices to determine if more than one interferent is affecting a particular result.
- The sample indices are printed in the results. The indices indicate the degree of hemolysis, icterus, and lipemia in the sample, measured on a scale of 0 (clear), 1+ (slight), 2+ (moderate), and 3+ (gross).

### C.15 Limitations of Procedure

- Lithium heparin is the only anticoagulant recommended for use with the VetScan VS2 Chemistry Analyzer.
- If a result for a particular test exceeds the assay range, the sample may be able to be diluted (see “[Troubleshooting](#)” on page 8-1). If the sample again appears out of range, have it analyzed by another approved test method or sent to a referral laboratory. Do **not** dilute the sample and run it a third time.
- If sample or reagent rotor errors are indicated on the analyzer display or printed in the results, consult “[Troubleshooting](#)” on page 8-1 for an explanation of the error message.
- Samples with high HCT do not reprint as hemolyzed. Typically report cancellation code.



## C.16 Expected Values

These reference ranges are provided as a guideline. The most definitive reference ranges are those established for the patient population. Test results should be interpreted in conjunction with the patient's clinical signs. Potassium and total protein levels determined in plasma may differ from the ranges given below.

**Table C-1: Canine, Feline, Equine and Bovine Ranges**

Analyte	Canine	Feline	Equine	Bovine
<b>Alanine aminotransferase (ALT)</b>	10–118 U/L	20–100 U/L	5–20 U/L	N/A
<b>Albumin (ALB)</b>	2.5–4.4 g/dL* (25–44 g/L)	2.2–4.4 g/dL* (27–45 g/L)	2.2–3.7 g/dL (22–37 g/L)	2.5–3.8 g/dL (25–38 g/L)
<b>Alkaline phosphatase (ALP)</b>	20–150 U/L	10–90 U/L	50–170 U/L	23–135 U/L
<b>Amylase (AMY)</b>	200–1200 U/L*	300–1100 U/L*	5–15 (U/L)	N/A
<b>Aspartate aminotransferase (AST)</b>	14–45 U/L	12–43 U/L	175–340 U/L	66–211 U/L
<b>Bile Acids (BA)</b>	Fasting: 1–4 µmol/L (1–4 µmol/L). 2 Hrs Postprandial: 2–15 µmol/L (2–15 µmol/L). Cutoff: 25 µmol/L (25 µmol/L)**.	Fasting: 1–3 µmol/L (1–3 µmol/L). 2 Hrs Postprandial: 7–9 µmol/L (7–9 µmol/L). Cutoff: 25 µmol/L (25 µmol/L)**.	Fasting: NA. Postprandial: NA. Cutoff: 25 µmol/L (25 µmol/L)**.	
<b>Blood Urea Nitrogen (BUN)</b>	7–25 mg/dL* (2.5–8.9 mmol urea/L)	10–30 mg/dL (3.6–10.7 mmol urea/L)	7–25 U/L (2.5–8.9 mmol urea/L)	6–20 mg/dL (2.14–7.14 mmol urea/L)
<b>Calcium (Ca)</b>	8.6–11.8 mg/dL* (2.15–2.95 mmol/L)	8.0–11.8 mg/dL* (2.00–2.95 mmol/L)	11.5–14.2 mg/dL (2.8–3.55 mmol/L)	7.9–9.6 mg/dL (1.97–2.39 mmol/L)
<b>Chloride (Cl-)</b>	106–120 mmol /L	112–126 mmol /L***	92–104 mmol /L	N/A
<b>Cholesterol (CHOL)</b>	125–270 mg/dL (3.2–7.0 mmol/L)	90–205 mg/dL (2.3–5.3 mmol/L)	50–140 mg/dL (1.3–3.6 mmol/L)	N/A
<b>Creatine Kinase (CK)</b>	20–200 U/L	50–450 U/L	120–470 U/L	83–688 U/L
<b>Creatinine (CRE)</b>	0.3–1.4 mg/dL† (27–124 µmol/L)	0.3–2.1 mg/dL* (27–186 µmol/L)	0.6–2.2 mg/dL (35–150 µmol/L)	N/A
<b>GGT</b>	0–7.0 U/L	0–2.0 U/L	5–24 U/L	12–48 U/L
<b>Globulin (GLOB)††</b>	2.3–5.2 g/dL (23–52 g/L)	1.5–5.7 g/dL (15–57 g/L)	2.7–5.0 g/dL (27–50 g/L)	4.0–5.5 g/dL (40–55 g/L)
<b>Glucose (GLU)</b>	60–110 mg/dL (3.3–6.1 mmol/L)	70–150 mg/dL (3.9–8.3 mmol/L)	65–110 mg/dL (3.6–6.1 mmol/L)	N/A
<b>Magnesium (Mg)</b>	1.8–2.4 mg/dl (0.74–0.99 mmol/L)	2.0–2.5 mg/dL (0.82–1.03 mmol/L)	1.7–2.9 mg/dL (0.70–1.19 mmol/L)	1.7–2.9 mg/dL (0.70–1.19 mmol/L)
<b>Phosphorus (PHOS)</b>	2.9–6.6 mg/dL (0.94–2.13 mmol/L)	3.4–8.5 mg/dL (1.10–2.74 mmol/L)	1.9–4.3 mg/dL (0.61–1.39 mmol/L)	4.1–9.2 mg/dL (1.32–2.97 mmol/L)
<b>Potassium (K+)</b>	3.7–5.8 mmol/L	3.7–5.8 mmol/L	2.5–5.2 mmol/L	N/A
<b>Sodium (Na+)</b>	138–160 mmol/L	142–164 mmol/L	126–146 mmol/L	N/A
<b>Thyroxine (T₄)</b>	1.1–4.0 g/dL (14–52 nmol/L)	1.5–4.8 µg/dL (19–62 nmol/L)	1.0–2.8 g/dL (13–36 nmol/L)	N/A
<b>Total Bilirubin (TBIL)</b>	0.1–0.6 mg/dL (2–10 µmol/L)	0.1–0.6 mg/dL (2–10 µmol/L)	0.5–2.3 mg/dL (8.6–39.3 µmol/L)	N/A
<b>Total Carbon Dioxide (tCO₂)</b>	12–27 mmol/L	15–24 mmol/L	20–33 mmol/L	N/A
<b>Total Protein (TP)</b>	5.4–8.2 g/dL* (54–82 g/L)	5.4–8.2 g/dL* (54–82 g/L)	5.7–8.0 g/dL (57–80 g/L)	6.6–9.3 g/dL (66–93 g/L)
<b>Uric Acid (UA)</b>	1.0–9.0 mg/dL (60–536 µmol/L)	1.0–9.0 mg/dL (60–536 µmol/L)	1.0–9.0 mg/dL (60–536 µmol/L)	N/A

* Ranges cited by Meyer, et al¹⁰ for dogs and cats were adjusted to reflect field data collected by Abaxis on the VetScan VS2 Chemistry Analyzer.

** Cutoffs for Bile Acids (BA) set for 100% specificity with a sensitivity of 74% for dogs and cats. See Ettinger SJ, Feldman EC, eds. St. Louis: W.B. Saunders Company. 2000: 1288–1290.

*** Feline reference interval is for adults only. Kittens (younger than 6 months) may have lower chloride levels.

† Creatinine values were lowered 0.2 mg/dL from those in Meyer, et al¹⁰. The Jaffé method measures creatinine, and “quasi-creatinine” compounds not measured in the enzymatic method used in the VetScan Diagnostic Profile Plus.

†† Calculated value.

10. Jacobs, DS, BL Kasten, Jr., WR De Mott, and WL Wolfson. 1990. Laboratory Test Handbook, 2nd ed. Baltimore: Williams & Wilkins; pp. 302–303.

## C.17 Performance Characteristics

### Linearity

The chemistry for each analyte is linear over the dynamic range listed in Table 2 when the VetScan VS2 Analyzer is operated according to the recommended procedure (see “Test Procedure and Results” on page 4-1).

**Table C-2: VetScan VS2 Dynamic Ranges**

Analyte	Dynamic Range	
	Common Units	SI Units
<b>ALT</b>	5–2000 U/L	5–2000 U/L
<b>Albumin (ALB)</b>	1.0–6.5 g/dL	10–65 g/L
<b>ALP</b>	5–2400 U/L	5–2400 U/L
<b>Amylase (AMY)</b>	5–4000 U/L	5–4000 U/L
<b>AST</b>	5–2000 U/L	5–2000 U/L
<b>Bile Acid (BA)</b>	1–140 mmol/L	1–140 mmol/L
<b>Blood Urea Nitrogen (BUN)</b>	2–180 mg/dL	0.7–64.3 mmol urea/L
<b>Calcium (Ca)</b>	4.0–16.0 mg/dL	1.0–4.0 mmol/L
<b>Chloride (Cl-)</b>	80–135 mmol/L	80–135 mmol/L
<b>Cholesterol (CHOL)</b>	20–520 mg/dL	0.5–13.5 mmol/L
<b>Creatine Kinase (CK)</b>	5–14000 U/L (14K)	5–14000 U/L (14K)
<b>Creatinine (CRE)</b>	0.2–20.0 mg/dL	18–1768 mmol/L
<b>GGT</b>	5–3000 U/L	5–3000 U/L
<b>Globulin (GLOB*)</b>	1–11 g/dL	10–110 g/L
<b>Glucose (GLU)</b>	10–700 mg/dL	0.6–38.9 mmol/L
<b>Magnesium (Mg)</b>	0–8 mg/dL	0–3.29 mmol/L
<b>Phosphorus (PHOS)</b>	0–20 mg/dL	0–6.46 mmol/L
<b>Potassium (K+)</b>	1.5–8.5 mmol/L	1.5–8.5 mmol/L
<b>Sodium (Na+)</b>	110–170 mmol/L	110–170 mmol/L
<b>Thyroxine (T₄)</b>	0.5–8.0 mg/dL	6.5–103 nmol/L
<b>Total Bilirubin (TBIL)</b>	0.1–30.0 mg/dL	1.7–513 mmol/L
<b>Total Carbon Dioxide (tCO₂)</b>	5–40 mmol/L	5–40 mmol/L
<b>Total Protein (TP)</b>	2.0–14.0 g/dL	20–140 g/L
<b>Uric Acid (UA)</b>	0.3–25 mg/dL	18–1488 mmol/L

* Calculated value.

**Table C-3: Correlation of VetScan System with Comparative Method**

Analyte		Canine (n = 22–180)	Feline (n = 20–55)	Equine (n = 7–101)	Bovine (n = 126)
<b>Alanine Aminotransferase (ALT) (U/L)</b>	Correlation (r)	1.00	0.98	0.97	N/A
	Slope	0.95	0.92	0.94	
	Intercept	0	0	6	
	Sample range	10–1549	27–99	11–30	
<b>Albumin (ALB) (g/dL)</b>	Correlation (r)	0.96	0.75	0.89	0.97
	Slope	0.99	1.02	0.99	0.83
	Intercept	0.1	0	-0.6	7
	Sample range	1.3–4.6	2.1–4.8	1.2–3.2	2.4–4.0
<b>Alkaline Phosphatase (ALP) (U/L)</b>	Correlation (r)	1.00	0.97	1.00	0.97
	Slope	0.89	0.81	0.90	0.83
	Intercept	-5	1	-4	7
	Sample range	15–1722	6–54	119–1476	13–136
<b>Amylase (AMY) (U/L)</b>	Correlation (r)	0.96	1.00	N/A	N/A
	Slope	0.67	0.74		
	Intercept	-34	117		
	Sample range	366–1991	473–3474		
<b>Aspartate aminotransferase (AST) (U/L)</b>	Correlation (r)	1.00	1.00	1.00	0.94
	Slope	1.02	1.03	0.94	0.89
	Intercept	1	1	16	-0.58
	Sample range	18–176	18–125	107–1787	68–262
<b>Bile Acids (BA) (μmol/L)</b>	Correlation (r)	1.00	1.00	N/A	N/A
	Slope	0.96	1.09		
	Intercept	1	-1		
	Sample range	0–125	0–137		
<b>Blood Urea Nitrogen (BUN) (mg/dL)</b>	Correlation (r)	1.00	1.00	1.00	0.98
	Slope	0.98	1.07	0.95	0.99
	Intercept	-2	-5	-1	1.4
	Sample range	4–117	14–165	3–64	6–25
<b>Calcium (Ca) (mg/dL)</b>	Correlation (r)	0.84	0.77	0.94	0.89
	Slope	1.24	1.24	1.18	0.78
	Intercept	-1.9	-2.1	-0.8	0.66
	Sample range	7.3–13.0	6.3–12.4	7.2–15.1	5.2–9.8
<b>Chloride (Cl-) (mmol/L)</b>	Correlation (r)	0.935	0.979	N/A	N/A
	Slope	0.875	0.882		
	Intercept	15	12		
	Sample range	78–132	86–123		
<b>Cholesterol (CHOL) (mg/dL)</b>	Correlation (r)	0.99	0.99	N/A	N/A
	Slope	0.99	1.06		
	Intercept	6	-3		
	Sample range	103–450	63–257		
<b>Creatine Kinase (CK) (U/L)</b>	Correlation (r)	N/A	N/A	1.00	0.99
	Slope			0.97	0.95
	Intercept			-2	-36.2
	Sample range			69–14000	79–2047

**Table C-3: Correlation of VetScan System with Comparative Method (Continued)**

Analyte		Canine (n = 22–180)	Feline (n = 20–55)	Equine (n = 7–101)	Bovine (n = 126)
<b>Creatinine (CRE) (mg/dL)</b>	Correlation (r)	0.99	1.00	0.95	N/A
	Slope	1.00	1.01	1.00	
	Intercept	0.0	-0.1	-0.4	
	Sample range	0.6–10.6	0.3–13.6	0.3–6.2	
<b>Gamma glutamyl transferase (GGT) (U/L)</b>	Correlation (r)	1.00	N/A	0.99	0.97
	Slope	0.96		1.11	1.13
	Intercept	2		0	0.67
	Sample range	5–65		5–317	7–54
<b>Glucose (GLU) (mg/dL)</b>	Correlation (r)	0.96	1.00	0.97	N/A
	Slope	1.01	0.97	0.94	
	Intercept	-6	3	16	
	Sample range	28–348	52–607	36–353	
<b>Magnesium (Mg) (mg/dL)</b>	Correlation (r)	N/A	N/A	N/A	0.98
	Slope				1.09
	Intercept				-0.1
	Sample range				1.2–4.2
<b>Phosphorus (PHOS) (mg/dL)</b>	Correlation (r)	0.994	0.916	0.971	0.99
	Slope	1.09	0.80	0.991	1.06
	Intercept	-0.19	0.81	-0.06	-0.5
	Sample range	0.8–87	2.4–6.9	0.8–7.8	1.9–9.7
<b>Potassium (K+) (mmol/L)</b>	Correlation (r)	0.96	0.91	0.84	N/A
	Slope	0.92	0.92	0.97	
	Intercept	0.4	0.5	0.1	
	Sample range	3.2–6.9	2.7–5.3	1.8–4.6	
<b>Sodium (Na+) (mg/dL)</b>	Correlation (r)	0.89	0.86	0.86	N/A
	Slope	0.97	1.08	1.00	
	Intercept	4.8	-12.2	-0.01	
	Sample range	118–183	122–166	110–166	
<b>Thyroxine* (T₄) (µg/dL)</b>	Correlation (r)	0.92	0.86	N/A	N/A
	Slope	1.01	1.49		
	Intercept	-0.1	-0.4		
	Sample range	0.5–8.1	0.5–4.5		
<b>Total Bilirubin (TBIL) (mg/dL)</b>	Correlation (r)	0.87	1.00	1.00	N/A
	Slope	0.84	0.92	0.90	
	Intercept	0.1	-0.3	0.1	
	Sample range	0.1–3.2	0.4–15.0	0.6–26.1	
<b>Total Protein (TP) (g/dL)</b>	Correlation (r)	0.98	0.97	0.99	0.98
	Slope	1.03	0.96	0.97	1
	Intercept	0.1	0.4	0.3	0.47
	Sample range	2.6–10.7	4.8–8.5	3.0–9.5	6–10
<b>Total Carbon Dioxide (tCO₂) (mmol/L)</b>	Correlation (r)	0.81	0.93	0.97	N/A
	Slope	0.86	0.90	0.93	
	Intercept	3.5	2.4	2.1	
	Sample range	6–23	7–31	9–39	

Comparative Method: Hitachi 91

* Comparative Method: RIA

# Species Labels

In addition to Dog, Cat, and Horse, the following species labels are available on the VS2 analyzer:

## ■ Canines

- Coyote
- Dingo
- Fox
- Jackal
- Wolf

## ■ Felines

- Bobcat
- Cheetah
- Jaguar
- Leopard
- Lion
- Lynx
- Panther
- Puma
- Tiger

## ■ Equines

- Donkey
- Pony
- Zebra

## ■ Bovines

- Cow
- Water Buffalo
- Steer
- Ox
- Bull
- Buffalo
- Bison

## ■ Avians

- Bird
- African Gray
- Amazon
- Chicken
- Cockatiel
- Cockatoo
- Conure
- Dove
- Duck
- Flamingo
- Goose

■ **Reptiles/Amphibians**

- |                                    |                                     |                                   |
|------------------------------------|-------------------------------------|-----------------------------------|
| <input type="checkbox"/> Reptile   | <input type="checkbox"/> Lizard     | <input type="checkbox"/> Snake    |
| <input type="checkbox"/> Alligator | <input type="checkbox"/> Monitor    | <input type="checkbox"/> Toad     |
| <input type="checkbox"/> Crocodile | <input type="checkbox"/> Python     | <input type="checkbox"/> Tortoise |
| <input type="checkbox"/> Frog      | <input type="checkbox"/> Salamander | <input type="checkbox"/> Turtle   |

■ **Small Mammals**

- |                                       |                                      |                                   |
|---------------------------------------|--------------------------------------|-----------------------------------|
| <input type="checkbox"/> Small Animal | <input type="checkbox"/> Hamster     | <input type="checkbox"/> Rabbit   |
| <input type="checkbox"/> Bat          | <input type="checkbox"/> Hedgehog    | <input type="checkbox"/> Raccoon  |
| <input type="checkbox"/> Chinchilla   | <input type="checkbox"/> Lemur       | <input type="checkbox"/> Rat      |
| <input type="checkbox"/> Ferret       | <input type="checkbox"/> Mink        | <input type="checkbox"/> Skunk    |
| <input type="checkbox"/> Gerbil       | <input type="checkbox"/> Opossum     | <input type="checkbox"/> Squirrel |
| <input type="checkbox"/> Guinea Pig   | <input type="checkbox"/> Prairie Dog |                                   |

■ **Large Mammals**

- |                                   |                                   |                                   |
|-----------------------------------|-----------------------------------|-----------------------------------|
| <input type="checkbox"/> Antelope | <input type="checkbox"/> Elephant | <input type="checkbox"/> Pig      |
| <input type="checkbox"/> Ape      | <input type="checkbox"/> Giraffe  | <input type="checkbox"/> Sea Lion |
| <input type="checkbox"/> Baboon   | <input type="checkbox"/> Goat     | <input type="checkbox"/> Seal     |
| <input type="checkbox"/> Bear     | <input type="checkbox"/> Kangaroo | <input type="checkbox"/> Sheep    |
| <input type="checkbox"/> Camel    | <input type="checkbox"/> Llama    |                                   |
| <input type="checkbox"/> Deer     | <input type="checkbox"/> Monkey   |                                   |

# Index

## A

---

- Absorbance 9-3
- Advanced Functions 4-4
  - Setting 5-28
- Alert
  - Volume 5-21, 5-22, 5-24

## B

---

- Bar Code Ring 3-8
- Biohazard Symbol 2-2

## C

---

- Calibration 7-1, 9-1, C-6
  - Analyzer 7-1
  - Bar Code 7-1
  - Reagent Rotor 7-1
- Caution Symbol 2-2
- Chemistry Suppression 8-1
- Cleaning 10-1
  - Air Filter 10-2
  - Analyzer 10-1
- Cleaning Spills 10-2
- Communication Drivers
  - Linux 11-13
  - Mac OS X 11-11
  - Windows 11-3
  - Windows Vista 11-7
- Communication Protocol
  - Enabling 11-2
- Computer, Connecting to 11-1
  - ASCII 11-1
  - Baud Rate 11-2
  - Capturing Results 11-16
  - HyperTerminal 11-1, 11-14
  - Parity 11-2
  - Transmission Specifications 11-2

- Controls, Running 7-3
- Correlation C-9
- Cuvettes 3-8

## D

---

- Diluent Container 3-8
- Direct Current Symbol 2-2

## E

---

- Endpoint Reactions 9-4
- Error Messages C-6
- Expected Values C-7

## F

---

- Fasting Patients 4-14
- Foil Pouch 4-5
  - Opening 4-5

## H

---

- HEM 4-14, 6-1
- Hemolysis 4-14, 4-15
- Hemolytic Samples 4-14
- HyperTerminal 11-14

## I

---

- ICT 4-14, 6-1
- Icteric Samples 4-14
- Icterus 4-14
- Identification Numbers 4-7
- Intelligent Quality Control 7-1
- Interfering Substances C-5
- iQC (Intelligent Quality Control) A-1
  - Codes 8-1, A-1
- iQC Flags 6-1

## L

---

- Language
  - Selecting 5-15
- Limitations C-6
- LIP 4-14, 6-1
- Lipemia 4-14
- Lipemic Samples 4-14

## M

---

- Maintenance 10-1
  - Air Filter 10-2
  - Exterior 10-1
  - Spills 10-2

## N

---

- Network Port
  - Symbol 2-2
- Normal Range 4-13, C-6

## O

---

- Operation 9-1
  - Analytes 9-2
  - Chromophores 9-2
  - Cuvette 9-2
  - Endpoint Reactions 9-4
  - Multiple-Wavelength Detector 9-2
  - Rate Methods 9-3
  - Stroboscopic Xenon Lamp 9-2
  - System Errors 9-2
  - Transmittance 9-2
  - Wavelength Selection System 9-2
- Optional Advanced Functions 4-4
  - Setting 5-28
- Optional Materials 12-2
- Ordering Information 1-2, 12-1, 12-2

## P

---

- Patient Identification Numbers 4-7
- Principles of Procedure 9-1
  - Control 9-1
  - Heparinized Whole Blood 9-1
  - Mixing Chamber 9-1
  - Plasma 9-1
  - Serum 9-1

## Q

---

- Quality Control 7-1, C-6
  - During Analysis 7-2

## R

---

- Rate Methods 9-3
- Reagent Rotors 3-7, 4-15, C-2
  - Bar Code Ring 3-8
  - Cuvettes 3-8
  - Diluent Container 3-8
  - Expired 4-15
  - Instability C-4
  - Interfering Substances C-5
  - Methods Performance C-8
  - Sample Fill Line 3-7
  - Storage 4-15, C-4
- Reagent Rotors. See also Testing
- Recall Function
  - Last Rotor Results 6-2
- Reference Ranges
  - Customizing 5-2
  - Printing 5-10
  - Transmitting 5-12
- Required Materials 1-2, 12-1
- Results 4-1, 9-1, C-6
- Returning Analyzer for Service 10-4
- Rotor
  - Handling 4-15
  - Opening and Closing Drawer 3-6
- Rotor Cancellation 8-2
- Rotor Test Panels C-2
- Running Controls 7-3

## S

---

- Sample Fill Line 3-7
- Samples
  - Hemolytic 4-14
  - Icteric 4-14
  - Lipemic 4-14
- Screen Click
  - Volume 5-21, 5-22, 5-24
- Self Test 4-5



Service 10-1, 10-4  
See also Maintenance  
Set Up 3-1  
Software  
Installation 10-3  
Special Function 5-2  
Start Button 3-6

Supplies  
Ordering 1-2, 12-1, 12-2  
Supported Printers A-1, B-1  
Symbols  
Biohazard 2-2  
Caution 2-2  
Direct Current 2-2  
Network Port 2-2  
USB Connection 2-2

## T

---

Test Panels C-2  
Test Parameters C-5  
Test Principles 9-1  
Testing  
Adding Sample to Rotor 4-2, 4-6  
Air Bubble 4-6  
Canceling Analysis 4-12  
Fixed 100  $\mu$ L Volume Pipette 4-3  
Practice Rotor 4-3  
Reagent Rotor Preparation 4-2  
Results 4-13  
Sample Collection 4-2, C-4  
Sample Delivery Volume 4-4, 4-6  
Step-by-Step Procedure 4-5  
Timing Considerations 4-2, 4-15  
Testing Procedure 4-1, C-5  
Limitations C-6  
Materials Required C-2  
Timing Considerations C-6  
Touchscreen 3-6  
Transmission Specifications 11-2  
Transmitting All Error Records 6-9

Troubleshooting 8-1  
Abaxis Technical Support 8-1  
Chemistry Suppression 8-1  
Error Report, Printing 8-2  
Messages 8-1  
Result Messages 8-1  
Rotor Cancels 8-2, 8-3

## U

---

Units  
Common 5-16  
Selecting 5-16  
SI (Systeme International) 5-16  
USB Connections 3-6

## V

---

VetScan VS2 Chemistry Analyzer  
Ambient Operating Temperature 3-5, C-5  
Analyzer Identification 5-13  
Dimensions 3-5  
Display 3-6  
Drawer 3-6  
Intended Use 2-1  
Overview 2-1  
Physical and Environmental Specifications  
3-5  
Power Adapter 3-1, 3-6  
Power Cord 3-1, 3-6  
Power Requirements 3-5  
Quick Reference Guide 3-1  
Results 3-5  
Results. See also Testing  
Returning for Service 10-4  
Start-Up Packet 3-1  
System Description 3-5  
Touchscreen 3-6  
USB Cable 3-1  
USB Connection  
USB Connections 3-6  
Weight 3-5  
Volume  
Setting 5-21, 5-22, 5-24

