

PERI-PRO® III

INTRA-ORAL FILM PROCESSOR



USER'S MANUAL

AIR equipped for life®
TECHNIQUES



CONGRATULATIONS

Thank You and Congratulations on your purchase of the Peri-Pro III Intra-oral Film Processor, manufactured and sold by Air Techniques, Inc. Using a proven roller-less transport system, this unique processor carefully guides up to eight films at once through the developing process without the image surface being touched. Automatically, in just five-minutes, eight films are processed, dried with heated air, and deposited into the film receptacle dry-to-dry and ready to read making it the choice of the dental profession.

The Peri-Pro III uses a heating pad system to maintain uniform chemistry bath temperature ensuring the delivery of consistent film quality. Additional features include:

- No plumbing connection required
- Slim space saving design makes it ideal for small office spaces.
- Easy operation - load eight films for processing in less than one minute
- Automatically processes up to eight films at once in only 5 minutes
- Convenient access door facilitates easy wash water refill
- Optional Daylight Loader or Daylight/Loader Film Duplicator eliminates the need for a dark room

Each Peri-Pro III system has been designed and manufactured to produce the most rugged and dependable film processing system available for the continual demands of the modern dental office. Review and follow the guidelines included in this manual to ensure that your Peri-Pro III gives the highest level of service. By following the Maintenance procedures detailed in this manual, you can depend on years of reliable service from your Peri-Pro III film processor.

TABLE OF CONTENTS

Installation

Key Parts Identification	3
Box Contains / Unpack	4
Install & Assemble Processor	4-5

Operation

Operator Controls	5
Processing film	6-7

Maintenance

Daily	8
Every Two Weeks	8-9
Quarterly	10

Trouble Shooting

Specifications / Dimensions

Accessories

KEY PARTS IDENTIFICATION

Figure 1. Exterior View

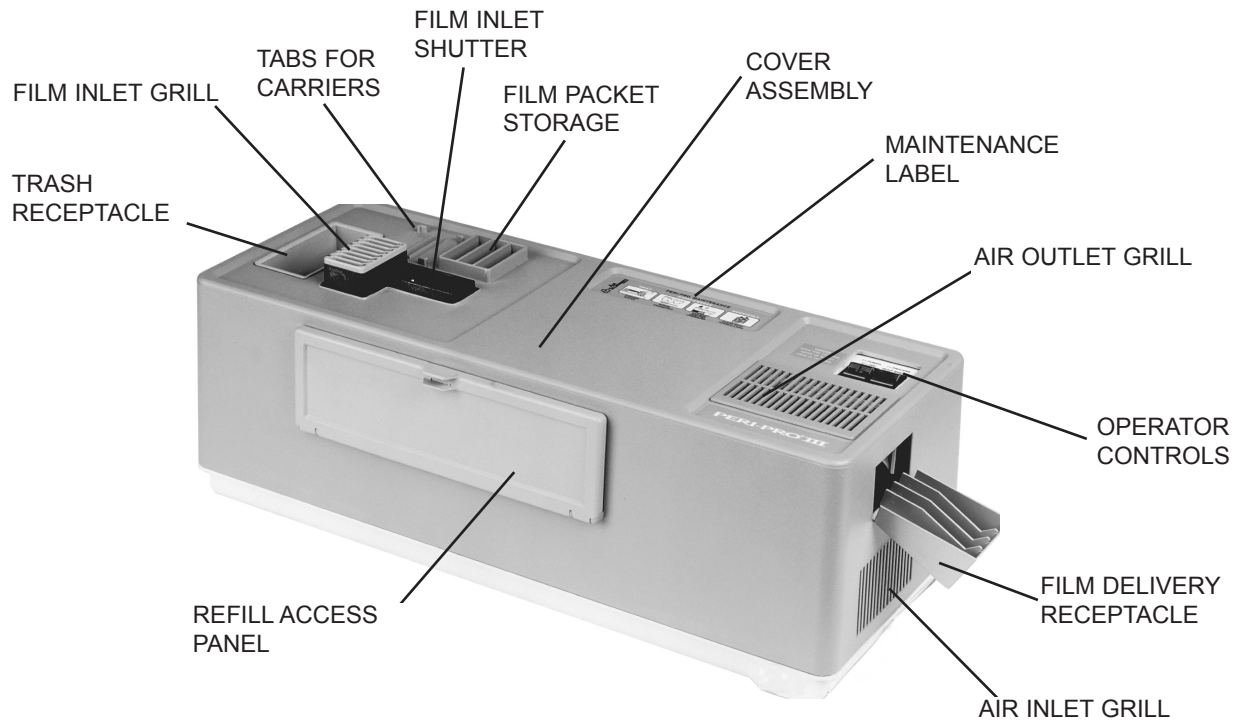

Not shown: Grill inlet cover - comes installed on the Film Inlet Grill

Figure 2. Interior View

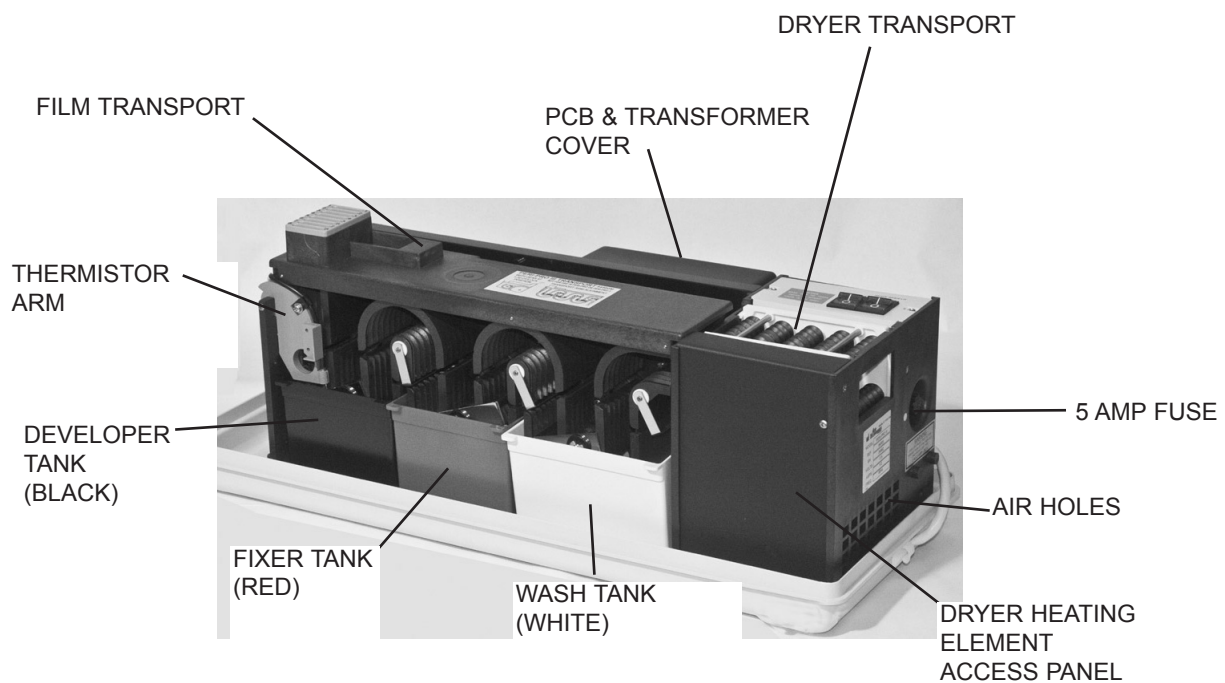

INSTALLATION

Shipping Box Contents:

- ❑ Peri-Pro III Processor base with cover -

Note: Grill Inlet Cover comes installed on the Film Inlet Grill

Inside the processor:

- ❑ Film transport
- ❑ Chemistry tanks (**Black developer tank; red fixer tank; white water tank**)
- ❑ Accessory boxes (3) containing:
 - # 90850** -
 - 3 ea. Pedo (#0) Film Carrier
 - 2 ea. Bite-wing Film (#3) Carrier
 - # 90825** -
 - 3 ea. Anterior Film (#1) Carrier
 - 1 ea. Occlusal Film (#4) Carrier
 - # 90840** -
 - Film receptacle with 3 dividers

Unpack:

1. Place one hand on each side and underneath the processor. Lift the processor out of the carton and place it on a flat surface. Remove the end caps and plastic bag.
2. Remove the processor cover and set aside.
3. Remove the accessory boxes and retain for future use. Remove the top packing foam.
4. Pull the cardboard insert out of the dryer rack and set aside; lift the transport out (the transport cannot be removed until the cardboard insert is removed first).
5. Remove the shipping foam from the back wall of the processor.
6. Remove the foam cleaning pads from the chemistry tanks and set aside.
7. Do not remove the clips holding the water drain tube to the perimeter of the base.
8. Set the base on a flat, level, stable counter.

Important: The surface must be stable so that chemistry does not splash or spill.

Install Processor

1. Fill Tanks

The tanks can be installed in or removed from the base only when the film transport is out of the processor. If you installed the transport after unpacking, remove it now.

Follow the tank installation and chemistry filling sequence below to prevent contamination of chemistry due to accidental spilling or splashing. Fixer in the developer tank will cause contamination.

Important: Peri-Pro chemistry should be at or below 75°F.

- ❑ Locate the thermistor arm above and to the left of the developer (black) tank. Carefully lift the arm up, using the finger hole, until it locks in place. See Figure 3.

Note: Empty entire contents into the water tank.

- ❑ Remove all three tanks and rinse.
- ❑ Install the fixer tank next to the water tank, and fill with contents of the fixer bottle. Pour carefully to prevent splashing.
- ❑ Install the developer tank on the left. Fill with the contents of the developer bottle. Lower the thermistor arm into the tank.
- ❑ If chemistry or water is accidentally spilled beneath the chemistry tanks, remove the tanks and immediately dry the tanks, both sides of the heater plate and the depression in the base and the area around the heater pad. Reverse the procedure to remove.

Figure 3.

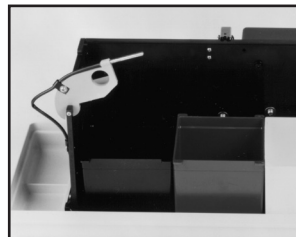

2. Assemble Processor

- ❑ Lower the film transport straight into the tanks. The film transport must sit squarely on the cut-outs found on the top of the vertical plates to the left and right side of the tanks.

Note: The Transport locks the thermistor into place.

- ❑ Install the film inlet grill on top of the film transport. Note that it installs one way: track 1 to the rear and track 8 to the front of the processor.
- ❑ Install the processor cover onto the base with the refill access door in front.
- ❑ Snap the film dividers (optional installation) into place in the film delivery receptacle. Hang the film delivery receptacle on the cutout at the dryer end of the cover.
- ❑ Plug the line cord into a 115V outlet.

Figure 4

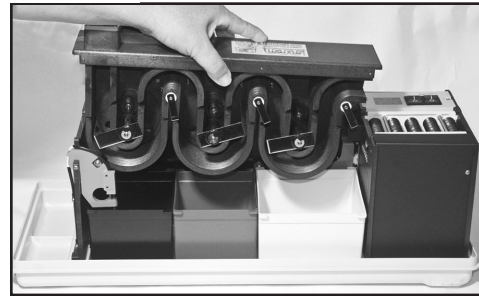

3. Check Operation of Refill Access Door

- ❑ Open the refill access door by firmly pinching the two tabs, then pulling the door open. There will be some resistance.
- ❑ Close the panel by pushing it in until it latches (snaps) shut.

Figure 5



OPERATION

Operating Controls

POWER SWITCH (Amber)

When the POWER switch is turned ON it will illuminate, indicating that there is power to the processor and the heating system is on. Turn the POWER switch OFF at the end of the day. See Figure 6A.

After processing, the PROCESS switch is turned OFF. The Peri-Pro remains ready to process film as long as the POWER switch is left in the ON position and the green READY light is illuminated. See Figure 6B

Figure 6

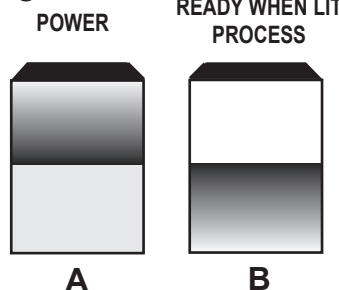

TEMPERATURE READY LIGHT (Green)/PROCESS SWITCH.

When chemistry reaches its factory pre-set processing temperature of 75°F, the READY light flashes, then remains steady, indicating that chemistry is at processing temperature. Processing is initiated by turning the PROCESS switch ON.

REFILL ACCESS DOOR

Open the refill access door when changing and refilling water, and to check chemistry levels at the start of the day.

REFILL ACCESS DOOR

This door must be closed when processing film. It is closed when it latches, or snaps, shut. See Figures 1 and 5.

FILM INLET SHUTTER

When the shutter is slid to the right, it latches in place. Films drop into the transport and begin processing automatically when the transport arms move into position and the shutter opens. New batches of film can be processed every 55 seconds.

Figure 7

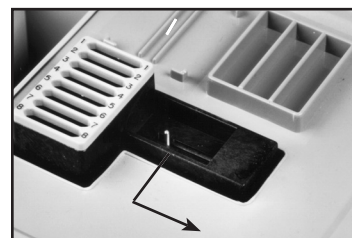

OPERATION

Processing Film

Duplicating films exposed in the Peri-Pro Film Duplicator/Daylight Loader are processed in the same manner as regular films.

1. Before processing film, open the refill access door to determine whether chemistry in the developer and fixer tanks are at the Fill Line level as indicated on the inside of the refill access door. If not, top with water to the Fill Line. Close the refill access door.
2. Turn the **POWER** switch **ON**. The amber light illuminates, indicating that there is power to the processor, the heating system is on and the chemistry is being heated. Chemistry heats at a rate of about 1°F every two to three minutes. For example: chemistry initially at 65°F will reach set point (75°F) in about 25 minutes.
3. When the chemistry is within 1°F of the pre-set processing temperature, the **TEMPERATURE READY/PROCESS** light flickers. When the light remains steady, the factory pre-set temperature has been reached and the Peri-Pro III is ready to process film. Only process film when the **TEMPERATURE READY/PROCESS** light is on.
4. Turn the **PROCESS** switch **ON**. (There is no visual indication, only an audible motor sound and warm air blowing out of the air outlet grill when processor is in the **PROCESS** mode.) Insert film into the film inlet and slide the shutter to the right until it latches. Film is automatically processed. A new batch of film can be processed every 55 seconds.

Use the handy removable trash receptacle when stripping covers off film.
The trash receptacle is especially useful when using a Daylight Loader.

Processing #2 (Adult) Films.

#2 films can be fed directly into the processor

Figure 9

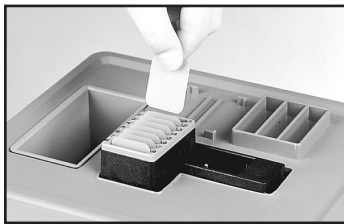

- a. Strip the cover off a periapical film and place it into any of the eight slots of the inlet grill. All 8 slots can be loaded at the same time if required. Do not put two films into the same slot.
- b. Slide the shutter to the right until it latches. The films drop into the transport and begin processing when the transport arms automatically move into position and the shutter opens.

Note: If a film is bent, straighten it.

- c. As soon as the shutter moves back into the original closed position, the next batch of films may be loaded into the inlet slots and the process repeated.
- d. When the last films to be processed are loaded, place the inlet cover over the film inlet. The inlet cover prevents film fogging due to light leaks. If a Daylight Loader is being used, put the inlet cover in place before hands are removed from the cuffs.

Note: The inlet cover comes installed on the grill inlet.

- e. When films have completed the processing cycle, they are delivered into the film delivery receptacle.

Note: With dividers in place in the film receptacle, the four compartments correspond to slots 1 & 2, 3 & 4, 5 & 6, 7 & 8 of the film inlet grill. The dividers separate sets of film pairs.

❑ **Processing #0 (Pedo) or #1 (Adult Anterior) Films.**

#0 and #1 films cannot be fed directly into the processor. These films fit into corresponding # carriers (supplied with the processor), each of which carries the film through the processing cycle. Up to six #0 or #1 films can be loaded into corresponding carriers at one time.

- a. To load #0 or #1 film into the corresponding # carrier, nest the carrier inside the tabs on the cover, next to the inlet grill.
- b. Strip the cover off the film(s) and slide the film(s) vertically, one at a time, into any of the six grooves on the carrier. Push down firmly until the film touches the cover. Repeat until as many grooves as required are filled. The films should be standing vertically and parallel to each other, away from the center bar. Make sure that each film on the carrier is in its own groove.
- c. Remove the film inlet grill. (Remember to replace it when processing #2 films.) Insert the carrier, with the film(s) standing vertically, into the film inlet.
- d. Slide the shutter to the right until it latches. The carrier will drop into the transport and begin processing when the shutter automatically opens.

Figure 10

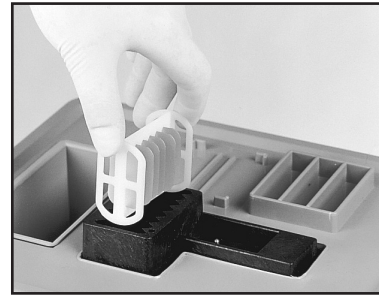

❑ **Processing #3 (Bite-Wing) Films**

#3 films cannot be fed directly into the processor. Use a #3 carrier that holds two films at a time.

- a. Strip the cover off one or two #3 film(s) and slide the film(s) horizontally, one at a time, through both side plates of the #3 carrier. Remove film inlet grill.
- b. Insert the carrier into slots 3 and 6 in the film inlet. Make sure the edges of the film(s) clear the side walls of the film inlet.
- c. Slide the shutter to the right until it latches. The carrier will drop into the transport and processing begins when the shutter automatically opens.

Figure 11

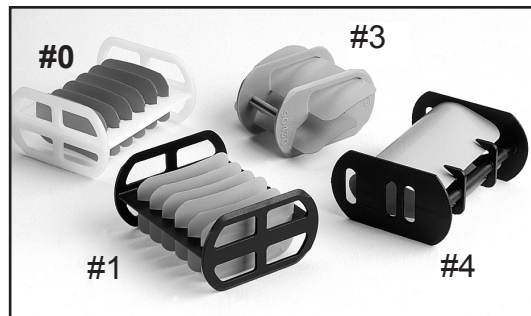

❑ **Processing #4 (Occlusal) Films**

- a. Strip the cover off one #4 film and carefully bend almost in half. Slide the film into the carrier, making sure both edges of the film are held in place by the guide tabs. Remove film inlet grill.
 - b. Place the carrier onto the film inlet with the orientation arrow (on the side of the carrier) pointing down.
 - c. Slide the shutter to the right until it latches. The carrier will drop into the transport and begin processing when the shutter automatically opens.
5. When processing is completed, turn the **PROCESS** switch **OFF**. The green **READY** light remains lit. At the end of the day turn the **POWER** switch **OFF**. Both the green **READY** light and the amber **POWER** light will extinguish.

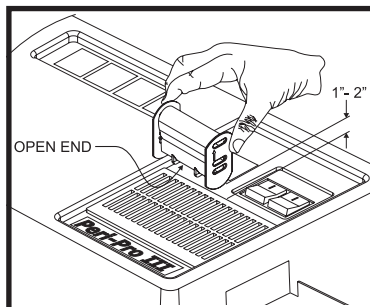

To assure complete drying of processed # 4 films, a manual assist may be needed, if so;

1. While the fan is blowing, hold the open end of the film in the carrier directly over the dryer grille, about 1"- 2" elevation is sufficient, and slowly pivot the carrier to have warm air blow on the outer surface.
2. 30-60 seconds should be enough time to adequately dry film.
3. Unload the dried film from the carrier when done.

MAINTENANCE

Servicing your Peri-Pro III on a daily, two week and quarterly basis is critical to maintaining quality processor performance. We recommend the maintenance procedure outlined below, using Formula 2000 Plus cleaner, and Peri-Pro Developer and Fixer, which are specially formulated for Peri-Pro processors. This maintenance schedule may have to be modified if more frequent cleaning is required.

DAILY - CHANGE WATER TOP OFF CHEMISTRY TANKS WITH WATER TO FILL LINE

Important:

Make sure not to mix the developer and fixer chemistry. Contaminating the solution will degrade image quality.

Dispose of wash water in accordance with local codes.

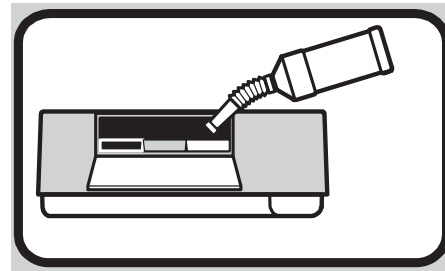

1. Turn **POWER OFF** and unplug the power cord from the outlet.
2. Remove the film delivery receptacle (see figure 1) at the film dryer exit on the right side of the cover. Remove the main cover by carefully lifting away from the unit.

Important: Do not splash chemistry or contamination may result.

3. As shown by Figure 4, carefully lift the Film Transport and hold over the tanks for a few seconds so liquids drain back into tanks and place the transport on the service tray P/N 90121.
4. Remove the water tank (white), discard the water and rinse out the tank. If the wash tank is particularly soiled or slimy, it must be thoroughly cleaned and rinsed.
5. Refill the clean water tank with 70° 80°F water; reinsert into base.
6. Check that the solution in the developer (black) and fixer (red) tanks are up to the Fill Lines as indicated on the inside of the refill access door. If not, top off the developer and fixer tanks with water.
7. Slowly and carefully lower the Film Transport straight into the tanks. The Film Transport must sit squarely on the cutouts found on the top of the vertical plates to the left and right side of the tanks.
8. Align the Main cover and carefully install the Main Cover onto the unit.
9. Hang the film delivery receptacle (see figure 1) on the film dryer exit on the right side of the cover.
10. Plug the power cord into the electrical outlet and turn the **POWER ON**.

EVERY TWO WEEKS (or every 300 - 350 films) SCRUB TRANSPORT; CHANGE PERI-PRO CHEMISTRY

Caution: Cleaning and changing chemistry requires the removal of the cover and film transport from the Peri-Pro III. Always turn **POWER off** and unplug the line cord before removing the cover or transport.

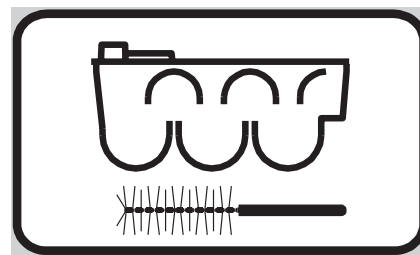

Scrub Transport

1. Turn **POWER OFF** and unplug the line cord. Remove the film receptacle, lift off the cover.
2. Lift the film transport and let the solutions drip back into the tanks before placing the transport in a sink. (Use of optional Service Tray PN 90121 will contain any dripping chemistry.)
3. Rinse the transport thoroughly with warm water to soften residue and dried chemistry. Be sure to rinse above the chemistry level, keeping the shutter and the film inlet on the top of the transport dry. (Use a sink or the transport wash tub that comes with the Transport Cleaning Kit PN 43975.)

4. Scrub grooves inside the transport with a small brush, paying close attention to the areas just above the chemistry line, where crystallization occurs. Rinse to remove deposits. See Figure 12.
5. Scrub and rinse the gears on the back of the transport.
6. With a dry, lint-free cloth wipe off any moisture from the shutter and the film inlet area and grill. Important: These areas must be dry before processing film.
7. Clean the dryer transport rollers if dry, white chemistry residue is evident. Follow the procedure detailed under Quarterly Maintenance #12.

Figure 12



CHANGE PERI-PRO CHEMISTRY

Change Developer and Fixer every two weeks or every 300 - 350 films, whichever comes first.

Caution: Never operate the Peri-Pro III without liquid in the tanks.

1. Change the water. Follow the steps for changing water under Daily Maintenance.
 - If the wash tank is particularly soiled or slimy, it must be thoroughly cleaned and rinsed. To do this, first remove the film transport.
 - If the tank was removed, clean and dry the tank drain stem receptacle in the base.
 - Clean and drain the drip pan.
 - After cleaning, reinstall the wash tank.
2. Carefully lift the thermistor arm up until it locks in place (and remove the transport if it is still installed). Remove the developer and fixer tanks and dispose of the old chemistry in accordance with local codes. Clean the thermistor.
3. Rinse and, using separate color-coded sponges to avoid possible contamination, clean both tanks. Rinse again and wipe dry with a lint-free towel.
4. Reinstall the fixer (red) tank in the base. Fill with contents of the Peri-Pro fixer bottle. Pour carefully to prevent splashing.
5. Reinstall the developer (black) tank in the base. Fill with contents of the Peri-Pro developer bottle. Pour carefully to prevent splashing and possible contamination. Lower the thermistor arm into place in the developer tank.

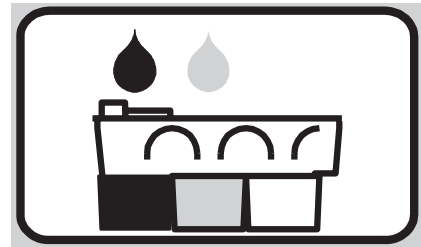

Note: Peri- Pro chemistry should be at or below 75°F.

Reassemble the Peri-Pro III

1. Slowly and carefully lower the film transport straight into the tanks. The film transport must sit squarely on the cutouts found on the top of the vertical plates to the left and right side of the tanks.
2. Insert the film inlet grill on top of the transport.
3. Install the cover with the refill access door in front. Hang the film delivery receptacle on the cutout at the dryer end of the cover.
4. Plug the line cord into a 115V outlet and turn the **POWER** switch **ON**.

MAINTENANCE

QUARTERLY - CLEAN WITH FORMULA 2000 Plus

Clean the Peri-Pro III Transport with Formula 2000 Plus quarterly or whenever a black residue is evident on the transport or in the tanks.



Use the Peri-Pro Transport Cleaning Kit (PN 43975)

Each kit contains:

- Cleaning tub
- Brush and cleaning sponges
- Twin pack of Formula 2000 Plus

CAUTION: Use in a well ventilated area. Wear protective clothing, rubber gloves and goggles. Review the Material Safety Data Sheet that comes with every Formula 2000 Plus Twin Pack.

1. Turn the **POWER OFF** and unplug the line cord. Remove the film receptacle; lift the cover off.
2. Remove the transport and rinse under running water.
3. Place the transport into the cleaning tub with the gears facing up ↑ .
4. Pour two bottles of Formula 2000 Plus Component 1 into the cleaning tub. Pour slowly. Do not splash or splatter solution - wipe up any spills. (Use both bottles of Formula 2000 Plus in the Twin Pack to insure adequate cleaning of the transport.)
5. Add cold water to the recessed line in the tub.

Figure 13



CAUTION: Use cold water only.

6. Sprinkle two powder packets of Component 2 evenly across the cleaning tub. Formula 2000 Plus's effervescent cleaning action will begin as soon as Component 2 is added. Some odor and vapor will be evident.
7. Soak the transport for approximately 30 minutes, or until the effervescent action stops.
8. Remove the transport and, under cold running water, remove any remaining deposits with the brush; rinse.
9. Dispose of the cleaning solution in accordance with local codes. Rinse the cleaning tub and place the transport back in the tub. Fill with fresh water and drain. Rinse and drain at least 2 more times. (Be sure to rinse thoroughly since cleaner residue can contaminate fresh chemistry.)
10. Place the transport on a towel with the gears facing up and air dry thoroughly. Check that the shutter area is dry before using. If not, dry with a soft, lint-free towel. See Fig. 14.
11. Change the water. Follow the steps for changing water under Daily Maintenance. If the wash tank is particularly soiled or slimy, it must be thoroughly cleaned and rinsed. After cleaning, if the tank was removed.
12. Clean the Dryer Transport if dry, white chemistry residue is evident on the rollers.
 - Remove the screw holding the dryer front cover plate in place.
 - Slide the cover plate up, remove it and lift the dryer transport straight up and out.
 - Use warm water and a brush to remove the residue; rinse and completely air dry.
 - Reinstall the dryer transport and the cover plate.

Figure 14

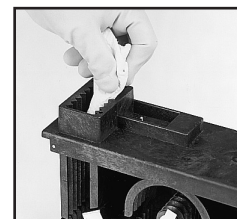

Important: This plate is necessary for proper film drying.

13. Change the chemistry. Follow the steps for changing chemistry under Every Two Weeks Maintenance.
14. Reinstall the transport and reassemble the Peri-Pro III. Follow the steps for reassembly under Every Two Weeks Maintenance.

TROUBLESHOOTING

Problem	Possible Cause	Possible Solutions
1. Film too light.	<ul style="list-style-type: none"> a. Developer exhausted. b. Chemistry does not reach factory set temperature. c. X-ray machine is improperly set or inconsistent. d. Developer is contaminated e. Improper or outdated film. f. Not using specially formulated Peri-Pro chemistry. 	<ul style="list-style-type: none"> a. Change chemistry after 300-350 film or 2 weeks, whichever comes first. b. Call you authorized Air Techniques dealer for service. c. Call your x-ray dealer for service d. Dispose of chemistry and clean with Formula 2000 Plus. Replace chemistry and water. e. Check date on film box f. Use Peri-Pro chemistry to assure film quality and archival quality
2. Film too dark or grainy too high	<ul style="list-style-type: none"> a. Developer temperature is b. X-ray machine is improperly set or inconsistent. c. Film has been exposed to light d. Not using specially formulated Peri-Pro chemistry. 	<ul style="list-style-type: none"> a. Call you authorized Air Techniques dealer for service. b. Call your x-ray dealer for service c. Check for and correct light leaks in the dark room or daylight loader. Place the inlet cover on the film inlet before leaving the darkroom or before removing hands from the daylight loader cuffs. d. Use Peri-Pro chemistry to assure film quality and archival quality
3. Film is cloudy or has brownish surface.	<ul style="list-style-type: none"> a. Fixer is exhausted. b. Fixer temperature is too low. c. Chemistry does not reach factory set temperature. d. Improper or outdated film. 	<ul style="list-style-type: none"> a. Change chemistry after 300-350 film or 2 weeks, whichever comes first. b. Wait until the ready light stays on continuously, indicating that the set-point has been reached. c. Call you authorized Air Techniques dealer for service. d. Check date on film box. Make sure that the film being used is recommended for automatic processing.
4. Film is not dry.	<ul style="list-style-type: none"> a. Improper or outdated film. b. Depleted chemistry. c. Contaminated chemistry. d. Not using specially formulated Peri-Pro chemistry. e. Defective dryer heater, fan motor or thermal fuse. (If air is not hot, heater or fuse is defective.) f. Dryer air shroud or baffles are not in place. 	<ul style="list-style-type: none"> a. Check date on film box. Make sure that the film being used is recommended for automatic processing. b. Change chemistry after 300-350 film or 2 weeks, whichever comes first. c. Dispose of chemistry, clean with Formula 2000 Plus. Replace chemistry and water. d. Use Peri-Pro chemistry to assure film quality and archival quality. e. Call your authorized Air Techniques dealer for service. f. Call your authorized Air Techniques dealer for service.

TROUBLESHOOTING

Problem	Possible Cause	Possible Solutions
5. Film has black edge at one end.	a. Light fog.	<p>a. Check for and correct light leaks in the dark room or daylight loader. Put the grill inlet cover on the film inlet before leaving the dark room or before removing hands from the daylight loader cuffs.</p> <p>b. Safe light defective or too close. Light should be a minimum of 4 feet away from the work area.</p>
6. Film has a diagonal or curved line through it.	<p>a. Chemistry level is low. The entire film is not being covered by chemistry bath as it travels down into the chemistry tanks.</p> <p>b. Chemistry deposits and crystallization are clogging the grooves in the transport, preventing the films from fully dropping into the chemistry bath.</p> <p>c. Timing of the transport arms is out of adjustment.</p>	<p>a. Make sure chemistry is at the Fill Line. If not, top off tank to the Fill Line with water.</p> <p>b. Clean grooves with a soft toothbrush.</p> <p>c. Call your authorized Air Techniques dealer for service.</p>
7. Developer is black, has ammonia smell, there are black deposits on the bottom of the tank, black streaks or smudges on film, poor film density, poor film clarity.	a. Contaminated developer.	a. Tanks and transport must be cleaned with Formula 2000 Plus. Change chemistry.
8. Images or shadows of other films appear on the developed film. Light is striking films that were stripped and stacked on each other before being loaded into the film inlet.	<p>a. Safe light in the darkroom is defective or less than 4 feet from film inlet.</p> <p>b. Light is leaking into the dark room.</p> <p>Unit with Daylight Loader:</p> <p>c. 1. Too much light is passing through the view glass.</p> <p>c. 2. Light may be leaking around the daylight loader cuffs.</p>	<p>a. Correct as required.</p> <p>b. Correct as required.</p> <p>c.1. View glass test: Cover the view glass, then process film.</p> <p>c.2. Loader cuffs: Inspect for worn or damaged cuffs, replace.</p>

Problem	Possible Cause	Possible Solutions
9. Film not exiting.	<ul style="list-style-type: none"> a. Chemistry deposits in transport grooves cause film to pop out. b. Severely bent or jagged film. c. Film has jagged edge (burr) in solution d. Films fed incorrectly. e. Transport arms are out of alignment. Films will be lost constantly, not occasionally. f. Defective drive motor. g. Films reach dryer and staythere - broken gear teeth or defective gears or install missing ones. 	<ul style="list-style-type: none"> a. Clean grooves with a soft toothbrush. b. Straighten film before loading. Insert with rough or burred end facing up. c. Proper cleaning of grooves overcomes this. Use film without jagged edge. d. Make sure transport is seated squarely. Put only one film into a track. Use film inlet grill for #2 film. When using a film carrier, load the carrier so that the film does not hit the side of the inlet. e. Call your authorized Air Techniques dealer for service. f. Call your authorized Air Techniques dealer for service. g. Call your authorized Air Techniques dealer for service to replace missing gear in gear train.
10. Shutter does not catch, sticks or is hard to move.	<ul style="list-style-type: none"> a. Broken spring, worn release bar, defective shutter, shutter is off tracks, or shutter is contaminated with chemistry. 	<ul style="list-style-type: none"> a. Call your authorized Air Techniques dealer for service.
11. Processor doesn't operate.	<ul style="list-style-type: none"> a. Line cord is not plugged in. b. Defective interior fuse or switch. 	<ul style="list-style-type: none"> a. Plug in line cord. b. Call your authorized Air Techniques dealer for service.
12. Chemistry does not heat or chemistry gets too hot. Otherwise, the Peri-Pro is functioning.	<ul style="list-style-type: none"> a. Defective thermistor, defective PC board or defective heater pad, etc. 	<ul style="list-style-type: none"> a. Call your authorized Air Techniques dealer for service.

DIMENSIONS/SPECIFICATIONS

DIMENSIONS:

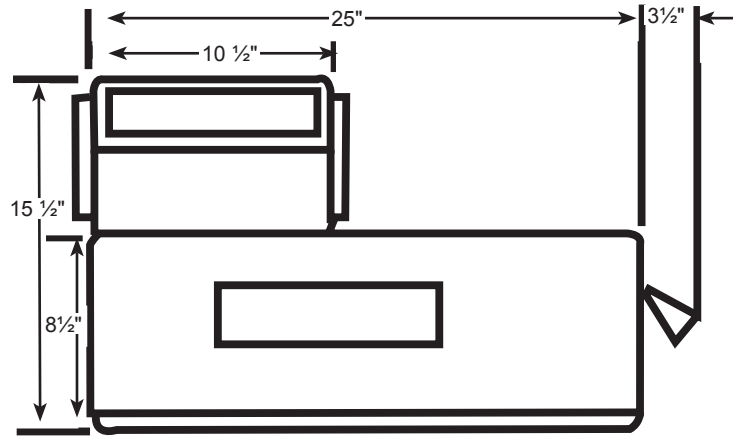

	Length	Width	Height
Overall	25"	9 3/4"	8 1/2"
With Daylight Loader	25"	9 3/4"	15 3/4"
With Film Duplicator/Daylight Loader	25"	12 3/4"	15 3/4"
Add 3 1/2" to length for film receptacle			

MINIMUM CLEARANCE TO REMOVE COVER:

Without Daylight Loader - 14 1/2"

With Daylight Loader or Film Duplicator/Daylight Loader - 21 3/4"

SPECIFICATIONS:

TANK CAPACITIES

Developer and Fixer Tanks - 32 oz. each
Water Tank - 40 oz.



ELECTRICAL REQUIREMENTS

115 Volts, 5 Amps

WEIGHT

28 lbs. (kg)

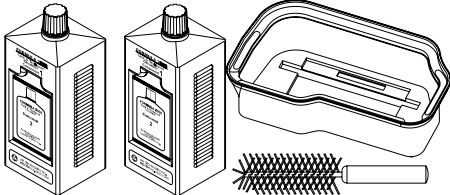
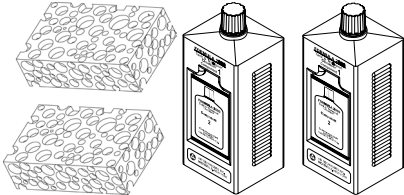
ACCESSORIES/OPTIONS

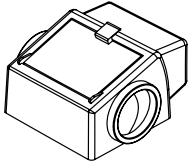
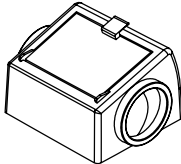
Description	Part Number
<p>Peri-Pro Transport Cleaning Kit This kit contains all items needed to chemically clean a Peri-Pro Transport: 1 - cleaning tub 1 - brush 1 - twin pack of Formula 2000 Plus</p>	<p>43975</p> 
<p>Refill for Transport Cleaning Kit Formula 2000 Plus Twin Pack Contains 2 bottles of Formula 2000 Plus 2 color-coded sponges</p>	<p>43945</p> 
<p>Peri-Pro Chemistry Case contains: 3 one qt. bottles Developer 3 one qt. bottles Fixer</p>	<p>90800</p> 
<p>Film Carriers Pedo (#0) - Box of 5 Adult Anterior (#1) - Box of 5 Bite-Wing (#3) - Box of 5 Occlusal (#4) - Box of 3</p>	<p>90980 90985 90990 90831</p>
<p>Film Duplicator / Daylight Loader</p>	<p>92000</p> 
<p>Daylight Loader</p>	<p>90090</p> 
<p>Service Tray</p>	<p>90121</p>

For over 50 years, Air Techniques has been a leading innovator and manufacturer of dental products. Our priority is ensuring complete satisfaction by manufacturing reliable products and providing excellent customer and technical support. Whether the need is digital imaging, utility room equipment or merchandise, Air Techniques can provide the solution via our network of authorized professional dealers. Proudly designed, tested and manufactured in the U.S., our products are helping dental professionals take their practices to the next level.

Air Techniques' family of quality products for the dental professional include:

- Digital Imaging**
 - Digital Radiography
 - Intraoral Camera
 - Caries Detection Aid
 - Intraoral X-ray
 - Film Processors

- Utility Room**
 - Dry Vacuums
 - Wet Vacuums
 - Air Compressors
 - Amalgam Separator
 - Utility Accessories
 - Utility Packages

- Merchandise**
 - Evacuation System Cleaner
 - Imaging Accessories
 - Chemistry
 - Processor Accessories

Corporate Headquarters

1295 Walt Whitman Road | Melville, New York 11747- 3062
Phone: 800-247-8324 | Fax: 888-247-8481

www.airtechniques.com

