

MIDMARK®

Installation and Operation Manual

M7 SpeedClave Steam Sterilizer



Safety
4

Introduction
5

Installation
6

Components
8

Operation
10

Maintenance
15

Calling for
Service
16

Limited
Warranty
17

Owner's Product Identification

Information that you'll need to provide for servicing

Serial Number

Model Number

Date of Purchase

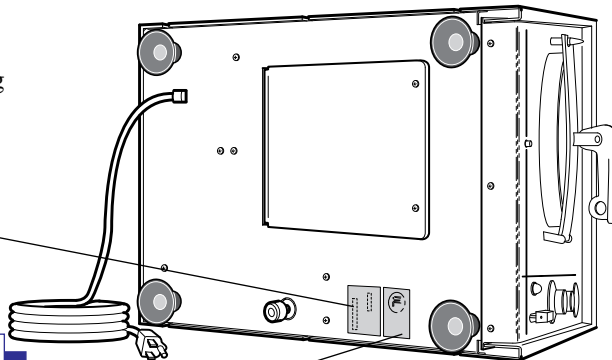

Name of Owner/Facility/Department

Name of Authorized Dealer

Telephone # of Authorized Dealer

Address of Authorized Dealer

Contents

SAFETY	4
Explanation of Safety Symbols and Notes	4
INTRODUCTION	5
Scope and Purpose	5
General Information	5
General	5
INSTALLATION	6
Electrical Service Requirements	6
Specifications	6
Locating Sterilizer	7
COMPONENTS	8
OPERATION	10
General Operation Information	10
Preparation Before Operation	10
Loading	10
Cleaning Instruments	12
Loading Trays	12
Monitoring Loads	12
Sterilizing	12
Termination of Cycle before Completion	14
MAINTENANCE	15
CALLING FOR SERVICE	16
LIMITED WARRANTY	17

SAFETY

To assure safer and more reliable operation, read this manual before operating your equipment; assure that appropriate personnel are informed on the contents of this manual—this is the responsibility of the purchaser; be sure that you understand the instructions contained in this manual before attempting to operate this equipment; and keep this manual permanently affixed to this equipment.

Explanation of Safety Symbols and Notes



DANGER

Indicates an imminently hazardous situation which, if not avoided, will result in death or serious injury. This signal word is limited to the most extreme situations.



WARNING

Indicates a potentially hazardous situation which, if not avoided, could result in death or serious injury.



CAUTION

Indicates a potentially hazardous situation which, if not avoided, may result in minor or moderate injury. It may also be used to alert against unsafe practices.



EQUIPMENT ALERT

Indicates an imminently or potentially hazardous situation which, if not avoided, will or may result in serious, moderate, or minor equipment damage or cause malfunction.

NOTE

Note is used to amplify an operating procedure, practice, or condition.

INTRODUCTION

Safety

Introduction

Scope and Purpose

This manual covers instructions for the operation of Ritter's M7 SpeedClave® Steam Sterilizer and is intended to be used by any medical personnel responsible for operating this equipment or performing operator level maintenance.

General Information

Designed for use in physician's offices, clinics, hospitals, nursing homes, and laboratories, the Ritter M7 SpeedClave® Steam Sterilizer sterilizes wrapped and unwrapped instruments, linen packs, and glassware. Additionally, we recommend that you use sterility monitors to ensure sterility.



DANGER

Do not use the sterilizer for processing liquids or volatile substances and materials which could cause toxic and explosive conditions that would cause personal injury.

Distilled or demineralized water for sterilization is contained in the condensing tank and is released when the FILL/VENT lever is pressed. The water flows through piping to the chamber until the chamber is filled to within 1/2" (13 mm) of the front rim. After the chamber has been loaded and the door closed and locked, the unit is ready for sterilizing. A temperature regulator controls the heat and a timer controls the duration of the cycle. After sterilization has been completed, the steam is exhausted from the chamber by pressing down on the FILL/VENT lever, allowing the steam to return to the condensing tank.

INSTALLATION

Place the sterilizer on a level surface to assure proper water flow.

Electrical Requirements

Refer to the serial number label located on the underside of the sterilizer and connect the three prong electrical supply cord to the appropriate electrical supply.

Specifications

Dimensions

Overall length 18.125" (46.04 cm)

Overall width 13.56" (34.45 cm)

Overall height 12.81" (32.5 cm)

Counter area 16 1/2" x 14" (410 mm x 345 mm)

Chamber 7 1/2" x 15" (19.0 cm diameter x 38.1 mm deep)

Chamber Safety Valve set at 31 PSI (214 kPa)

Trays

Large (2) 12" x 5.625" x 0.875" (30.5 cm x 14.3 cm x 2.22 cm)

Small (1) 12" x 4.125" x 0.875" (30.5 cm x 10.5 cm x 2.22 cm)

Weight

Empty 32 lb (14.5 kg)

Operating 33 lb (15.1 kg)

Electrical

50 Hz Model 230 Volts, 5 Amp, single phase

60 Hz Model 115 Volts, 10 Amp, single phase

Heater Element 1150 Watts

Heater Insulation ... 20 Megaohms or better

Locating Sterilizer

The sterilizer must be placed on a level surface to ensure proper gravity filling of water in the chamber. If the sterilizer is going to be operated under the unusual condition of heavy duty continuous cycles, locate the sterilizer where excessive emission of steam will not damage materials and equipment in the surrounding area.

Allowing sufficient time between cycles for cooling the unit or refilling the reservoir with water (as outlined in step one of the operating instructions) minimizes the emission of steam from the water reservoir fill area.

**DANGER****EQUIPMENT ALERT**

Do not use this sterilizer in areas where explosive anesthetics are stored.

- A. **Table Top Height:** 31" (760 mm) to 37" (920 mm) above the floor.
- B. **Table Top Surface:** Formica, stainless steel or stone. Material to resist spilled water, steam blow-off, discoloration of paint, etc. Heat from bottom of sterilizer will produce about 160°F (71°C) temperature on the surface of the table for short periods of time.
- C. **Back Ventilation:** Allow about 22" (540 mm) of counter depth which gives 2 1/2" (60 mm) of space behind the sterilizer for air circulation when there is a wall behind the sterilizer.
- D. **Distance to Side Walls:** The sides of the sterilizer should be a minimum of 2 1/2" (60 mm) from walls, equipment, or other obstructions that might inhibit side air ventilation of the unit.
- E. **Distance Above Sterilizer:** Wall cabinets or shelves should be no less than 25" (600 mm) above the counter to provide space for filling the reservoir with water and cooling processed trays.

COMPONENTS

1. **Sterilizer Door** - The self-aligning door pivots on a crossarm, hinged to the body. The crossarm is spring loaded. Pressure applied by the handle securely closes the door. The door is opened by releasing handle pressure.
2. **Door Handle** - Swing the door handle to the left to open the door, then push handle to the right against spring tension. Swing door out and to the right to open. Reverse procedure to close the door.
 - 2.1 **Door handle in "latched" position.**
 - 2.2 **Door handle in "vent" position.**
 - 2.3 **Door handle in "unlatched" position.**
3. **Temperature Gauge** - Indicates temperature in the chamber. The dial is graduated from 170 to 270°F (77 to 132°C).
4. **Temperature Regulator** - Controls the operating temperature in the chamber. A dial stop prevents setting temperature higher than 270°F (132°C).
5. **Cycle Timer** - Controls the time that the load will be exposed to steam at set temperature. The timer is graduated in minutes from 0 to 30 and functions as the ON/OFF switch.
6. **FILL/VENT Lever** - Admits water to the chamber and vents water and steam from the chamber.
7. **Pilot Light (red)** - Indicates when the heater is on.
8. **Reset Button** - Restores operation after low-water thermostat has tripped to prevent overheating of the chamber.
9. **Fill Opening** - Located on the top of the cover and is covered with a plastic cap and gasket.
10. **Full Indicator** - Located inside the condensing tank and can be seen through the fill opening.
11. **Petcock** - Drains the unit and is accessible from the bottom of the unit.
12. **Trays** - The sterilizer comes with three corrosion resistant perforated metal trays.
13. **Tray Rack** - The sterilizer comes with a tray rack.
14. **Power Supply Cord** - Has a three prong plug for connecting sterilizer to a receptacle providing 120V, 10 AMP, 60 Hz or 230V or 5 AMP, 50 Hz service with equipment grounding contact. Serial number label on sterilizer specifies proper voltage.
15. **Chamber.**
16. **Condensing Tank.**

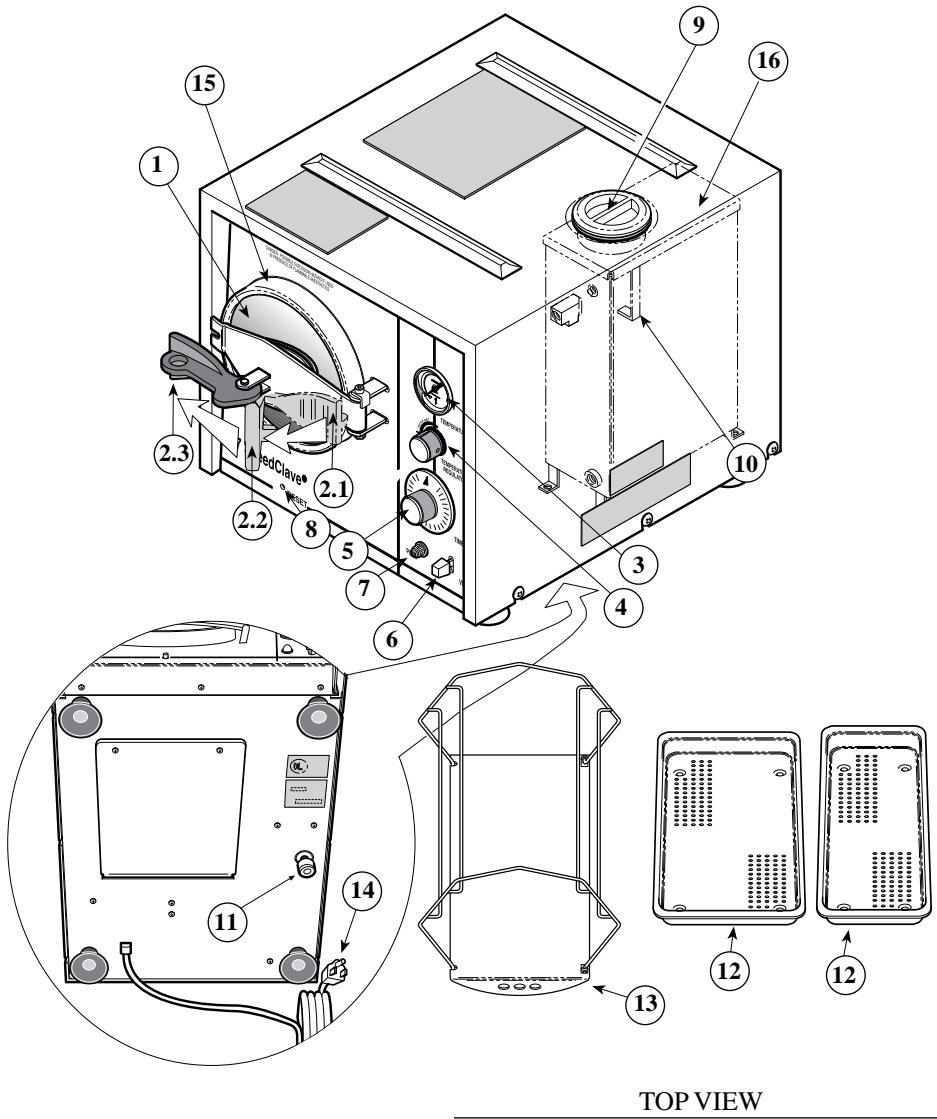

Components

OPERATION

General Operation Information

- Detailed sterilizer operating instructions are furnished with each sterilizer. Abbreviated instructions are printed on a decal on top of the unit.
- Trays can be placed on the rails on top of the sterilizer for cooling.
- To open door, swing door handle to the left and then push door slightly to the right against spring tension. Swing door out and to the right (reverse procedure for closing).
- During the sterilizing cycle, the pilot light blinks ON and OFF when the heater is in operation. If the pilot light does not glow, be certain the timer is in the ON position. Also, check the electrical power supply line and the thermostat reset.
- The sterilizer is protected by an automatic low-water control. This safety control prevents the sterilizer from operating with no water in the chamber. To return unit to operating condition, add water and press reset button.

Operation

Preparation Before Operation

1. Check the water reservoir daily. Fill the water reservoir with distilled or demineralized water to the FULL mark in the reservoir.
2. Adjust the temperature regulator during INITIAL OPERATION as follows:
 - a. For 270°F (132°C), turn temperature regulator knob fully counterclockwise. This will give a maximum temperature of approximately 270°F (132°C).
 - b. For 250°F (121°C), turn temperature regulator knob fully counterclockwise and watch the temperature gauge. When 250°C is attained, turn temperature regulator knob slowly to the right (clockwise) until pilot light goes out. Mark the 250°F (121°C) setting on the white band surrounding the temperature regulator knob for future reference.

Loading



WARNING

Do not use this equipment for sterilizing liquids or volatile substances. Also, do not use this equipment for any purpose other than sterilizing. Failure to heed this warning could cause toxic explosions which could cause serious personal injury or death.

Suggested Times and Temperatures

Load	°F	°C	Minutes
*Unwrapped instruments, glassware	270	132	3
Wrapped instruments	270	132	15
Dressings, bandages, sutures	250	121	30
Syringes (disassembled), needles	250	121	30
Rubber goods and gloves	250	121	20
* instruments for immediate use			

Operation

Effects of Altitude on Sterilization

The M7 Sterilizer utilizes a mechanical pressure relief valve that is set to be fully open at 31 PSI (214kPa). The pressure relief valve opens when the pressure differential between the inside of the pressure vessel and atmosphere is 31 PSI (214 kPa). The pressure of saturated steam at 270°F (132°C) is 28 PSI (193 kPa). The sterilizer creates a saturated steam environment to efficiently sterilize items. Sterilizer operation can be affected by reductions in atmospheric pressure. At elevations up to a few 1000 feet, this is not a factor. As the altitude above sea level increases, the pressure relief valve is exposed to a greater differential pressure because the pressure inside the chamber is the same and the pressure outside the chamber has decreased.

If the pressure relief valve begins to open prematurely when utilizing 270°F (132°C) sterilization, it is recommended that a reduced sterilization temperature and longer exposure time be utilized. The following exposure times and temperatures then can apply as prescribed in the book "Principles and Methods of Sterilization in Health Sciences" by John J. Perkins.

Load	°F	°C	Minimum Exposure Time (in minutes)
Unwrapped instruments, glassware	250	121	15
Wrapped instruments	250	121	20

NOTE: Exposure time is the total time required for sterilization of the load. This period begins when the sterilizer reaches the sterilization temperature. The temperature must then be held for the times recommended above. Heat up and cool down times are not to be included.

Cleaning Instruments

With clean hands and/or while wearing clean surgical gloves, clean instruments thoroughly and dry before you place instruments in the sterilizer.



EQUIPMENT ALERT

Incomplete and improper cleaning of instruments will impede sterilization and may cause damage to instruments and/or sterilizer.

Loading Trays

Joined instruments must be sterilized in an open position. Place all containers so that they will drain. Do not wrap instruments too tightly. Inadequate sterilization may result from improper wrapping. Do not stack trays on top of one another. At least one inch should separate trays.

Do not pack sterilizer chamber excessively or overload tray. Provide adequate space between instruments and packs for proper steam circulation and drying. Overloading may cause a sterilization failure.

Do not plug syringes or needles. Disassemble syringes if possible. Place absorbent paper or linen towel in bottom of tray. When using sterilization pouches, set pouches on their sides to maximize steam circulation and to facilitate drying.

Monitoring Loads

Include an internal process indicator strip with each sterilizer load to verify gross heat penetration. A biological spore test indicator should be used weekly in a representative sterilizer load for sterilization assurance. Sterilization indicators/monitors should be placed in the front bottom area of the sterilizer or the most difficult to sterilize location.

For wrapped or packed instruments, place indicators/monitors inside with instruments.

Check with local, state or national health care regulations and guidelines regarding the frequency of testing.

Sterilizing

1. Check water reservoir. Fill tank to FULL indicator daily.



EQUIPMENT ALERT

Use only distilled or demineralized water to prevent collection of mineral deposits in operating components. Do not overfill. Excess water spillage could result in a malfunction of the electrical components.

2. With the door open, press down on FILL/VENT lever. Water will flow into the chamber. Hold lever down until water level is within 1/2" of the front rim.
3. Load the sterilizer and lock door.
4. Set timer for 15 minutes to heat water in the chamber.
5. When pilot light goes out and gauge indicates sterilizing temperature, reset timer for required sterilizing time.
6. Automatic timer will shut off heater and buzzer will sound when cycle is complete.
7. Turn timer knob counterclockwise to zero to turn off buzzer.
8. Pull door handle to vent position (see illustration on page 9).

NOTE

For maximum drying of sterilized articles, the unit must be vented immediately after sterilization cycle is complete.

9. Vent the sterilizing chamber. With the door handle in the vent position, hold the FILL/VENT lever down until the door pops inward and steam escapes. Release the FILL/VENT lever when door pops inward.

NOTE

The M7 will make a loud gurgling sound while venting.

10. Allow 15 minutes for drying the instruments after the door has popped inward.



CAUTION

Do not turn on heat or open the door during the 15 minute drying period.

11. Open door-unload. For your convenience, a tray rack is located on top of the sterilizer.

Termination of Cycle before Completion

The red pilot light will be out and the temperature will drop when the cycle is terminated before normal completion of the cycle.

Usual Causes for Termination

- * Low water in the chamber.
- * The door is opened during a cycle.
- * Proper temperature is not maintained.
- * The circuit breaker trips.

Corrective Action

1. Swing door handle to vent position (see illustration on page 9) and wait 15 minutes for steam to dissipate.



WARNING

Sterility of the load can not be assured when the cycle has terminated before completion.

2. Remove load.
3. Check water reservoir and fill if required.
4. Check water level in chamber, if low fill to within 1/2" of the front rim.
5. Close door and press reset button.

If the test cycle completes without a malfunction, continue with regular load sterilization using new monitors and indicators.

If test cycle malfunctions, rotate timer counterclockwise to zero, the OFF position. Unplug power cord. Do not open the door. Do not attempt any further corrective action on the sterilizer.

Contact the nearest authorized service facility for examination, repair or adjustment of the sterilizer.



WARNING

Any attempt by untrained personnel to take further corrective action could create a hazard to persons in the area and also result in unsterile processed goods.

MAINTENANCE

It is the responsibility of the user to establish a periodic maintenance procedure to assure correct operation of the equipment and reliable sterilization of the loads. Contact your Midmark Medical products local distributor or representative to develop a program for planned maintenance.

DAILY



WARNING

Prior to and while performing cleaning procedure, unit and water drained from reservoir and piping system may be hot. Use caution to prevent burns. Tray rack and chamber interior will also be hot. Allow to cool to room temperature before wiping clean.

External Surfaces

Wipe with a soft dry cloth and wash occasionally with a damp cloth and mild soap or detergent.

Door Gasket

Clean door gasket and mating surface with a damp cloth. Examine for possible damage that would prevent a good sealing surface.

WEEKLY

Chamber

The sterilizing chamber should be cleaned weekly. First, drain the water from the reservoir. A petcock is located at the bottom of the unit to facilitate draining. Wash the inside of the chamber with mild soap and distilled or demineralized water. **DO NOT USE ABRASIVES OR BLEACHING AGENTS IN THE CHAMBER** (ie. steel wool, scouring powder, bleach, etc.). Rinse with distilled or demineralized water. Fill the reservoir with distilled or demineralized water.

MONTHLY

System Flushing

To protect the intricate parts of the unit, the system must be flushed once a month with Speed Clean Sterilizer Cleaner.

1. Mix thoroughly four ounces of Speed-Clean with two quarts (approximately 2000 cc.) of distilled water.
2. Drain reservoir and fill with cleaning solution.

3. Run one 30-minute cycle at 250°F. Instruments should not be sterilized while cleaning sterilizer.
4. Drain cleaning solution from chamber and reservoir. Fill reservoir with clean distilled water and run two 30-minute cycles at 250°F.
5. Drain reservoir and allow sterilizer to cool to room temperature. Remove tray rack. On the M7, this is accomplished by unhooking, then rotating the left side of the deflection plate to an upright position, then squeezing the bottom of the wire rack together while removing it from the chamber. Wipe out inside of chamber being careful not to damage the heating element. Wipe off tray rack and replace in chamber.
6. Refill the reservoir with clean distilled or demineralized water.
7. Sterilizer is ready for use.

QUARTERLY

Door Gasket

Every three months, remove the door gasket from the channel and clean the channel according to the door gasket cleaning instructions mentioned in this section. A small brush will aid the procedure. Clean and inspect the gasket for damage. Replace the gasket if necessary. Press the gasket into the channel and run one sterilizing cycle to seat the gasket.

Calling for
Service

CALLING FOR SERVICE

If you are having a problem or have a question, refer to the "Owner Product Identification" page of this manual and call your dealer. If you can't resolve your question or problem with your dealer call the following number:

1-800-Midmark (1-800-643-6275);

8:00 AM until 5:00 PM

(Eastern time in the U.S.);

Monday thru Friday, except for standard U.S. holidays.

LIMITED WARRANTY

SCOPE OF WARRANTY

Midmark Corporation (“Midmark”) warrants to the original purchaser its new Alternate Care products and components (except for components not warranted under “Exclusions”) manufactured by Midmark to be free from defects in material and workmanship under normal use and service. Midmark’s obligation under this warranty is limited to the repair or replacement, at Midmark’s option, of the parts or the products the defects of which are reported to Midmark within the applicable warranty period and which, upon examination by Midmark, prove to be defective.

APPLICABLE WARRANTY PERIOD

The applicable warranty period, measured from the date of delivery to the original user, shall be one (1) year for all warranted products and components.

EXCLUSIONS

This warranty does not cover and Midmark shall not be liable for the following: (1) repairs and replacements because of misuse, abuse, negligence, alteration, accident, freight damage, or tampering; (2) products which are not installed, used, and properly cleaned as required in the Midmark “Installation” and or “Installation / Operation Manual for this applicable product. (3) products considered to be of a consumable nature; (4) accessories or parts not manufactured by Midmark; (5) charges by anyone for adjustments, repairs, replacement parts, installation, or other work performed upon or in connection with such products which is not expressly authorized in writing in advance by Midmark.

EXCLUSIVE REMEDY

Midmark’s only obligation under this warranty is the repair or replacement of defective parts. Midmark shall not be liable for any direct, special, indirect, incidental, exemplary, or consequential damages or delay, including, but not limited to, damages for loss of profits or loss of use.

NO AUTHORIZATION

No person or firm is authorized to create for Midmark any other obligation or liability in connection with the products.

THIS WARRANTY IS MIDMARK’S ONLY WARRANTY AND IS IN LIEU OF ALL OTHER WARRANTIES, EXPRESS OR IMPLIED. MIDMARK MAKES NO IMPLIED WARRANTIES OF ANY KIND INCLUDING ANY WARRANTIES OF MERCHANTABILITY OR FITNESS FOR ANY PARTICULAR PURPOSE. THIS WARRANTY IS LIMITED TO THE REPAIR OR REPLACEMENT OF DEFECTIVE PARTS.

SF-1487 REV. A1

Calling for
Service

Limited
Warranty

Notes

Notes

**RETURN TO TABLE
OF CONTENTS**

MIDMARK®

Midmark Corporation, Versailles, Ohio 45380 U.S.A.
937-526-3662 TELEX 288007 FAX 937-526-5542

© Midmark Corporation - 1996

003-0653-00 Rev. G